





Audio

Radio	5-4
Antenna	5-4
FM reception	5-5
AM/FM stereo radio with cassette player (if equipped)	5-5
RADIO OPERATION (for radio with weather band)	5-5
Weather band (WB)	5-6
Power switch and volume control (ON·VOL)	5-6
Fader and balance control (FADER and BAL)	5-7
Bass and treble control (BASS and TREB)	5-7
Band selection switch (BAND)	5-8
Stereo indicator	5-8
Manual tuning (TUNE)	5-8
Automatic tuning (SCAN)	5-9
Selecting preset stations	5-9
How to preset stations	5-9
RADIO OPERATION (for radio without weather band)	5-10
Power switch and volume control (ON·VOL)	5-10
Fader and balance control (FADER and BAL)	5-11
Bass and treble control (BASS and TREB)	5-11
FM/AM selection switch (FM·AM)	5-12
Stereo indicator	5-12
Manual tuning (TUNE)	5-12
Automatic tuning (SCAN)	5-12
Selecting preset stations	5-13
How to preset stations	5-13
CASSETTE PLAYER OPERATION	5-14
Cassette slot	5-14
Tape travel indicators	5-14
Program switching button (PROG)	5-15
Fast-forward button (FF)	5-15
Rewind button (REW)	5-15
Stop and eject button (STOP/EJ)	5-15
Tape program sensor button (TPS)	5-15
Repeat button (RPT)	5-16
Dolby NR button ()	5-16
Auto metal sensor	5-16
Metal tape indicator (MTL) (if equipped)	5-16
CLOCK FUNCTION	5-16
When turning on the radio	5-17
Setting the time	5-17

AM/FM stereo radio with cassette player (if equipped)	5-18
RADIO OPERATION	5-18
Power switch and volume control (SW/VOL)	5-19
Tone and balance control (TONE/BAL)	5-19
FM/AM selection button (FM AM)	5-22
Stereo indicator	5-22
Manual tuning (TUNE)	5-22
Automatic tuning (SCAN)	5-22
Selecting preset stations	5-23
How to preset stations	5-23
CASSETTE PLAYER OPERATION	5-24
Cassette slot	5-24
Tape travel indicators	5-24
Program switching buttons (PROG)	5-25
Fast-forward button (FF)	5-25
Rewind button (REW)	5-25
Stop and eject button (EJECT)	5-25
Dolby NR button ()	5-25
CLOCK FUNCTION	5-26
When turning on the radio	5-26
Setting the time	5-26
AM/FM/WB stereo radio with cassette and compact disc player (if equipped)	5-27
RADIO OPERATION	5-27
Power switch and volume control (PWR/VOL)	5-28
Tone control (AUDIO)	5-28
Fader and balance control (FAD/BAL)	5-30
FM/AM selection button (AM/FM)	5-32
Stereo indicator	5-32
Weather band button (WB)	5-32
Manual tuning (TUNE)	5-32
Automatic tuning (SCAN)	5-33
Selecting preset stations	5-33
How to preset stations	5-33
CASSETTE PLAYER OPERATION	5-34
To play back a cassette tape	5-35
Tape travel indicators	5-35
Program switching button (PROG)	5-35
Fast-forward button (FF)	5-35
Rewind button (REW)	5-36
Stop and eject button ()	5-36
Tape program sensor button (TPS)	5-36
Repeat button (RPT)	5-36
Dolby NR button ()	5-37
Auto metal sensor	5-37
Metal tape button (MTL)	5-37
COMPACT DISC PLAYER OPERATION	5-38

<i>To play back a compact disc</i>	5-38
<i>To select a song from its beginning</i>	5-39
<i>Fast forwarding and fast reverse</i>	5-39
<i>Repeat playback</i>	5-40
<i>Random playback</i>	5-40
<i>Scan</i>	5-40
<i>To eject a disc from the player</i>	5-40
<i>Precautions to observe when handling a compact disc (CD)</i> ...	5-40
CD CHANGER CONTROL	
<i>(If optional CD changer is connected)</i>	5-42
<i>To start playback</i>	5-43
<i>To select the desired disc</i>	5-43
<i>To select a song from its beginning</i>	5-43
<i>Fast forwarding and fast reverse</i>	5-44
<i>Repeat playback</i>	5-44
<i>Random playback</i>	5-44
<i>Scan</i>	5-44
CLOCK FUNCTION	5-45
<i>Display mode</i>	5-45
<i>Setting the time</i>	5-46
Installation of accessories	5-46

Radio

■ Antenna

▼ Pillar mounted antenna

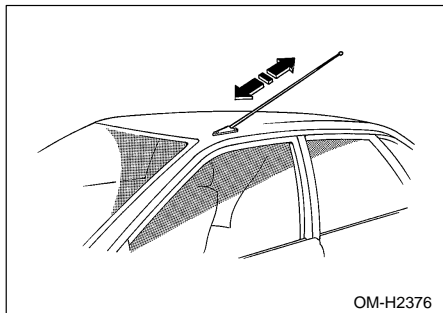

Pull the antenna out to extend it to its full length.

▼ Power antenna



CAUTION

Before tuning on the radio, make sure there are no persons near the antenna since personal injury could result if someone is struck by the antenna during its extension.

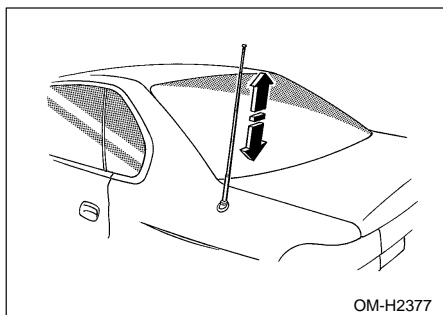

The power antenna automatically extends or retracts when the radio is turned on or off.

■ FM reception

Although FM is normally static free, reception can be affected by the surrounding area, atmospheric conditions, station strength and transmitter distance. Buildings or other obstructions may cause momentary static, flutter or station interference. If reception continues to be unsatisfactory, switch to a stronger station.

AM/FM stereo radio with cassette player (if equipped)

The radio will operate only when the ignition switch is in the "ACC" or "ON" positions.

RADIO OPERATION (for radio with weather band)

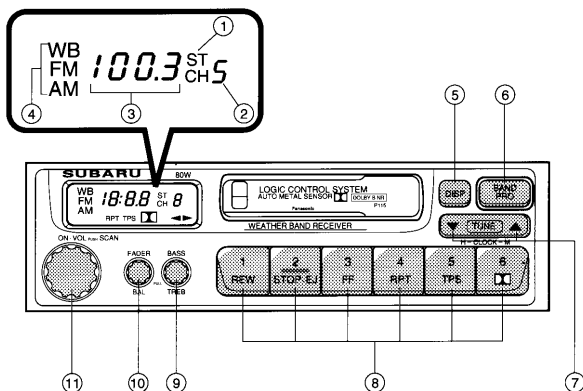

HB0065

- | | |
|-------------------------|--|
| ① Stereo indicator | ⑧ Preset button |
| ② Preset station number | ⑨ Bass and treble control knob |
| ③ Frequency | ⑩ Fader and balance control knob |
| ④ Band | ⑪ Power switch, volume control and SCAN button |
| ⑤ DISP button | |
| ⑥ Band selection switch | |
| ⑦ Tuning button | |

- CONTINUED -

■ Weather band (WB)

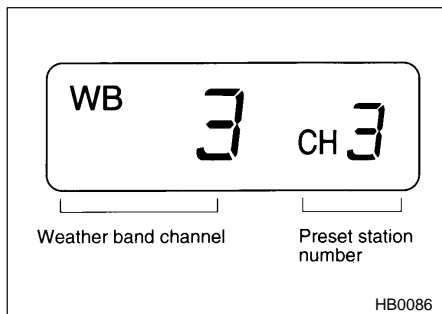

The radio can receive following seven stations of weather band (WB).

WB channel	Station
WB1 :	162.550 MHz
WB2 :	162.400 MHz
WB3 :	162.475 MHz
WB4 :	162.425 MHz
WB5 :	162.450 MHz
WB6 :	162.500 MHz
WB7 :	162.525 MHz

■ Power switch and volume control (ON · VOL)

The same knob is used for both power (on/off) and volume control. The radio is turned on and off by turning the knob clockwise or counterclockwise and the volume is controlled by turning the knob.

■ Fader and balance control (FADER and BAL)

The same knob is used for both fader control and balance control.

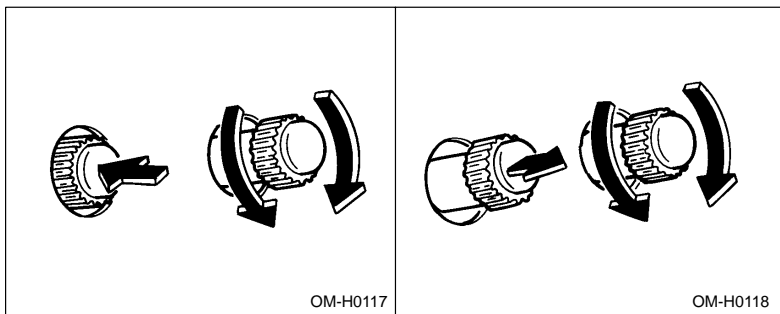

▼ Fader

The fader control adjusts the balance between the front and rear speakers.

Push the knob once to make it pop out. The balance is adjusted by turning the knob from left to right in this condition. A click while turning the knob indicates the center position. After making the desired adjustment, push the knob in again to store the setting.

▼ Balance

The balance control adjusts the balance between the left and right speakers.

Push the knob once to make it pop out, then pull the knob out until it stops. The balance is adjusted by turning the knob from left to right in this condition. A click while turning the knob indicates the center position. After adjusting the balance, push the knob in again to store the setting.

■ Bass and treble control (BASS and TREB)

Bass and treble control is done on same knob. Use that knob for the separate adjustment of low pitch and high pitch sounds.

▼ Bass

The bass control adjusts the level of low pitch sounds.

Push the knob once to make it pop out. The bass is adjusted by turning the knob from left to right in this condition. A click while turning the

– CONTINUED –

knob indicates the center position. After adjusting the bass, push the knob in again to store the setting.

▼ **Treble**

The treble control adjusts the level of high pitch sounds.

Push the knob once and it will pop out, then pull the knob out until it stops. The treble is adjusted by turning the knob from left to right in this condition. A click while turning the knob indicates the center position. After adjusting the treble, push the knob in again to store the setting.

■ **Band selection switch (BAND)**

Push the band selection switch to select either FM, AM or Weather Band (WB) reception. Each time this button is pressed, the band will change in the following order.

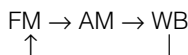

The display indicates which is currently selected.

■ **Stereo indicator**

The stereo indicator “ST” will come on when an FM stereo broadcast is received.

■ **Manual tuning (TUNE)**

▼ **Manual tuning for FM and AM**

Press the tuning button marked “▲” to increase the tuning frequency and press the tuning button marked “▼” to decrease it. Each time the button is pressed, the frequency changes 10 KHz in the AM mode and 0.2 MHz in the FM mode. Constant pressure on the button causes a continuous change in the frequency.

▼ **Manual tuning for WB**

When WB mode is selected, press the tuning button marked “▲” to change the WB channel up and press the tuning button marked “▼” to change the WB channel down. Each time the button is pressed, the WB channel changes next channel. Constant pressure on the button causes a continuous change in the frequency.

■ Automatic tuning (SCAN)

Press the volume control knob to change the radio to the SCAN mode. In this mode, the radio scans through the radio band until a station is found. The radio will stop at the station for five seconds while displaying the frequency, after which scanning will continue until the entire band has been scanned from the low end to the high end. Press the volume control knob again to cancel the SCAN mode and to stop on any displayed frequency.

■ Selecting preset stations

Presetting a station with a preset button allows you to select that station in a single operation. Up to six AM, FM and WB stations each may be preset.

■ How to preset stations

1. Press the band selection switch to select either FM, AM or WB reception.
2. Press the volume control knob or tune the radio manually until the desired station frequency is displayed.
3. Press one of the preset buttons for at least two seconds to store the frequency. The frequency of the station will flash once on the display at this time. If the button is pressed for less than two seconds, the preceding selection will remain in memory.

When the volume control knob is pressed for automatic tuning, stations are scanned in the direction of low frequencies to high frequencies only. Automatic tuning may not function properly if the station reception is weakened by distance from the station or proximity to tall buildings and hills.

NOTE

If the connection between the radio and battery is broken for any reason such as vehicle maintenance or radio removal, all stations stored in the preset buttons are cleared. If this occurs, it is necessary to reset the preset buttons.

RADIO OPERATION (for radio without weather band)

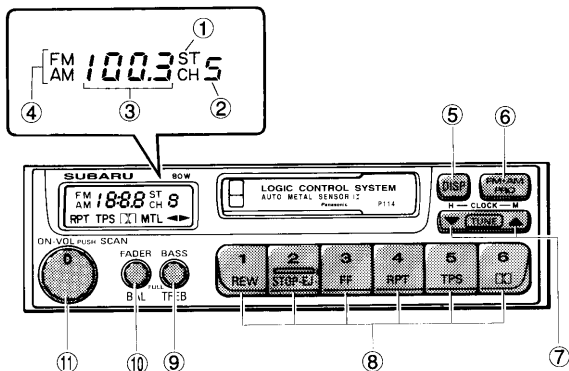

OM-H2432

- | | |
|--------------------------|--|
| ① Stereo indicator | ⑧ Preset button |
| ② Preset station number | ⑨ Bass and treble control knob |
| ③ Frequency | ⑩ Fader and balance control knob |
| ④ Band | ⑪ Power switch, volume control and SCAN button |
| ⑤ DISP button | |
| ⑥ FM/AM selection switch | |
| ⑦ Tuning button | |

■ Power switch and volume control (ON · VOL)

The same knob is used for both power (on/off) and volume control. The radio is turned on and off by turning the knob clockwise or counterclockwise and the volume is controlled by turning the knob.

■ Fader and balance control (FADER and BAL)

The same knob is used for both fader control and balance control.

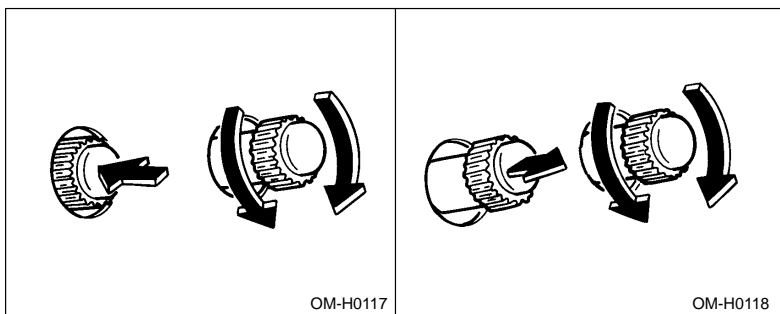

▼ Fader

The fader control adjusts the balance between the front and rear speakers.

Push the knob once to make it pop out. The balance is adjusted by turning the knob from left to right in this condition. A click while turning the knob indicates the center position. After making the desired adjustment, push the knob in again to store the setting.

▼ Balance

The balance control adjusts the balance between the left and right speakers.

Push the knob once to make it pop out, then pull the knob out until it stops. The balance is adjusted by turning the knob from left to right in this condition. A click while turning the knob indicates the center position. After adjusting the balance, push the knob in again to store the setting.

■ Bass and treble control (BASS and TREB)

Bass and treble control is done on same knob. Use that knob for the separate adjustment of low pitch and high pitch sounds.

▼ Bass

The bass control adjusts the level of low pitch sounds.

Push the knob once to make it pop out. The bass is adjusted by turning the knob from left to right in this condition. A click while turning the knob indicates the center position. After adjusting the bass, push the knob in again to store the setting.

▼ Treble

The treble control adjusts the level of high pitch sounds.

Push the knob once and it will pop out, then pull the knob out until it stops. The treble is adjusted by turning the knob from left to right in this condition. A click while turning the knob indicates the center position. After adjusting the treble, push the knob in again to store the setting.

■ FM/AM selection switch (FM · AM)

Use this switch to select either FM or AM reception. The display indicates which is currently selected.

■ Stereo indicator

The stereo indicator “ST” will come on when an FM stereo broadcast is received.

■ Manual tuning (TUNE)

Press the tuning button marked “▲” to increase the tuning frequency and press the tuning button marked “▼” to decrease it. Each time the button is pressed, the frequency changes 10 KHz in the AM mode and 0.2 MHz in the FM mode. Constant pressure on the button causes a continuous change in the frequency.

■ Automatic tuning (SCAN)

Press the volume control knob to change the radio to the SCAN mode. In this mode, the radio scans through the radio band until a station is found. The radio will stop at the station for five seconds while displaying the frequency, after which scanning will continue until the entire band has been scanned from the low end to the high end. Press the volume

control knob again to cancel the SCAN mode and to stop on any displayed frequency.

■ **Selecting preset stations**

Presetting a station with a preset button allows you to select that station in a single operation. Up to six AM and FM stations each may be preset.

■ **How to preset stations**

1. Press the FM/AM selection switch to select either FM or AM reception.
2. Press the volume control knob or tune the radio manually until the desired station frequency is displayed.
3. Press one of the preset buttons for at least two seconds to store the frequency. The frequency of the station will flash once on the display at this time. If the button is pressed for less than two seconds, the preceding selection will remain in memory.

When the volume control knob is pressed for automatic tuning, stations are scanned in the direction of low frequencies to high frequencies only. Automatic tuning may not function properly if the station reception is weakened by distance from the station or proximity to tall buildings and hills.

NOTE

If the connection between the radio and battery is broken for any reason such as vehicle maintenance or radio removal, all stations stored in the preset buttons are cleared. If this occurs, it is necessary to reset the preset buttons.

CASSETTE PLAYER OPERATION

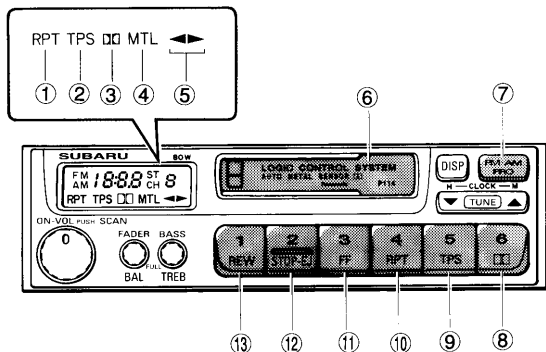

OM-H2433

- | | |
|---|------------------------------|
| ① Repeat indicator | ⑦ Program switching button |
| ② TPS indicator | ⑧ Dolby NR button |
| ③ Dolby NR indicator | ⑨ Tape program sensor button |
| ④ Metal tape indicator
(if equipped) | ⑩ Repeat button |
| ⑤ Tape travel indicator | ⑪ Fast forward button |
| ⑥ Cassette slot | ⑫ Stop and eject button |
| | ⑬ Rewind button |

■ Cassette slot

When a cassette is partially inserted, it is automatically drawn in and starts tape playback.

■ Tape travel indicators

These indicate the direction the cassette tape is moving.

▶ indicates that the top side of the cassette is being played back.

◀ indicates that the bottom side of the cassette is being played back.

■ **Program switching button (PROG)**

When the program switching button is pressed during playback, the tape travel indicators will switch and the player will begin playing back the opposite side of the tape. The same mechanism is automatically activated when the end of the tape is reached. This allows the opposite side of the tape to play, providing continuous playback.

■ **Fast-forward button (FF)**

To fast-forward the tape, press the “FF” button. To stop fast-forwarding, press the “STOP/EJ” button.

■ **Rewind button (REW)**

To rewind the tape, press the “REW” button. To stop rewinding, press the “STOP/EJ” button.

■ **Stop and eject button (STOP/EJ)**

When the “STOP/EJ” button is pressed, playback stops and the cassette tape is ejected.

The ejection function also operates when the ignition switch is turned off. Always make certain that you remove the cassette tape.

■ **Tape program sensor button (TPS)**

Press the “TPS” button during playback to return to the beginning of the current selection or to skip to the beginning of the next selection. To use this function, press the “TPS” button to turn on the “TPS” indicator. If the fast-forward button (FF) is then pressed, the player advances the tape to the beginning of the next selection and starts playing it. If the rewind button (REW) is pressed instead, the player rewinds the tape to the beginning of the current selection and starts replaying it. The “TPS” function may not operate properly under the following conditions:

- When the recording level is low.
- When there are long pauses in the middle of a selection.
- When the tape contains verbal material such as conversations.
- When the blanks between selections are shorter than five seconds.
- When there are no blanks between selections (live concerts, etc.).

■ Repeat button (RPT)

Push the “RPT” button to repeat the piece of music being listened to. To use this function, push the “RPT” button while the piece you want to hear again is being played. “RPT” will be indicated on the display. When the selection ends, the cassette player automatically rewinds to the beginning of the piece and the selection begins again. To cancel the repeat function, push the “RPT” button again. Until the repeat function is cancelled, the same piece of music will be repeated indefinitely. The “RPT” function may not operate properly under the following conditions:

- When the recording level is low.
- When there are long pauses in the middle of a selection.
- When the tape contains verbal material such as conversations.
- When the blanks between selections are shorter than five seconds.
- When there are no blanks between selections (live concerts, etc).

■ Dolby NR button (□□)

Press the “□□” button when playing tapes recorded using the Dolby NR system*. The “□□” indicator will light up and high-frequency noise on the tape will be reduced for clearer sound reproduction.

* Noise reduction system manufactured under license from Dolby Laboratories Licensing Corporation. “Dolby” and double-D Symbol are trade marks of Dolby Laboratories Licensing Corporation.

■ Auto metal sensor

The cassette player automatically adjusts for metal or CrO₂ tape.

■ Metal tape indicator (MTL) (if equipped)

If metal or CrO₂ tape has been inserted into the cassette slot, “MTL” will be indicated on the display.

CLOCK FUNCTION

The radio has a built-in clock function that displays the time when the ignition switch is turned either to “ACC” or “ON”.

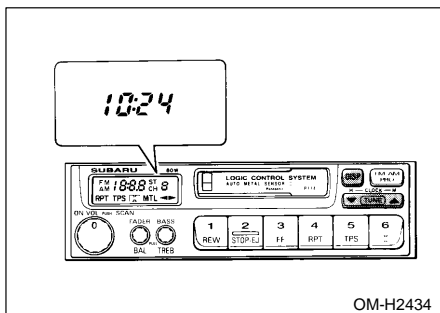

■ When turning on the radio

When the radio is switched on or the station is changed, the time display is replaced by the frequency display. However, after the frequency has been displayed for five seconds, it is replaced by the time display again.

If you wish to see the time while the frequency is being displayed, press the “DISP” button and the frequency display will be replaced with the time display.

■ Setting the time

To set the time, turn the ignition switch to “ACC” or “ON”. Press the “DISP” button and the “H” button together to advance the hours in one-hour increments. Press the “DISP” button and the “M” button together to advance the minutes in one-minute increments.

NOTE

If the connection between the radio and battery is broken for any reason such as vehicle maintenance or radio removal, the time setting will be cleared. If this occurs, it is necessary to reset the time.

AM/FM stereo radio with cassette player (if equipped)

The radio will operate only when the ignition switch is in the “ACC” or “ON” positions.

RADIO OPERATION

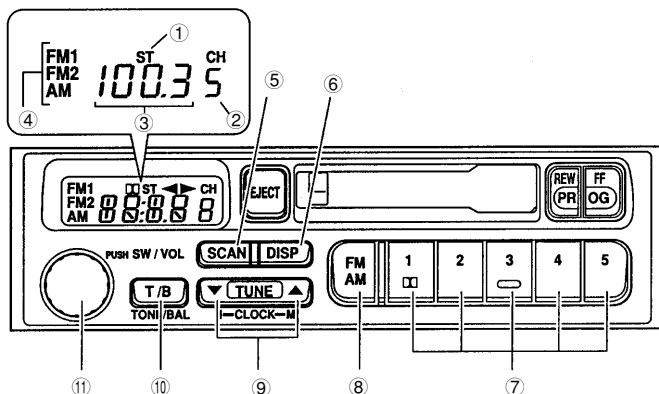

HB0318

- | | |
|-------------------------|--|
| ① Stereo indicator | ⑧ FM/AM selection button |
| ② Preset station number | ⑨ Tuning button |
| ③ Frequency | ⑩ TONE/BAL selection button |
| ④ Band | ⑪ Power switch, Volume control,
Bass/treble control and
Fader/balance control knob |
| ⑤ SCAN button | |
| ⑥ DISP button | |
| ⑦ Preset button | |

■ Power switch and volume control (SW/VOL)

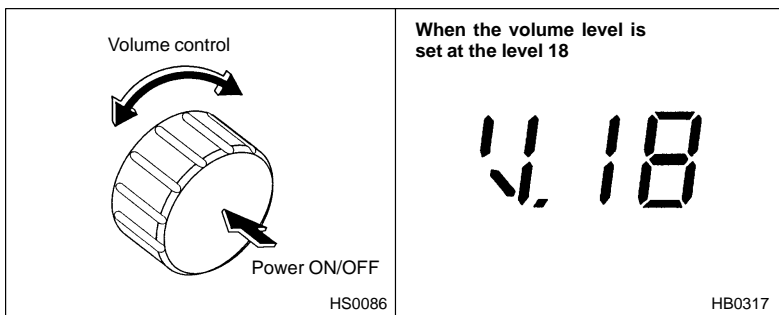

The same knob is used for both power (on/off) and volume control. The radio is turned on and off by pushing the knob and the volume is controlled by turning the knob.

The volume control has total of 41 volume levels (V: 0 for minimum, V: 40 for maximum).

■ Tone and balance control (TONE/BAL)

The volume control knob normally function as volume control. This knob become the controls for Bass, Treble, Fader or Balance when you select the relevant tone and balance control mode.

The “T/B” (Tone and balance) button is used for selecting the following control modes:

- Bass (low note) control
- Treble (high note) control
- Fader control (Volume balance control between front and rear speakers)
- Balance control (Volume balance control between right and left speakers)

To change control modes: Each pushing the “T/B” button changes control modes in the following sequence.

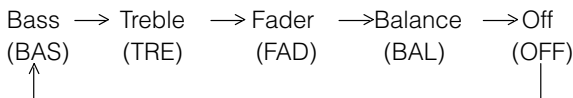

– CONTINUED –

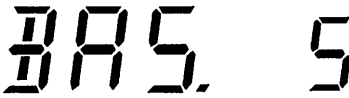

▼ Bass control

<p>Bass volume control indication</p>  <p>HB0344</p>	<p>When the bass volume level is set at the level 5</p>  <p>HB0319</p>
--	--

Select the Bass control mode by pressing the “T/B” button. In the bass control mode, the display shows the indication as shown.

The bass control has total of 11 volume levels (BAS. -5 for minimum, BAS. 0 for middle, BAS. 5 for maximum). Choose desired bass volume level by turning the volume control knob. The control function returns to volume control mode after about 5 seconds.

▼ Treble control

<p>Treble volume control indication</p>  <p>HB0346</p>	<p>When the treble volume level is set at the level -5</p>  <p>HB0320</p>
---	--

Select the Treble control mode by pressing the “T/B” button. In the treble control mode, the display shows the indication as shown.

The treble control has total of 11 volume levels (TRE. -5 for minimum, TRE. 0 for middle, TRE: 5 for maximum). Choose desired treble volume level by turning the volume control knob. The control function returns to volume control mode after about 5 seconds.

▼ Fader control

<p>Fader control indication</p> <p style="text-align: center; font-size: 2em; font-family: monospace;">FAD</p> <p style="text-align: right;">HG0089</p>	<p>When the fader setting is at the F9 (front maximum and rear minimum)</p> <p style="text-align: center; font-size: 2em; font-family: monospace;">FAD.F 9</p> <p style="text-align: right;">HB0321</p>
--	--

Select the Fader control mode by pressing the “T/B” button. In the fader control mode, the display shows the indication as shown.

The fader control has total of 19 settings (FAD. F9 for front maximum and rear minimum, FAD. 0 for neutral, FAD. R9 for front minimum and rear maximum). Choose desired setting by turning the volume control knob. The control function returns to volume control mode after about 5 seconds.

▼ Balance control

<p>Balance control indication</p> <p style="text-align: center; font-size: 2em; font-family: monospace;">BAL</p> <p style="text-align: right;">HB0345</p>	<p>When the balance setting is at the L9 (left side maximum and right side minimum)</p> <p style="text-align: center; font-size: 2em; font-family: monospace;">BAL.L 9</p> <p style="text-align: right;">HB0322</p>
--	--

Select the Balance control mode by pressing the “T/B” button. In the balance control mode, the display shows the indication as shown.

The balance control has total of 19 settings (BAL. L9 for left side max-

– CONTINUED –

imum and right side minimum, BAL. 0 for neutral, BAL. R9 for left side minimum and right side maximum). Choose desired setting by turning the volume control knob. The control function returns to volume control mode after about 5 seconds.

■ FM/AM selection button (FM AM)

Push the FM/AM selection button when the radio is on to select FM1, FM2 or AM reception. Each time this button is pressed, the band will change in the following order:



The display indicates which is currently selected.

■ Stereo indicator

The stereo indicator “ST” will come on when an FM stereo broadcast is received.

■ Manual tuning (TUNE)

Press the “TUNE” button marked “▲” to increase the tuning frequency and press the “TUNE” button marked “▼” to decrease it.

Each time the button is pressed, the frequency changes 10 KHz in the AM waveband and 0.2 MHz in the FM waveband.

Constant pressure on the button causes a continuous change in the frequency.

■ Automatic tuning (SCAN)

Press the “SCAN” button to change the radio to the SCAN mode. In this mode, the radio scans through the radio band until a station is found. The radio will stop at the station for five seconds while displaying the frequency, after which scanning will continue until the entire band has been scanned from the low end to the high end.

Press the “SCAN” button again to cancel the SCAN mode and to stop on any displayed frequency.

■ **Selecting preset stations**

Presetting a station with a preset button allows you to select that station in a single operation. Up to five AM, FM1 and FM2 stations each may be preset.

■ **How to preset stations**

1. Press the FM/AM selection button to select either FM1, FM2 or AM reception.
2. Press the "SCAN" button or tune the radio manually until the desired station frequency is displayed.
3. Press one of the preset buttons for **at least two seconds** to store the frequency. The frequency of the station will flash once on the display at this time. If the button is pressed for less than two seconds, the preceding selection will remain in memory.

When the "SCAN" button is pressed for automatic tuning, stations are scanned in the direction of low frequencies to high frequencies only.

Automatic tuning may not function properly if the station reception is weakened by distance from the station or proximity to tall buildings and hills.

NOTE

If the connection between the radio and battery is broken for any reason such as vehicle maintenance or radio removal, all stations stored in the preset buttons are cleared. If this occurs, it is necessary to reset the preset buttons.

CASSETTE PLAYER OPERATION

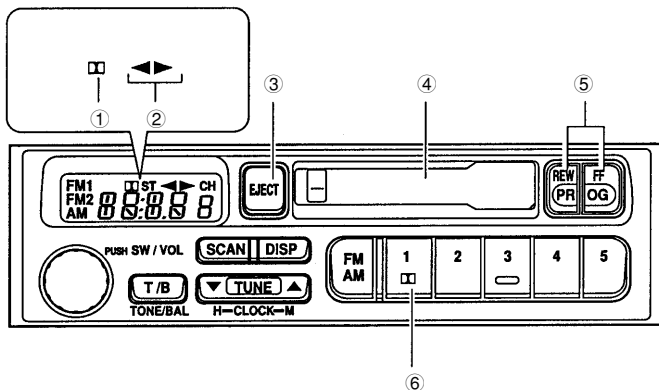

HB0323

- | | |
|-------------------------|--|
| ① Dolby NR indicator | ⑤ Program, Fast forward and
rewind button |
| ② Tape travel indicator | ⑥ Dolby NR button |
| ③ Eject button | |
| ④ Cassette slot | |

NOTE

- Only use good quality cassettes (cassettes longer than C-90 are not recommended).
- Put cassettes back in their boxes immediately after use to protect them from dust and dirt and to prevent the tape from unwinding.
- Never expose cassettes to heat, direct sunlight or moisture.
- Clean the tape head (once or twice a month) using a **wet-type cleaning cassette**.

■ Cassette slot

Insert a cassette with the exposed tape side facing to the right. After inserting, playback starts.

■ Tape travel indicators

These indicate the direction the cassette tape is moving.

- ▶ indicates that the top side of the cassette is being played back.
- ◀ indicates that the bottom side of the cassette is being played back.

■ Program switching buttons (PROG)

When the program switching buttons (“REW” and “FF” buttons) are pressed at the same time during playback, the tape travel indicators will switch and the player will begin playing back the opposite side of the tape. The same mechanism is automatically activated when the end of the tape is reached. This allows the opposite side of the tape to play, providing continuous playback.

■ Fast-forward button (FF)

To fast-forward the tape, press the “FF” button. To stop fast-forwarding, press the “REW” button.

■ Rewind button (REW)

To rewind the tape, press the “REW” button. To stop rewinding, press the “FF” button.

■ Stop and eject button (EJECT)

When “EJECT” button is pressed, play back stops and the cassette tape is ejected.

Before the ignition switch turn to the “OFF” position, eject the tape from the player. Always make certain that you remove the cassette tape.

■ Dolby NR button (□□)

Press “□□” button when playing tapes recorded using the Dolby NR system*. The “□□” indicator will light up and high-frequency noise on the tape will be reduced for clearer sound reproduction.

* Noise reduction system manufactured under license from Dolby Laboratories Licensing Corporation. “Dolby” and double-D Symbol are trade marks of Dolby Laboratories Licensing Corporation.

CLOCK FUNCTION

The radio has a built-in clock function that displays the time when the ignition switch is turned either to “ACC” or “ON”.

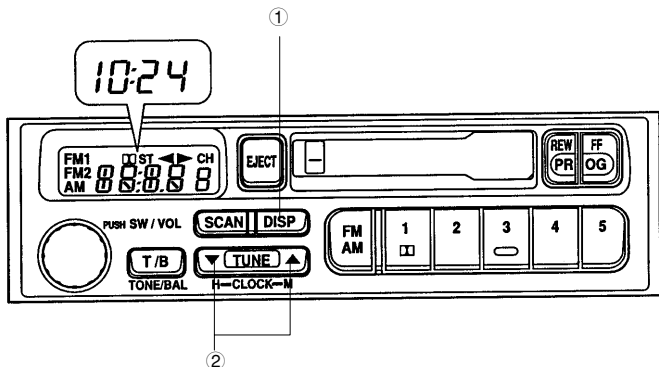

HB0324

- ① DISP button
- ② Tuning button

■ When turning on the radio

When the radio is switched on or the station is changed, the time display is replaced by the frequency display. However, after the frequency has been displayed for five seconds, it is replaced by the time display again.

If you wish to see the time while the frequency is being displayed, press the “DISP” button and the frequency display will be replaced with the time display.

■ Setting the time

1. Turn the ignition switch to “ACC” or “ON”.
2. **To adjust hour:** Press the “DISP” button and the “TUNE” button indicated with “▼” together to advance the hours in one-hour increments. Keeping the buttons pressed advances the hours quickly.
3. **To adjust minute:** Press the “DISP” button and the “TUNE” button indicated with “▲” together to advance the minutes in one-minute increments. Keeping the buttons pressed advances the minutes quickly.

NOTE

If the connection between the radio and battery is broken for any reason such as vehicle maintenance or radio removal, the time setting will be cleared. If this occurs, it is necessary to reset the time.

AM/FM/WB stereo radio with cassette and compact disc player (if equipped)

The radio will operate only when the ignition switch is in the "ACC" or "ON" positions.

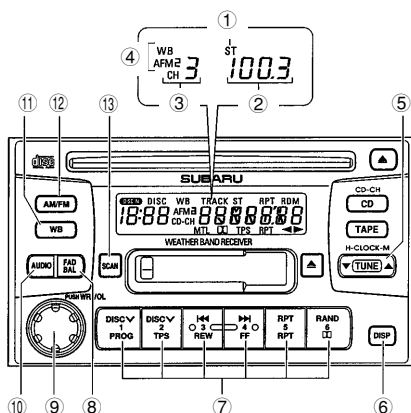
RADIO OPERATION

HB0326

- | | |
|----------------------------------|---|
| ① Stereo indicator | ⑨ Power switch, Volume control, Bass/Middle/Treble control and Fader/Balance control knob |
| ② Frequency | ⑩ AUDIO (audio mode) button |
| ③ Preset station number | ⑪ WB (weather band) button |
| ④ Wave band | ⑫ AM/FM selection button |
| ⑤ Tuning button | ⑬ SCAN button |
| ⑥ DISP button | |
| ⑦ Preset button | |
| ⑧ Fader/Balance selection button | |

- CONTINUED -

■ Power switch and volume control (PWR/VOL)

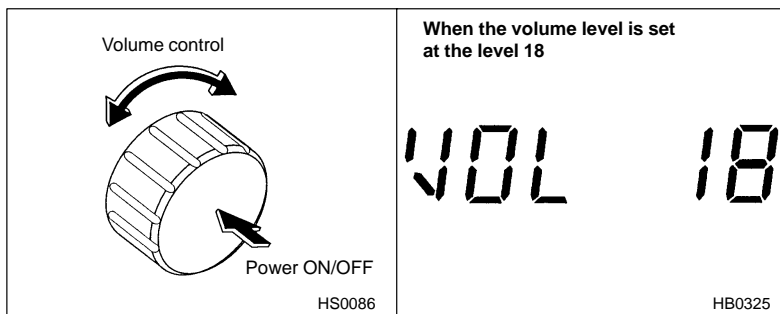

The same knob is used for both power (on/off) and volume control. The radio is turned on and off by pushing the knob and the volume is controlled by turning the knob.

The volume control has total of 41 volume levels (VOL 0 for minimum, VOL 40 for maximum).

■ Tone control (AUDIO)

The volume control knob normally function as volume control. This knob become the controls for Bass, Middle or Treble when you select the relevant tone control mode.



The "AUDIO" (audio mode) button is used for selecting the following control modes:

- Bass (low note) control
- Middle (middle note) control
- Treble (high note) control

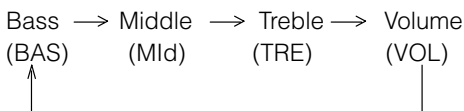
To change control modes: Each brief pushing the "AUDIO" button changes control modes in the following sequence starting from bass control mode. (When the radio is powered on, control mode is in the volume control.)





▼ Bass control

<p>Bass volume control indication</p>  <p>HB0347</p>	<p>When the bass volume level is set at the level 5</p>  <p>HB0327</p>
--	--

Select the Bass control mode by pressing the “AUDIO” button. In the bass control mode, the display shows the indication as shown.

The bass control has total of 11 volume levels (BAS. -5 for minimum, BAS. 0 for middle, BAS. 5 for maximum). Choose desired bass volume level by turning the volume control knob. The control function returns to volume control mode after about 5 seconds.

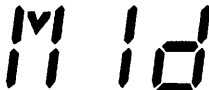
▼ Middle note control

<p>Middle note volume control indication</p>  <p>HB0329</p>	<p>When the middle note volume level is set at the level -3</p>  <p>HB0330</p>
--	---



Select the Middle note control mode by pressing the “AUDIO” button. In the middle note control mode, the display shows the indication as shown.

The middle note control has total of 11 volume levels (Mld. -5 for minimum, Mld. 0 for middle, Mld. 5 for maximum). Choose desired middle

– CONTINUED –

note volume level by turning the volume control knob. The control function returns to volume control mode after about 5 seconds.

▼ Treble control

<p>Treble volume control indication</p>  <p>HB0348</p>	<p>When the treble volume level is set at the level -5</p>  <p>HB0328</p>
---	--

Select the Treble control mode by pressing the “AUDIO” button. In the treble control mode, the display shows the indication as shown.

The treble control has total of 11 volume levels (TRE. -5 for minimum, TRE. 0 for middle, TRE. 5 for maximum). Choose desired treble volume level by turning the volume control knob. The control function returns to volume control mode after about 5 seconds.

■ Fader and balance control (FAD/BAL)

The volume control knob normally function as volume control. This knob become the controls for Fader or Balance when you select the relevant fader and balance control mode.

The “FAD/BAL” (fader and balance) button is used for selecting the following control modes:

- Fader control (Volume balance control between front and rear speakers)
- Balance control (Volume balance control between right and left speakers)

To change control modes: Each brief pushing the “FAD/BAL” button changes control modes in the following sequence starting from fader control mode. (When the radio is powered on, control mode is in the volume control.)

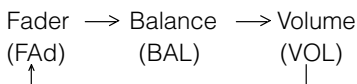

▼ Fader control

<p>Fader control indication</p> <p style="text-align: center; font-size: 2em;">FAd</p> <p style="text-align: right;">HB0368</p>	<p>When the fader setting is at the F9 (front maximum and rear minimum)</p> <p style="text-align: center; font-size: 2em;">FAd.F9</p> <p style="text-align: right;">HB0331</p>
--	---

Select the Fader control mode by pressing the “FAD/BAL” button. In the fader control mode, the display shows the indication as shown.

The fader control has total of 19 settings (FAd.F9 for front maximum and rear minimum, FAd.0 for neutral, FAd.R9 for front minimum and rear maximum). Choose desired setting by turning the volume control knob. The control function returns to volume control mode after about 5 seconds.

▼ Balance control

<p>Balance control indication</p> <p style="text-align: center; font-size: 2em;">BAL</p> <p style="text-align: right;">HB0349</p>	<p>When the balance setting is at the L9 (left side maximum and right side minimum)</p> <p style="text-align: center; font-size: 2em;">BAL.L9</p> <p style="text-align: right;">HB0332</p>
--	---

– CONTINUED –

Select the Balance control mode by pressing the “FAD/BAL” button. In the balance control mode, the display shows the indication as shown.

The balance control has total of 19 settings (BAL. L9 for left side maximum and right side minimum, BAL. 0 for neutral, BAL. R9 for left side minimum and right side maximum). Choose desired setting by turning the volume control knob. The control function returns to volume control mode after about 5 seconds.

■ AM/FM selection button (AM/FM)

Push the AM/FM button when the radio is off to turn on the radio.

Push the “AM/FM” button when the radio is on to select FM1, FM2 or AM reception. Each time this button is pressed, the band will change in the following order:



The display indicates which is currently selected.

■ Stereo indicator

The stereo indicator “ST” will come on when an FM stereo broadcast is received.

■ Weather band button (WB)

Push the “WB” button when the radio is off to turn on the radio in the weather band.

Press the “WB” button when the radio is on to select the weather band.

The weather band indicator “WB” will come on when the weather band is selected.

■ Manual tuning (TUNE)

▼ Manual tuning for AM and FM waveband

Push the tuning button marked “▲” to increase the tuning frequency and press the tuning button marked “▼” to decrease it.

Each time the button is pressed, the frequency changes 10 KHz in the AM waveband and 0.2 MHz in the FM waveband.

Constant pressure on the button causes a continuous change in the frequency.

▼ **Manual tuning for weather band**

When weather band mode is selected, press the tuning button marked “▲” to change the WB channel up and press the tuning button marked “▼” to change the WB channel down. Each time the button is pressed, the WB channel changes next channel. Constant pressure on the button causes a continuous change in the frequency.

■ **Automatic tuning (SCAN)**

Press the “SCAN” button to change the radio to the SCAN mode. In this mode, the radio scans through the radio band until a station is found. The radio will stop at the station for five seconds while displaying the frequency, after which scanning will continue until the entire band has been scanned from the low end to the high end.

Press the “SCAN” button again to cancel the SCAN mode and to stop on any displayed frequency.

■ **Selecting preset stations**

Presetting a station with a preset button allows you to select that station in a single operation. Up to six AM, FM1, FM2 and WB stations each may be preset.

■ **How to preset stations**

1. Press the AM/FM selection button to select either AM, FM1 or FM2 reception.

OR

Press the “WB” button to select the weather band.

2. Press the “SCAN” button or tune the radio manually until the desired station frequency is displayed.

3. Press one of the preset buttons for **at least 1.5 seconds** to store the frequency. The frequency of the station will flash once on the display at this time. If the button is pressed for less than 1.5 seconds, the preceding selection will remain in memory.

– **CONTINUED** –

When the "SCAN" button is pressed for automatic tuning, stations are scanned in the direction of low frequencies to high frequencies only. Automatic tuning may not function properly if the station reception is weakened by distance from the station or proximity to tall buildings and hills.

NOTE

If the connection between the radio and battery is broken for any reason such as vehicle maintenance or radio removal, all stations stored in the preset buttons are cleared. If this occurs, it is necessary to reset the preset buttons.

CASSETTE PLAYER OPERATION

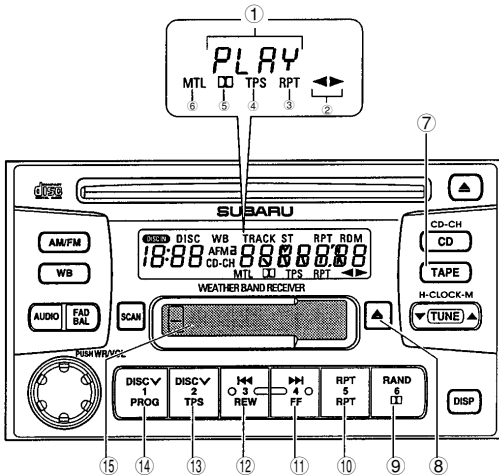

HB0333

- | | |
|---|----------------------------|
| ① Cassette player operation indicator | ⑧ Eject button |
| ② Tape travel indicator | ⑨ Dolby NR button |
| ③ Repeat indicator | ⑩ Repeat button |
| ④ TPS indicator | ⑪ Fast forward button |
| ⑤ Dolby NR indicator | ⑫ Rewind button |
| ⑥ Metal tape indicator | ⑬ TPS button |
| ⑦ TAPE (cassette player selection) button | ⑭ Program switching button |
| | ⑮ Cassette slot |

NOTE

- Only use good quality cassettes (cassettes longer than C-90 are not recommended).
- Put cassettes back in their boxes immediately after use to protect them from dust and dirt and to prevent the tape from unwinding.
- Never expose cassettes to heat, direct sunlight or moisture.
- Clean the tape head (once or twice a month) using a **wet-type cleaning cassette**.

■ To play back a cassette tape**▼ When cassette tape is not in the player**

When a cassette is partially inserted, it is automatically drawn in and starts tape playback.

▼ When cassette tape is in the player

When the "TAPE" button is pressed, the display will indicate "PLAY" and the player will start playback.

■ Tape travel indicators

These indicate the direction the cassette tape is moving.

- ▶ indicates that the top side of the cassette is being played back.
- ◀ indicates that the bottom side of the cassette is being played back.

■ Program switching button (PROG)

When the program switching button "PROG" is pressed during playback, the tape travel indicators will switch and the player will begin playing back the opposite side of the tape. The same mechanism is automatically activated when the end of the tape is reached. This allows the opposite side of the tape to play, providing continuous playback.

■ Fast-forward button (FF)

To fast-forward the tape, press the "FF" button. The display will indicate "FF". To stop fast-forwarding, press the "FF" or "TAPE" button.

■ Rewind button (REW)

To rewind the tape, press the “REW” button. The display will indicate “REW”. To stop rewinding, press the “REW” or “TAPE” button.

■ Stop and eject button (▲)

When “▲” button is pressed, play back stops and the cassette tape is ejected.

The ejection function also operates when the ignition switch is turned off. Always make certain that you remove the cassette tape.

■ Tape program sensor button (TPS)

▼ Blank skip

When the “TPS” button is pressed, the “TPS” indicator will come on and the player will automatically skip any blank portion of 15 second or more and play the next program, even if it is on the other side. To cancel blank skip mode, press the “TPS” button again.

▼ Blank search

Press “TPS” button during playback to return to the beginning of the current selection or to skip to the beginning of the next selection. To use this function, press the “TPS” button to turn on the “TPS” indicator. If the fast-forward button “FF” is then pressed, the player advances the tape to the beginning of the next selection and starts playing it. If the rewind button “REW” is pressed instead, the player rewinds the tape to the beginning of the current selection and starts replaying it. The “TPS” function may not operate properly under the following conditions:

- When the recording level is low.
- When there are long pauses in the middle of a selection.
- When the tape contains verbal material such as conversations.
- When the blanks between selections are shorter than five seconds.
- When there are no blanks between selections (live concerts, etc.).

■ Repeat button (RPT)

Push the “RPT” button to repeat the piece of music being listened to. To use this function, push the “RPT” button while the piece you want to hear

again is being played. "RPT" will be indicated on the display. When the selection ends, the cassette player automatically rewinds to the beginning of the piece and the selection begins again. To cancel the repeat function, push the "RPT" button again. Until the repeat function is cancelled, the same piece of music will be repeated indefinitely. The "RPT" function may not operate properly under the following conditions:

- When the recording level is low.
- When there are long pauses in the middle of a selection.
- When the tape contains verbal material such as conversations.
- When the blanks between selections are shorter than five seconds.
- When there are no blanks between selections (live concerts, etc).

■ **Dolby NR button ()**

Press " " button when playing tapes recorded using the Dolby NR system*. The " " indicator will light up and high-frequency noise on the tape will be reduced for clearer sound reproduction.

* Noise reduction system manufactured under license from Dolby Laboratories Licensing Corporation. "Dolby" and double-D Symbol are trade marks of Dolby Laboratories Licensing Corporation.

■ **Auto metal sensor**

The cassette player automatically adjusts for metal or CrO₂ tape.

■ **Metal tape button (MTL)**

If metal or CrO₂ tape has been inserted into the cassette slot, "MTL" will be indicated on the display.

COMPACT DISC PLAYER OPERATION

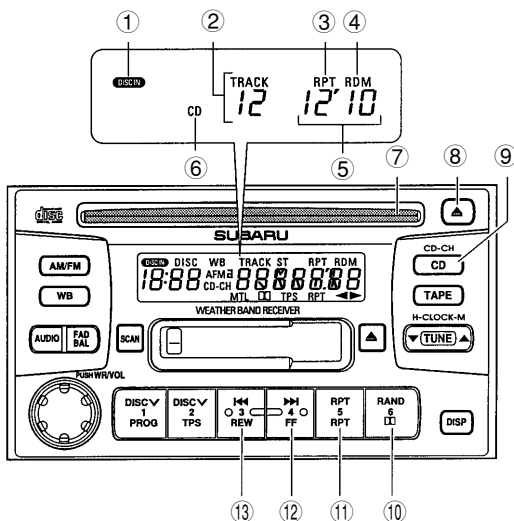

HB0334

- | | |
|----------------------------|--------------------------------------|
| ① DISC indicator | ⑨ CD (CD player selection) button |
| ② Track number | ⑩ Random button |
| ③ Repeat indicator | ⑪ Repeat button |
| ④ Random indicator | ⑫ Fast forward and track up button |
| ⑤ Time elapsed | ⑬ Fast reverse and track down button |
| ⑥ CD player made indicator | |
| ⑦ Disc slot | |
| ⑧ Eject button | |

■ To play back a compact disc

▼ When CD is not in the player

Hold a disc with a finger in the center hole while gripping the edge of the disc, then insert it in to the slot (with the label side up) and the player will automatically pull the disc into position.

After inserting, the DISC indicator "DISC IN" and CD player mode indicator "CD" will come on and playback start.

NOTE

- Make sure to always insert a disc with the label side up. If a disc is inserted with the label side down, it might be ejected or the player might shut off.
- After the last song finishes, the disc will automatically return to track 1 (the first song on the disc) and will automatically play back.

▼ When CD is in the player

When the “CD” button is pressed, the CD player mode indicator “CD” will come on and the player will start playback.

NOTE

After the last song finishes, the disc will automatically return to track 1 (the first song on the disc) and will automatically play back.

■ To select a song from its beginning**▼ Forward direction**

Briefly press the “▶▶■” button to skip to the beginning of the next track. Each time the button is pressed, the indicated track number will increase.

▼ Backward direction

Briefly press the “■◀◀” button to skip to the beginning of the current track. Each time the button is pressed, the indicated track number will decrease.

■ Fast forwarding and fast reverse**▼ Fast forward**

Press the “▶▶▶” button continuously for more than 0.5 second to fast forward the disc.

Release the button to stop fast forwarding.

▼ Fast reverse

Press the “◀◀◀” button continuously for more than 0.5 second to fast reverse the disc.

Release the button to stop fast reverse.

■ Repeat playback

Press the “RPT” button while a song is playing to play the song repeatedly. The “RPT” indicator will come on and the song will be played continuously. To cancel the repeat mode, press the button again. Then the “RPT” indicator goes out, and normal playback mode is restored.

■ Random playback

Press the “RDM” button while a disc is being played back to play all songs on the disc in a random order. The “RDM” indicator will come on and all songs on the disc will be played in a random order. To cancel the random mode, press the button again. Then the “RDM” indicator goes out, and normal playback mode is restored.

■ Scan

When the “SCAN” button is pressed while the disc is being played back, you can hear the first 10 seconds of each track to search the desired program. To continue listening to the program, press the “SCAN” button again. After all tracks on the disc has been scanned, normal playback mode is restored.

■ To eject a disc from the player

When a disc is being played back or when a disc is in the player, press the eject button “▲”. The disc will be ejected. The disc may be removed even when the ignition switch is in the “LOCK” position.

NOTE

Avoid driving the vehicle with a CD sticking out, because vibration might make it fall out.

■ Precautions to observe when handling a compact disc (CD)

- To remove a disc from the case, press the center of the case and hold both edges of the disc. If the disc surface is touched directly, contamination could cause poor tone quality. Do not touch the disc surface.
- Use a clean disc whenever possible. If there are deposits, wipe the disc surface from the center outward with a dry, soft cloth. Be sure not to

use a hard cloth, thinner, benzene, alcohol, etc.

- Never use a badly damaged, deformed or cracked disc. Malfunctions or problems might result.
- A disc is vulnerable to heat. Never keep it either in places exposed to direct sunlight or near heaters.

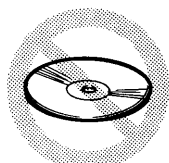
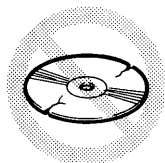
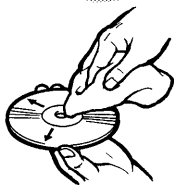
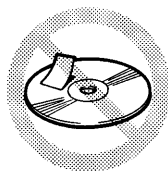
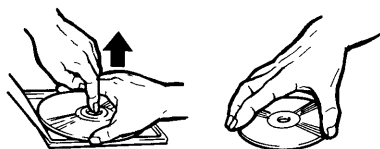

OM-4747

– CONTINUED –

CD CHANGER CONTROL (If optional CD changer is connected)

An optional CD changer can be connected to this audio unit. See your SUBARU dealer for more information.

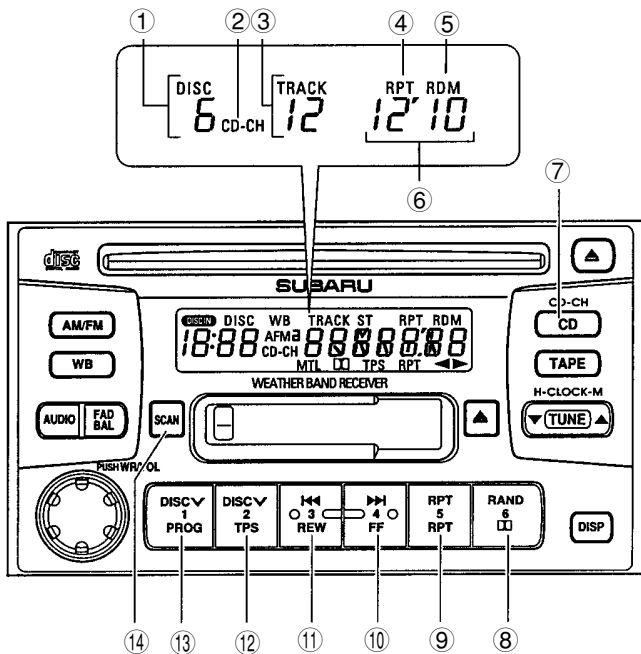

HB0335

- | | |
|--|--------------------------------------|
| ① Disc number | ⑧ Random button |
| ② CD-CH (CD changer mode) indicator | ⑨ Repeat button |
| ③ Track number | ⑩ Fast forward and track up button |
| ④ Repeat indicator | ⑪ Fast reverse and track down button |
| ⑤ Random indicator | ⑫ Disc up button |
| ⑥ Time elapsed | ⑬ Disc down button |
| ⑦ CD-CH (CD changer mode selection) button | ⑭ SCAN button |

■ To start playback

When the “CD-CH” button is pressed, the CD changer mode indicator “CD-CH” will come on and the CD changer will start playback. The display shows the current disc number, track number and the elapsed time during playback.

NOTE

- If a disc is in the player, the “CD-CH” button (“CD” button) is used to change from CD player operation to CD changer operation. Each time the “CD-CH” button is pressed, the operating mode will change alternately starting from CD player mode.
- At the end of the disc, playback automatically continues with the next disc.
- After playback on the last disc finishes, the disc will automatically return to the first disc and will automatically play back.
- If you have loaded fewer than 6 discs, any missing disc is automatically skipped.

■ To select the desired disc

Press either the disc up button “DISC \wedge ” or disc down button “DISC \vee ” to select the desired disc. Each time the “DISC \wedge ” button is pressed, the indicated disc number will increase. Each time the “DISC \vee ” button is pressed, the indicated disc number will decrease. Constant pressure on these buttons causes a continuous change in the disc number.

■ To select a song from its beginning

▼ Forward direction

Briefly press the “▶▶▶” button to skip to the beginning of the next track. Each time the button is pressed, the indicated track number will increase.

▼ Backward direction

Briefly press the “◀◀◀” button to skip to the beginning of the current track. Each time the button is pressed, the indicated track number will decrease.

■ Fast forwarding and fast reverse

▼ Fast forward

Press the “▶▶▶” button continuously for more than 0.5 second to fast forward the disc.

Release the button to stop fast forwarding.

If you continue fast forwarding to the end of the disc, the CD changer will automatically stop fast forwarding and start playback beginning with the first track on the current disc.

▼ Fast reverse

Press the “◀◀◀” button continuously for more than 0.5 second to fast reverse the disc.

Release the button to stop fast reverse.

If you continue fast reverse to the beginning of the disc, the CD changer will automatically stop fast reverse and start playback beginning with the first track on the current disc.

■ Repeat playback

Press the “RPT” button while a song is playing to play the song repeatedly. The “RPT” indicator will come on and the song will be played continuously. To cancel the repeat mode, press the button again. Then the “RPT” indicator goes out, and normal playback mode is restored.

■ Random playback

Press the “RDM” button while a disc is being played back to play all songs on the disc in a random order. The “RDM” indicator will come on and all songs on the disc will be played in a random order.

To cancel the random mode, press the button again. Then the “RDM” indicator goes out, and normal playback mode is restored.

■ Scan

When the “SCAN” button is pressed while the disc is being played back, you can hear the first 10 seconds of each track to search the desired program. To continue listening to the program, press the “SCAN” button again. After all tracks on the disc has been scanned, normal playback mode is restored.

CLOCK FUNCTION

The radio has a built-in clock function that displays the time when the ignition switch is tuned either to “ACC” or “ON”.

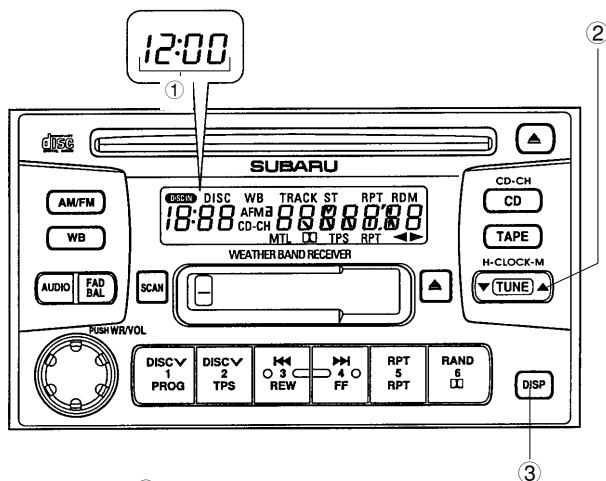

- ① Time
- ② CLOCK button
- ③ DISP button

HB0336

■ Display mode

You can select either the time display mode or function display mode by pressing the “DISP” button continuously for more than 0.5 second.

▼ Time display mode

When the time display mode is selected, the time display takes priority of the function display. The time is shown on the display whenever the ignition switch is “ACC” or “ON” position.

When the CD changer is switched on or the disc in the CD changer is changed during the time display mode, the time display is replaced by the disc number display. However, after the disc number has been displayed for five seconds, it is replaced by the time display again.

– CONTINUED –

▼ Function display mode

When the function display mode is selected, the time is not shown on the display. The display indicates the current function only.

■ Setting the time

1. Turn the ignition switch to “ACC” or “ON”.
2. Select the time display mode by pressing the “DISP” button for more than 0.5 second.
3. **To adjust hour:** Press the “DISP” button and the “H” button together to advance the hours in one-hour increments. Keeping the buttons pressed advances the hours quickly.
4. **To adjust minute:** Press the “DISP” button and the “M” button together to advance the minutes in one-minute increments. Keeping the buttons pressed advances the minutes quickly.

NOTE

If the connection between the radio and battery is broken for any reason such as vehicle maintenance or radio removal, the time setting will be cleared. If this occurs, it is necessary to reset the time.

Installation of accessories

Always consult your SUBARU dealer before installing a citizen band radio or other transmitting device in your vehicle. Such devices may cause the electronic control system to malfunction if they are incorrectly installed or if they are not suited for the vehicle.