

B5M0448A

2. Door

A: REMOVAL AND INSTALLATION

1. DOOR ASSEMBLY

1) Remove lower trim and disconnect connectors from body harness.

2) Place a cloth or a wood block under door to prevent damage, and support it with a jack.

3) Remove checker pin by driving it upward. Be careful not to damage door and body.

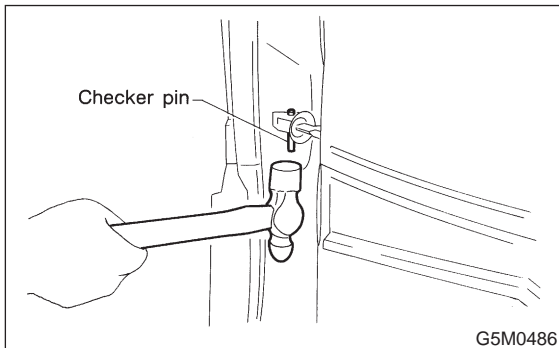

4) Remove bolts (M8) securing upper and lower hinges to door, and remove door from hinges.

Tightening torque:

$25 \pm 3 \text{ N}\cdot\text{m}$ ($2.5 \pm 0.3 \text{ kg}\cdot\text{m}$, $18.1 \pm 2.2 \text{ ft}\cdot\text{lb}$)

5) Remove hinges by loosening hinges mounting bolt (M8) off of body.

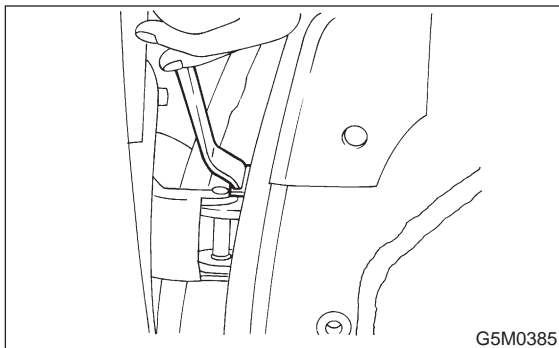

CAUTION:

Work carefully to avoid damaging door.

6) Installation is in the reverse order of removal.

Tightening torque:

$29 \pm 5 \text{ N}\cdot\text{m}$ ($3.0 \pm 0.5 \text{ kg}\cdot\text{m}$, $21.7 \pm 3.6 \text{ ft}\cdot\text{lb}$)

NOTE:

Apply grease to moving parts of door hinges.

2. TRIM PANEL

1) Press retainer spring (A) with a thin flat bladed screwdriver and then remove regulator handle (B). (models without power window)

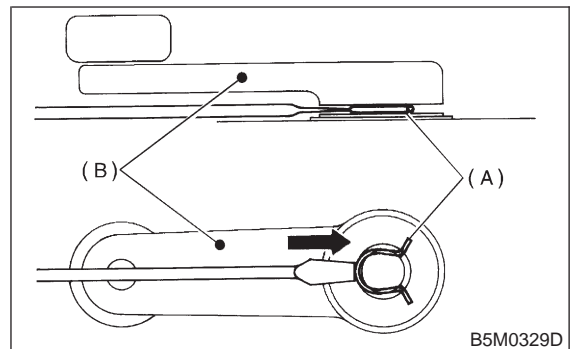

2) Remove gusset cover (A) and three screws.

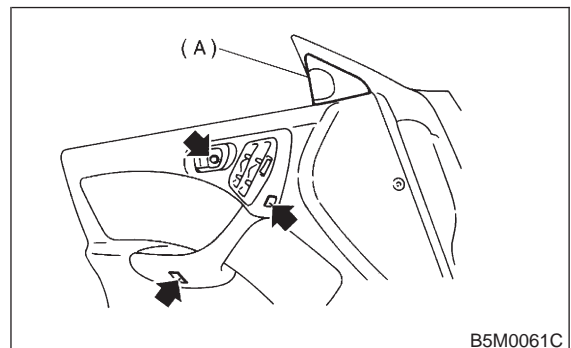

3) Using ST, disengage the clip.
ST 925580000 PULLER

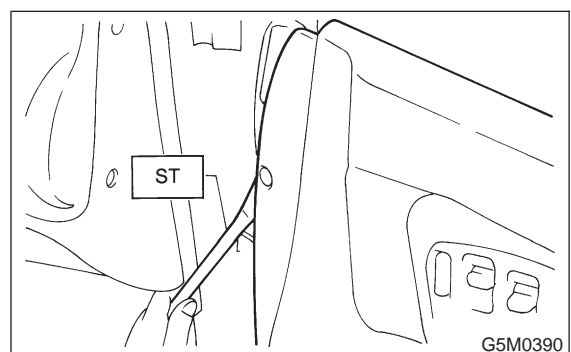

4) Remove trim panel and then disconnect connector. (models with power window)

CAUTION:

Be careful not to break clip by applying undue force.

5) Installation is in the reverse order of removal.

3. SEALING COVER

- 1) Remove trim panel. <Ref. to 5-2 [W2A2].>
- 2) Remove speaker, remote assembly and disconnect connectors.
- 3) Remove sealer with a spatula.

CAUTION:

Be careful because cover may break if sealer is removed forcefully.

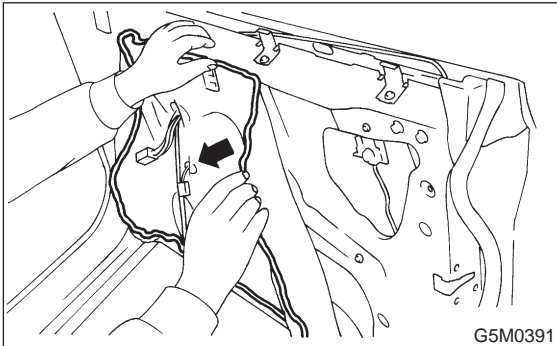

4) Installation is in the reverse order of removal.

NOTE:

- Confirm that sealer is properly applied without breaks. Then install sealing cover.
- When repairing or replacing sealing cover, use "CEMEDINE 5430L" as sealer. It may be overlaid on existing sealer.

Sealer:

CEMEDINE 5430L

CAUTION:

- Any breaks in sealer can cause water leakage or entry of air and dust. Be sure sealer is applied in a continuous line.
- Do not stop up drain hole (A) with sealer.
- Do not stop up install hole with (B) sealing cover.

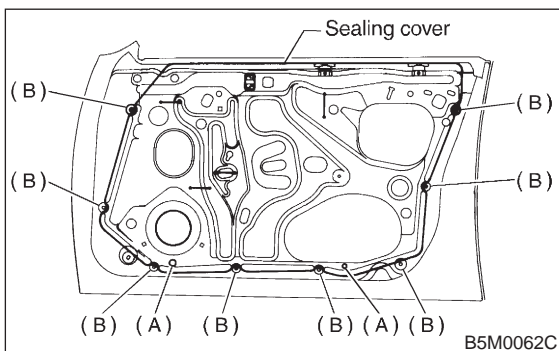

- Make sure sealing cover bonded areas are free from wrinkles or openings.

4. CHECKER

- 1) Remove trim panel. <Ref. to 5-2 [W2A2].>
- 2) Remove sealing cover. <Ref. to 5-2 [W2A3].>

- 3) Apply a cloth to door and body to prevent damaging them, and remove checker pin by driving it upward.

CAUTION:

Be careful not to damage door and body.

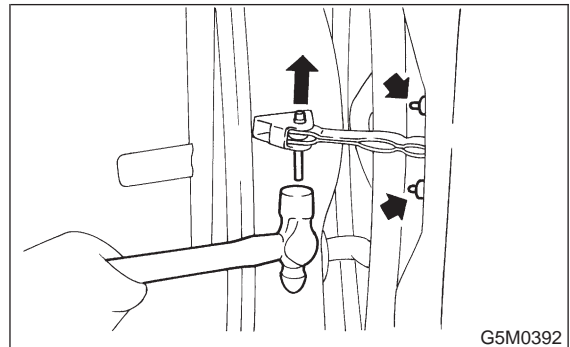

- 4) Completely close door glass.
- 5) Loosen two nuts securing checker, and take out checker through access hole in underside.
- 6) Installation should be made in the reverse order of removal.

Tightening torque:

7.4±2.0 N·m (0.75±0.2 kg·m, 5.4±1.4 ft·lb)

5. DOOR GLASS

- 1) Remove trim panel. <Ref. to 5-2 [W2A2].>
- 2) Remove sealing cover. <Ref. to 5-2 [W2A3].>
- 3) Disconnect door mirror connector and then remove gusset (A). <Ref. to 5-2 [W2A10].>

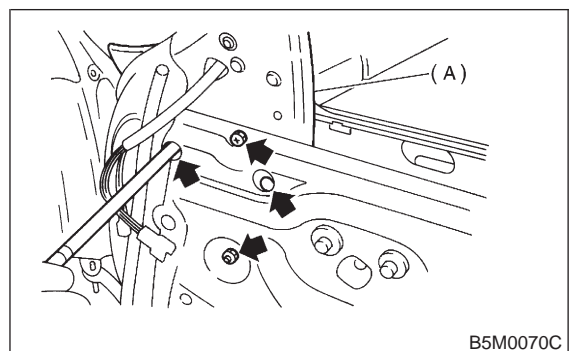

- 4) Remove inner remote. <Ref. to 5-2 [W2A6].>
- 5) Remove inner stabilizer (A).

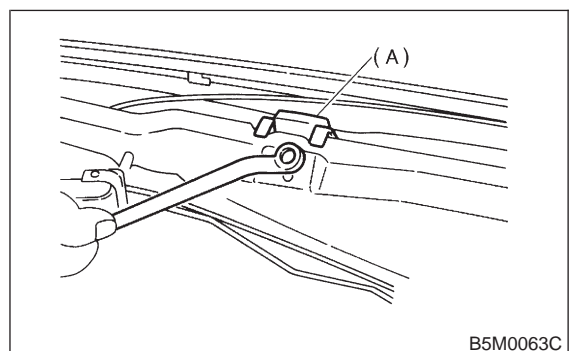

- 6) Remove nut and then separate glass holder (A) from guide channel A (B).

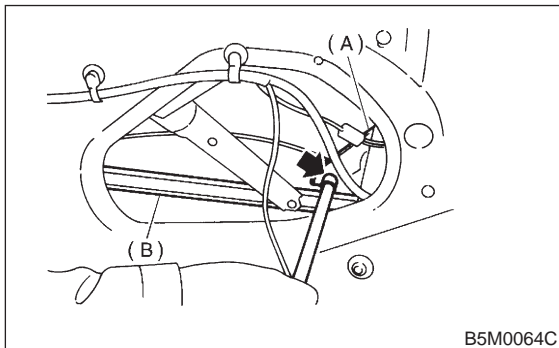

NOTE:

When removing nut, move door window lower glass connecting section to service hole of door panel.

- 7) Remove window glass upward.

CAUTION:

After removing window glass, do not move regulator.

- 8) Remove regulator installing bolt and guide channel B installing nut.

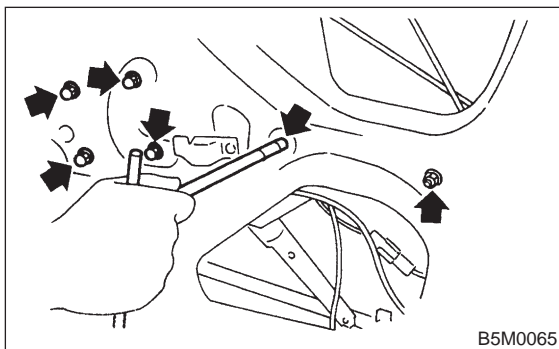

- 9) Remove regulator through lower service hole of door panel.

- 10) Installation is in the reverse order of removal.

6. INNER REMOTE

- 1) Remove trim panel. <Ref. to 5-2 [W2A2].>
- 2) Remove sealing cover. <Ref. to 5-2 [W2A3].>
- 3) Disconnect joints of two rods.

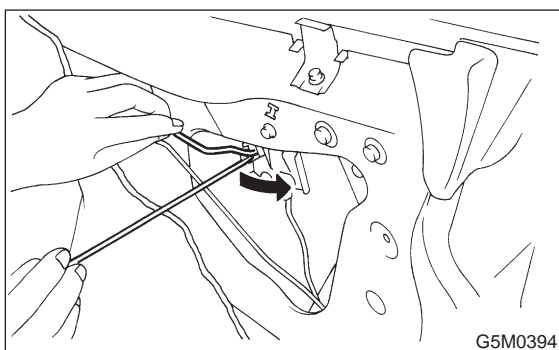

- 4) Unlatch rod holder.

- 5) Remove remote holder (A) and then remove inner remote assembly (B).

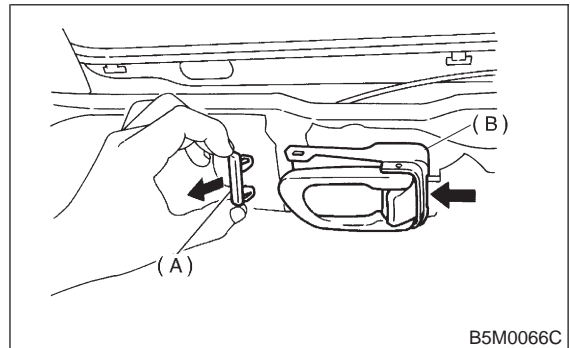

- 6) Installation is in the reverse order of removal.

NOTE:

- After passing two rods through holder, attach remote assembly to inner panel.
- Latch rod holder.

- 7) Lock the door and then loosen bolt (A).

- 8) Lower bell-crank (B) and then tighten bolt (A).

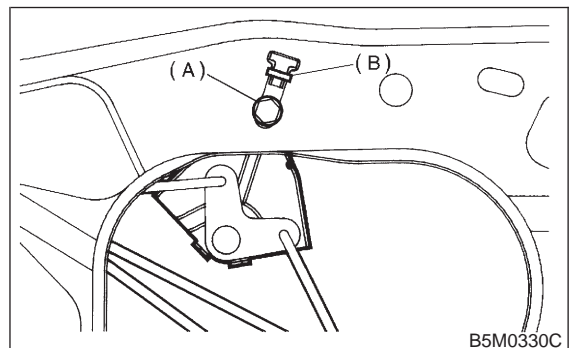

NOTE:

If rear door is equipped with child safety lock, check that child lock lever moves without dragging.

7. DOOR LATCH

- 1) Remove trim panel. <Ref. to 5-2 [W2A2].>
- 2) Remove inner remote assembly. <Ref. to 5-2 [W2A6].>
- 3) Remove sealing cover around latch service hole. <Ref. to 5-2 [W2A3].>
- 4) Completely close door glass.
- 5) Remove latch and actuator assembly:

- (1) Turn rod holder to disconnect joint between key lock and rod.
- (2) Turn rod holder to disconnect joint between outer handle and rod.
- (3) Turn rod holder to disconnect joint between crank and rod.

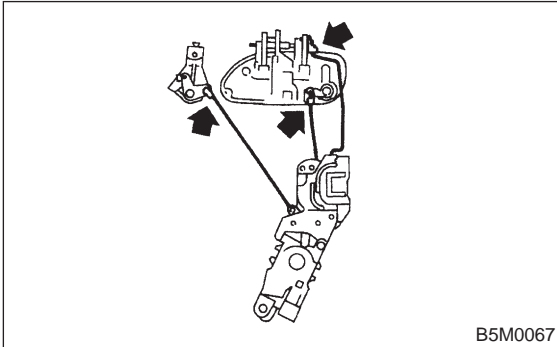

- 6) Loosen screws securing both latch and actuator, then remove latch and actuator assembly through service hole in bottom.

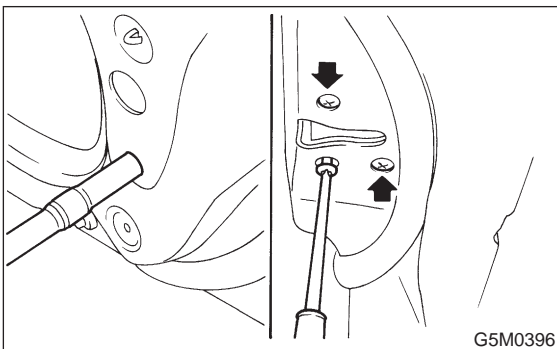

- 7) Installation is in the reverse order of removal.

Tightening torque:
 $6.4 \pm 2.0 \text{ N}\cdot\text{m}$ ($0.65 \pm 0.2 \text{ kg}\cdot\text{m}$, $4.7 \pm 1.4 \text{ ft}\cdot\text{lb}$)

NOTE:

- Check operation of each part.
- Check each sliding part for proper lubrication.

CAUTION:

After installation, be sure lock mechanism operates normally.

8. OUTER HANDLE

- 1) Remove trim panel. <Ref. to 5-2 [W2A2].>
- 2) Remove sealing cover. <Ref. to 5-2 [W2A3].>
- 3) Detach door latch rod from outer handle and key lock.

- 4) Loosen nut securing outer handle and then remove outer handle from outside.

CAUTION:

Be careful not to damage door.

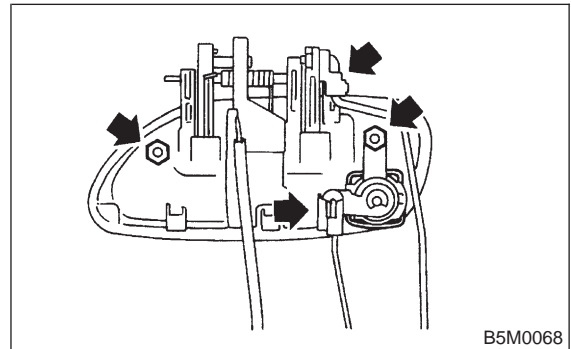

- 5) Installation is in the reverse order of removal.

Tightening torque:

$7.4 \pm 2.0 \text{ N}\cdot\text{m}$ ($0.75 \pm 0.2 \text{ kg}\cdot\text{m}$, $5.4 \pm 1.4 \text{ ft}\cdot\text{lb}$)

9. KEY LOCK

- 1) Remove trim panel. <Ref. to 5-2 [W2A2].>
- 2) Remove sealing cover. <Ref. to 5-2 [W2A3].>
- 3) Completely close door glass.
- 4) Remove outer handle. <Ref. to 5-2 [W2A8].>
- 5) Loosen spring (A) securing key lock.

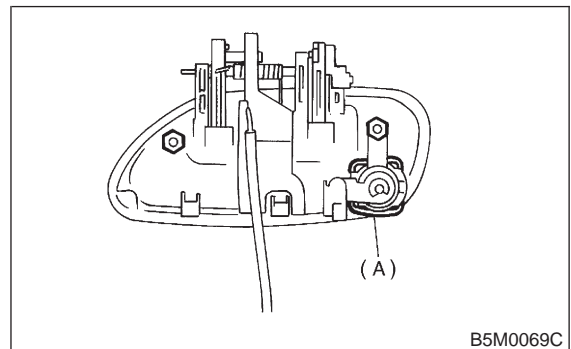

- 6) Remove key lock from outer handle.
- 7) Installation is in the reverse order of removal.

NOTE:

Install so that key slot in key lock comes to center of hole in outer handle.

10. GUSSET

- 1) Be sure window is all the way down.
- 2) Remove trim panel. <Ref. to 5-2 [W2A2].>
- 3) Remove door rearview mirror.
- 4) Remove sealing cover. <Ref. to 5-2 [W2A3].>
- 5) Remove bolts and nuts which secure gusset (A).
- 6) Lift out gusset (A).

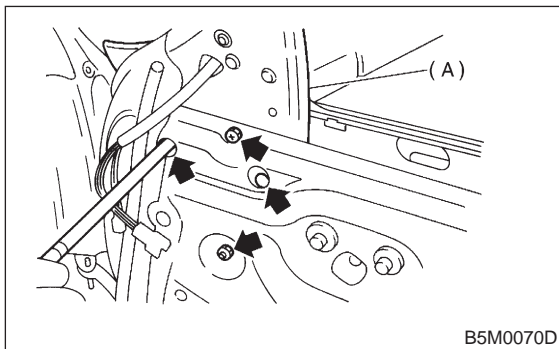

- 7) Installation is in the reverse order of removal.

11. REAR DOOR CATCHER

- 1) Open the rear door.
- 2) Using TORX®BIT (Tamper resistant type), remove rear door catcher.

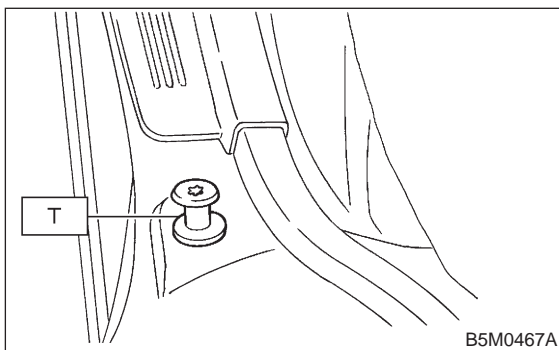

- 3) Installation is in the reverse order of removal.

Tightening torque:

$37 \pm 10 \text{ N}\cdot\text{m}$ ($3.8 \pm 1.0 \text{ kg}\cdot\text{m}$, $27.5 \pm 7.2 \text{ ft}\cdot\text{lb}$)

B: ADJUSTMENT

1. DOOR ASSEMBLY

- 1) Using ST, loosen bolts securing upper and lower hinges to body, and adjust fore-and-aft and vertical alignment of door.

ST 925610000 DOOR HINGE WRENCH

- 2) Loosen mounting screws approximately one rotation. Adjust striker (A) position by lightly tapping with hammer. (To adjust, utilize the shape of striker nut plate support (B).)

CAUTION:

- Use cloth to prevent damaging body or other parts.
- Do not directly tap striker plastic portion.
- Do not apply impact on spot-welded striker nut plate.

Hinge tightening torque (body side):

$29 \pm 5 \text{ N}\cdot\text{m}$ ($3.0 \pm 0.5 \text{ kg}\cdot\text{m}$, $21.7 \pm 3.6 \text{ ft}\cdot\text{lb}$)

Striker tightening torque:

$14 \pm 4 \text{ N}\cdot\text{m}$ ($1.4 \pm 0.4 \text{ kg}\cdot\text{m}$, $10.1 \pm 2.9 \text{ ft}\cdot\text{lb}$)

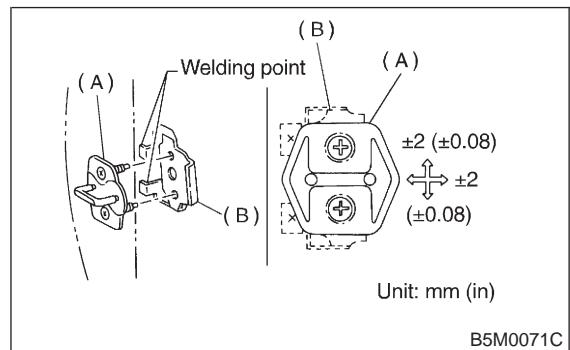

2. PROCEDURE CHART FOR ADJUSTING DOOR GLASS

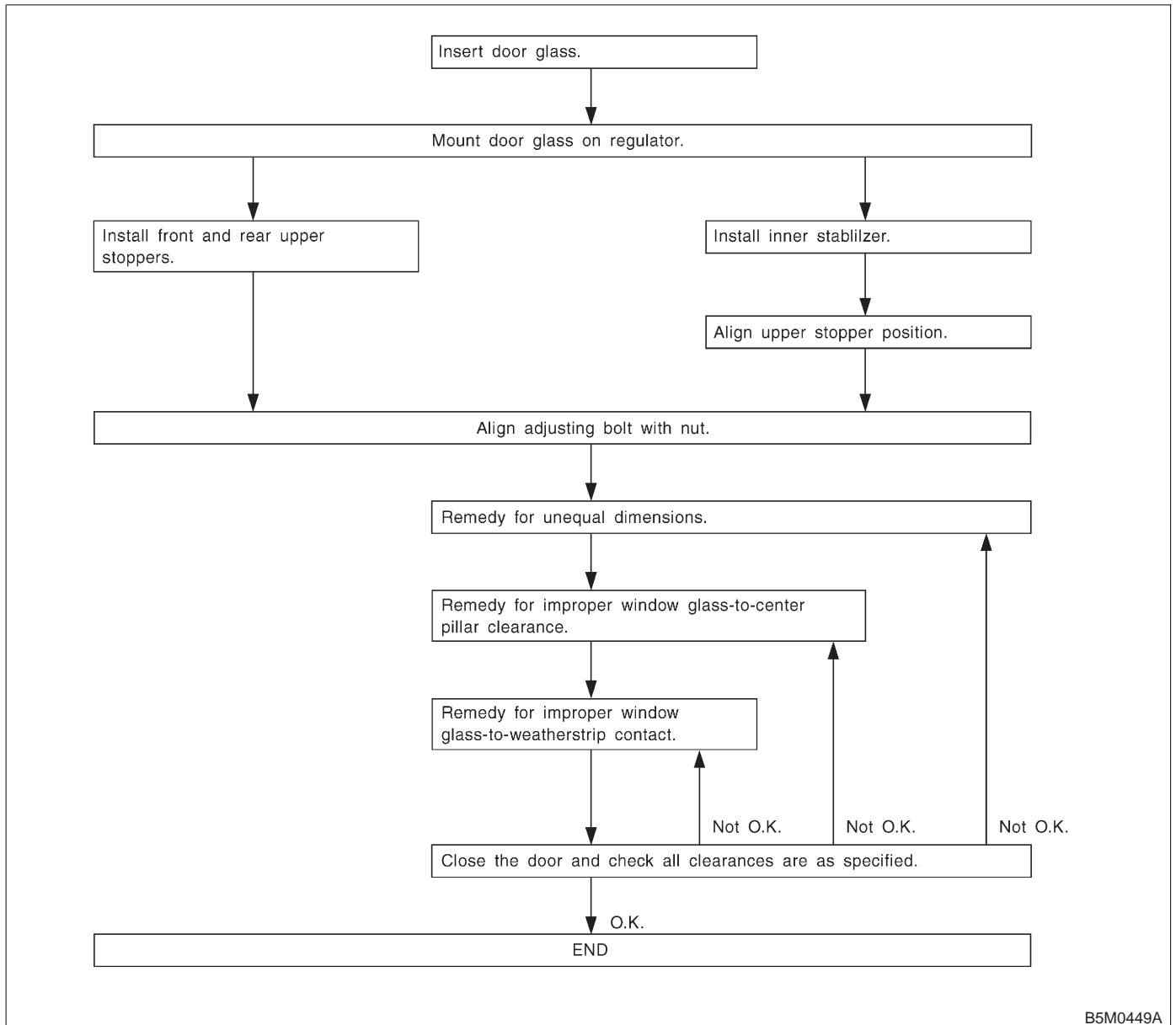

B5M0449A

3. FRONT DOOR GLASS

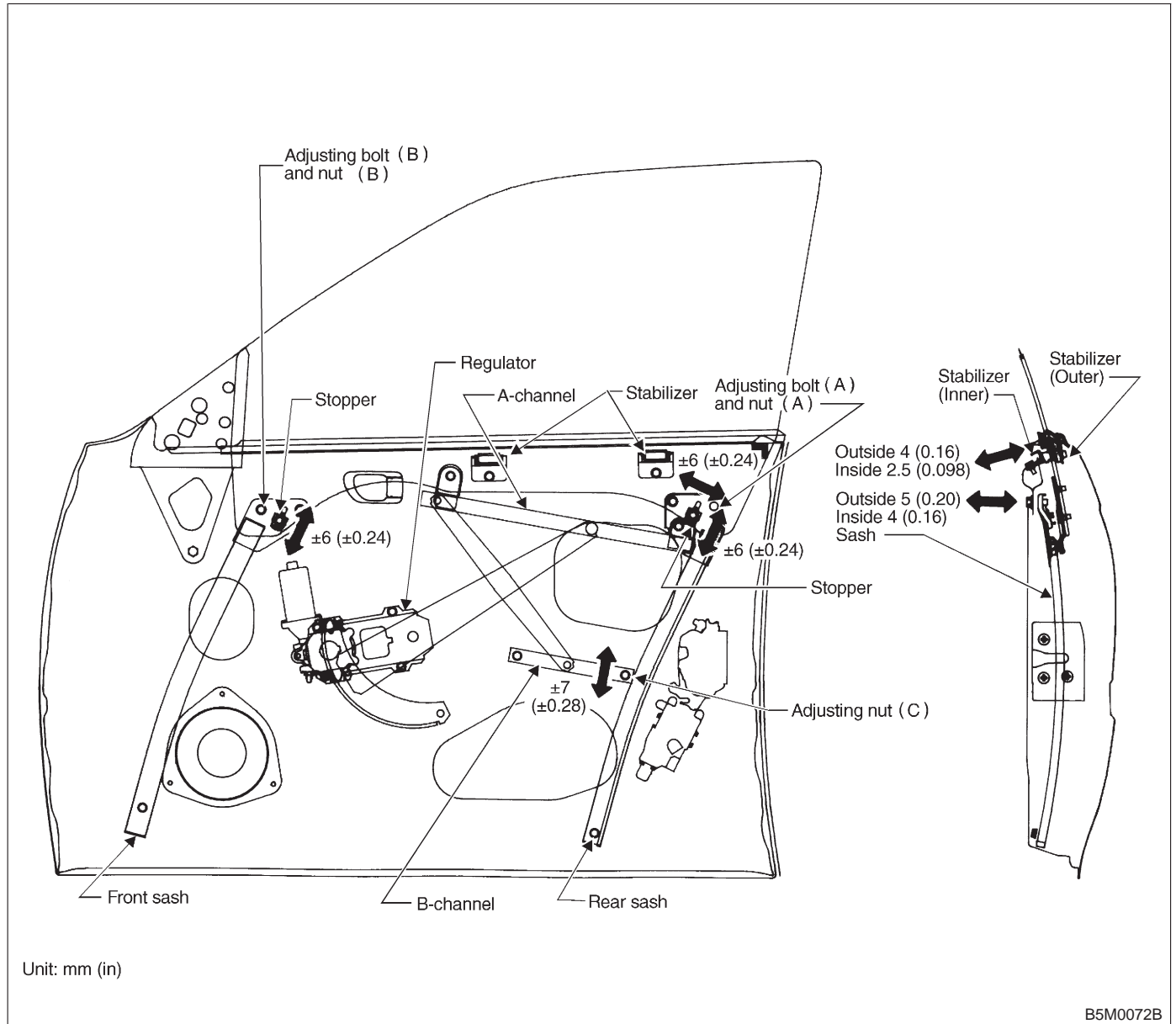

● Door glass fit adjustment

Before adjusting door glass alignment, ensure adjusting bolts for stabilizers, upper stoppers and sashes are loose and glass is raised so that it is in contact with upper and side weatherstrip.

1) Temporarily tighten one of the two rear sash adjusting bolts, at midpoint of oblong hole on inner panel.

2) Temporarily tighten B channel regulator at a position slightly lower than midpoint of oblong hole on inner panel.

3) Lower door glass 10 to 15 mm (0.39 to 0.59 in) from fully closed position. While applying outward pressure (load) to upper edge of glass above mid-point of two outer stabilizers, press inner stabilizer until it just touches the glass, then secure it.

Load: F

Front door glass 39 N (4 kg, 9 lb)

Rear door glass 34.3 N (3.5 kg, 7.7 lb)

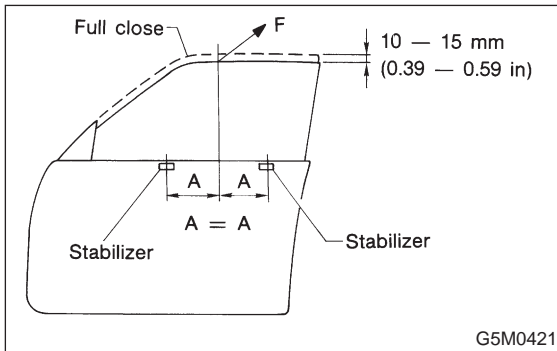

● Remedy for unequal dimensions, between upper, lower and center pillar sides

- 1) Close front door and raise door glass
- 2) Make sure of unequal dimensions.

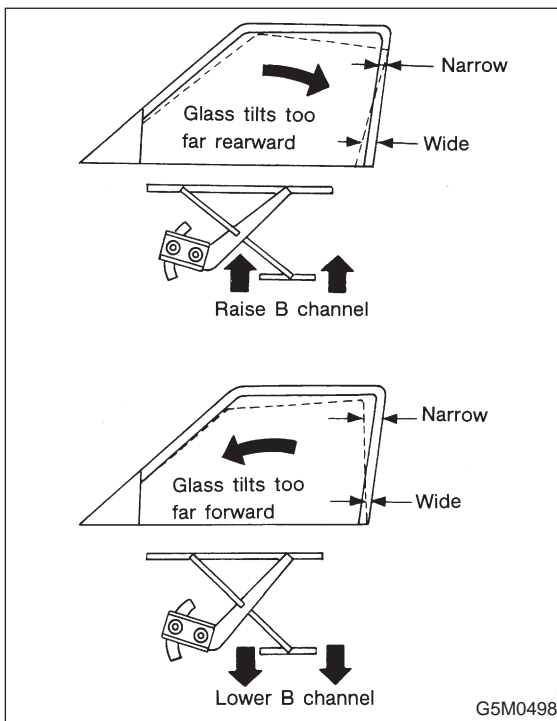

3) If glass tilts to far rearward, loosen adjusting nut (C) and adjust glass to be parallel with center pillar, then after adjustment, tighten adjusting nut (C).

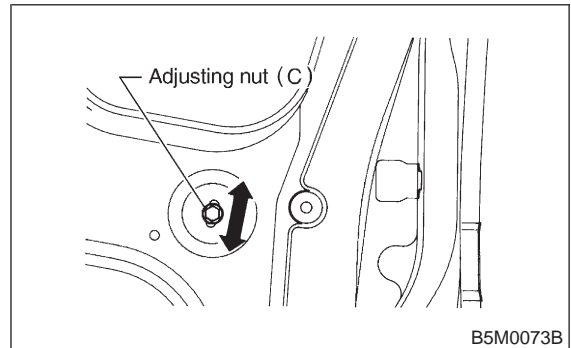

● Remedy for improper glass to center pillar clearance

- 1) Close front door and raise door glass
- 2) Make sure of improper clearance.

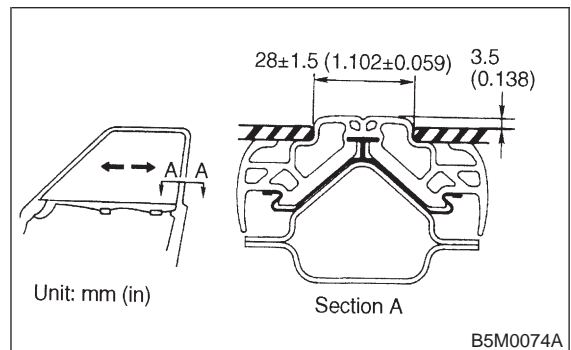

3) If clearance is improper, loosen adjusting nut (A), bolt (A) and adjust glass to center pillar.

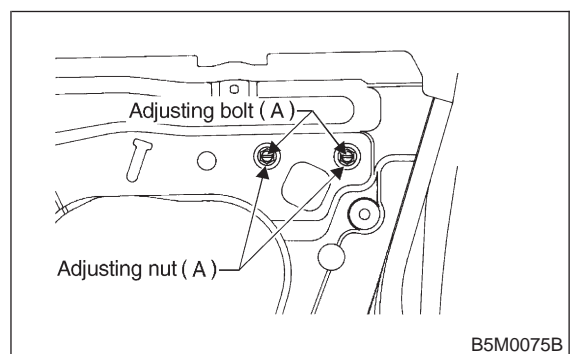

● Remedy for improper upper stop point of door glass

- 1) Loosen front and rear sash stoppers.

2) Increase the upward travel of window glass up to the position where upper edge just touches weatherstrip surface with door closed.

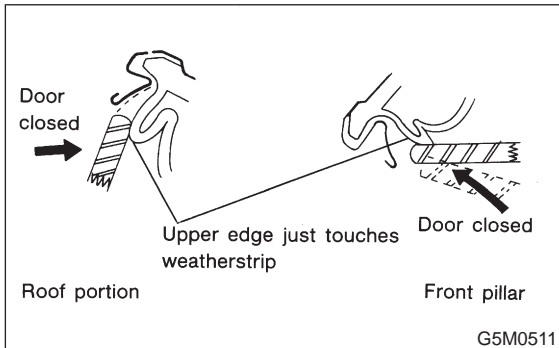

3) After adjustment, temporarily tighten stoppers.

NOTE:

Make sure that each glass stopper is touched.

● **Remedy for incorrect contact of door glass to weatherstrip**

- 1) Close front door and raise door glass.
- 2) If clearance is below specifications, loosen bolt (A) and bolt (B).
- 3) If clearance is over specifications, tighten bolt (A) and bolt (B).

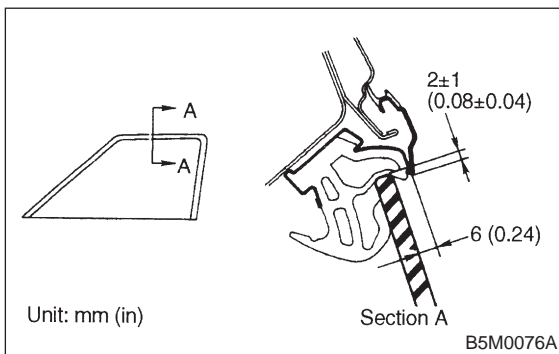

● **Fit adjustment**

Door glass fit is adjusted by displacing the glass front edge with a stabilizer.

NOTE:

Before adjusting glass fit, visually check to determine relative adjusting positions of retainer and molding (on roof side) and glass surface.

1) Alternately adjust two rear sash adjusting bolts (A) until dimensions (indicated in figure) are obtained.

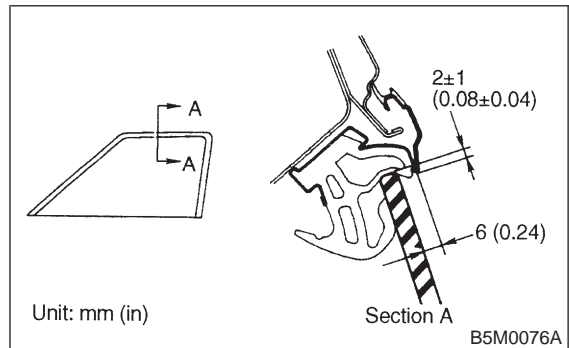

CAUTION:

Do not loosen two adjusting nuts (A) at the same time, as this moves sash fore and aft, creating unequal glass-to-sash clearance. During adjustment, loosen only one nut and keep the other tightened.

NOTE:

Always adjust two rear sash adjusting bolts (A) by the same amount. Do not adjust the adjusting bolts with sash bracket inclined toward inner panel, as this increases effort required to operate regulator.

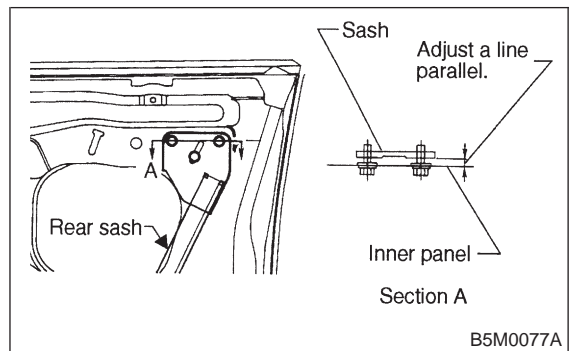

2) Adjust front sash fit using rear sash adjustment procedure outlined above as a guide. Two adjusting bolts must be adjusted by the same amount.

NOTE:

Front and rear sash adjustment procedures are basically the same; however, the amount of adjustment is not always the same due to alignment dispersion of individual doors. Adjust front and rear sash fit, as equally as possible. Otherwise, effort required to operate regulator may increase.

3) After adjusting front sash-to-glass fit, secure front sash.

4. REAR DOOR GLASS

Alignment of rear door glass is basically the same as for the front door glass. Due to slight difference in adjustment dimensions for fore-aft, up-down, and in-out alignments, key points for rear door adjustment are described.

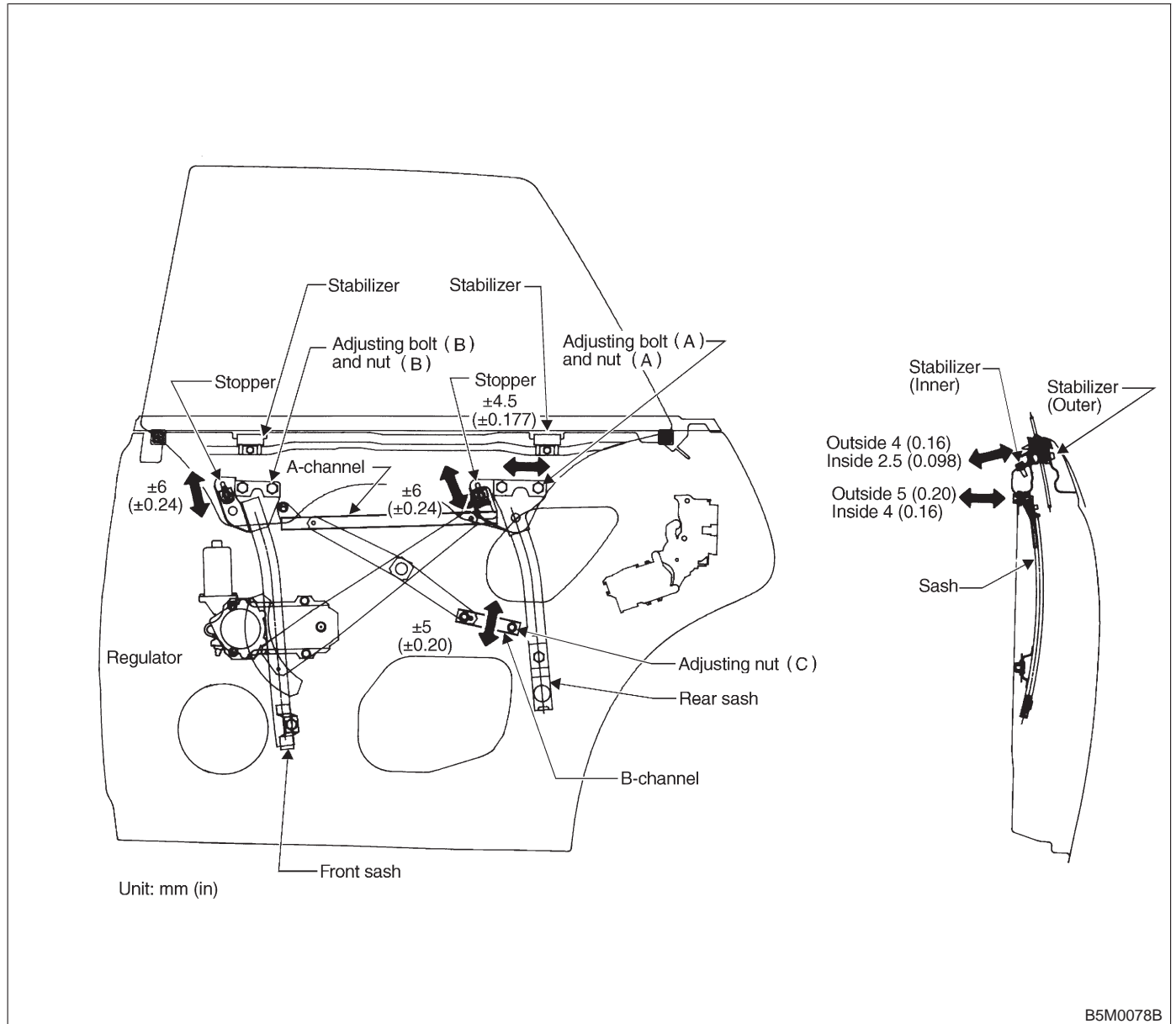

● **Fore-aft adjustment**

1) Door glass alignment must be adjusted so that glass- to-center pillar fit is equal at all points.

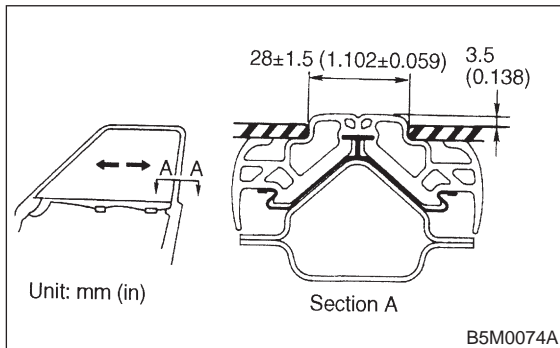

NOTE:

If dimensions are smaller than those indicated, glass will be caught in weatherstrip and may not raise to the fully closed position.

2) After making fore-aft adjustment, raise and lower glass to ensure it is free from any binding.

C: INSPECTION

1. FRONT AND REAR DOOR GLASS

1) Close front door and make sure of all clearances.

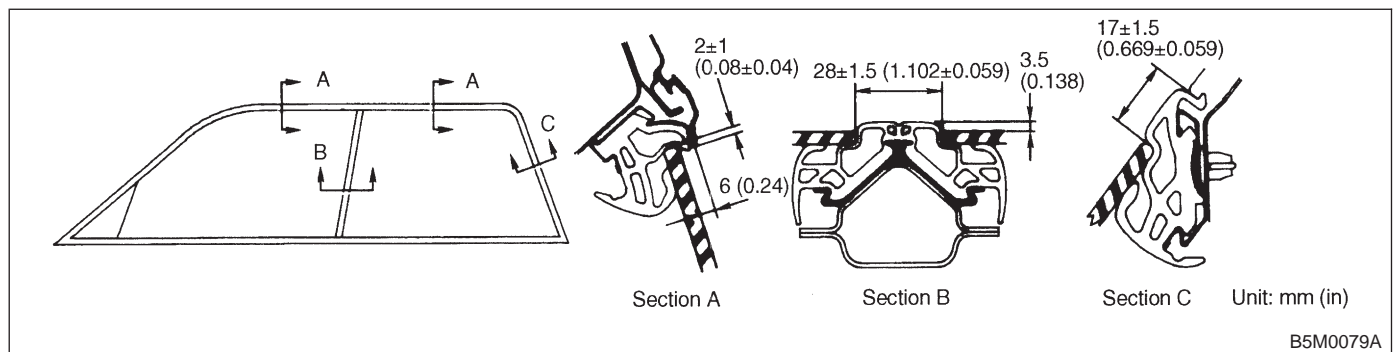

2) If any clearance is not correct, adjust affected parts. Re-check all clearances.

CAUTION:

- Repeatedly adjust parts until all clearances are correct.
- After clearance adjustment, make sure that all adjusting bolts and nuts are tightened.

● **Fit adjustment**

Increasing contact pressure causes rear door glass to be caught in center pillar upper and lower weatherstrip; this will cause premature weatherstrip wear.

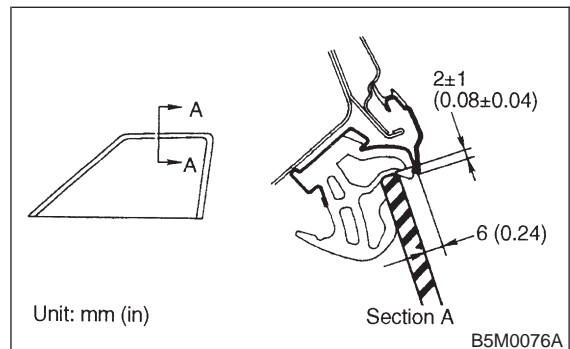

3. Rear Gate

A: REMOVAL AND INSTALLATION

CAUTION:

- Be careful not to scratch coated surfaces of vehicle body and window glass during removal. Place a cloth over the affected area.
- Be careful not to damage trim panels.
- Use an assistant when handling heavy parts.
- Be careful not to damage or lose small parts.