

## 2-5 [T1C10]

# ENGINE COOLING SYSTEM

## 2. Radiator Sub Fan (With A/C model only)

### 1C10 : CHECK HARNESS CONNECTOR BETWEEN MAIN FAN RELAY-2 AND MAIN FAN MOTOR.

Measure resistance of harness between main fan motor connector and main fan relay-2 terminal.

#### Connector & terminal

(F17) No. 3 — (F30) No. 4:

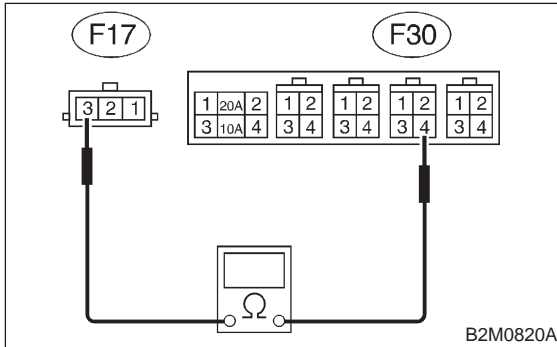

**CHECK** : Is resistance less than 1 Ω?

**YES** : Go to step 1C11.

**NO** : Repair open circuit in harness between main fan motor and main fan relay-2 connector.

### 1C11 : CHECK POOR CONTACT.

Check poor contact in main fan relay-2 connector.  
<Ref. to FOREWORD [T3C1].>

**CHECK** : Is there poor contact in main fan relay-2 connector?

**YES** : Repair poor contact in main fan relay-2 connector.

**NO** : Go to step 1C12.

### 1C12 : CHECK POOR CONTACT.

Check poor contact in main fan motor connector.  
<Ref. to FOREWORD [T3C1].>

**CHECK** : Is there poor contact in main fan motor connector?

**YES** : Repair poor contact in main fan motor connector.

**NO** : Refer to 2-7 "On-Board Diagnostics II System" diagnostics procedure.

## 2. Radiator Sub Fan (With A/C model only)

### A: LO MODE OPERATION

#### DETECTING CONDITION:

##### Condition (1):

- Engine coolant temperature is below 89°C (192°F).
- A/C switch is turned ON.
- Vehicle speed is below 10 km/h (6 MPH).

##### Condition (2):

- Engine coolant temperature is above 95°C (203°F).
- A/C switch is turned OFF.
- Vehicle speed is below 10 km/h (6 MPH).

#### TROUBLE SYMPTOM:

- Radiator sub fan does not rotate at LO speed under conditions (1) and (2) above.

### 2A1 : CHECK POWER SUPPLY TO SUB FAN MOTOR.

#### CAUTION:

Be careful not to overheat engine during repair.

- 1) Turn ignition switch to OFF.
- 2) Disconnect connector from sub fan motor.
- 3) Start the engine, and warm-up it until engine coolant temperature increases over 95°C (203°F).
- 4) Stop the engine and turn ignition switch to ON.
- 5) Turn A/C switch to OFF.
- 6) Measure voltage between sub fan motor connector and chassis ground.

#### Connector & terminal

(F16) No. 2 (+) — Chassis ground (-):

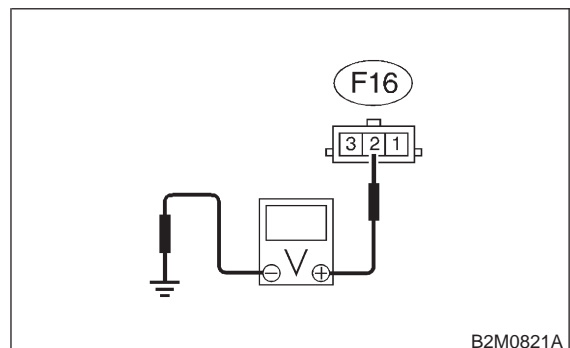

**CHECK** : Is voltage more than 10 V?

**YES** : Go to step 2A2.

**NO** : Go to step 2A5.

## 2A2 : CHECK GROUND CIRCUIT OF SUB FAN MOTOR.

- 1) Turn ignition switch to OFF.
- 2) Measure resistance between sub fan motor connector and chassis ground.

### Connector & terminal

(F16) No. 1 — Chassis ground:

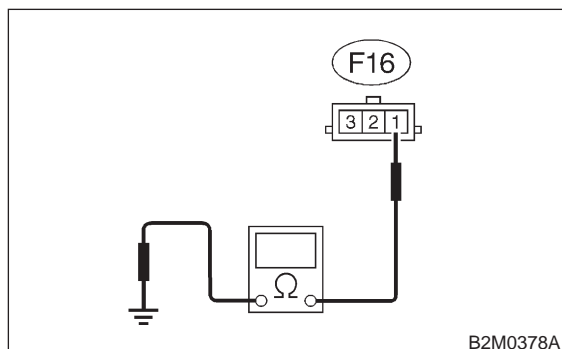

- CHECK** : Is resistance less than 5 Ω?
- YES** : Go to step 2A3.
- NO** : Repair open circuit in harness between sub fan motor connector and chassis ground.

## 2A3 : CHECK POOR CONTACT.

Check poor contact in sub fan motor connector.  
<Ref. to FOREWORD [T3C1].>

- CHECK** : Is there poor contact in sub fan motor connector?
- YES** : Repair poor contact in sub fan motor connector.
- NO** : Go to step 2A4.

## 2A4 : CHECK SUB FAN MOTOR.

Connect battery positive (+) terminal to terminal No. 2 of sub fan motor, and negative (-) terminal to terminal No. 1.

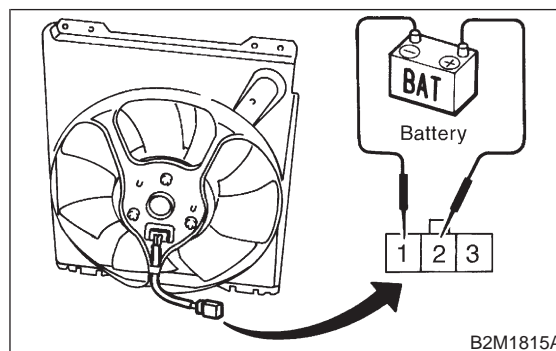

- CHECK** : Does the sub fan rotate at LO speed?
- YES** : Repair poor contact in sub fan motor connector.
- NO** : Replace sub fan motor with a new one.

## 2A5 : CHECK FUSE.

- 1) Turn ignition switch to OFF.
- 2) Remove fuse No. 13 from fuse and relay box.
- 3) Check condition of fuse.

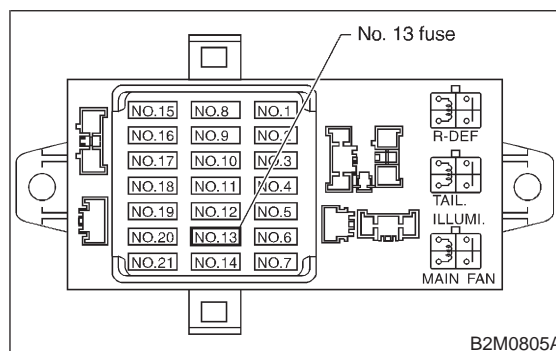

- CHECK** : Is the fuse blown-out?
- YES** : Replace fuse.
- NO** : Go to step 2A6.

## 2-5 [T2A6]

# ENGINE COOLING SYSTEM

## 2. Radiator Sub Fan (With A/C model only)

### 2A6 : CHECK SUB FAN RELAY-1.

- 1) Turn ignition switch to OFF.
- 2) Remove sub fan relay-1 from fuse and relay box.
- 3) Check continuity between sub fan relay-1 terminals.

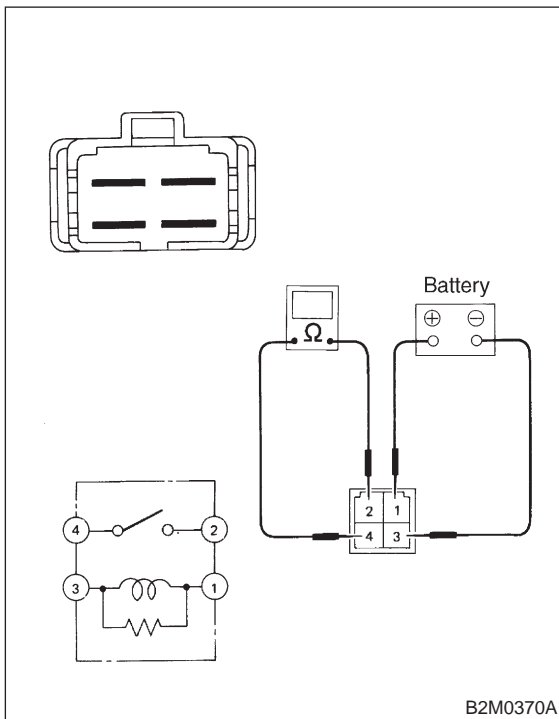

- CHECK** : Does continuity exist between terminals No. 2 and No. 4?
- YES** : Replace sub fan relay-1.
- NO** : Go to step 2A7.

### 2A7 : CHECK SUB FAN RELAY-1.

- 1) Connect battery positive (+) terminal to terminal No. 1 of sub fan relay-1 and negative (-) terminal to terminal No. 3.
- 2) Check continuity between sub fan relay-1 terminals.

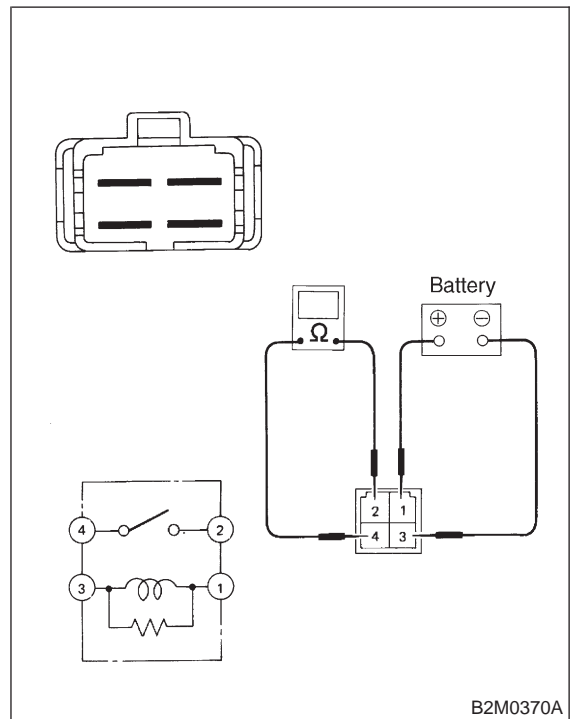

- CHECK** : Does continuity exist between terminals No. 2 and No. 4?
- YES** : Go to step 2A8.
- NO** : Replace sub fan relay-1.

**2A8 : CHECK HARNESS CONNECTOR BETWEEN FUSE AND RELAY BOX AND SUB FAN MOTOR.**

- 1) Turn ignition switch to OFF.
- 2) Disconnect connector from fuse and relay box.
- 3) Measure resistance of harness connector between fuse and relay box and sub fan motor.

**Connector & terminal**

**(F40) No. 3 — (F16) No. 2:**

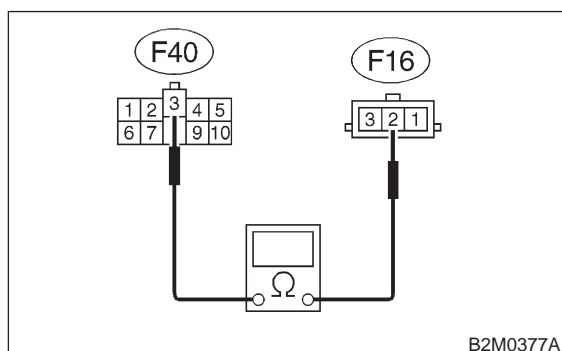

**CHECK** : *Is resistance less than 1 Ω?*

**YES** : Go to step **2A9**.

**NO** : Repair open circuit in harness between fuse and relay box and sub fan motor connector.

**2A9 : CHECK POOR CONTACT.**

Check poor contact in fuse and relay box connector. <Ref. to FOREWORD [T3C1].>

**CHECK** : *Is there poor contact in fuse and relay box connector?*

**YES** : Repair poor contact in fuse and relay box connector.

**NO** : Go to step **2A10**.

**2A10 : CHECK POOR CONTACT.**

Check poor contact in sub fan motor connector. <Ref. to FOREWORD [T3C1].>

**CHECK** : *Is there poor contact in sub fan motor connector?*

**YES** : Repair poor contact in sub fan motor connector.

**NO** : Refer to 2-7 “On-Board Diagnostics II System” diagnostics procedure.

**B: HI MODE OPERATION**

**DETECTING CONDITION:**

**Condition (1):**

- Engine coolant temperature is below 89°C (192°F).
- A/C switch is turned ON.
- Vehicle speed is over 20 km/h (12 MPH).

**Condition (2):**

- Engine coolant temperature is above 95°C (203°F).
- A/C switch is turned OFF.
- Vehicle speed is over 20 km/h (12 MPH).

**Condition (3):**

- Engine coolant temperature is above 95°C (203°F).
- A/C switch is turned ON.

**TROUBLE SYMPTOM:**

- Radiator sub fan does not rotate at HI speed under conditions (1), (2) and (3) above.

**2B1 : CHECK OPERATION OF SUB FAN MOTOR LO MODE.**

**CAUTION:**

**Be careful not to overheat engine during repair.**

- 1) Start the engine, and warm-up it until engine coolant temperature increases over 95°C (203°F).
- 2) Stop the engine and turn ignition switch to ON.
- 3) Turn A/C switch to OFF.

**CHECK** : *Does the sub fan operate at LO MODE?*

**YES** : Go to step **2B2**.

**NO** : Go to LO MODE OPERATION diagnostics chart. <Ref. to 2-5 [T2A0].>

## 2-5 [T2B2]

# ENGINE COOLING SYSTEM

### 2. Radiator Sub Fan (With A/C model only)

#### 2B2 : CHECK POWER SUPPLY TO SUB FAN MOTOR.

##### CAUTION:

**Be careful not to overheat engine during repair.**

- 1) Turn ignition switch to OFF.
- 2) Disconnect connector from sub fan motor.
- 3) Start the engine, and warm-up it until engine coolant temperature increases over 95°C (203°F).
- 4) Stop the engine and turn ignition switch to ON.
- 5) Turn A/C switch to ON.
- 6) Measure voltage between sub fan motor connector and chassis ground.

##### Connector & terminal

**(F16) No. 3 (+) — Chassis ground (-):**

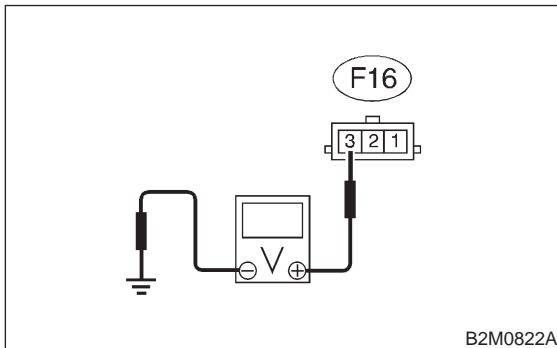

**CHECK** : *Is voltage more than 10 V?*

**YES** : Go to step 2B3.

**NO** : Go to step 2B4.

#### 2B3 : CHECK SUB FAN MOTOR.

- 1) Turn ignition switch and A/C switch to OFF.
- 2) Connect battery positive (+) terminal to terminals No. 2 and No. 3 of sub fan motor connector, and negative (-) terminal to terminal No. 1.

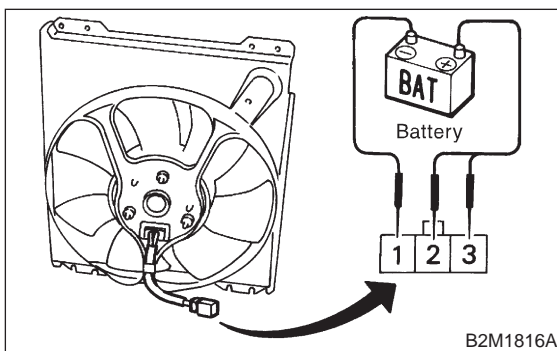

**CHECK** : *Does the sub fan rotate at HI speed?*

**YES** : Repair poor contact in sub fan motor connector.

**NO** : Replace sub fan motor with a new one.

#### 2B4 : CHECK POWER SUPPLY TO SUB FAN RELAY-2.

- 1) Turn ignition switch and A/C switch to OFF.
- 2) Remove sub fan relay-2 from A/C relay holder.
- 3) Turn ignition switch to ON.
- 4) Measure voltage between sub fan relay-2 terminal and chassis ground.

##### Connector & terminal

**(F29) No. 2 (+) — Chassis ground (-):**

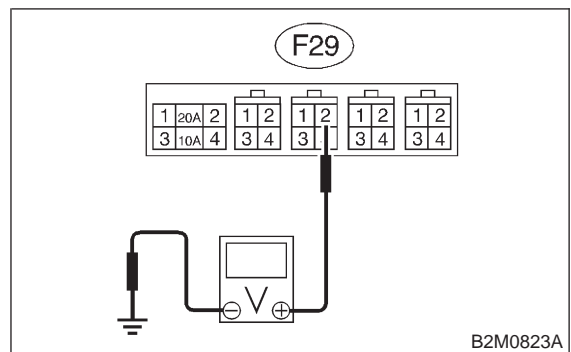

**CHECK** : *Is voltage more than 10 V?*

**YES** : Go to step 2B5.

**NO** : Go to step 2B6.

#### 2B5 : CHECK POWER SUPPLY TO SUB FAN RELAY-2.

Measure voltage between sub fan relay-2 connector and chassis ground.

##### Connector & terminal

**(F29) No. 1 (+) — Chassis ground (-):**

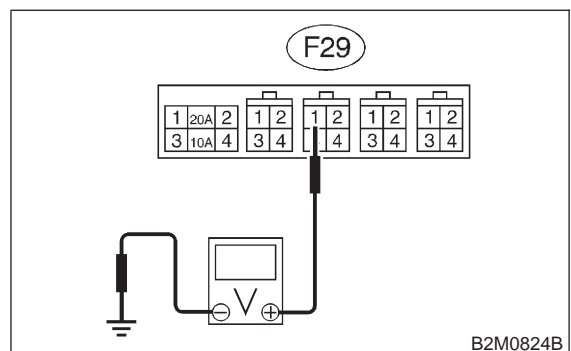

**CHECK** : *Is voltage more than 10 V?*

**YES** : Go to step 2B9.

**NO** : Go to step 2B7.

**2B6 : CHECK HARNESS CONNECTOR BETWEEN FUSE AND RELAY BOX AND A/C RELAY HOLDER SUB FAN RELAY-2.**

- 1) Turn ignition switch to OFF.
- 2) Disconnect connector from fuse and relay box.
- 3) Measure resistance of harness between fuse and relay box connector and A/C relay holder sub fan relay-2 terminal.

**Connector & terminal**  
(F40) No. 3 — (F29) No. 2:

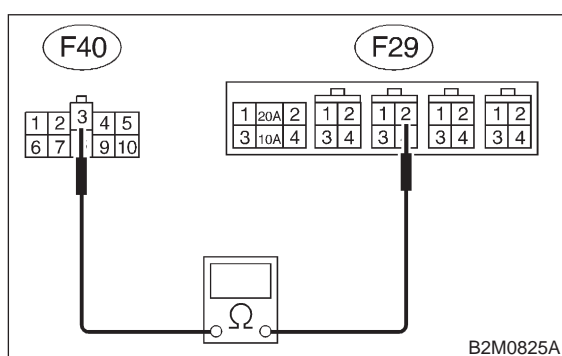

- CHECK** : *Is resistance less than 1 Ω?*
- YES** : Repair poor contact in sub fan relay-2 connector.
- NO** : Repair open circuit in harness between fuse and relay box connector and sub fan relay-2 terminal.

**2B7 : CHECK OPERATION OF MAIN FAN MOTOR LO MODE.**

- 1) Turn ignition switch to OFF.
- 2) Install sub fan relay-2 on A/C relay holder, and connect sub fan motor connector.

**CAUTION:**

**Be careful not to overheat engine during repair.**

- 3) Start the engine, and warm-up it until engine coolant temperature increases over 95°C (203°F).
- 4) Stop the engine and turn ignition switch to ON.
- 5) Turn A/C switch to OFF.

- CHECK** : *Does the main fan operate at LO MODE?*
- YES** : Go to step 2B8.
- NO** : Go to LO MODE OPERATION diagnostics chart. <Ref. to 2-5 [T1B0].>

**2B8 : CHECK HARNESS CONNECTOR BETWEEN 10 A FUSE AND SUB FAN RELAY-2 IN A/C RELAY HOLDER.**

- 1) Turn ignition switch to ON.
- 2) Remove 10 A fuse from A/C relay holder.
- 3) Remove sub fan relay-2 from A/C relay holder.
- 4) Measure resistance of harness between 10 A fuse and sub fan relay-2 terminal.

**Connector & terminal**  
(F27) No. 4 — (F29) No. 1:

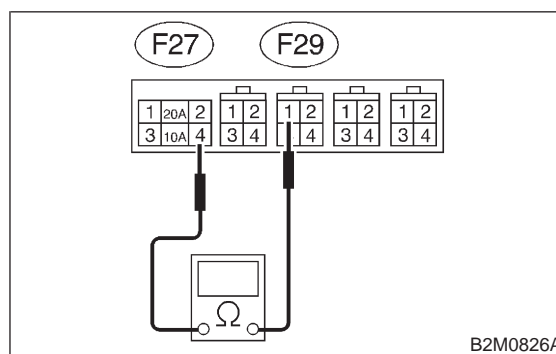

- CHECK** : *Is resistance less than 1 Ω?*
- YES** : Repair poor contact in sub fan relay-2 connector.
- NO** : Repair open circuit in harness between 10 A fuse and sub fan relay-2 connector.

## 2-5 [T2B9]

# ENGINE COOLING SYSTEM

## 2. Radiator Sub Fan (With A/C model only)

### 2B9 : CHECK SUB FAN RELAY-2.

- 1) Turn ignition switch to OFF.
- 2) Check continuity between sub fan relay-2 terminals.

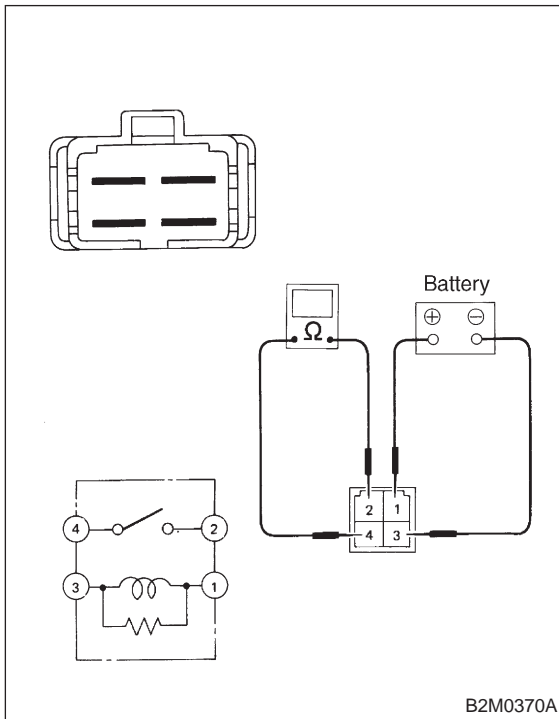

**CHECK** : Does continuity exist between terminals No. 2 and No. 4?

**YES** : Replace sub fan relay-2.

**NO** : Go to step 2B10.

### 2B10 : CHECK SUB FAN RELAY-2.

- 1) Connect battery to terminals No. 1 and No. 3 of sub fan relay-2.
- 2) Check continuity between sub fan relay-2 terminals.

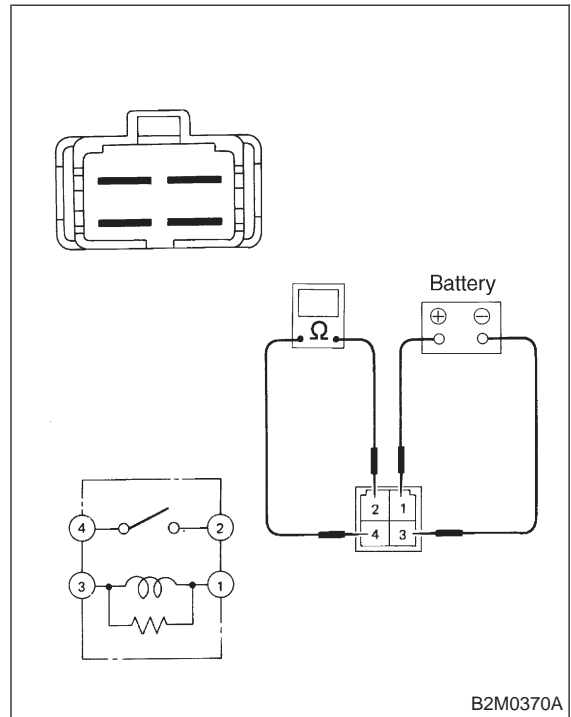

**CHECK** : Does continuity exist between terminals No. 2 and No. 4?

**YES** : Go to step 2B11.

**NO** : Replace sub fan relay-2.

**2B11 : CHECK HARNESS CONNECTOR BETWEEN SUB FAN RELAY-2 AND SUB FAN MOTOR.**

Measure resistance of harness between sub fan motor connector and sub fan relay-2 terminal.

**Connector & terminal**

**(F16) No. 3 — (F29) No. 4:**

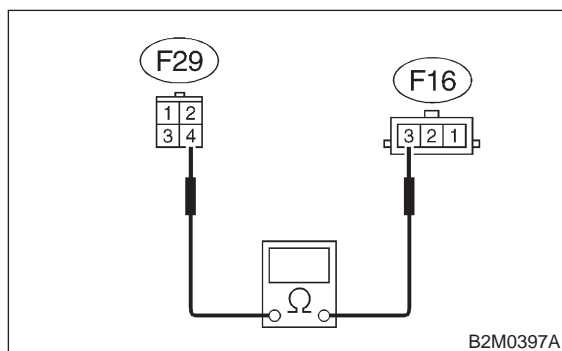

- CHECK** : **Is resistance less than 1 Ω?**
- YES** : Go to step **2B12**.
- NO** : Repair open circuit in harness between sub fan motor and sub fan relay-2 connector.

**2B12 : CHECK POOR CONTACT.**

Check poor contact in sub fan relay-2 connector. <Ref. to FOREWORD [T3C1].>

- CHECK** : **Is there poor contact in sub fan relay-2 connector?**
- YES** : Repair poor contact in sub fan relay-2 connector.
- NO** : Go to step **2B13**.

**2B13 : CHECK POOR CONTACT.**

Check poor contact in sub fan motor connector. <Ref. to FOREWORD [T3C1].>

- CHECK** : **Is there poor contact in sub fan motor connector?**
- YES** : Repair poor contact in sub fan motor connector.
- NO** : Refer to 2-7 “On-Board Diagnostics II System” diagnostics procedure.



MEMO: