

1. Engine

A: GENERAL PRECAUTION

- (1) Remove or install engine in an area where chain hoists, lifting devices, etc. are available for ready use.
- (2) Be sure not to damage coated surfaces of body panels with tools or stain seats and windows with coolant or oil. Place a cover over fenders, as required, for protection.
- (3) Prior to starting work, prepare the following: Service tools, clean cloth, containers to catch coolant and oil, wire ropes, chain hoist, transmission jacks, etc.
- (4) Lift-up or lower the vehicle when necessary. Make sure to support the correct positions. <Ref. to 1-3 [G700].>

B: REMOVAL

- 1) Set the vehicle on lift arms.
- 2) Open front hood and support with a stay.
- 3) Release fuel pressure.
 - (1) Disconnect fuel tank connector.

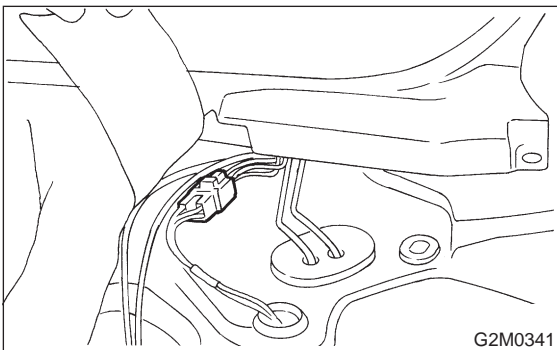

- (2) Start the engine, and run until it stalls.
- (3) After the engine stalls, crank it for five seconds more.
- (4) Turn ignition switch to "OFF". <Ref. to 2-8 [W1B0].>
- 4) Disconnect battery cables and remove battery from vehicle.

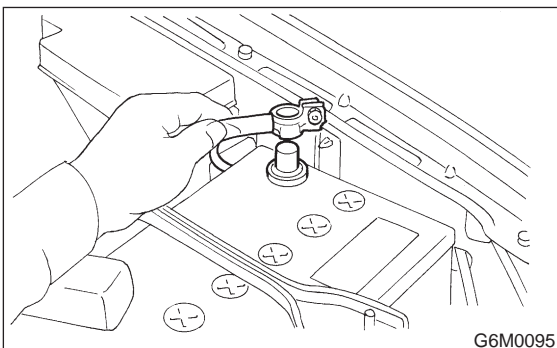

- 5) Drain coolant
Set container under the vehicle, and remove drain cock from radiator.

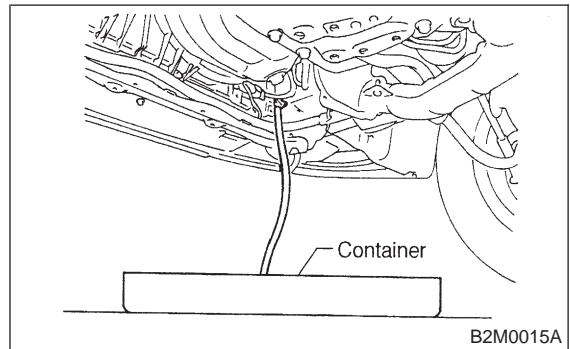

- 6) Remove cooling system.
 - (1) Disconnect radiator fan motor connector.
 - (2) Disconnect radiator outlet hose from thermostat cover.

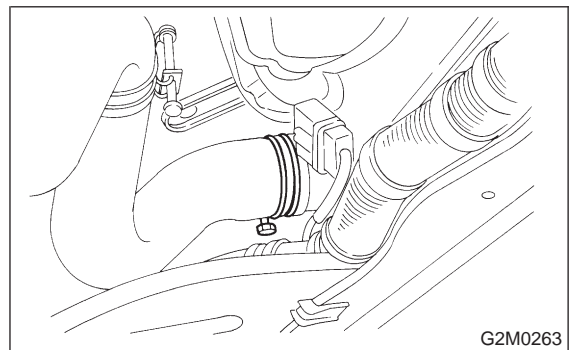

- (3) Disconnect ATF cooler hoses from pipes. (AT vehicles)

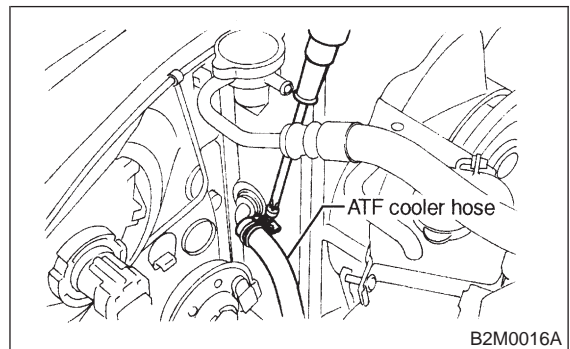

- (4) Remove V-belt cover.

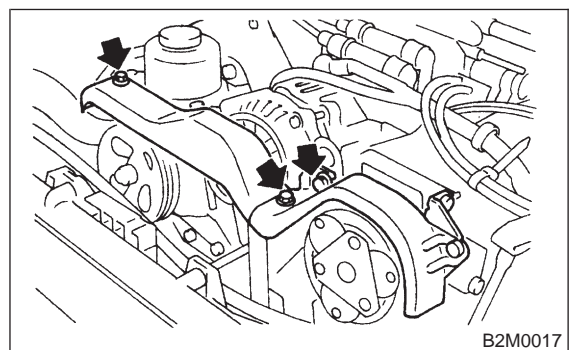

1. Engine

(5) Disconnect radiator inlet hose from radiator.

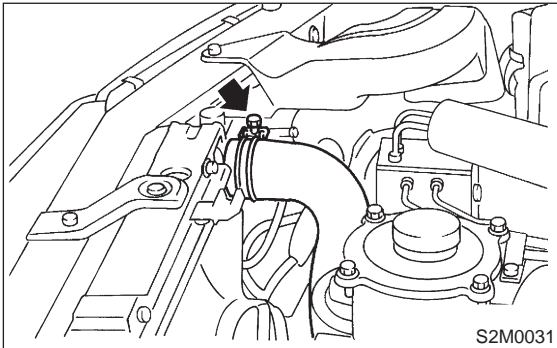

(6) Remove radiator upper bracket, and remove radiator assembly from vehicle.

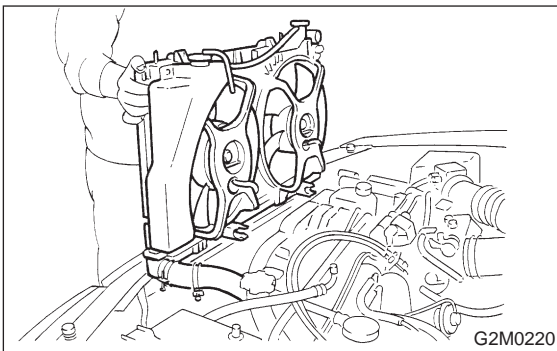

7) Collect refrigerant, and remove pressure hoses. (With A/C)

- (1) Place and connect the attachment hose to the refrigerant recycle system.
- (2) Collect refrigerant from A/C system.
- (3) Disconnect A/C flexible hoses from A/C compressor.

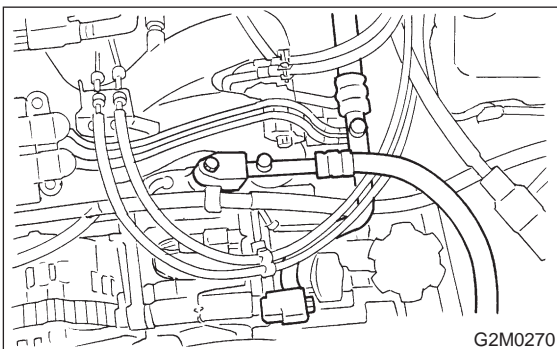

8) Remove air intake system.
 (1) Disconnect connector from mass air flow sensor.

(2) Remove air intake duct with air cleaner upper cover, and remove air cleaner element.

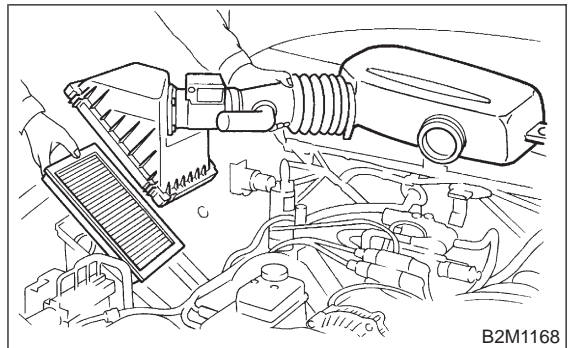

9) Remove canister and bracket. (2200 cc FWD and Taiwan spec. vehicles)

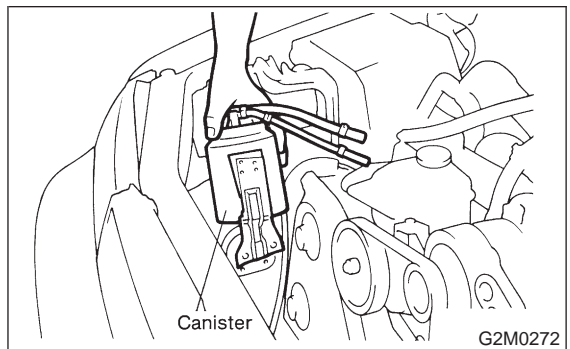

10) Remove chamber stay.
 ● MT vehicles

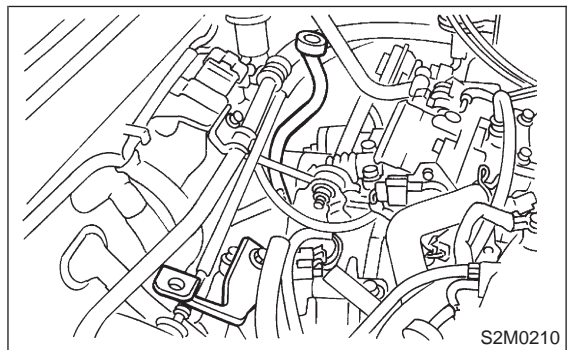

● AT vehicles

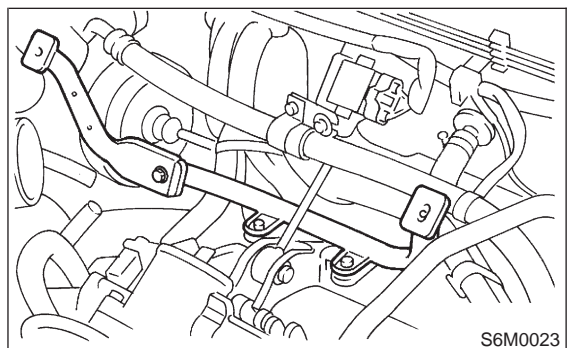

11) Disconnect connectors, cables and hoses.

(1) Disconnect the following connectors.

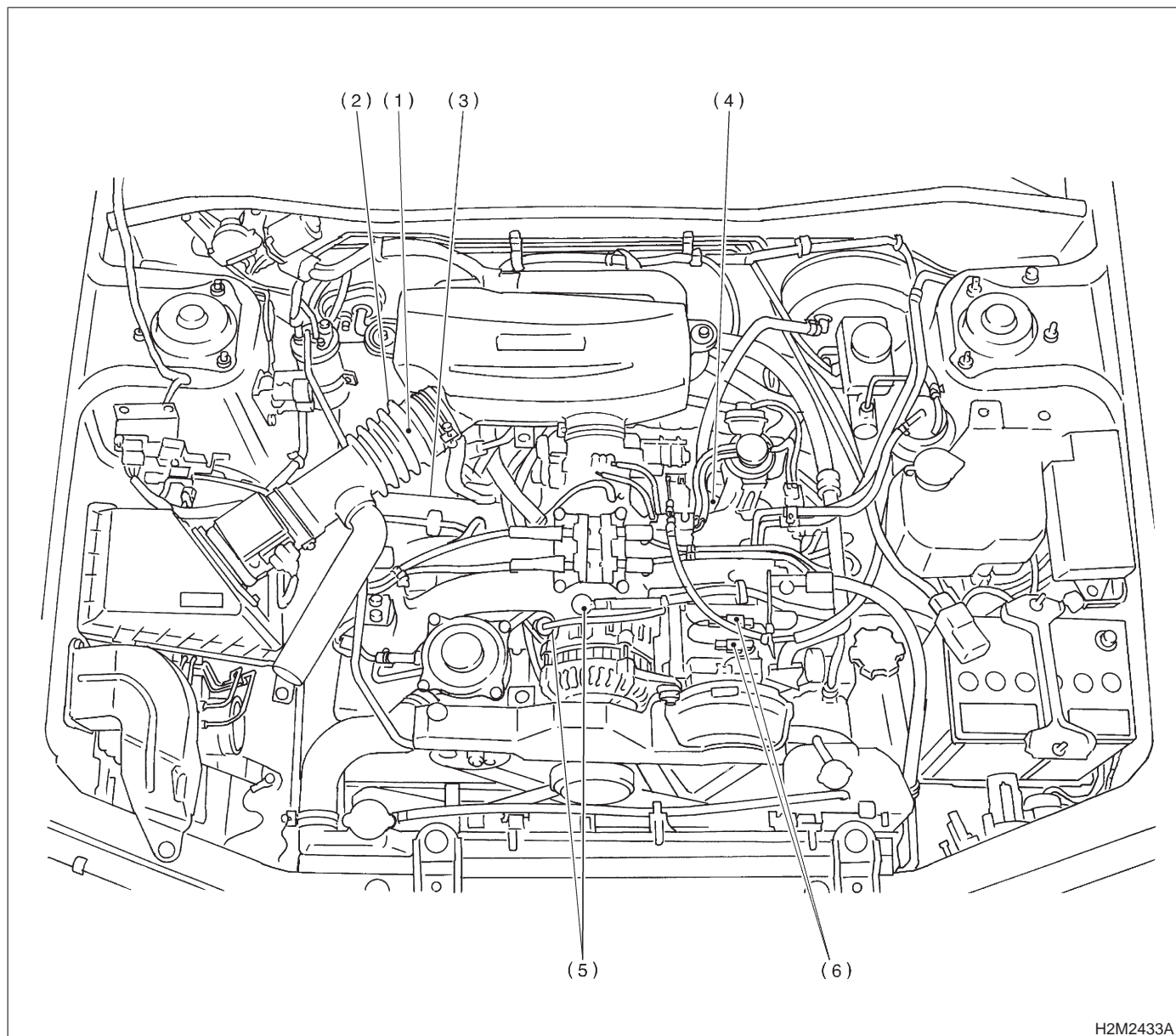

H2M2433A

- (1) Front oxygen sensor connector
- (2) Rear oxygen sensor connector
(California spec. vehicles)
- (3) Engine harness connectors
- (4) Engine ground terminal
- (5) Alternator connector and terminal
- (6) A/C compressor connectors
(With A/C)

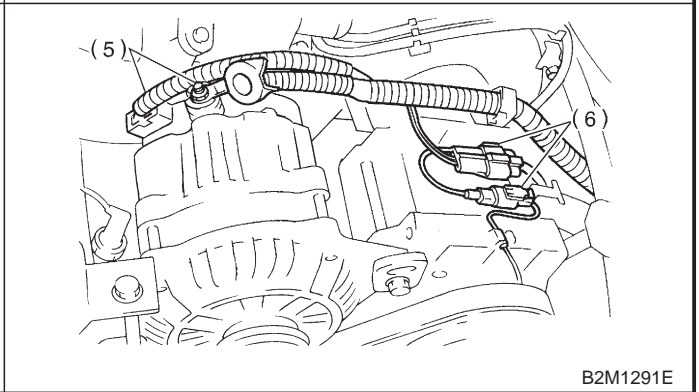
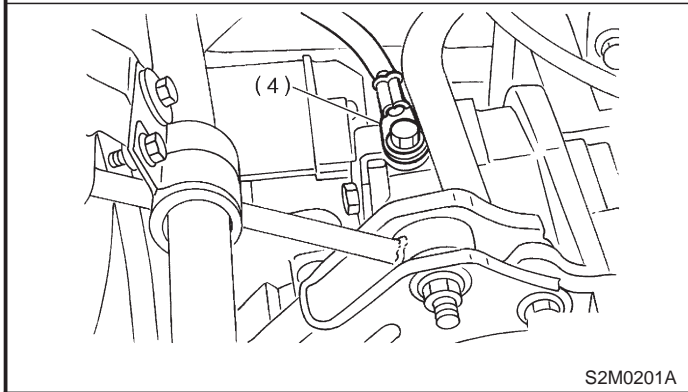
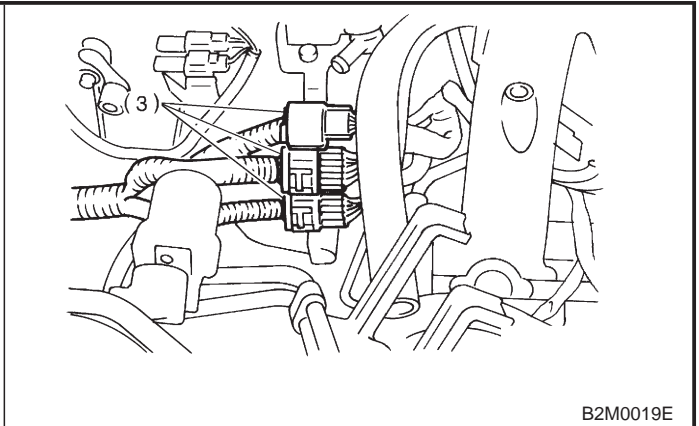
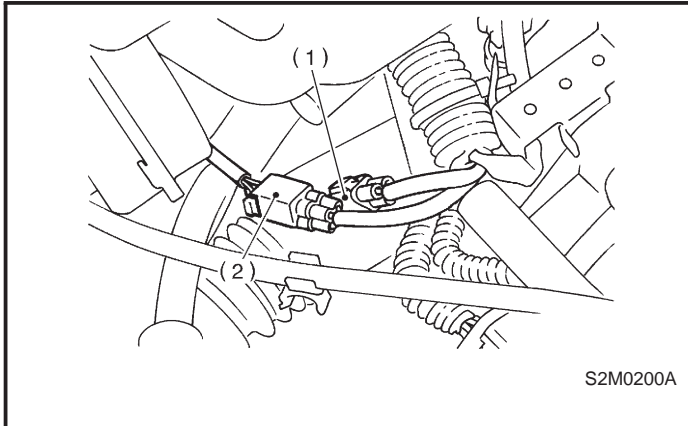

(2) Disconnect the following cables.

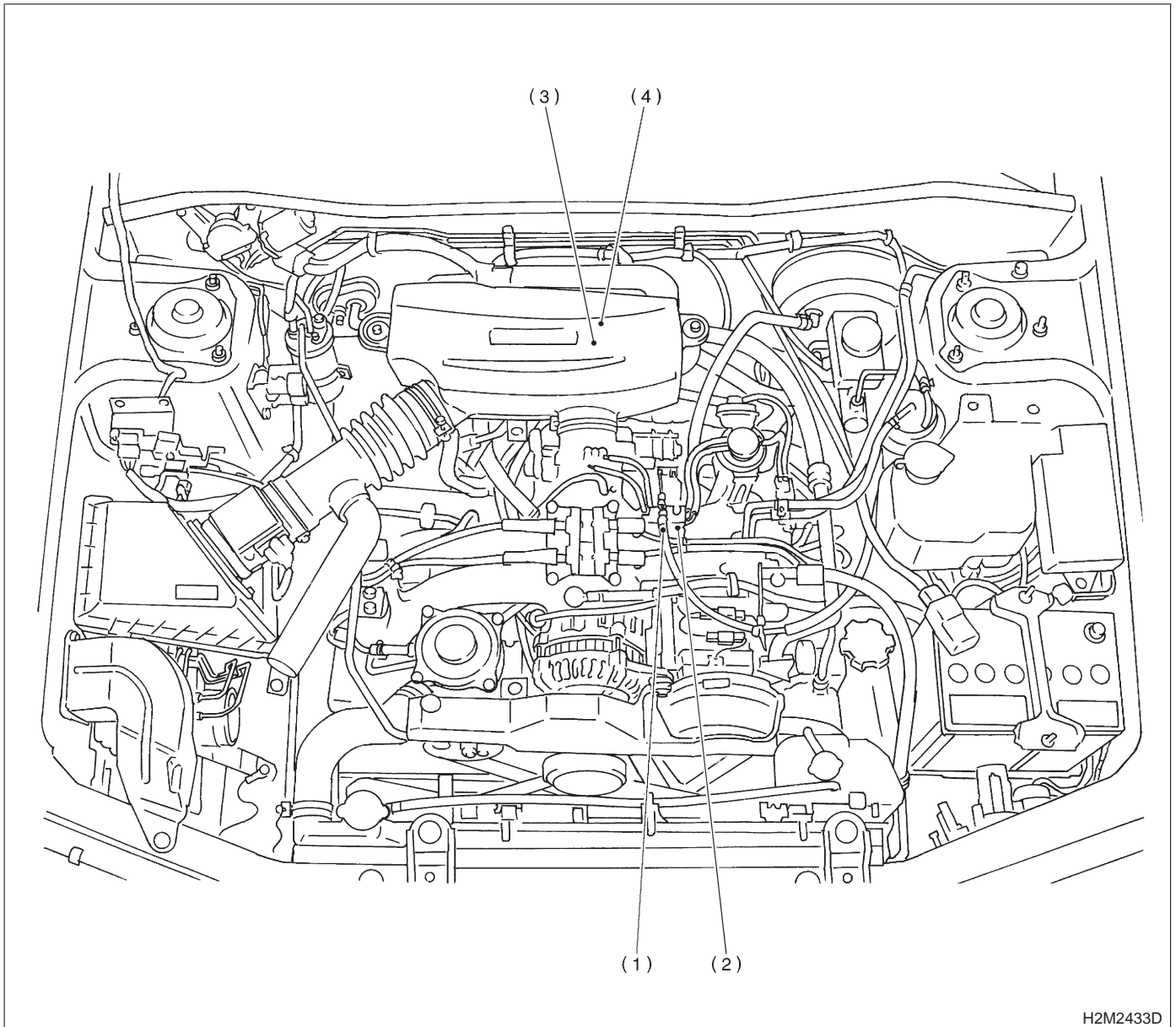

H2M2433D

- (1) Accelerator cable
- (2) Cruise control cable (With cruise control vehicles)
- (3) Clutch return spring (Without hill holder vehicles)
- (4) Clutch cable (2200 cc MT vehicles)

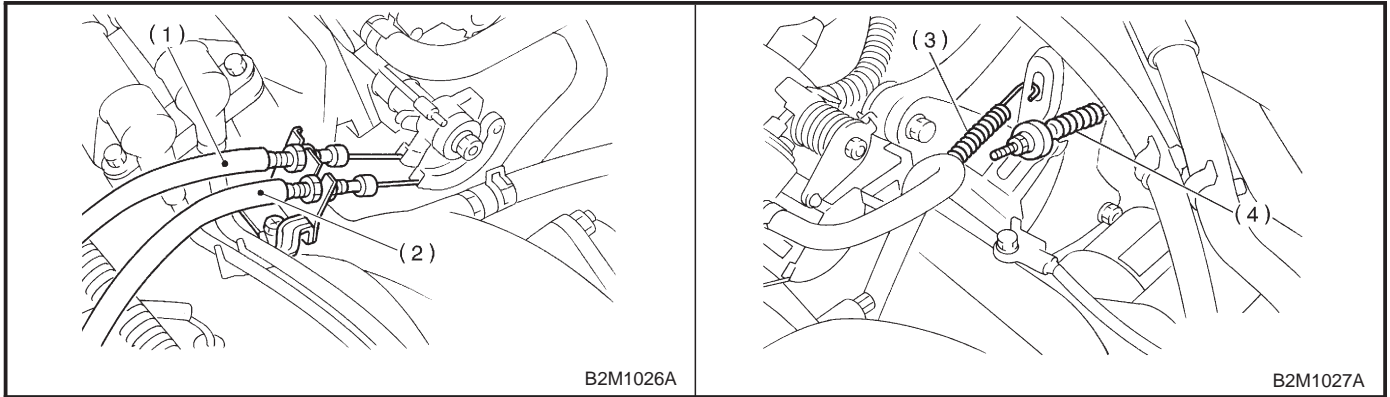

(3) Disconnect the following hoses.

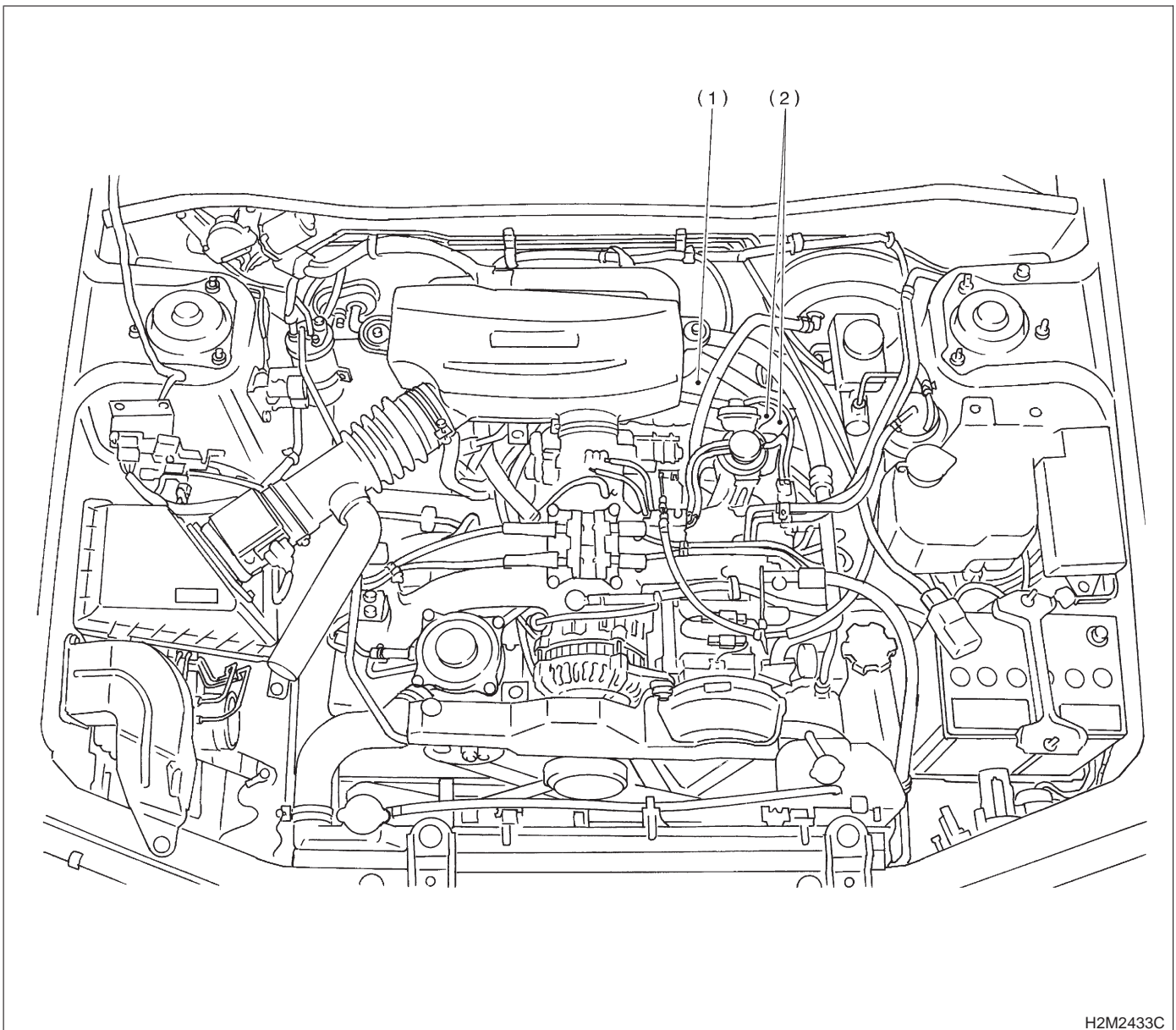

- (1) Brake booster vacuum hose
- (2) Heater inlet and outlet hose

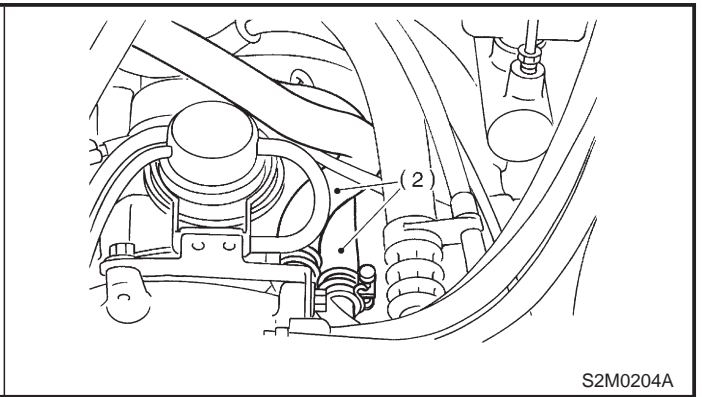
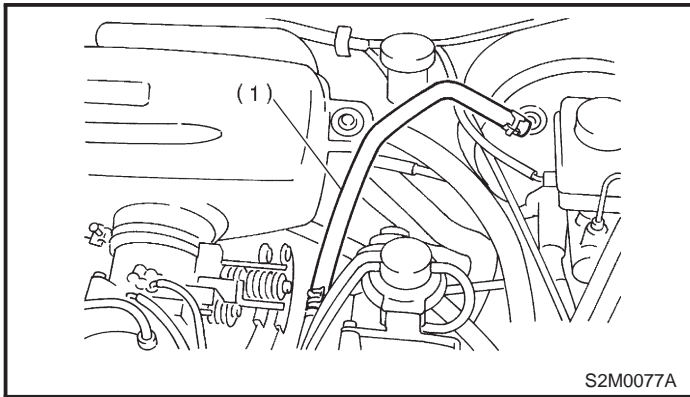

12) Remove power steering pump from bracket.
 (1) Loosen lock bolt and slider bolt, and remove front side V-belt.

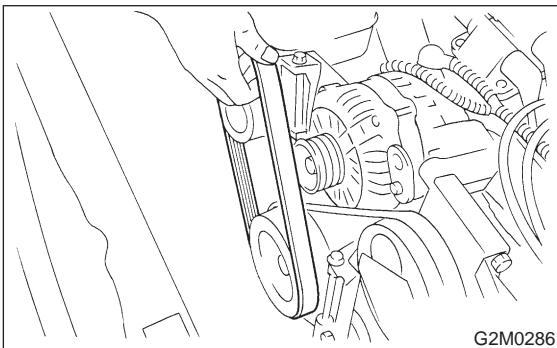

(2) Remove pipe with bracket from intake manifold.

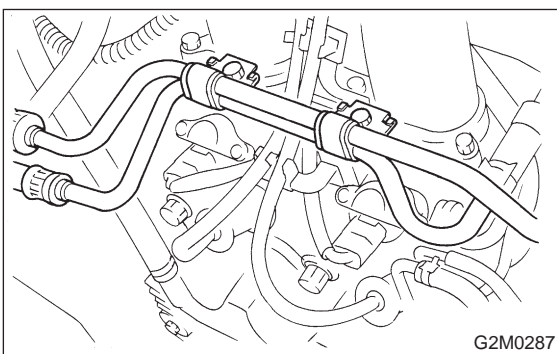

(3) Remove bolts which install power steering pump from bracket.

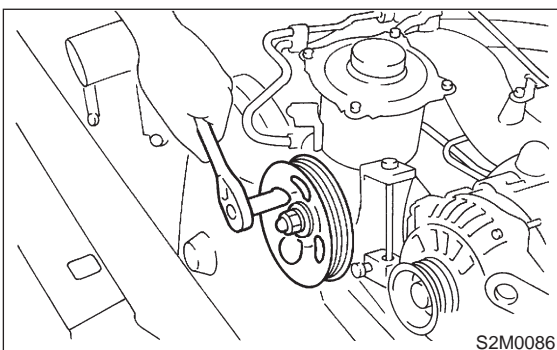

(4) Place power steering pump on the right side wheel apron.

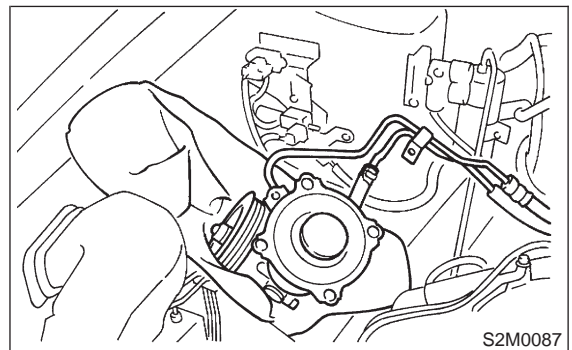

13) Remove front exhaust pipe and center exhaust pipe.

(1) Lift-up the vehicle.
 (2) Remove nuts which install front exhaust pipe onto engine.

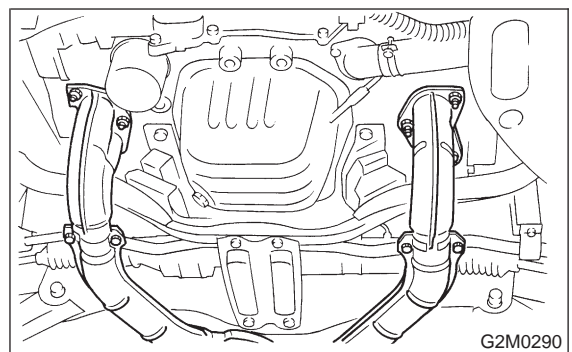

(3) Disconnect connector from rear oxygen sensor. (Except California spec. vehicles)

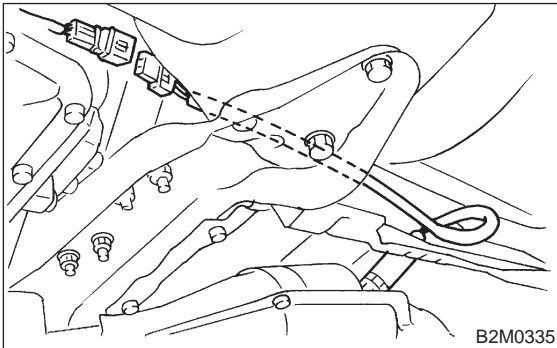

(4) Separate center exhaust pipe from rear exhaust pipe.

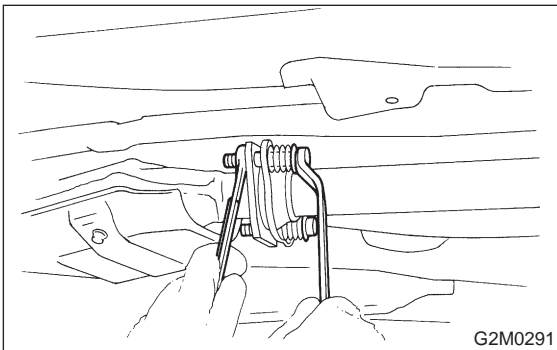

(5) Remove bolt which installs center exhaust pipe on hunger bracket.

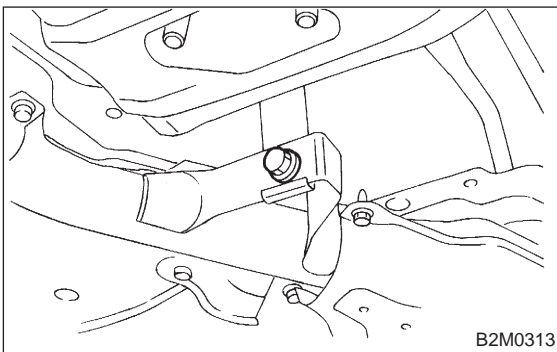

(6) Take off front and center exhaust pipes.

CAUTION:

Exhaust pipe will drop when all bolts are removed. So, hold it when removing the last bolt.

14) Remove nuts which hold lower side of transmission to engine.

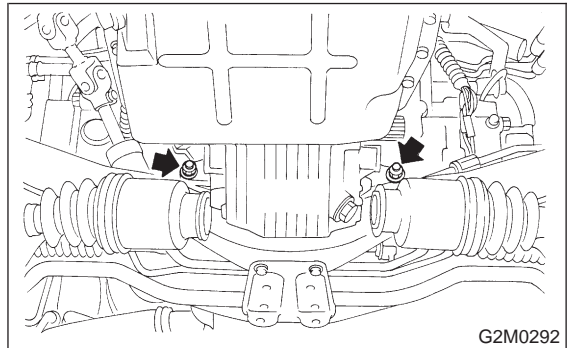

15) Remove nuts which install front cushion rubber onto front crossmember.

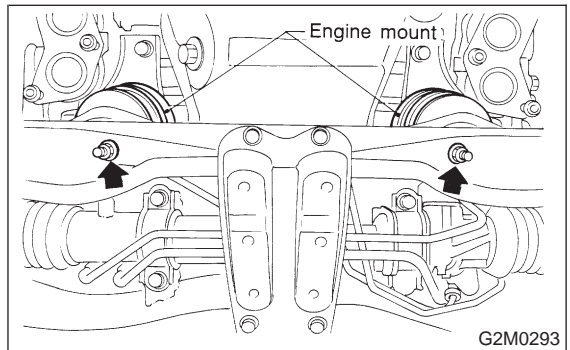

16) Separate torque converter from drive plate. (AT vehicles)

- (1) Lower the vehicle.
- (2) Remove service hole plug.
- (3) Remove bolts which hold torque converter to drive plate.

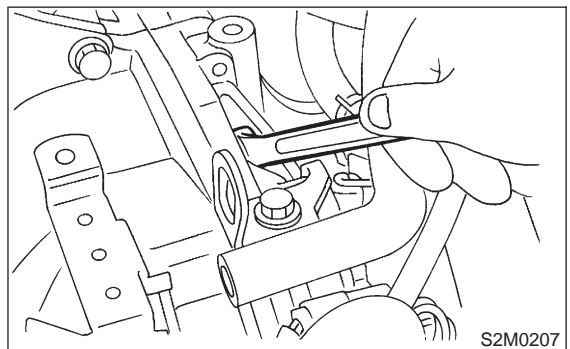

(4) Remove other bolts while rotating the engine using ST.
ST 499977000 CRANK PULLEY WRENCH

17) Remove pitching stopper.

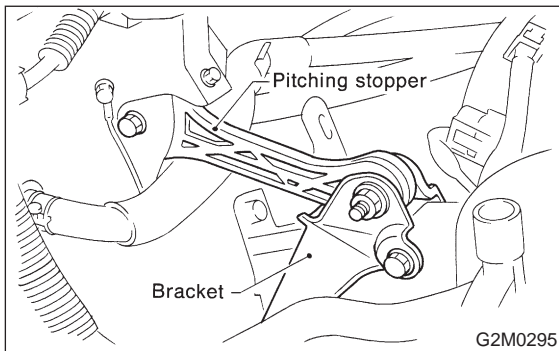

18) Disconnect fuel delivery hose, return hose and evaporation hose.

CAUTION:

- Disconnect hose with its end wrapped with cloth to prevent fuel from splashing.
- Catch fuel from hose into container.

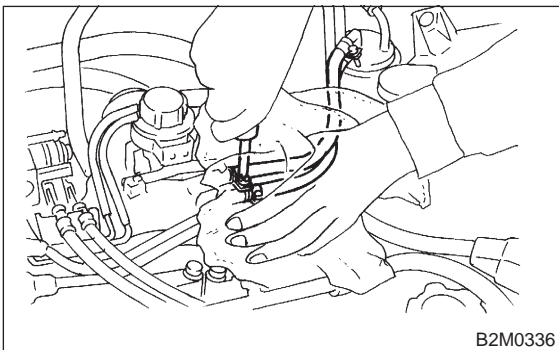

19) Support engine with a lifting device and wire ropes.

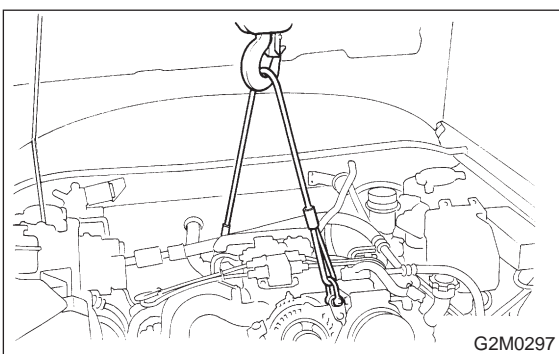

20) Support transmission with a garage jack.

CAUTION:

Before moving engine away from transmission, check to be sure no work has been overlooked. Doing this is very important in order to facilitate re-installation and because transmission lowers under its own weight.

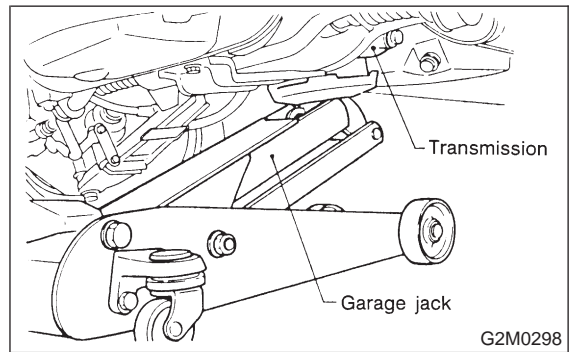

21) Remove bolts which hold upper side of transmission to engine.

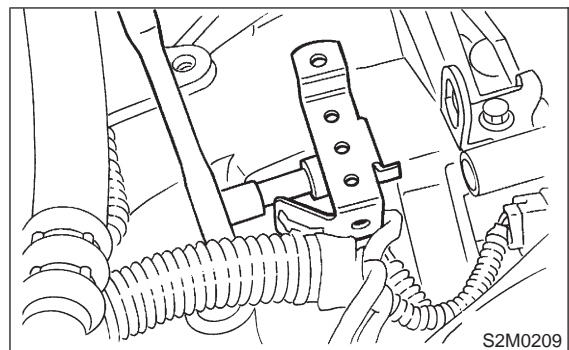

22) Remove engine from vehicle

- (1) Slightly raise engine.
- (2) Raise transmission with garage jack.
- (3) Move engine horizontally until mainshaft is withdrawn from clutch cover.
- (4) Slowly move engine away from engine compartment.

CAUTION:

Be careful not to damage adjacent parts or body panels with crank pulley, oil pressure gauge, etc.

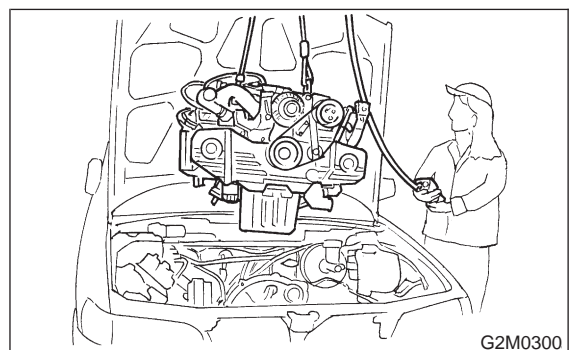

C: INSTALLATION

- 1) Install engine onto transmission.
 - (1) Position engine in engine compartment and align it with transmission.

CAUTION:

Be careful not to damage adjacent parts or body panels with crank pulley, oil pressure gauge, etc.

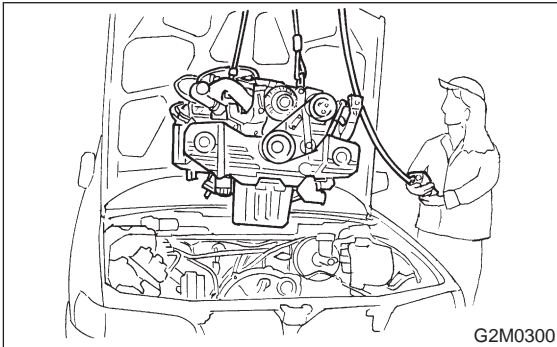

- (2) Apply a small amount of grease to spline of mainshaft.
- 2) Tighten bolts which hold upper side of transmission to engine.

Tightening torque:
 $50 \pm 4 \text{ N-m (} 5.1 \pm 0.4 \text{ kg-m, } 36.9 \pm 2.9 \text{ ft-lb)}$

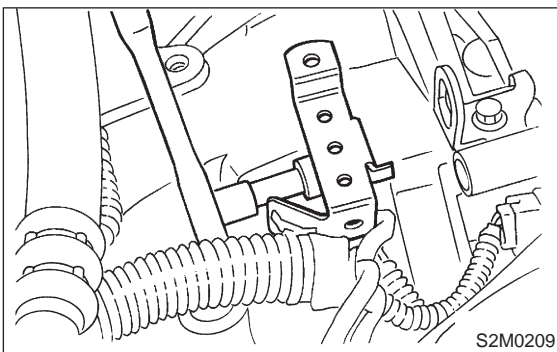

- 3) Remove lifting device and wire ropes.

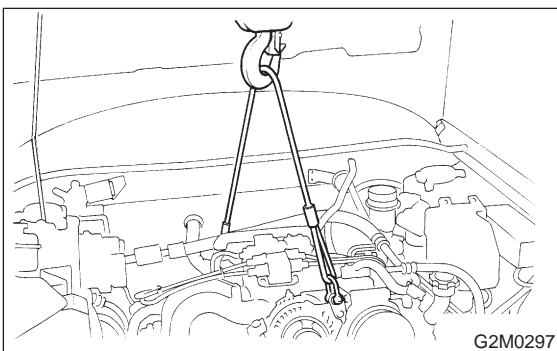

- 4) Remove garage jack.

- 5) Install pitching stopper.

Tightening torque:

$T1: 57 \pm 10 \text{ N-m (} 5.8 \pm 1.0 \text{ kg-m, } 42 \pm 7 \text{ ft-lb)}$
 $T2: 49 \pm 5 \text{ N-m (} 5.0 \pm 0.5 \text{ kg-m, } 36.2 \pm 3.6 \text{ ft-lb)}$

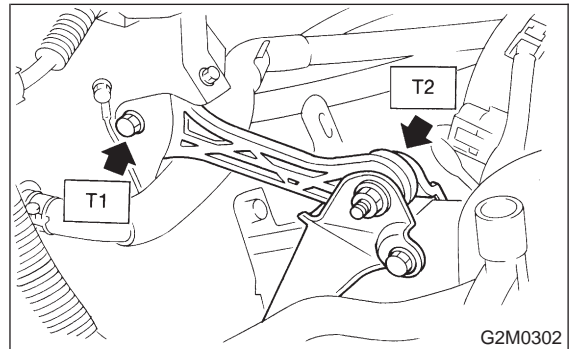

- 6) Install torque converter onto drive plate. (AT vehicles)

- (1) Tighten bolts which hold torque converter to drive plate.
- (2) Tighten other bolts while rotating the engine by using ST.

ST 499977000 CRANK PULLEY WRENCH

CAUTION:

Be careful not to drop bolts into torque converter housing.

Tightening torque:
 $25 \pm 2 \text{ N-m (} 2.5 \pm 0.2 \text{ kg-m, } 18.1 \pm 1.4 \text{ ft-lb)}$

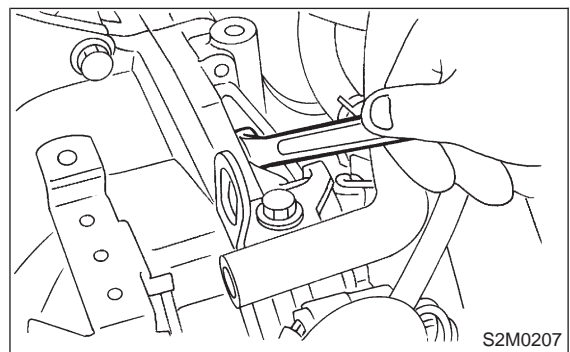

- (3) Clog plug onto service hole.

- 7) Install canister and bracket. (2200 cc FWD and Taiwan spec. vehicles)

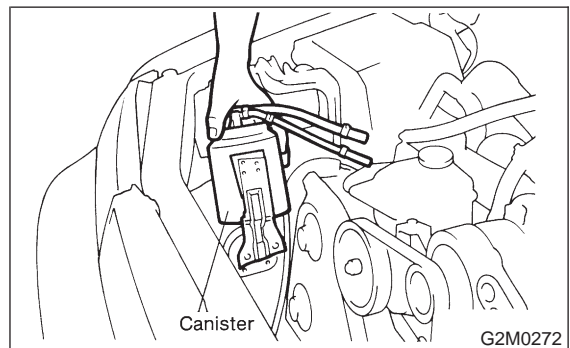

- 8) Install power steering pump on bracket.

- (1) Install power steering pump on bracket, and tighten bolts.

Tightening torque:

39±10 N·m (4.0±1.0 kg·m, 29±7 ft·lb)

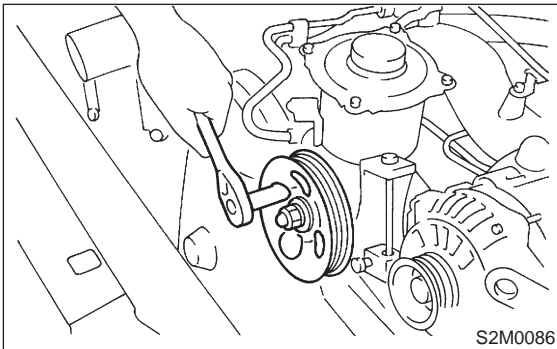

- (2) Install power steering pipe bracket on right side intake manifold, and install spark plug codes.

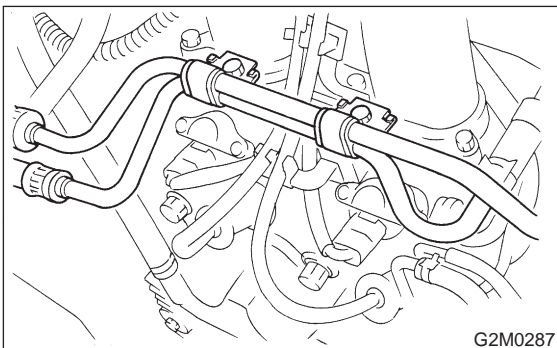

- (3) Install front side V-belt, and adjust it. <Ref. to 1-5 [G2B0].>

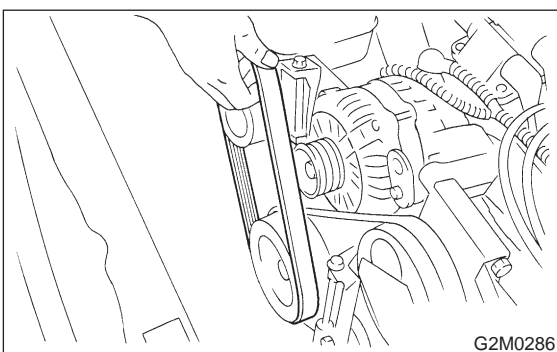

- 9) Tighten nuts which hold lower side of transmission to engine.

Tightening torque:

50±4 N·m (5.1±0.4 kg·m, 36.9±2.9 ft·lb)

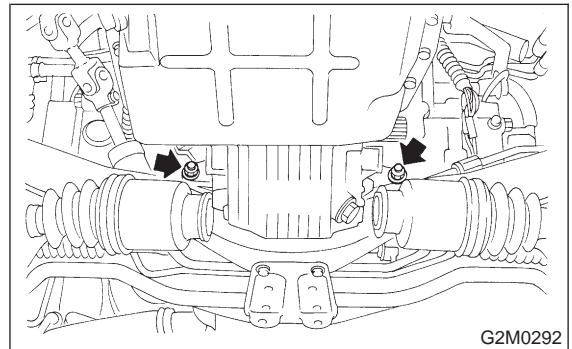

- 10) Tighten nuts which install front cushion rubber onto crossmember.

Tightening torque:

69±15 N·m (7.0±1.5 kg·m, 51±11 ft·lb)

CAUTION:

Be sure to tighten front cushion rubber mounting bolts in the innermost elliptical hole in the front crossmember.

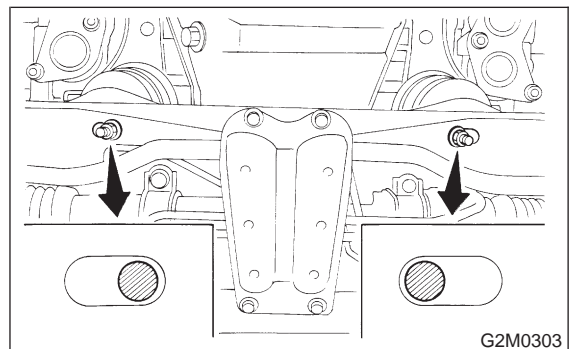

- 11) Install front exhaust pipe and center exhaust pipe. <Ref. to 2-9 [W1B0].> and <Ref. to 2-9 [W2B0].>

- 12) Connect the following hoses.

- (1) Fuel delivery hose, return hose and evaporation hose
- (2) Heater inlet and outlet hoses
- (3) Brake booster vacuum hose

- 13) Connect the following connectors.

- (1) Engine ground terminal
- (2) Engine harness connectors
- (3) Front oxygen sensor connector
- (4) Rear oxygen sensor connector (California spec. vehicles)
- (5) Alternator connector and terminal
- (6) A/C compressor connectors (With A/C)

- 14) Connect the following cables.

- (1) Accelerator cable
- (2) Cruise control cables (With cruise control)
- (3) Clutch cable (2200 cc MT vehicles)

1. Engine

(4) Clutch return spring (Models without hill holder only)

CAUTION:

After connecting each cable, adjust them.

15) Install chamber stay.

16) Install air intake system.

(1) Install air cleaner element.

(2) Install air intake duct with air cleaner upper cover.

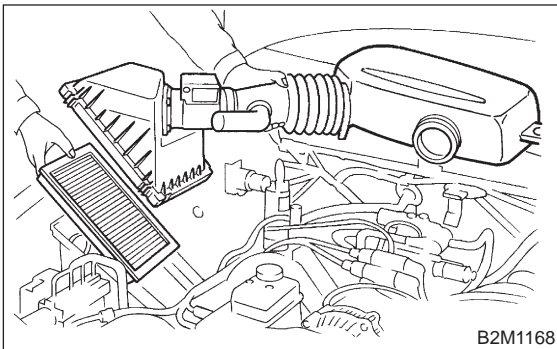

(3) Connect connector to mass air flow sensor.

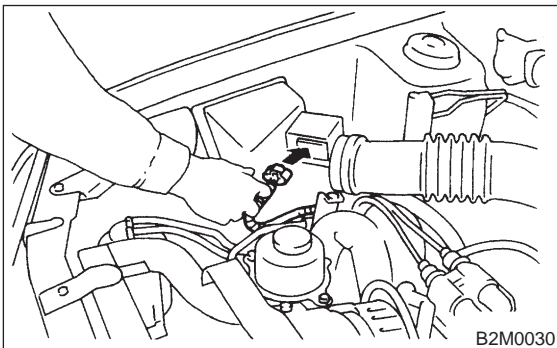

17) Install A/C flexible hoses. (With A/C)
<Ref. to 4-7 [W16A0].>

CAUTION:

Use new O-rings.

Tightening torque:

$25 \pm 7 \text{ N}\cdot\text{m}$ ($2.5 \pm 0.7 \text{ kg}\cdot\text{m}$, $18.1 \pm 5.1 \text{ ft}\cdot\text{lb}$)

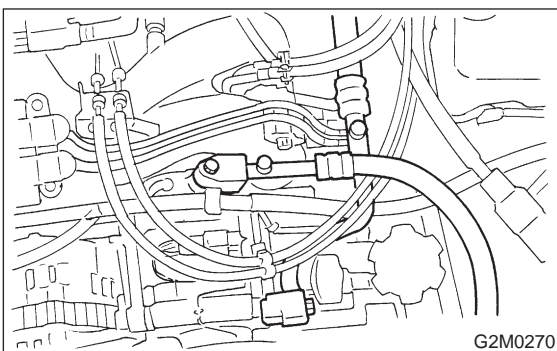

18) Install cooling system.

(1) Attach radiator mounting cushions to body.

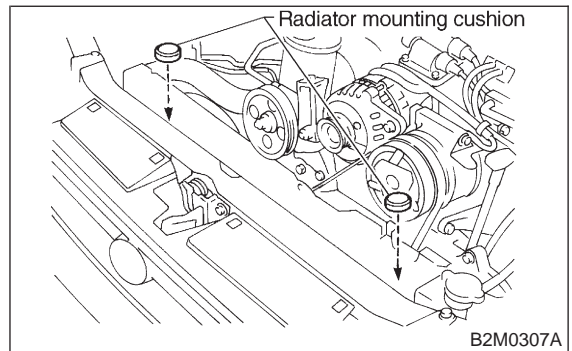

(2) Install radiator while fitting radiator pins to cushions.

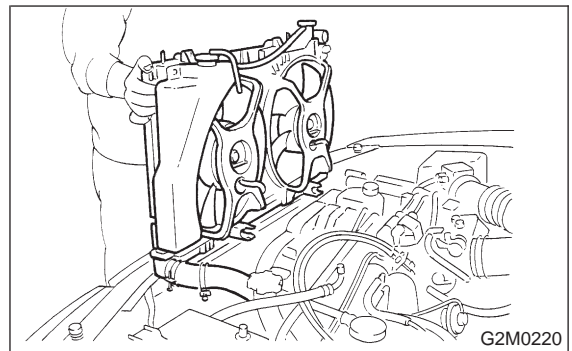

(3) Install radiator brackets and tighten bolts.

Tightening torque:

$13.7 \pm 1.5 \text{ N}\cdot\text{m}$ ($1.4 \pm 0.15 \text{ kg}\cdot\text{m}$, $10.1 \pm 1.1 \text{ ft}\cdot\text{lb}$)

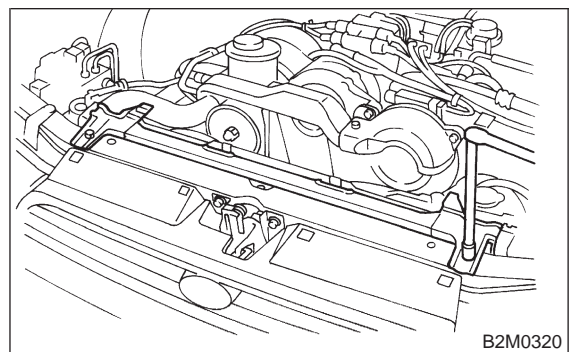

(4) Connect radiator fan motor connector.

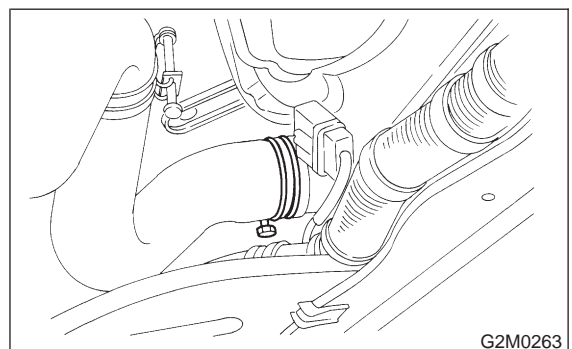

- (5) Connect radiator inlet hose.

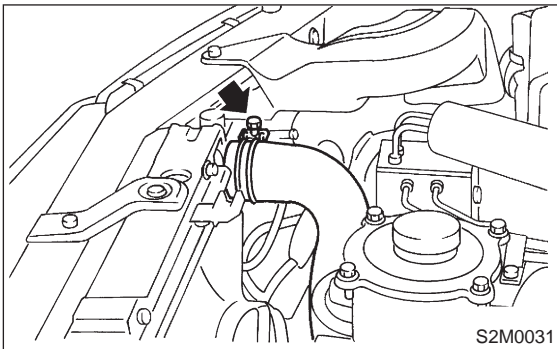

- (6) Connect radiator outlet hose.
(7) Connect ATF cooler hoses. (AT vehicles)

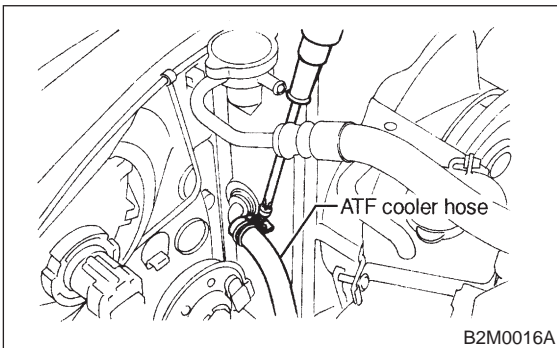

- (8) Install V-belt cover.

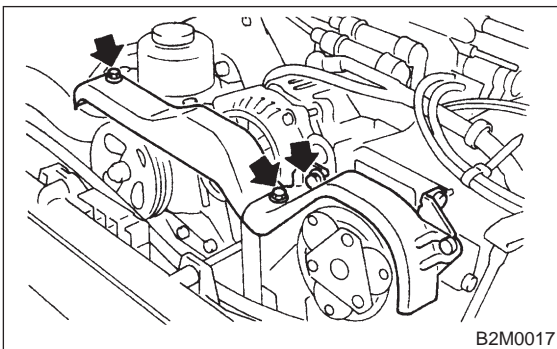

- 19) Install battery in the vehicle, and connect cables.
20) Fill coolant.
<Ref. to 2-5 [W1B0].>

Engine coolant capacity;
5.8 l (6.1 US qt, 5.1 Imp qt)

- 21) Check ATF level and correct if necessary. (AT vehicles)
<Ref. to 3-2 [W1B1].>
22) Charge A/C system with refrigerant.
<Ref. to 4-7 [W700].>
23) Remove front hood stay, and close front hood.
24) Take off the vehicle from lift arms.

2. Transmission

A: GENERAL PRECAUTION

- (1) Remove or install transmission in an area where chain hoists, lifting devices, etc. are available for ready use.
- (2) Be sure not to damage coated surfaces of body panels with tools or stain seats and windows with coolant or oil. Place a cover over fenders, as required, for protection.
- (3) Prior to starting work, prepare the following: Service tools, clean cloth, containers to catch coolant and oil, wire ropes, chain hoist, transmission jacks, etc.
- (4) Lift-up or lower the vehicle when necessary. Make sure to support the correct positions. <Ref. to 1-3 [G700].>

B: REMOVAL

- 1) Open front hood fully, and support with stay.
- 2) Disconnect battery ground terminal.
- 3) Remove air intake duct and chamber.

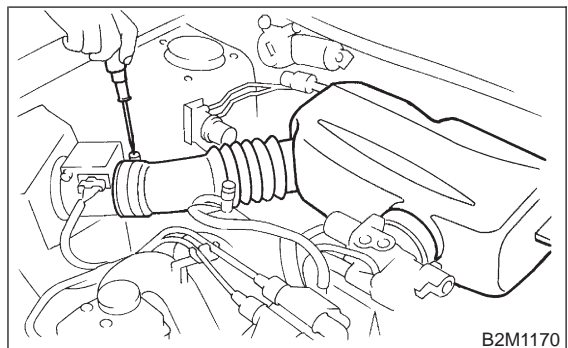

- 4) Remove chamber stay.
 - MT vehicles

