

2. Oil Pump

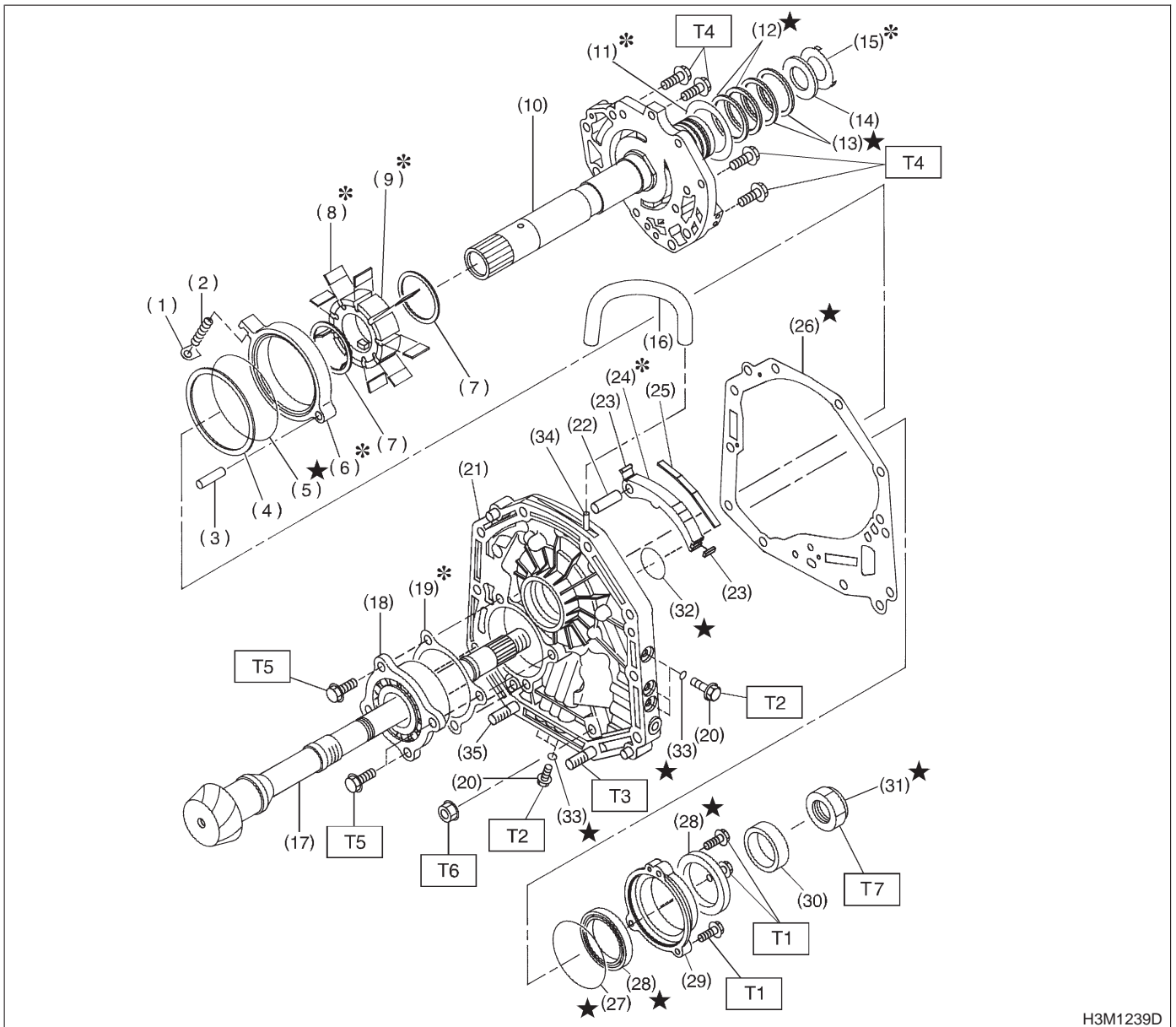

H3M1239D

- |                            |                          |                |
|----------------------------|--------------------------|----------------|
| (1) Retainer               | (16) Air breather hose   | (31) Lock nut  |
| (2) Return spring          | (17) Drive pinion shaft  | (32) O-ring    |
| (3) Pin                    | (18) Roller bearing      | (33) O-ring    |
| (4) Friction ring          | (19) Shim                | (34) Nipple    |
| (5) O-ring                 | (20) Test plug           | (35) Stud bolt |
| (6) Cam ring               | (21) Oil pump housing    |                |
| (7) Vane ring              | (22) Pin                 |                |
| (8) Vane                   | (23) Side seal           |                |
| (9) Rotor                  | (24) Control piston      |                |
| (10) Oil pump cover        | (25) Plane seal          |                |
| (11) Thrust washer         | (26) Gasket              |                |
| (12) Seal ring (R)         | (27) O-ring              |                |
| (13) Seal ring (H)         | (28) Oil seal            |                |
| (14) Thrust needle bearing | (29) Oil seal retainer   |                |
| (15) Thrust washer         | (30) Drive pinion collar |                |

**Tightening torque: N-m (kg-m, ft-lb)**

- T1: 7±1 (0.7±0.1, 5.1±0.7)**  
**T2: 13±1 (1.3±0.1, 9.4±0.7)**  
**T3: 18±5 (1.8±0.5, 13.0±3.6)**  
**T4: 25±2 (2.5±0.2, 18.1±1.4)**  
**T5: 39±3 (4.0±0.3, 28.9±2.2)**  
**T6: 41±3 (4.2±0.3, 30.4±2.2)**  
**T7: 113±5 (11.5±0.5, 83.2±3.6)**