

- 6) Install the duty solenoid B and the four brackets.
- 7) Tighten twenty seven bolts & washers and two reamer bolts.

Tightening torque:

T1: 8 ± 1 N-m (0.8 ± 0.1 kg-m, 5.8 ± 0.7 ft-lb)
T2: 11.3 ± 1.5 N-m (1.15 ± 0.15 kg-m, 8.3 ± 1.1 ft-lb)

	a	b	c	d	e
Length mm (in)	70 (2.76)	50 (1.97)	33 (1.30)	27 (1.06)	28 (1.10)
Num- bers	2	6	16	1	2

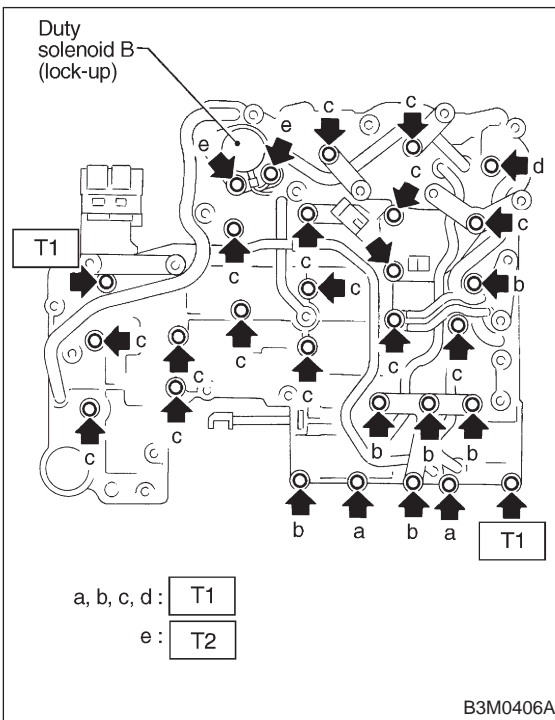

- 8) Install the shift solenoid assembly and duty solenoid A.

a length: 16 mm (0.63 in)

b length: 27 mm (1.06 in)

Tightening torque:

8 ± 1 N-m (0.8 ± 0.1 kg-m, 5.8 ± 0.7 ft-lb)

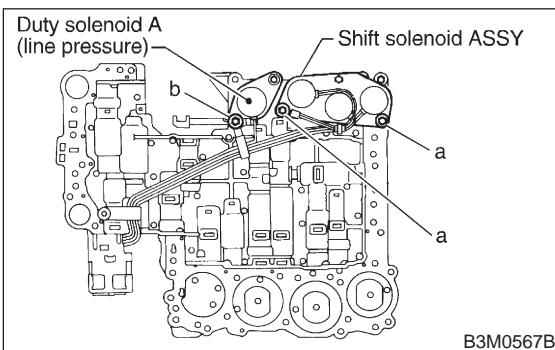

15. Oil Pump Assembly

A: DISASSEMBLY

- 1) Remove the oil seal retainer.
Also remove the O-ring and oil seal (air breather).

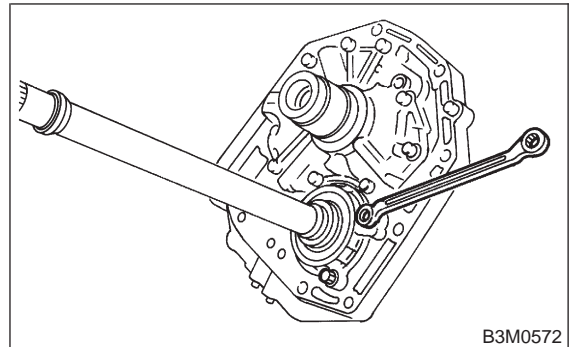

- 2) Remove the oil pump cover.

NOTE:

Lightly tap the end of the stator shaft to remove the cover.

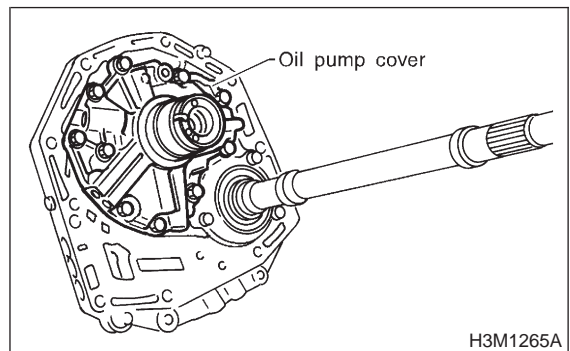

- 3) Remove the retainer and return spring. Then remove the rotor, two vane rings and nine vanes.

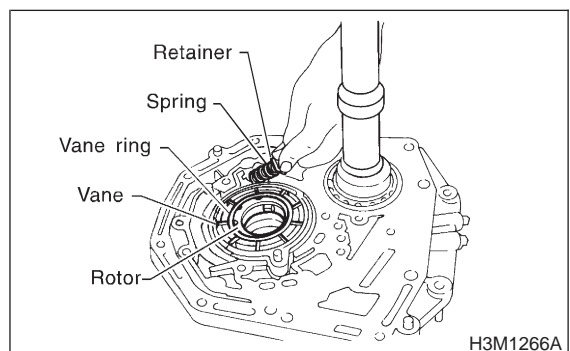

3-2 [W15B0]

15. Oil Pump Assembly

SERVICE PROCEDURE

4) Remove the cam ring and control piston. Also remove the O-ring, friction ring, two side seals, and plain seal.

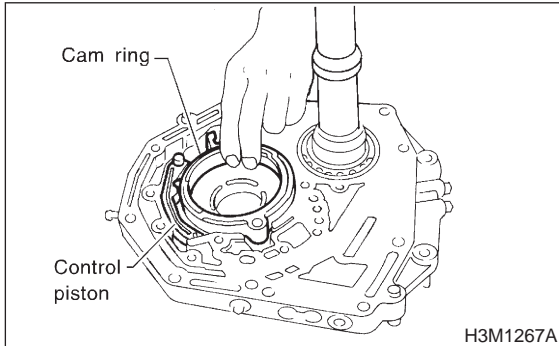

5) Remove two seal rings (R: Reverse clutch side) and two seal rings (H: High clutch side).

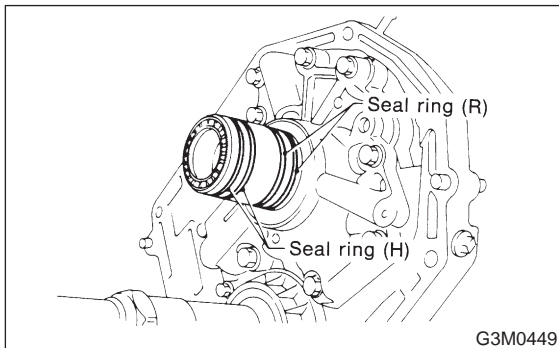

B: INSPECTION

1) Make sure that each component is free of harmful gouges, cuts, and dust.
 2) Selection of oil pump components (rotor, vanes, control piston and cam ring)

(1) Using a micrometer, measure the height of the rotor, vanes, control piston and cam ring in at least four positions. (Measure the height at one place for each of the nine vanes.)

NOTE:

- Remove the control piston seals when measuring.
- Remove the friction ring from the cam ring when measuring.

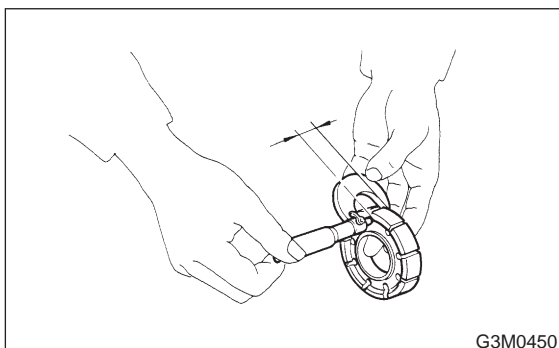

(2) Using a depth gauge, measure the depth of the oil pump housing contact and friction surfaces.

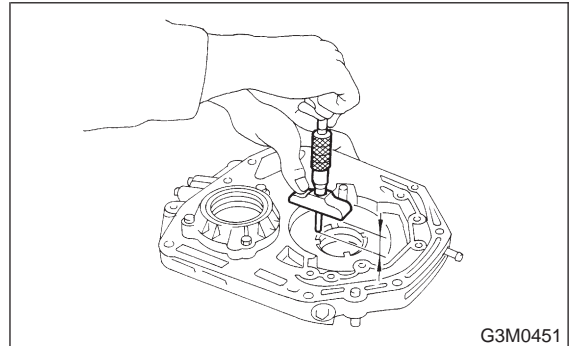

(3) Make sure that the clearances are within the specified wear limits. If the wear limit is exceeded, select pump components so that the standard clearance can be obtained.

NOTE:

Select vanes which are the same height as the rotor.

Part name	Wear limit mm (in)	Standard value mm (in)
Rotor, control piston, vanes	0.054 (0.0021)	0.030 — 0.044 (0.0012 — 0.0017)
Cam ring	0.034 (0.0013)	0.010 — 0.024 (0.0004 — 0.0009)

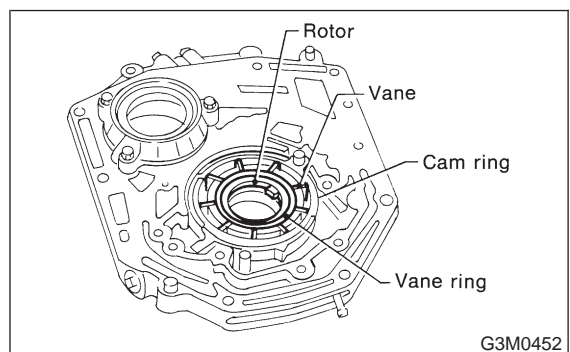

C: ASSEMBLY

1) Coat both the O-ring and friction ring with vaseline and attach to the cam ring. Then fit them into the oil pump housing.

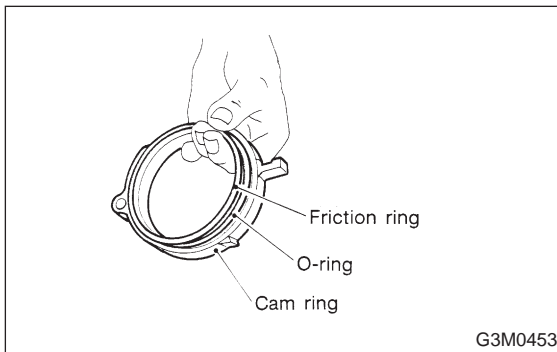

2) Install the vane ring, rotor and vanes into the housing in this sequence.

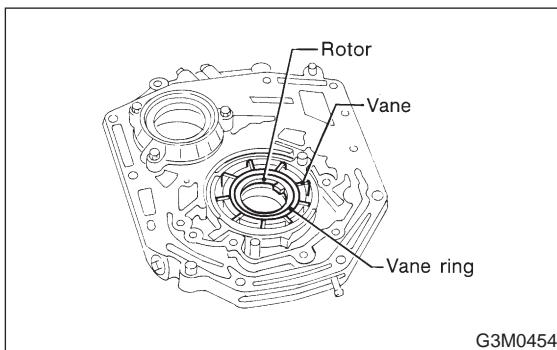

3) Install the return spring and retainer between the housing and cam ring.

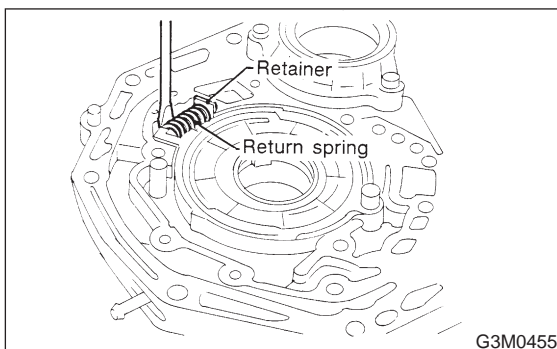

4) Install the control piston to the oil pump housing.

NOTE:

Fit the seal in the piston groove, with the red seals facing the top side. (Two side seals and one plain seal are attached.)

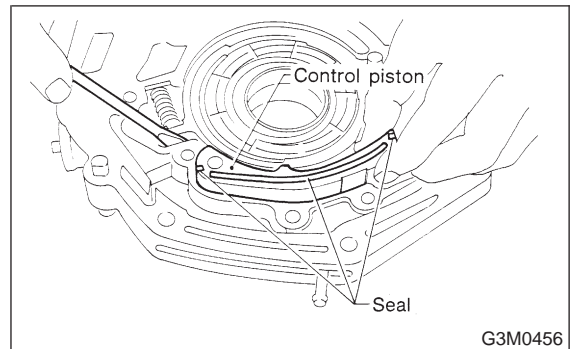

5) Set the rotor at the center of the housing bore. Apply ATF abundantly to each rotary portion.

6) Install the oil pump cover.

Tightening torque:

$25 \pm 2 \text{ N}\cdot\text{m}$ ($2.5 \pm 0.2 \text{ kg}\cdot\text{m}$, $18.1 \pm 1.4 \text{ ft}\cdot\text{lb}$)

NOTE:

- Align both pivots with the pivot holes of the cover, and install the cover being careful not to apply undue force to the pivots.
- After assembling, turn the oil pump shaft to check for smooth rotation of the rotor.

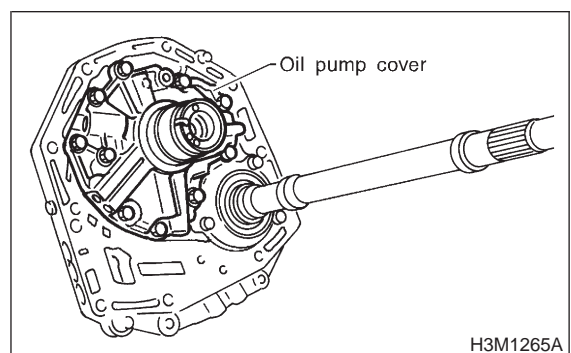

3-2 [W16A0]

16. Drive Pinion Shaft

SERVICE PROCEDURE

- Install the oil seal retainer and seal rings (R: Reverse clutch side) and (H: High clutch side) after adjusting the drive pinion backlash and tooth contact.

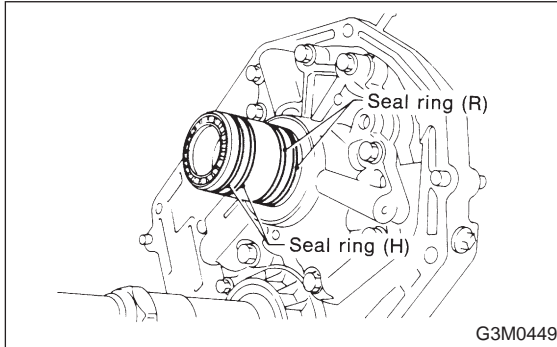

16. Drive Pinion Shaft

A: DISASSEMBLY

- 1) Straighten the staked portion of the lock nut, and remove the lock nut while locking the rear spline portion of the shaft with ST1 and ST2. Then pull off the drive pinion collar.

ST1 498937100 HOLDER
ST2 499787100 WRENCH
ST3 499757800 ADAPTER

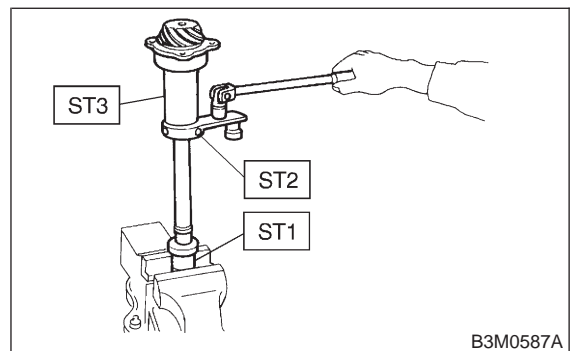

- 2) Remove the O-ring
- 3) Using a press, separate the rear roller bearing and outer race from the shaft.

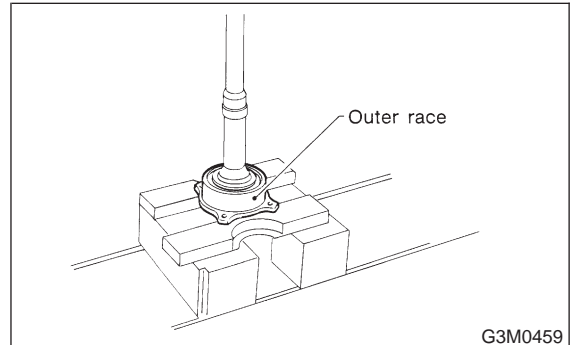

- 4) Using a press and ST, separate the front roller bearing from the shaft.

ST 498517000 REPLACER

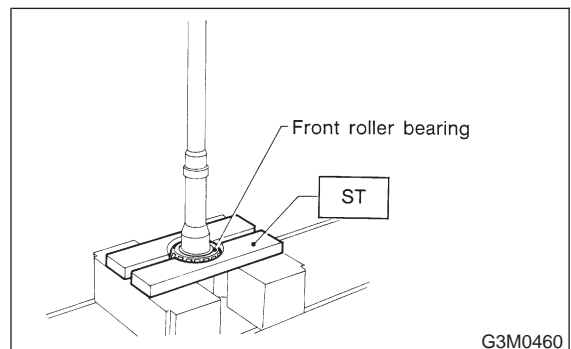

B: INSPECTION

Make sure that all component parts are free of harmful cuts, gouges, and other faults.