

4. Schematic

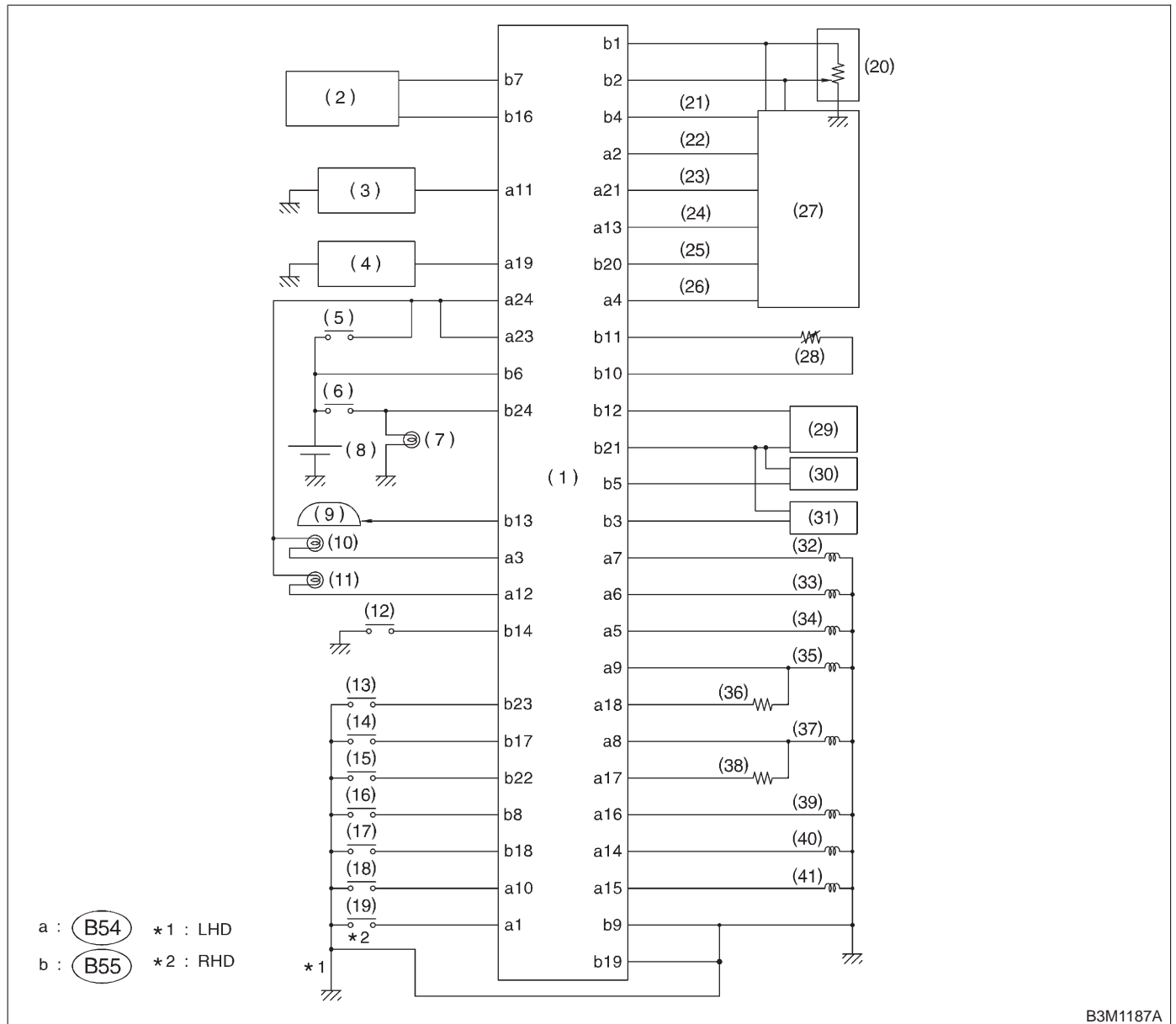

B3M1187A

- | | | |
|----------------------------------|--------------------------------|--|
| (1) Transmission control module | (15) "N" range switch | (29) Torque converter turbine speed sensor |
| (2) Data link connector | (16) "D" range switch | (30) Vehicle speed sensor 2 (Front) |
| (3) Cruise set switch | (17) "3" range switch | (31) Vehicle speed sensor 1 (Rear) |
| (4) ABS control module | (18) "2" range switch | (32) Shift solenoid 1 |
| (5) Ignition switch | (19) "1" range switch | (33) Shift solenoid 2 |
| (6) Brake switch | (20) Throttle position sensor | (34) 2-4 brake timing solenoid |
| (7) Brake light | (21) Engine speed signal | (35) Duty solenoid A |
| (8) Battery | (22) Torque control cut signal | (36) Line pressure dropping resistor |
| (9) Combination meter | (23) Torque control signal 2 | (37) Duty solenoid D |
| (10) AT OIL TEMP indicator light | (24) Torque control signal 1 | (38) 2-4 brake dropping resistor |
| (11) FWD indicator light | (25) AT load signal | (39) Duty solenoid B |
| (12) FWD switch | (26) AT diagnostics signal | (40) Low clutch timing solenoid |
| (13) "P" range switch | (27) Engine control module | (41) Duty solenoid C |
| (14) "R" range switch | (28) ATF temperature sensor | |