

## 9. Diagnostic Chart with Select Monitor

### A: BASIC DIAGNOSTIC CHART

If no trouble codes appear in the on-board diagnostics operation (although problems have occurred or are occurring), measure performance characteristics of sensors, actuators, etc., in the Subaru Select Monitor and compare with the "basic data" to determine the cause of problems.

- 1) Trouble occurs.
- 2) No trouble codes appear in on-board diagnostics operation.
- 3) Measure each item using Subaru Select Monitor.
- 4) Compare measured values with basic data.
- 5) Determine item which is outside basic data specifications.
- 6) Check sensor and actuator affected.

### B: BATTERY VOLTAGE

**9B1 : CHECK BATTERY VOLTAGE.**

- 1) Turn ignition switch to OFF.
- 2) Connect Subaru Select Monitor to data link connector.

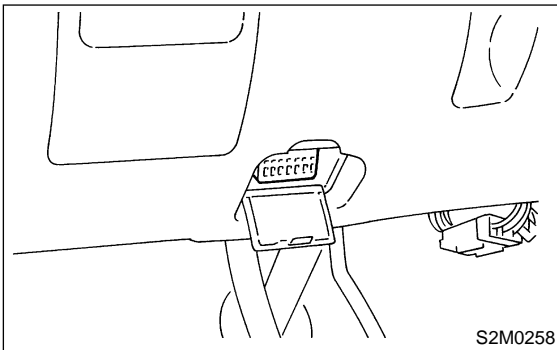

- 3) Start the engine, and engine idling after warm-up.
- 4) Turn Subaru Select Monitor switch to ON.
- 5) Read data of battery voltage using Subaru Select Monitor.

- Battery voltage applied to TCM.

- CHECK** : **Is voltage between 10 and 16 V?**
- YES** : Go to step VEHICLE SPEED SENSOR 1. <Ref. to 3-2 [T9C0].>
- NO** : Check battery voltage and specification of electrolyte, regulating voltage under no loads and generator (as a single unit).

### C: CHECK VEHICLE SPEED SENSOR 1.

**9C1 : CHECK VEHICLE SPEED SENSOR 1.**

- 1) Lift-up the vehicle and place safety stand.

**CAUTION:**

**On AWD models, raise all wheels off ground.**

- 2) Read data of vehicle speed #1 using Subaru Select Monitor.

- Compare speedometer with Subaru Select Monitor indications.
- Vehicle speed is indicated in "MPH" or "km/h".

**NOTE:**

The speed difference between front and rear wheels may light the ABS warning light, but this indicates no malfunction. When AT control diagnosis is finished, perform the ABS memory clearance procedure of on-board diagnostics system. <Ref. to 4-4 [T6D2].>

- CHECK** : **Does the speedometer indication increase as the Subaru Select Monitor data increases?**
- YES** : Go to step VEHICLE SPEED SENSOR 2. <Ref. to 3-2 [T9D0].>
- NO** : Check vehicle speed sensor 1 circuit. <Ref. to 3-2 [T8S0].>

### D: CHECK VEHICLE SPEED SENSOR 2.

**9D1 : CHECK VEHICLE SPEED SENSOR 2.**

Read data of vehicle speed #2 using Subaru Select Monitor.

- Compare speedometer with Subaru Select Monitor indications.
- Vehicle speed is indicated in "MPH" or "km/h".

**NOTE:**

The speed difference between front and rear wheels may light the ABS warning light, but this indicates no malfunction. When AT control diagnosis is finished, perform the ABS memory clearance procedure of on-board diagnostics system. <Ref. to 4-4 [T6D2].>

- CHECK** : **Does the speedometer indication increase as the Subaru Select Monitor data increases?**
- YES** : Go to step ENGINE SPEED SIGNAL. <Ref. to 3-2 [T9E0].>
- NO** : Check vehicle speed sensor 2 circuit. <Ref. to 3-2 [T8G0].>

## 3-2 [T9E1] AUTOMATIC TRANSMISSION AND DIFFERENTIAL

### 9. Diagnostic Chart with Select Monitor

#### E: CHECK ENGINE SPEED SIGNAL.

##### 9E1 : CHECK ENGINE SPEED SIGNAL.

- 1) Turn A/C switch to OFF (with A/C models).
- 2) Warm-up the engine until engine coolant temperature is above 80°C (176°F).

**NOTE:**

If ambient temperature is below 0°C (32°F), drive the vehicle until the ATF reaches its operating temperature.

- 3) Read data of engine speed using Subaru Select Monitor.

- Engine speed is indicated in “rpm”.

**NOTE:**

The speed difference between front and rear wheels may light the ABS warning light, but this indicates no malfunction. When AT control diagnosis is finished, perform the ABS memory clearance procedure of on-board diagnostics system. <Ref. to 4-4 [T6D2].>

**CHECK** : *Does the tachometer revolution increase as the Subaru Select Monitor revolution data increases?*

**YES** : Go to step ATF TEMPERATURE SENSOR. <Ref. to 3-2 [T9F0].>

**NO** : Check engine speed signal circuit. <Ref. to 3-2 [T8C0].>

#### F: CHECK ATF TEMPERATURE SENSOR.

##### 9F1 : CHECK AT OIL TEMP WARNING LIGHT.

**CHECK** : *Does the AT OIL TEMP warning light remain on 2 seconds after the engine has been started?*

**YES** : Go to step 9F2.

**NO** : Check ATF temperature sensor and combination meter circuit. <Ref. to 3-2 [T8E0].>

##### 9F2 : CHECK ATF TEMPERATURE SENSOR.

- 1) Read data of ATF temperature using Subaru Select Monitor.

- ATF temperature is indicated in “°F” or “°C”.
- 2) Warm-up the transmission until ATF temperature is above 80°C (176°F).

**NOTE:**

If ambient temperature is below 0°C (32°F), drive the vehicle until the ATF reaches its operating temperature.

- 3) Turn ignition switch to ON (engine OFF).

**CHECK** : *Does the ATF temperature change from 176°F (80°C)?*

**YES** : Go to step THROTTLE POSITION SENSOR. <Ref. to 3-2 [T9G0].>

**NO** : Check ATF temperature sensor circuit. <Ref. to 3-2 [T8E0].>

#### G: CHECK THROTTLE POSITION SENSOR.

##### 9G1 : CHECK INPUT SIGNAL FOR TCM.

Read data of throttle position sensor using Subaru Select Monitor.

- Throttle position sensor input signal is indicated.

**CHECK** : *Is voltage between 0.3 and 0.7 V when the accelerator pedal is completely released?*

**YES** : Go to step 9G2.

**NO** : Check throttle position sensor circuit. <Ref. to 3-2 [T8F0].>

##### 9G2 : CHECK INPUT SIGNAL FOR TCM.

**CHECK** : *Is voltage between 4.4 and 4.8 V when the accelerator pedal is completely depressed?*

**YES** : Go to step 9G3.

**NO** : Check throttle position sensor circuit. <Ref. to 3-2 [T8F0].>

**9G3 : CHECK INPUT SIGNAL FOR TCM.**

- CHECK** : *Does voltage decrease smoothly when the accelerator pedal is fully depressed and then fully released?*
- YES** : Go to step GEAR POSITION. <Ref. to 3-2 [T9H0].>
- NO** : Check throttle position sensor circuit. <Ref. to 3-2 [T8F0].>

**H: CHECK GEAR POSITION.**

**9H1 : CHECK GEAR POSITION.**

- 1) Lift-up the vehicle and place safety stand.

**CAUTION:**

**On AWD models, raise all wheels off ground.**

- 2) Start the engine.
- 3) Move select lever to "D", and drive vehicle.
- 4) Read data of gear position using Subaru Select Monitor.
  - Gear position is indicated.

**NOTE:**

The speed difference between front and rear wheels may light the ABS warning light, but this indicates no malfunction. When AT control diagnosis is finished, perform the ABS memory clearance procedure of on-board diagnostics system. <Ref. to 4-4 [T6D2].>

- CHECK** : *Does the transmission gear correspond to the gear which is shown on display?*
- YES** : Go to step LINE PRESSURE DUTY. <Ref. to 3-2 [T9I0].>
- NO** : Check shift solenoid 1 and shift solenoid 2 signal circuit. <Ref. to 3-2 [T8K0].> and <Ref. to 3-2 [T8L0].>

**I: CHECK LINE PRESSURE DUTY.**

**9I1 : CHECK OUTPUT SIGNAL EMITTED FROM TCM.**

- 1) Warm-up the transmission until ATF temperature is above 80°C (176°F).

**NOTE:**

If ambient temperature is below 0°C (32°F), drive the vehicle until the ATF reaches its operating temperature.

- 2) Stop the engine and turn ignition switch to ON (engine OFF).

- 3) Move selector lever to "N".

- 4) Read data of line pressure duty ratio using Subaru Select Monitor.

- Line pressure duty is indicated in "%".

- CHECK** : *Does the Subaru Select Monitor indicate 100% when the accelerator pedal is completely released?*
- YES** : Go to step 9I2.
- NO** : Go to step 9I4.

**9I2 : CHECK OUTPUT SIGNAL EMITTED FROM TCM.**

- CHECK** : *Does the Subaru Select Monitor indicate between 10 and 20% when the accelerator pedal is completely depressed?*
- YES** : Go to step 9I3.
- NO** : Go to step 9I4.

**9I3 : CHECK OUTPUT SIGNAL EMITTED FROM TCM.**

- CHECK** : *Does the Subaru Select Monitor change smoothly when the accelerator pedal is fully depressed and then fully released?*
- YES** : Go to step LOCK-UP DUTY. <Ref. to 3-2 [T9J0].>
- NO** : Go to step 9I4.

## 3-2 [T9I4] AUTOMATIC TRANSMISSION AND DIFFERENTIAL

### 9. Diagnostic Chart with Select Monitor

#### 9I4 : CHECK THROTTLE POSITION SENSOR.

##### NOTE:

For the diagnostics procedure on throttle position sensor circuit, <Ref. to 3-2 [T9G0].>

- CHECK** : *Is there any trouble in throttle position sensor circuit?*
- YES** : Repair or replace throttle position sensor circuit, <Ref. to 3-2 [T8F0].>
- NO** : Go to step **9I5**.

#### 9I5 : CHECK ENGINE SPEED SIGNAL.

##### NOTE:

For the diagnostics procedure on engine speed signal circuit, <Ref. to 3-2 [T9E0].>

- CHECK** : *Is there any trouble in engine speed signal circuit?*
- YES** : Repair or replace engine speed signal circuit, <Ref. to 3-2 [T8C0].>
- NO** : Go to step **9I6**.

#### 9I6 : CHECK ATF TEMPERATURE SENSOR.

##### NOTE:

For the diagnostics procedure on ATF temperature sensor circuit, <Ref. to 3-2 [T9F1].>

- CHECK** : *Is there any trouble in ATF temperature sensor circuit?*
- YES** : Repair or replace ATF temperature sensor circuit, <Ref. to 3-2 [T8E0].>
- NO** : Go to step **9I7**.

#### 9I7 : CHECK INHIBITOR SWITCH.

1) Turn ignition switch and Subaru Select Monitor to ON.

2) Read data of range switch using Subaru Select Monitor.

- Range switch is indicated in ON ⇔ OFF.

- CHECK** : *When each range is selected, does LED of the range switch on Subaru Select Monitor light up?*
- YES** : Go to step LOCK-UP DUTY. <Ref. to 3-2 [T9J0].>
- NO** : Check inhibitor switch circuit. <Ref. to 3-2 [T9U0].>

#### J: CHECK LOCK-UP DUTY.

#### 9J1 : CHECK OUTPUT SIGNAL EMITTED FROM TCM.

Read data of lock-up duty ratio using Subaru Select Monitor.

- Lock-up duty ratio is indicated in “%”.

- CHECK** : *Does the Subaru Select Monitor indicate 5%?*
- YES** : Go to step **9J2**.
- NO** : Go to step **9J3**.

#### 9J2 : CHECK OUTPUT SIGNAL EMITTED FROM TCM.

Move selector lever to “D” and slowly increase vehicle speed to 75 km/h (47 MPH).

##### NOTE:

The speed difference between front and rear wheels may light the ABS warning light, but this indicates no malfunction. When AT control diagnosis is finished, perform the ABS memory clearance procedure of on-board diagnostics system. <Ref. to 4-4 [T6D2].>

- CHECK** : *Does the Subaru Select Monitor indicate 95%?*
- YES** : Go to step TRANSFER DUTY RATIO. <Ref. to 3-2 [T9K0].>
- NO** : Go to step **9J3**.

#### 9J3 : CHECK THROTTLE POSITION SENSOR.

##### NOTE:

For the diagnostics procedure on throttle position sensor circuit, <Ref. to 3-2 [T9G0].>

- CHECK** : *Is there any trouble in throttle position sensor circuit?*
- YES** : Repair or replace throttle position sensor circuit, <Ref. to 3-2 [T9L0].>
- NO** : Go to step **9J4**.

**9J4 : CHECK VEHICLE SPEED SENSOR 1.**

**NOTE:**

For the diagnostics procedure on vehicle speed sensor 1 circuit, <Ref. to 3-2 [T9C0].>.

- CHECK** : ***Is there any trouble in vehicle speed sensor 1 circuit?***
- YES** : Repair or replace vehicle speed sensor 1 circuit, <Ref. to 3-2 [T8S0].>.
- NO** : Go to step **9J5**.

**9J5 : CHECK VEHICLE SPEED SENSOR 2.**

**NOTE:**

For the diagnostics procedure on vehicle speed sensor 2 circuit, <Ref. to 3-2 [T9D0].>.

- CHECK** : ***Is there any trouble in vehicle speed sensor 2 circuit?***
- YES** : Repair or replace vehicle speed sensor 2 circuit, <Ref. to 3-2 [T8G0].>.
- NO** : Go to step **9J6**.

**9J6 : CHECK ENGINE SPEED SIGNAL.**

**NOTE:**

For the diagnostics procedure on engine speed signal circuit, <Ref. to 3-2 [T9E0].>.

- CHECK** : ***Is there any trouble in engine speed signal circuit?***
- YES** : Repair or replace engine speed signal circuit, <Ref. to 3-2 [T8C0].>.
- NO** : Go to step **9J7**.

**9J7 : CHECK INHIBITOR SWITCH.**

Read data of range switch using Subaru Select Monitor.

- Range switch is indicated in ON ⇔ OFF.

- CHECK** : ***When each range is selected, does LED of the range switch on Subaru Select Monitor light up?***
- YES** : Go to step TRANSFER DUTY. <Ref. to 3-2 [T9K0].>
- NO** : Check inhibitor switch circuit. <Ref. to 3-2 [T9U0].>

**K: CHECK TRANSFER DUTY.**

**9K1 : CHECK OUTPUT SIGNAL EMITTED FROM TCM.**

- 1) Turn ignition switch to ON (engine OFF).
  - 2) Move selector lever to "D".
  - 3) Read data of transfer duty ratio using Subaru Select Monitor.
- Transfer duty ratio is indicated in "%".

- CHECK** : ***Does the duty ratio change in response to the depress-release motion of the accelerator pedal?***

- YES** : Go to step **9K2**.
- NO** : Go to step **9K3**.

**9K2 : CHECK OUTPUT SIGNAL EMITTED FROM TCM.**

- 1) Turn ignition switch to OFF.
- 2) Set FWD mode.
- 3) Turn ignition switch to ON (engine OFF).

- CHECK** : ***Does the Subaru Select Monitor indicate 95%?***

- YES** : Go to step THROTTLE POSITION SENSOR POWER SUPPLY. <Ref. to 3-2 [T9L0].>
- NO** : Go to step **9K3**.

**9K3 : CHECK THROTTLE POSITION SENSOR.**

**NOTE:**

For the diagnostics procedure on throttle position sensor circuit, <Ref to 3-2 [T9G0].>.

- CHECK** : ***Is there any trouble in throttle position sensor circuit?***
- YES** : Repair or replace throttle position sensor circuit, <Ref. to 3-2 [T8F0].>.
- NO** : Go to step **9K4**.

**9K4 : CHECK VEHICLE SPEED SENSOR 1.**

**NOTE:**

For the diagnostics procedure on vehicle speed sensor 1 circuit, <Ref. to 3-2 [T9C0].>.

- CHECK** : ***Is there any trouble in vehicle speed sensor 1 circuit?***
- YES** : Repair or replace vehicle speed sensor 1 circuit, <Ref to 3-2 [T8S0].>.
- NO** : Go to step **9K5**.

## 3-2 [T9K5] AUTOMATIC TRANSMISSION AND DIFFERENTIAL

### 9. Diagnostic Chart with Select Monitor

#### 9K5 : CHECK VEHICLE SPEED SENSOR 2 CIRCUIT.

##### NOTE:

For the diagnostics procedure on vehicle speed sensor 2 circuit, <Ref. to 3-2 [T9D0].>.

- CHECK** : *Is there any trouble in vehicle speed sensor 2 circuit?*
- YES** : Repair or replace vehicle speed sensor 2 circuit, <Ref. to 3-2 [T8G0].>.
- NO** : Go to step **9K6**.

#### 9K6 : CHECK ATF TEMPERATURE SENSOR.

##### NOTE:

For the diagnostics procedure on ATF temperature sensor circuit, <Ref. to 3-2 [T9F0].>.

- CHECK** : *Is there any trouble in ATF temperature sensor circuit?*
- YES** : Repair or replace ATF temperature sensor circuit, <Ref. to 3-2 [T8E0].>.
- NO** : Go to step **9K7**.

#### 9K7 : CHECK INHIBITOR SWITCH.

Read data of range switch using Subaru Select Monitor.

- Range switch is indicated in ON ⇔ OFF.

- CHECK** : *When each range is selected, does LED of range switch on Subaru Select Monitor light up?*
- YES** : Go to step **9K8**.
- NO** : Check inhibitor switch circuit. <Ref. to 3-2 [T9U0].>

#### 9K8 : CHECK ABS SIGNAL.

1) Start the engine, and turn Subaru Select Monitor switch to ON.

2) Read data of ABS signal using Subaru Select Monitor.

- ABS switch is indicated in ON ⇔ OFF.

- CHECK** : *Does the LED of ABS switch light up?*
- YES** : Check ABS signal circuit. <Ref. to 4-4 [T10A0].> and <Ref. to 4-4 [T10U0].>
- NO** : Go to step THROTTLE POSITION SENSOR POWER SUPPLY. <Ref. to 3-2 [T9L0].>

#### L: CHECK THROTTLE POSITION SENSOR POWER SUPPLY.

#### 9L1 : CHECK THROTTLE POSITION POWER SUPPLY.

Read data of throttle position sensor power supply using Subaru Select Monitor.

- Throttle position sensor power supply voltage is indicated.

- CHECK** : *Is the value fixed between 5.02 and 5.22 V?*
- YES** : Go to step MASS AIR FLOW SIGNAL. <Ref. to 3-2 [T9M0].>
- NO** : Check throttle position sensor power supply circuit. <Ref. to 3-2 [T8F0].>

#### M: CHECK MASS AIR FLOW SIGNAL. (EXCEPT 2200 cc CALIFORNIA SPEC. VEHICLES)

#### 9M1 : CHECK VEHICLE MARKET.

- CHECK** : *Is it 2200 cc California spec. vehicle?*
- YES** : Go to step INTAKE MANIFOLD PRESSURE SIGNAL. <Ref. to 3-2 [T9N0].>
- NO** : Go to step **9M2**.

#### 9M2 : CHECK INPUT SIGNAL FOR TCM.

- 1) Start the engine.
- 2) Warm-up the engine until engine coolant temperature is above 80°C (176°F).

##### NOTE:

If ambient temperature is below 0°C (32°F), drive the vehicle until the ATF reaches its operating temperature.

- 3) Engine idling after warm-up.
  - 4) Move selector lever to "N".
  - 5) Read data of mass air flow signal using Subaru Select Monitor.
- Display shows mass air flow signal value sent from ECM.

- CHECK** : *Does voltage change in response to the depress-release motion of the accelerator pedal?*
- YES** : Go to step **9M3**.
- NO** : Check mass air flow signal circuit. <Ref. to 3-2 [T8D0].>

**9M3 : CHECK ECM.**

- CHECK** : *Has trouble been eliminated after ECM replacement?*
- YES** : Replace ECM. <Ref. to 2-7 [W15A0].>
- NO** : Go to step **9M4**.

**9M4 : CHECK TCM.**

NOTE:  
Install former ECM.

- CHECK** : *Has trouble been eliminated after TCM replacement?*
- YES** : Replace TCM. <Ref. to 3-2 [W22A0].>
- NO** : Go to step TURBINE SPEED SENSOR. <Ref. to 3-2 [T900].>

**N: CHECK INTAKE MANIFOLD PRESSURE SIGNAL. (2200 cc CALIFORNIA SPEC. VEHICLES)**

**9N1 : CHECK INPUT SIGNAL FOR TCM.**

- 1) Start the engine.
- 2) Warm-up the engine until engine coolant temperature is above 80°C (176°F).

NOTE:  
If ambient temperature is below 0°C (32°F), drive the vehicle until the ATF reaches its operating temperature.

- 3) Engine idling after warm-up.
- 4) Move selector lever to "N".
- 5) Read data of intake manifold pressure signal using Subaru Select Monitor.
  - Display shows intake manifold pressure signal value sent from ECM.

- CHECK** : *Does voltage change in response to the depress-release motion of the accelerator pedal?*
- YES** : Go to step **9N2**.
- NO** : Check intake manifold pressure signal circuit. <Ref. to 3-2 [T8J0].>

**9N2 : CHECK ECM.**

- CHECK** : *Has trouble been eliminated after ECM replacement?*
- YES** : Replace ECM. <Ref. to 2-7 [W15A0].>
- NO** : Go to step **9N3**.

**9N3 : CHECK TCM.**

NOTE:  
Install former ECM.

- CHECK** : *Has trouble been eliminated after TCM replacement?*
- YES** : Replace TCM. <Ref. to 3-2 [W22A0].>
- NO** : Go to step TORQUE CONVERTER TURBINE SPEED SENSOR. <Ref. to 3-2 [T900].>

**O: CHECK TORQUE CONVERTER TURBINE SPEED SENSOR.**

**9O1 : CHECK TORQUE CONVERTER TURBINE SPEED SENSOR.**

- 1) Lift-up the vehicle and place safety stand.

**CAUTION:**  
On AWD models, raise all wheels off ground.

- 2) Read data of torque converter turbine speed sensor using Subaru Select Monitor.
  - Compare speedometer with Subaru Select Monitor indications.
  - Vehicle speed is indicated in "MPH" or "km/h".

NOTE:  
The speed difference between front and rear wheels may light the ABS warning light, but this indicates no malfunction. When AT control diagnosis is finished, perform the ABS memory clearance procedure of on-board diagnostics system. <Ref. to 4-4 [T6D2].>

- CHECK** : *Does the speedometer indication increase as the Subaru Select Monitor data increases?*
- YES** : Go to step 2-4 BRAKE PRESSURE DUTY. <Ref. to 3-2 [T9P0].>
- NO** : Check turbine speed sensor circuit. <Ref. to 3-2 [T8H0].>

## 3-2 [T9P1] AUTOMATIC TRANSMISSION AND DIFFERENTIAL

### 9. Diagnostic Chart with Select Monitor

#### P: CHECK 2-4 BRAKE PRESSURE DUTY.

##### 9P1 : CHECK OUTPUT SIGNAL EMITTED FROM TCM.

1) Warm-up the transmission until ATF temperature is above 80°C (176°F).

##### NOTE:

If ambient temperature is below 0°C (32°F), drive the vehicle until the ATF reaches its operating temperature.

2) Stop the engine and turn ignition switch to ON (engine OFF).

3) Move selector lever to "N".

4) Read data of 2-4 brake pressure duty ratio using Subaru Select Monitor.

- 2-4 brake pressure duty is indicated in "%".

**CHECK** : *Does the Subaru Select Monitor indicate 100% when the accelerator pedal is completely released?*

**YES** : Go to step 9P2.

**NO** : Go to step 9P4.

##### 9P2 : CHECK OUTPUT SIGNAL EMITTED FROM TCM.

**CHECK** : *Does the Subaru Select Monitor indicate between 10 and 20% when the accelerator pedal is completely depressed?*

**YES** : Go to step 9P3.

**NO** : Go to step 9P4.

##### 9P3 : CHECK OUTPUT SIGNAL EMITTED FROM TCM.

**CHECK** : *Does the Subaru Select Monitor change smoothly when the accelerator pedal is fully depressed and then fully released?*

**YES** : Go to step FWD SWITCH. <Ref. to 3-2 [T9Q0].>

**NO** : Go to step 9P4.

##### 9P4 : CHECK THROTTLE POSITION SENSOR.

##### NOTE:

For the diagnostics procedure on throttle position sensor circuit, <Ref. to 3-2 [T9G0].>.

**CHECK** : *Is there any trouble in throttle position sensor circuit?*

**YES** : Repair or replace throttle position sensor circuit, <Ref. to 3-2 [T8F0].>.

**NO** : Go to step 9P5.

##### 9P5 : CHECK ENGINE SPEED SIGNAL.

##### NOTE:

For the diagnostics procedure on engine speed signal circuit, <Ref. to 3-2 [T9E0].>.

**CHECK** : *Is there any trouble in engine speed signal circuit?*

**YES** : Repair or replace engine speed signal circuit, <Ref. to 3-2 [T8C0].>.

**NO** : Go to step 9P6.

##### 9P6 : CHECK ATF TEMPERATURE SENSOR.

##### NOTE:

For the diagnostics procedure on ATF temperature sensor circuit, <Ref. to 3-2 [T9F0].>.

**CHECK** : *Is there any trouble in ATF temperature sensor circuit?*

**YES** : Repair or replace ATF temperature sensor circuit, <Ref. to 3-2 [T8E0].>.

**NO** : Go to step 9P7.

##### 9P7 : CHECK INHIBITOR SWITCH.

1) Turn ignition switch and Subaru Select Monitor to ON.

2) Read data of range switch using Subaru Select Monitor.

- Range switch is indicated in ON ⇔ OFF.

**CHECK** : *When each range is selected, does LED of the range switch on Subaru Select Monitor light up?*

**YES** : Go to step FWD SWITCH. <Ref. to 3-2 [T9Q0].>

**NO** : Check inhibitor switch circuit. <Ref. to 3-2 [T9U0].>



**Q: CHECK FWD SWITCH.**

**DIAGNOSIS:**

- LED does not come on even if FWD switch is ON.
- FWD switch circuit is open or short.

**WIRING DIAGRAM:**

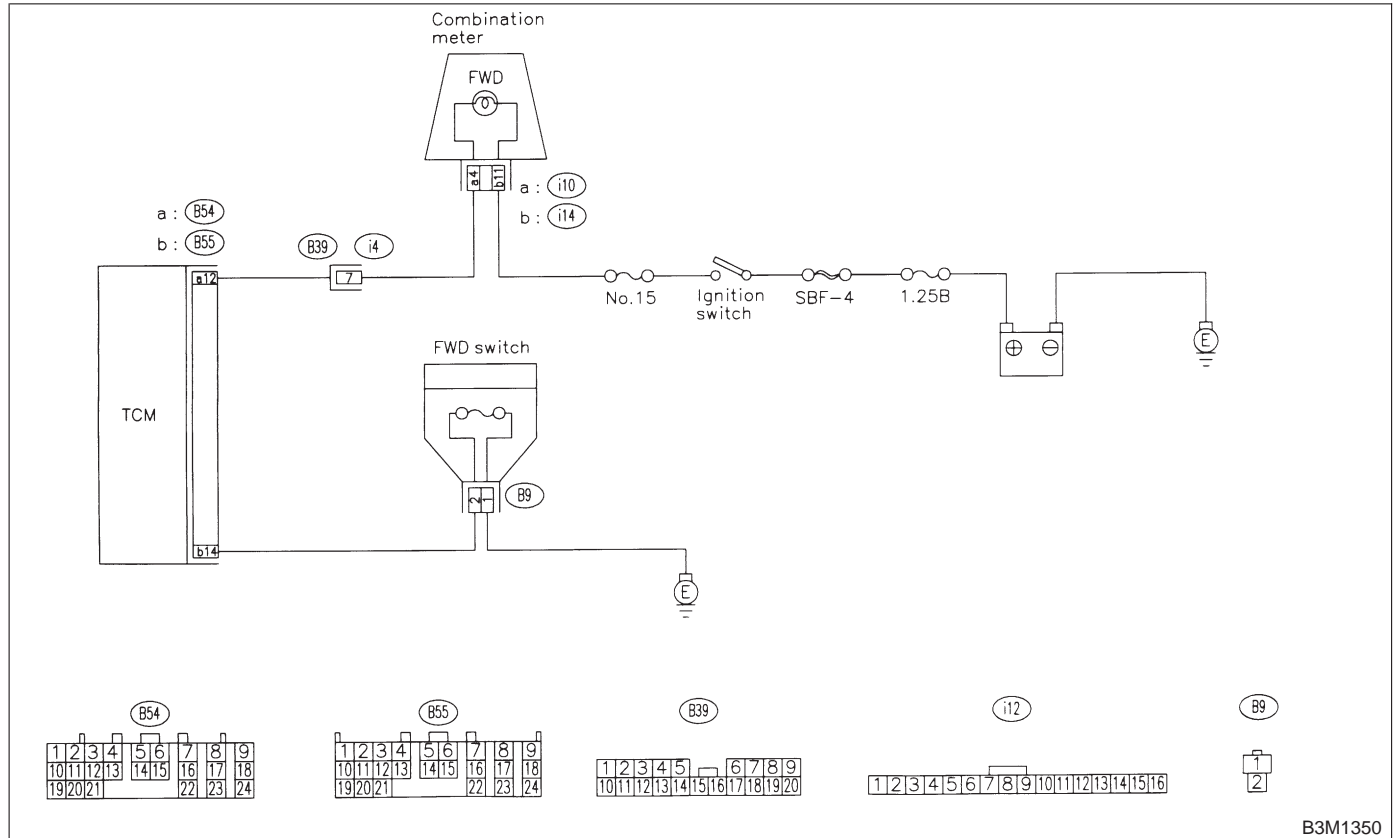

B3M1350

**9Q1 : CHECK FWD SWITCH.**

- CHECK** : *When fuse is inserted to FWD switch, does LED light up?*
- YES** : Go to step BRAKE SWITCH. <Ref. to 3-2 [T9R0].>
- NO** : Go to step **9Q2**.

## 3-2 [T9Q2] AUTOMATIC TRANSMISSION AND DIFFERENTIAL

### 9. Diagnostic Chart with Select Monitor

#### 9Q2 : CHECK HARNESS CONNECTOR BETWEEN TCM AND FWD SWITCH.

- 1) Turn ignition switch to OFF.
- 2) Disconnect connector from TCM and FWD switch.
- 3) Measure resistance of harness between TCM and FWD switch connector.

**Connector & terminal**  
(B55) No. 14 (+) — (B9) No. 2:

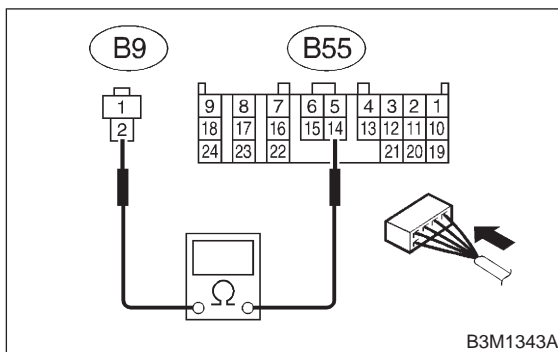

- CHECK** : Is the resistance less than 1 Ω?
- YES** : Go to step 9Q3.
- NO** : Repair open circuit in harness between TCM and FWD switch connector.

#### 9Q3 : CHECK HARNESS CONNECTOR BETWEEN TCM AND FWD SWITCH.

Measure resistance of harness connector between TCM and body to make sure that circuit does not short.

**Connector & terminal**  
(B55) No. 14 — Chassis ground:

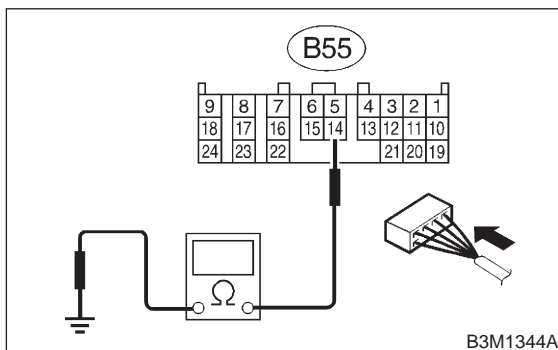

- CHECK** : Is the resistance more than 1 MΩ?
- YES** : Go to step 9Q4.
- NO** : Repair short circuit in harness connector between TCM and chassis ground.

#### 9Q4 : CHECK INPUT SIGNAL FOR TCM.

- 1) Turn ignition switch to OFF.
- 2) Connect connector to TCM and FWD switch.
- 3) Turn ignition switch to ON.
- 4) Measure signal voltage for TCM while installing the fuse to FWD switch connector.

**Connector & terminal**  
(B55) No. 14 (+) — Chassis ground (-):

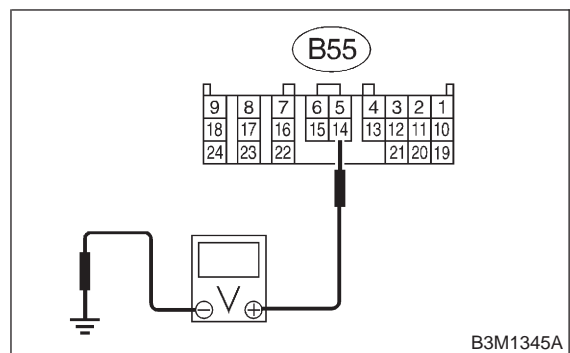

- CHECK** : Is the voltage less than 1 V in FWD switch while installing?
- YES** : Go to step 9Q5.
- NO** : Go to step 9Q10.

#### 9Q5 : CHECK INPUT SIGNAL FOR TCM.

Measure signal voltage for TCM while removing the fuse from FWD switch connector.

**Connector & terminal**  
(B55) No. 14 (+) — Chassis ground (-):

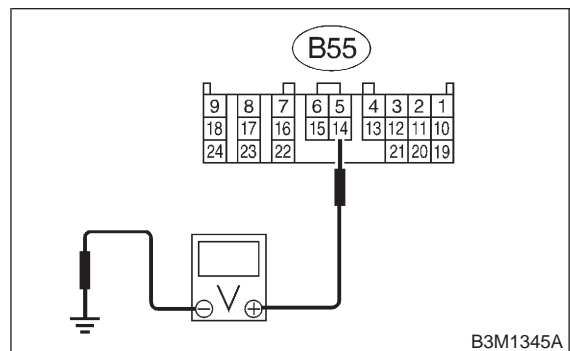

- CHECK** : Is the voltage more than 10 V in FWD switch while removing?
- YES** : Go to step 9Q6.
- NO** : Replace TCM. <Ref. to 3-2 [W22A0].>

**9Q6 : CHECK HARNESS CONNECTOR BETWEEN TCM AND COMBINATION METER.**

- 1) Turn ignition switch to OFF.
- 2) Disconnect connector from TCM and combination meter.
- 3) Measure resistance of harness between TCM and diagnosis connector.

**Connector & terminal**  
**(B54) No. 12 — (i10) No. 4:**

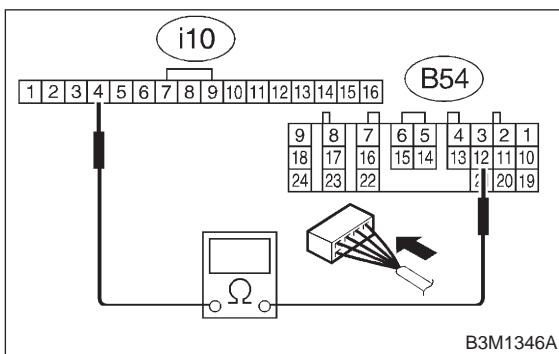

- CHECK** : **Is the resistance less than 1 Ω?**
- YES** : Go to step **9Q7**.
- NO** : Repair open circuit in harness between TCM and combination meter and poor contact in coupling connector.

**9Q7 : CHECK HARNESS CONNECTOR BETWEEN TCM AND COMBINATION METER.**

Measure resistance of harness connector between TCM and chassis ground to make sure that circuit does not short.

**Connector & terminal**  
**(B54) No. 12 — Chassis ground:**

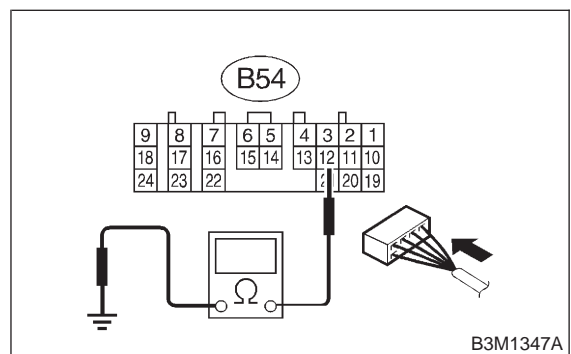

- CHECK** : **Is the resistance more than 1 MΩ?**
- YES** : Go to step **9Q8**.
- NO** : Repair short circuit in harness between TCM and combination meter connector.

**9Q8 : CHECK OUTPUT SIGNAL EMITTED FROM TCM.**

- 1) Turn ignition switch to OFF.
- 2) Connect connector to TCM and combination meter.
- 3) Turn ignition switch to ON.
- 4) Measure signal voltage for TCM while installing and removing the fuse to FWD switch connector.

**Connector & terminal**  
**(B54) No. 12 — Chassis ground:**

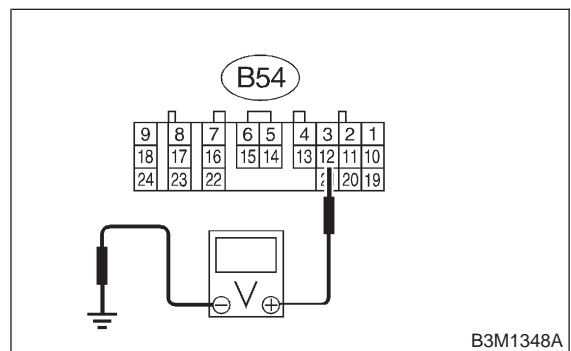

- CHECK** : **Is the voltage less than 1 V in FWD switch while installing?**
- YES** : Go to step **9Q9**.
- NO** : Go to step **9Q10**.

## 3-2 [T9Q9] AUTOMATIC TRANSMISSION AND DIFFERENTIAL

### 9. Diagnostic Chart with Select Monitor

#### 9Q9 : CHECK OUTPUT SIGNAL EMITTED FROM TCM.

Measure signal voltage for TCM while removing the fuse from FWD switch connector.

#### Connector & terminal

(B54) No. 12 — Chassis ground:

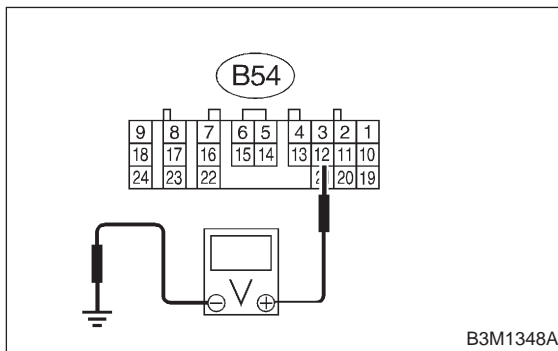

**CHECK** : *Is the voltage more than 10 V in FWD switch while removing?*

**YES** : Go to step 9Q10.

**NO** : Replace TCM. <Ref. to 3-2 [W22A0].>

#### 9Q10 : CHECK POOR CONTACT.

**CHECK** : *Is there poor contact in FWD switch circuit?*

**YES** : Repair poor contact.

**NO** : Replace TCM. <Ref. to 3-2 [W22A0].>

## R: CHECK BRAKE SWITCH.

#### 9R1 : CHECK BRAKE SWITCH.

**CHECK** : *When the brake pedal is depressed, does LED light up?*

**YES** : Go to step ABS SWITCH. <Ref. to 3-2 [T9S0].>

**NO** : Check brake switch circuit. 2200 cc LHD; <Ref. to 2-7 [T12AY0].>, 2500 cc LHD; <Ref. to 2-7 [T16BJ0].>, RHD; <Ref. to 2-7 [T14AW0].>

## S: CHECK ABS SWITCH.

#### 9S1 : CHECK ABS SWITCH.

**CHECK** : *Does the LED of ABS switch light up?*

**YES** : Check ABS switch circuit. <Ref. to 4-4 [T10A0].> and <Ref. to 4-4 [T10U0].>

**NO** : Go to step CRUISE CONTROL SWITCH. <Ref. to 3-2 [T9T0].>

## T: CHECK CRUISE CONTROL SWITCH.

#### 9T1 : CHECK CRUISE CONTROL SWITCH.

**CHECK** : *When cruise control is set, does LED light up?*

**YES** : Go to step "N/P" RANGE SWITCH. <Ref. to 3-2 [T9U0].>

**NO** : Check cruise control. <Ref. to 6-2 [W2200].>

**U: CHECK "N/P" RANGE SWITCH.**

**DIAGNOSIS:**

Input signal circuit of "P" or "N" range is open or shorted.

**WIRING DIAGRAM:**

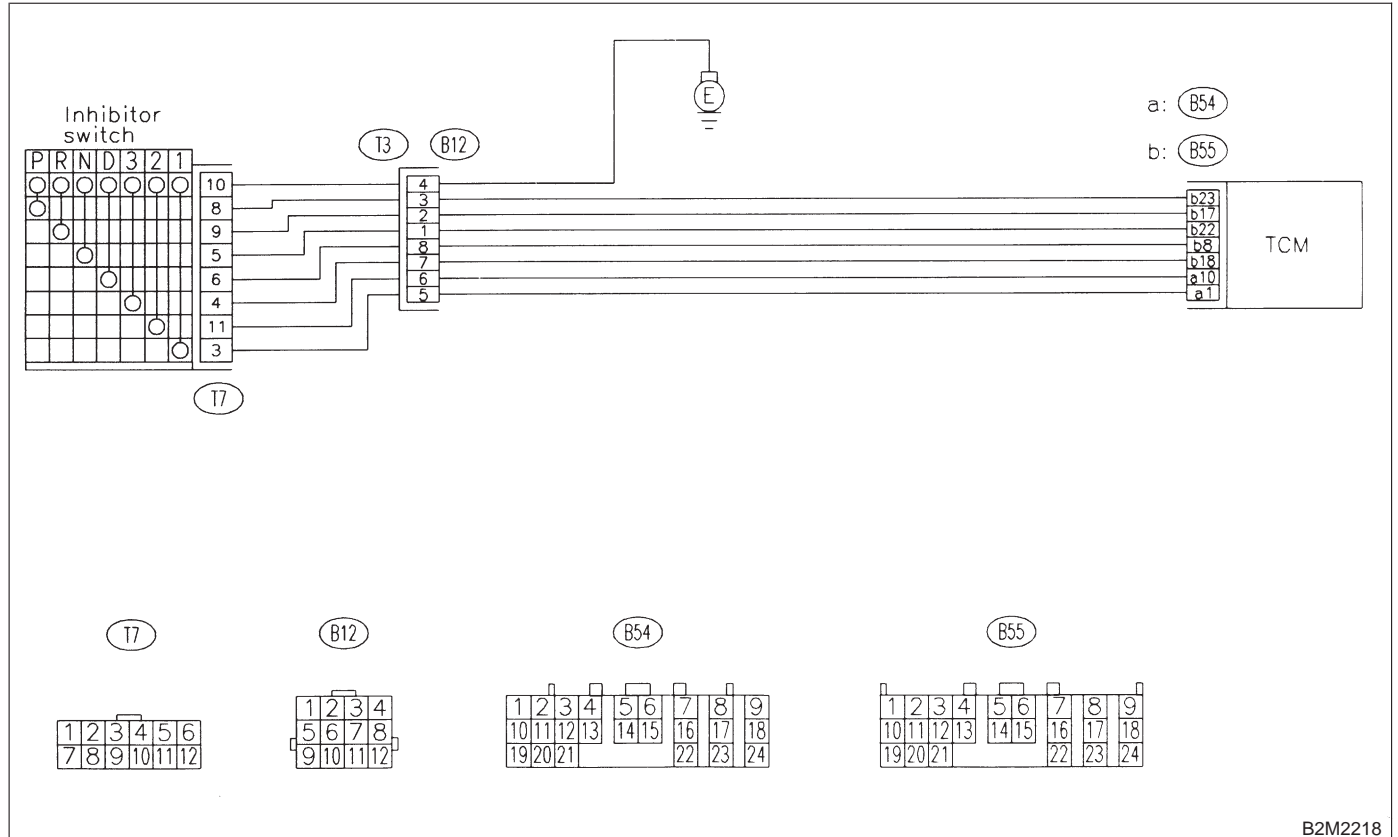

## 3-2 [T9U1] AUTOMATIC TRANSMISSION AND DIFFERENTIAL

### 9. Diagnostic Chart with Select Monitor

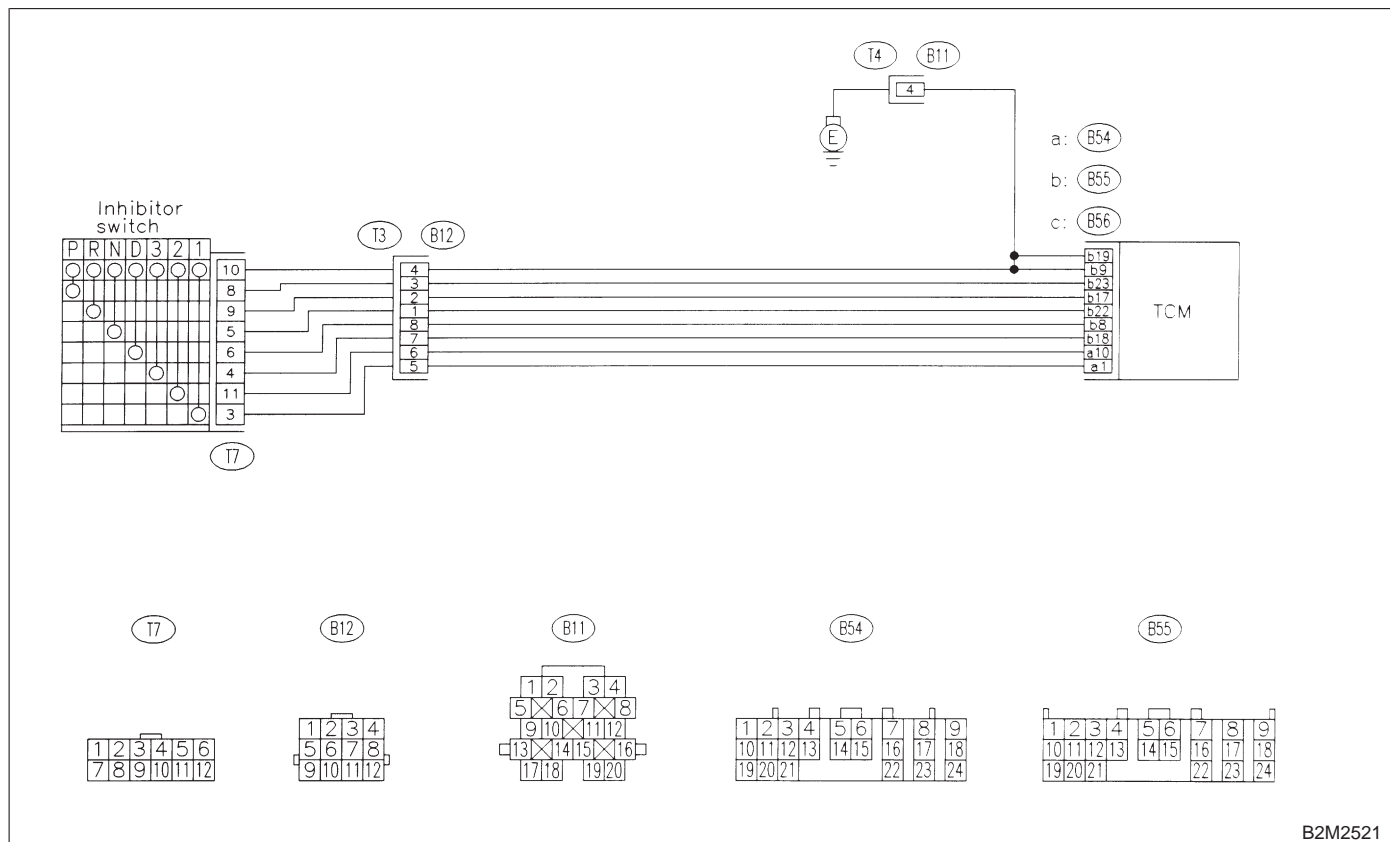

B2M2521

#### 9U1 : CHECK "P" RANGE SWITCH.

**CHECK** : When "P" range is selected, does LED light up?

**YES** : Go to step 9U2.

**NO** : Go to step 9U3.

#### 9U2 : CHECK "N" RANGE SWITCH.

**CHECK** : When the "N" range is selected, does LED light up?

**YES** : Go to step "R" RANGE SWITCH. <Ref. to 3-2 [T9V0].>

**NO** : Go to step 9U5.

#### 9U3 : CHECK HARNESS CONNECTOR BETWEEN TCM AND INHIBITOR SWITCH.

- 1) Turn ignition switch to OFF.
- 2) Disconnect connectors from TCM and inhibitor switch.
- 3) Measure resistance of harness between TCM and inhibitor switch connector.

**Connector & terminal**  
(B55) No. 23 — (T7) No. 8:

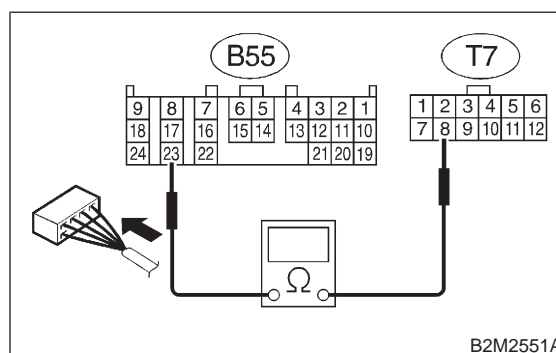

B2M2551A

**CHECK** : Is the resistance less than 1 Ω?

**YES** : Go to step 9U4.

**NO** : Repair open circuit in harness between TCM and inhibitor switch connector, and poor contact in coupling connector.

**9U4 : CHECK HARNESS CONNECTOR BETWEEN TCM AND INHIBITOR SWITCH.**

Measure resistance of harness between inhibitor switch connector and chassis ground.

**Connector & terminal**  
**(T7) No. 10 — (B55) No. 9:**

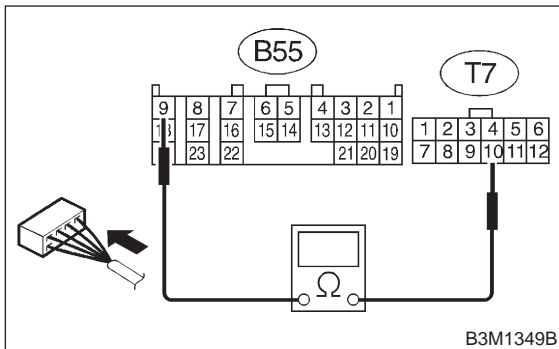

- CHECK** : *Is the resistance less than 1 Ω?*
- YES** : Go to step **9U7**.
- NO** : Repair open circuit in harness between TCM and inhibitor switch connector, and poor contact in coupling connector.

**9U5 : CHECK HARNESS CONNECTOR BETWEEN TCM AND INHIBITOR SWITCH.**

- 1) Turn ignition switch to OFF.
- 2) Disconnect connectors from TCM and inhibitor switch.
- 3) Measure resistance of harness between TCM and inhibitor switch connector.

**Connector & terminal**  
**(B55) No. 22 — (T7) No. 5:**

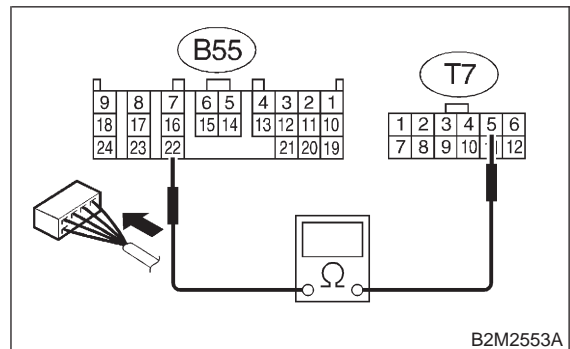

- CHECK** : *Is the resistance less than 1 Ω?*
- YES** : Go to step **9U6**.
- NO** : Repair open circuit in harness between TCM and inhibitor switch connector, and poor contact in coupling connector.

## 3-2 [T9U6] AUTOMATIC TRANSMISSION AND DIFFERENTIAL

### 9. Diagnostic Chart with Select Monitor

#### 9U6 : CHECK HARNESS CONNECTOR BETWEEN TCM AND INHIBITOR SWITCH.

Measure resistance of harness between inhibitor switch connector chassis ground.

##### Connector & terminal

(T7) No. 10 — (B55) No. 9:

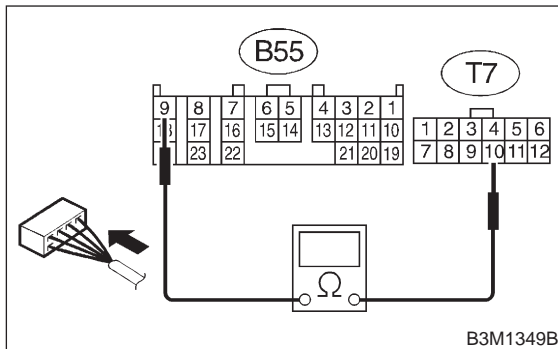

- CHECK** : Is the resistance less than 1 Ω?
- YES** : Go to step 9U8.
- NO** : Repair open circuit in harness between TCM and inhibitor switch connector, and poor contact in coupling connector.

#### 9U7 : CHECK HARNESS CONNECTOR BETWEEN TCM AND INHIBITOR SWITCH.

Measure resistance of harness between TCM and chassis ground.

##### Connector & terminal

(B55) No. 23 — Chassis ground:

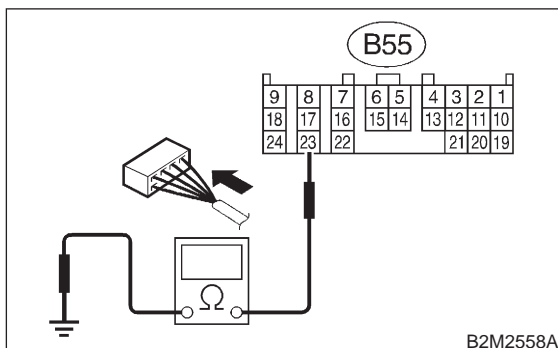

- CHECK** : Is the resistance more than 1 MΩ?
- YES** : Go to step 9U9.
- NO** : Repair ground short circuit in harness between TCM and inhibitor switch connector.

#### 9U8 : CHECK HARNESS CONNECTOR BETWEEN TCM AND INHIBITOR SWITCH.

Measure resistance of harness between TCM and chassis ground.

##### Connector & terminal

(B55) No. 22 — Chassis ground:

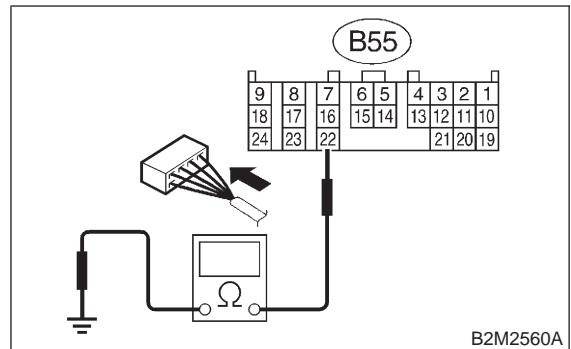

- CHECK** : Is the resistance more than 1 MΩ?
- YES** : Go to step 9U11.
- NO** : Repair ground short circuit in harness between TCM and inhibitor switch connector.

#### 9U9 : CHECK INHIBITOR SWITCH.

Measure resistance between inhibitor switch connector receptacle's terminals.

##### Terminals

No. 8 — No. 10:

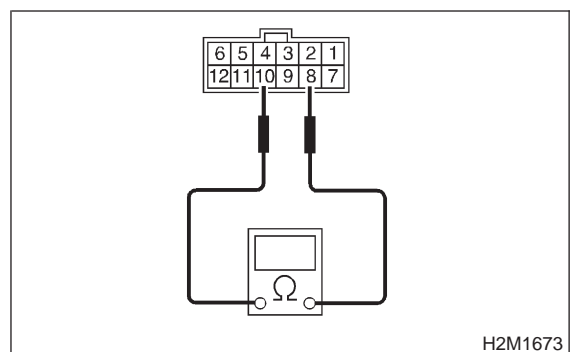

- CHECK** : Is the resistance less than 1 Ω in "P" range?
- YES** : Go to step 9U10.
- NO** : Go to step 9U18.



**9U10 : CHECK INHIBITOR SWITCH.**

Measure resistance between inhibitor switch connector receptacle's terminals.

**Terminals**

**No. 8 — No. 10:**

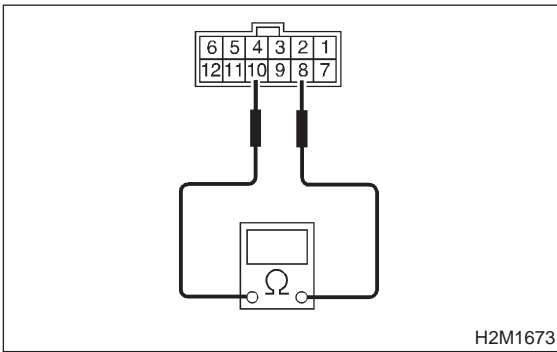

- CHECK** : *Is the resistance more than 1 MΩ in other ranges?*
- YES** : Go to step **9U13**.
- NO** : Go to step **9U18**.

**9U11 : CHECK INHIBITOR SWITCH.**

Measure resistance between inhibitor switch connector receptacle's terminals.

**Terminals**

**No. 5 — No. 10:**

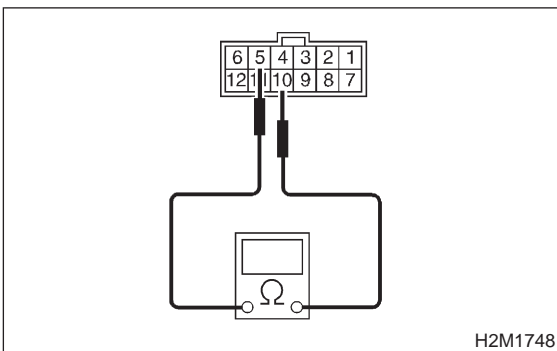

- CHECK** : *Is the resistance less than 1 Ω in "N" range?*
- YES** : Go to step **9U12**.
- NO** : Go to step **9U18**.

**9U12 : CHECK INHIBITOR SWITCH.**

Measure resistance between inhibitor switch connector receptacle's terminals.

**Terminals**

**No. 5 — No. 10:**

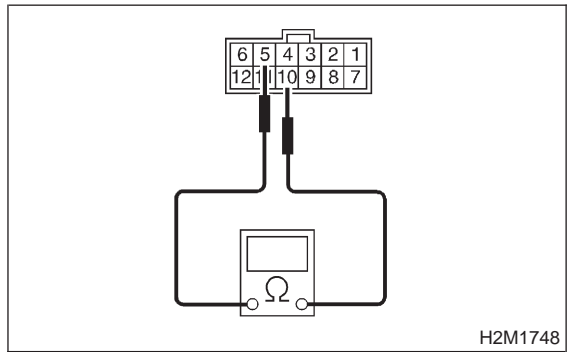

- CHECK** : *Is the resistance more than 1 MΩ in other ranges?*
- YES** : Go to step **9U15**.
- NO** : Go to step **9U18**.

**9U13 : CHECK INPUT SIGNAL FOR TCM.**

- 1) Turn ignition switch to OFF.
- 2) Connect connector to TCM and inhibitor switch.
- 3) Turn ignition switch to ON.
- 4) Measure voltage between TCM and chassis ground.

**Connector & terminal**

**(B55) No. 23 (+) — Chassis ground (-):**

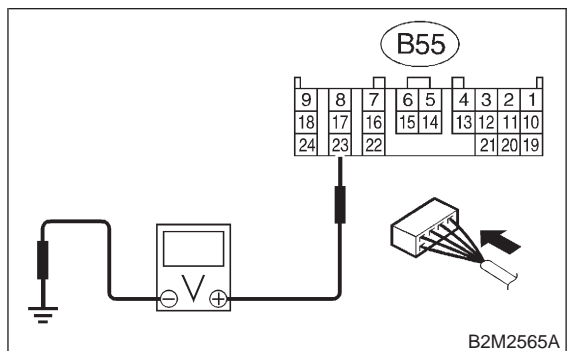

- CHECK** : *Is the voltage less than 1 V in "P" range?*
- YES** : Go to step **9U14**.
- NO** : Go to step **9U17**.

## 3-2 [T9U14] AUTOMATIC TRANSMISSION AND DIFFERENTIAL

### 9. Diagnostic Chart with Select Monitor

#### 9U14 : CHECK INPUT SIGNAL FOR TCM.

Measure voltage between TCM and chassis ground.

##### Connector & terminal

(B55) No. 23 (+) — Chassis ground (-):

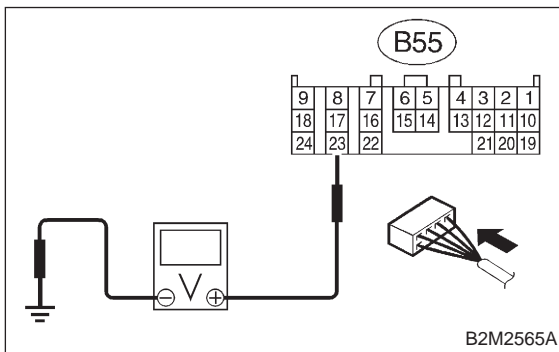

**CHECK** : Is the voltage more than 8 V in other ranges?

**YES** : Go to step 9U17.

**NO** : Go to step 9U18.

#### 9U15 : CHECK INPUT SIGNAL FOR TCM.

- 1) Turn ignition switch to OFF.
- 2) Connect connector to TCM and inhibitor switch.
- 3) Turn ignition switch to ON.
- 4) Measure voltage between TCM and chassis ground.

##### Connector & terminal

(B55) No. 22 (+) — Chassis ground (-):

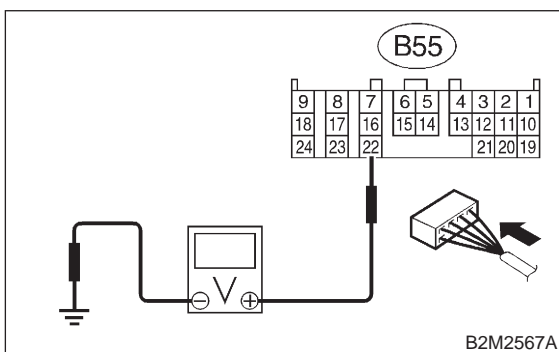

**CHECK** : Is the voltage less than 1 V in "N" range?

**YES** : Go to step 9U16.

**NO** : Go to step 9U17.

#### 9U16 : CHECK INPUT SIGNAL FOR TCM.

Measure voltage between TCM and chassis ground.

##### Connector & terminal

(B55) No. 22 (+) — Chassis ground (-):

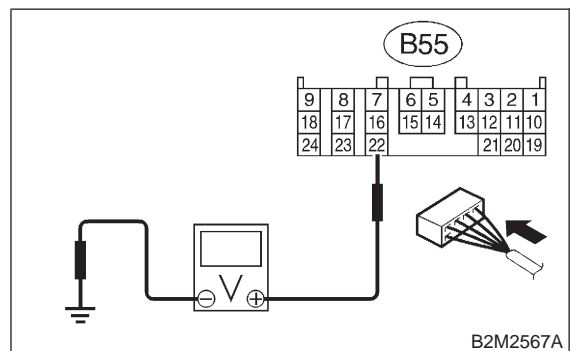

**CHECK** : Is the voltage more than 8 V in other ranges?

**YES** : Go to step 9U17.

**NO** : Go to step 9U18.

#### 9U17 : CHECK POOR CONTACT.

**CHECK** : Is there poor contact in "N/P" range switch circuit?

**YES** : Repair poor contact.

**NO** : Replace TCM. <Ref. to 3-2 [W22A0].>

#### 9U18 : CHECK SELECTOR CABLE.

**CHECK** : Is there faulty connection in the selector cable?

**YES** : Repair connection of selector cable.

**NO** : Replace inhibitor switch. <Ref. to 3-2 [W2C0].>

**V: CHECK "R" RANGE SWITCH.**

**DIAGNOSIS:**

Input signal circuit of "R" range is open or shorted.

**WIRING DIAGRAM:**

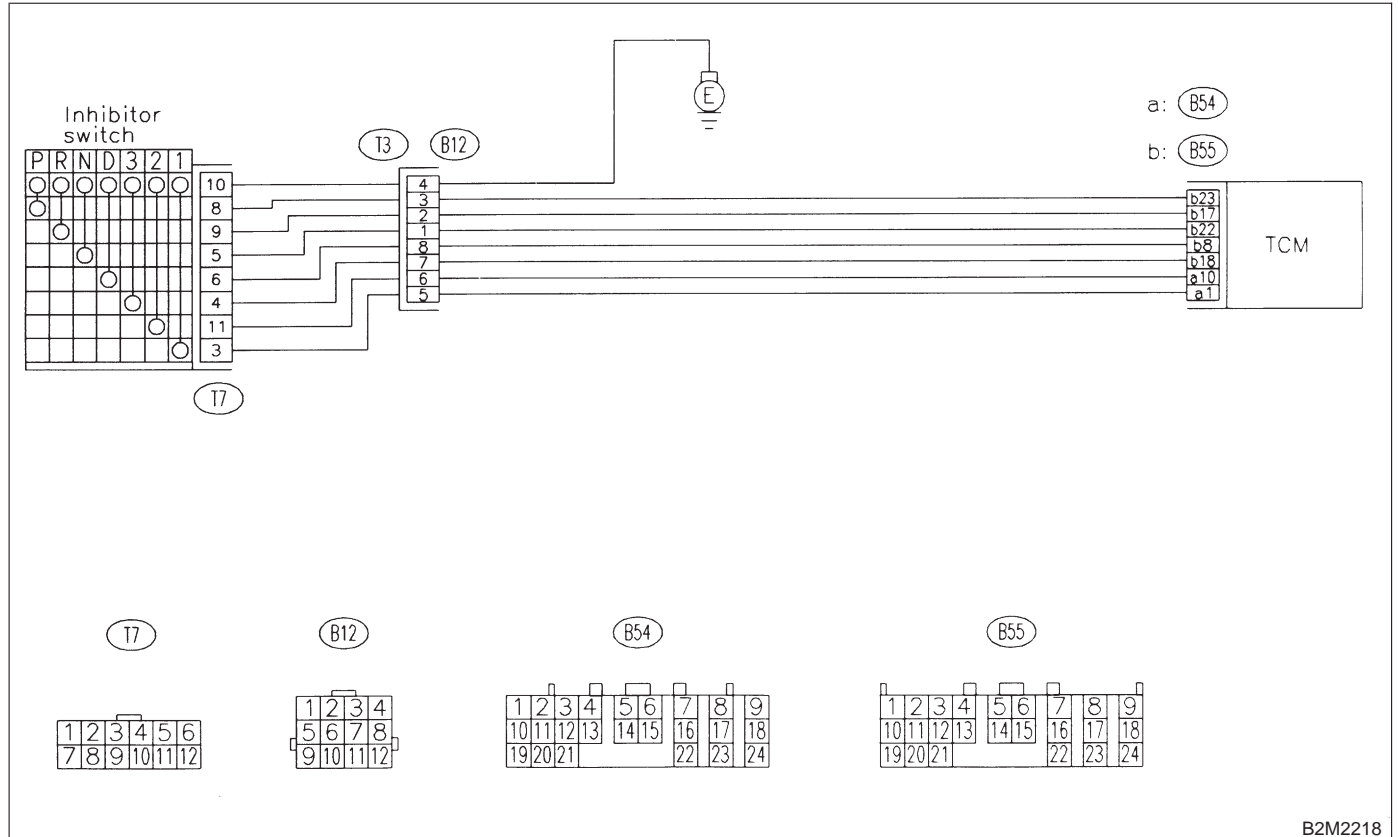

## 3-2 [T9V1] AUTOMATIC TRANSMISSION AND DIFFERENTIAL

### 9. Diagnostic Chart with Select Monitor

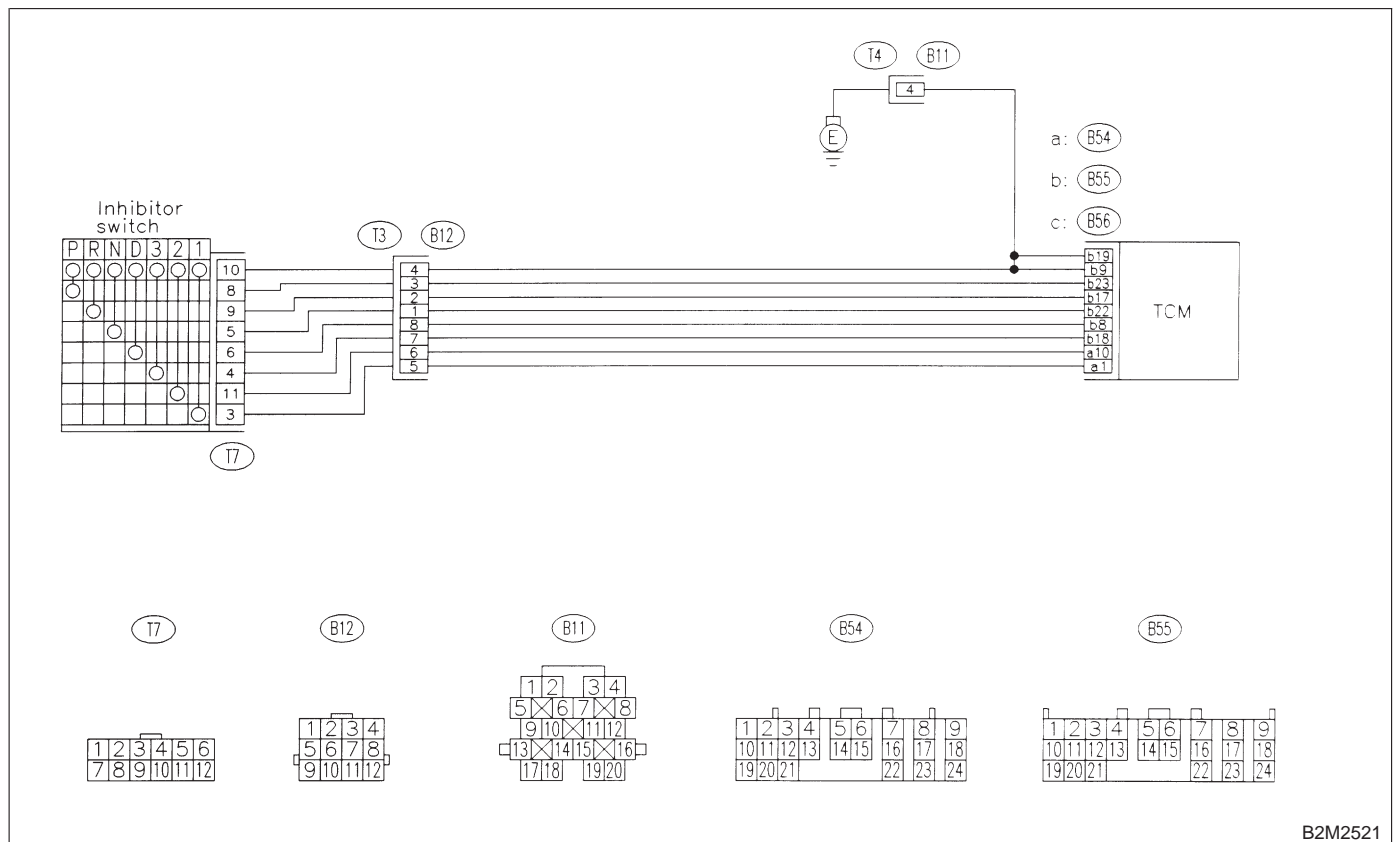

B2M2521

#### 9V1 : CHECK "R" RANGE SWITCH.

- CHECK** : When the "R" range is selected, does LED light up?
- YES** : Go to step "D" RANGE SWITCH. <Ref. to 3-2 [T9W0].>
- NO** : Go to step 9V2.

#### 9V2 : CHECK HARNESS CONNECTOR BETWEEN TCM AND INHIBITOR SWITCH.

- 1) Turn ignition switch to OFF.
- 2) Disconnect connectors from TCM and inhibitor switch.
- 3) Measure resistance of harness between TCM and inhibitor switch connector.

#### Connector & terminal

(B55) No. 17 — (T7) No. 9:

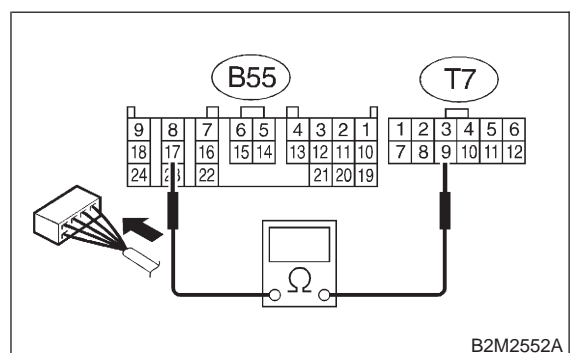

B2M2552A

- CHECK** : Is the resistance less than 1 Ω?
- YES** : Go to step 9V3.
- NO** : Repair open circuit in harness between TCM and inhibitor switch connector, and poor contact in coupling connector.

**9V3 : CHECK HARNESS CONNECTOR BETWEEN TCM AND INHIBITOR SWITCH.**

Measure resistance of harness between inhibitor switch connector and chassis ground.

**Connector & terminal**  
**(T7) No. 10 — (B55) No. 9:**

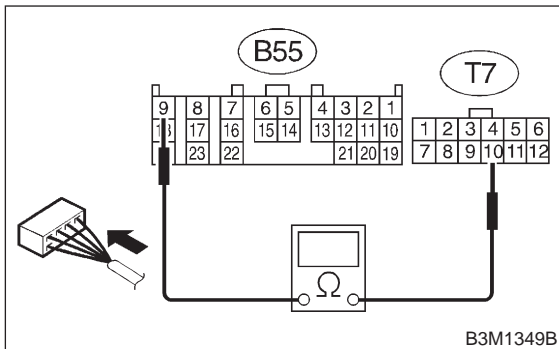

- CHECK** : Is the resistance less than 1 Ω?
- YES** : Go to step 9V4.
- NO** : Repair open circuit in harness between TCM and inhibitor switch connector, and poor contact in coupling connector.

**9V4 : CHECK HARNESS CONNECTOR BETWEEN TCM AND INHIBITOR SWITCH.**

Measure resistance of harness between TCM and chassis ground.

**Connector & terminal**  
**(B55) No. 17 — Chassis ground:**

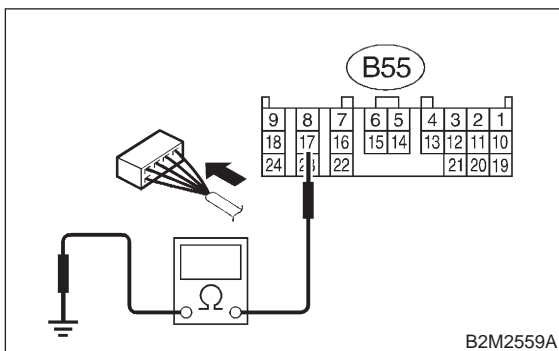

- CHECK** : Is the resistance more than 1 MΩ?
- YES** : Go to step 9V5.
- NO** : Repair ground short circuit in harness between TCM and inhibitor switch connector.

**9V5 : CHECK INHIBITOR SWITCH.**

Measure resistance between inhibitor switch connector receptacle's terminals.

**Terminals**  
**No. 9 — No. 10:**

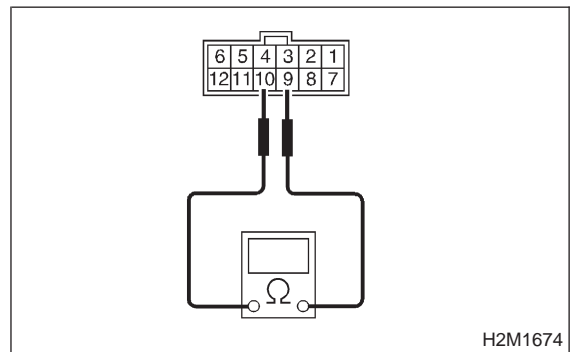

- CHECK** : Is the resistance less than 1 Ω in "R" range?
- YES** : Go to step 9V6.
- NO** : Go to step 9V10.

**9V6 : CHECK INHIBITOR SWITCH.**

Measure resistance between inhibitor switch connector receptacle's terminals.

**Terminals**  
**No. 9 — No. 10:**

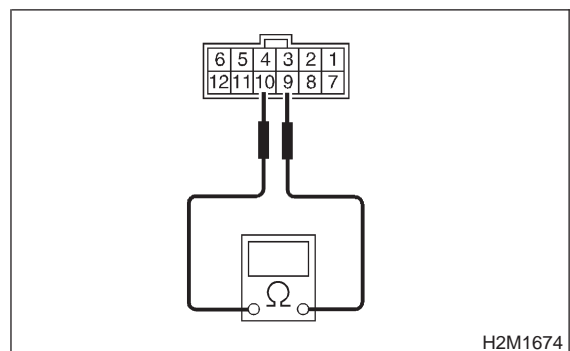

- CHECK** : Is the resistance more than 1 MΩ in other ranges?
- YES** : Go to step 9V7.
- NO** : Go to step 9V10.

## 3-2 [T9V7] AUTOMATIC TRANSMISSION AND DIFFERENTIAL

### 9. Diagnostic Chart with Select Monitor

#### 9V7 : CHECK INPUT SIGNAL FOR TCM.

- 1) Turn ignition switch to OFF.
- 2) Connect connector to TCM and inhibitor switch.
- 3) Turn ignition switch to ON.
- 4) Measure voltage between TCM and chassis ground.

##### Connector & terminal

(B55) No. 17 (+) — Chassis ground (-):

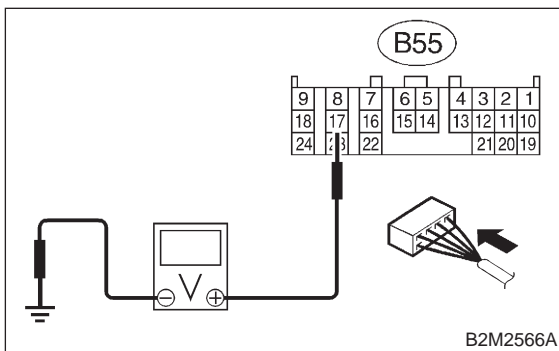

**CHECK** : Is the voltage less than 1 V in “R” range?

**YES** : Go to step 9V8.

**NO** : Go to step 9V9.

#### 9V8 : CHECK INPUT SIGNAL FOR TCM.

Measure voltage between TCM and chassis ground.

##### Connector & terminal

(B55) No. 17 (+) — Chassis ground (-):

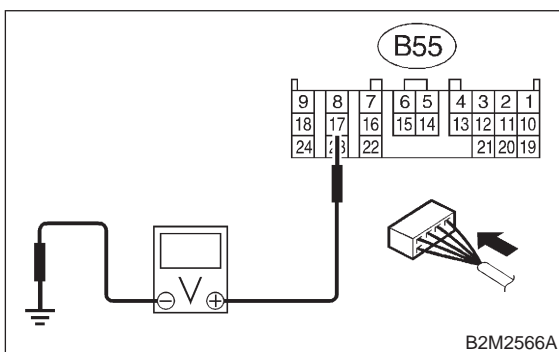

**CHECK** : Is the voltage more than 95 V in other ranges?

**YES** : Go to step 9V9.

**NO** : Go to step 9V10.

#### 9V9 : CHECK POOR CONTACT.

**CHECK** : Is there poor contact in “R” range switch circuit?

**YES** : Repair poor contact.

**NO** : Replace TCM. <Ref. to 3-2 [W22A0].>

#### 9V10 : CHECK SELECTOR CABLE.

**CHECK** : Is there faulty connection in the selector cable?

**YES** : Repair connection of selector cable.

**NO** : Replace inhibitor switch. <Ref. to 3-2 [W2C0].>

**W: CHECK "D" RANGE SWITCH.**

**DIAGNOSIS:**

Input signal circuit of "D" range is open or shorted.

**TROUBLE SYMPTOM:**

Shift characteristics are erroneous.

**WIRING DIAGRAM:**

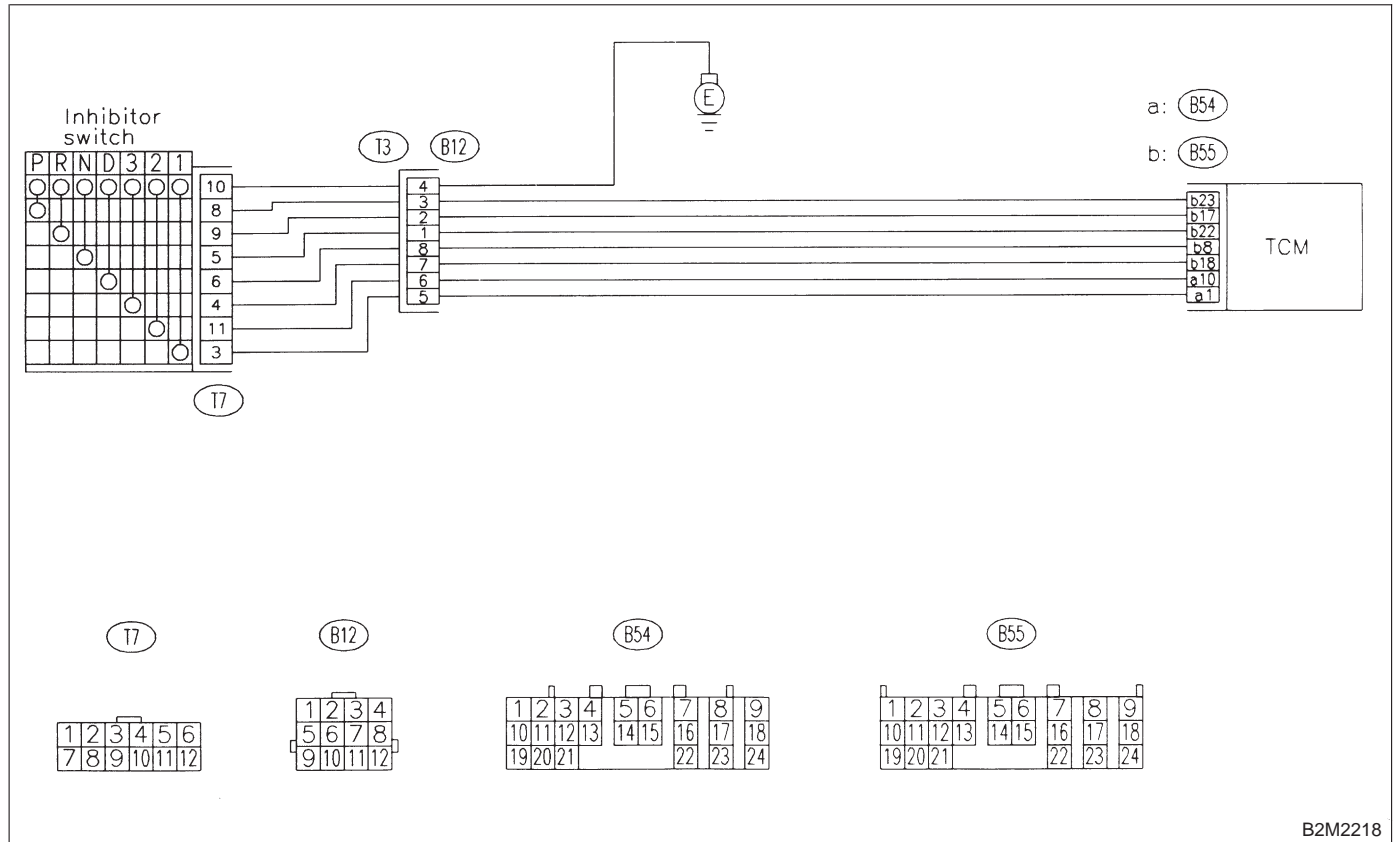

## 3-2 [T9W1] AUTOMATIC TRANSMISSION AND DIFFERENTIAL

### 9. Diagnostic Chart with Select Monitor

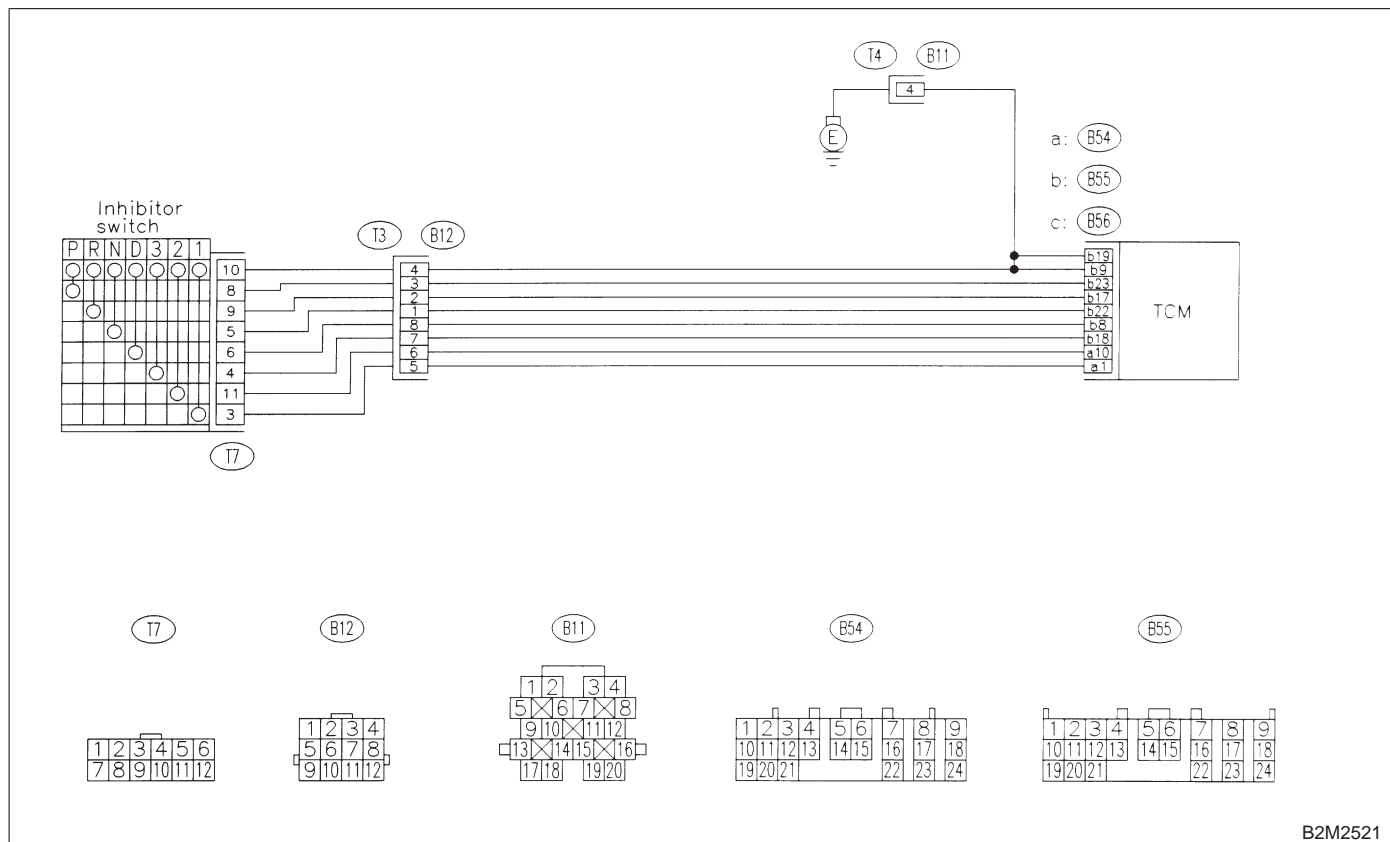

#### 9W1 : CHECK "D" RANGE SWITCH.

- CHECK** : When the "D" range is selected, does LED light up?
- YES** : Go to step "3" RANGE SWITCH. <Ref. to 3-2 [T9X0].>
- NO** : Go to step 9W2.

#### 9W2 : CHECK HARNESS CONNECTOR BETWEEN TCM AND INHIBITOR SWITCH.

- 1) Turn ignition switch to OFF.
- 2) Disconnect connectors from TCM and inhibitor switch.
- 3) Measure resistance of harness between TCM and inhibitor switch connector.

#### Connector & terminal (B55) No. 8 — (T7) No. 6:

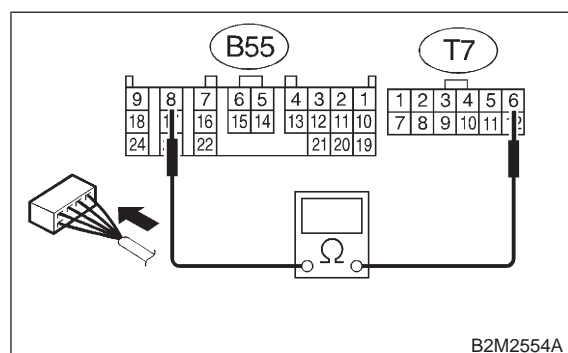

- CHECK** : Is the resistance less than 1 Ω?
- YES** : Go to step 9W3.
- NO** : Repair open circuit in harness between TCM and inhibitor switch connector, and poor contact in coupling connector.



**9W3 : CHECK HARNESS CONNECTOR BETWEEN TCM AND INHIBITOR SWITCH.**

Measure resistance of harness between inhibitor switch connector and chassis ground.

**Connector & terminal**  
**(T7) No. 10 — (B55) No. 9:**

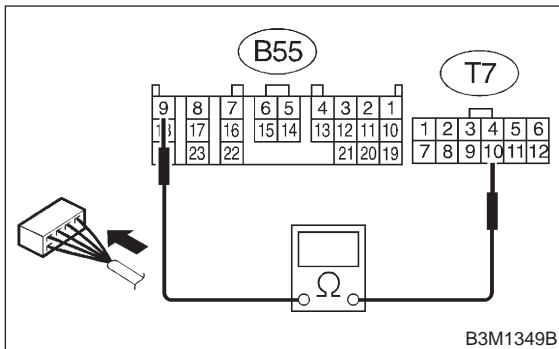

- CHECK** : *Is the resistance less than 1 Ω?*
- YES** : Go to step **9W4**.
- NO** : Repair open circuit in harness between TCM and inhibitor switch connector, and poor contact in coupling connector.

**9W4 : CHECK HARNESS CONNECTOR BETWEEN TCM AND INHIBITOR SWITCH.**

Measure resistance of harness between TCM and chassis ground.

**Connector & terminal**  
**(B55) No. 8 — Chassis ground:**

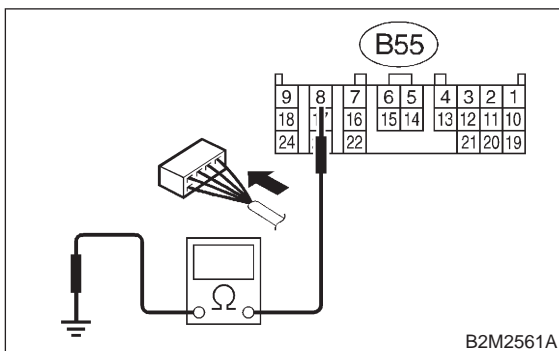

- CHECK** : *Is the resistance more than 1 MΩ?*
- YES** : Go to step **9W5**.
- NO** : Repair ground short circuit in harness between TCM and inhibitor switch connector.

**9W5 : CHECK INHIBITOR SWITCH.**

Measure resistance between inhibitor switch connector receptacle's terminals.

**Terminals**  
**No. 6 — No. 10:**

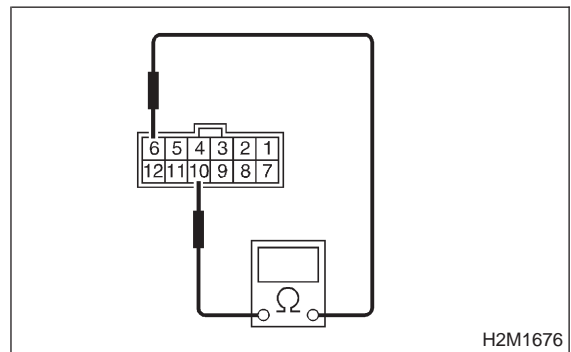

- CHECK** : *Is the resistance less than 1 Ω in "D" range?*
- YES** : Go to step **9W6**.
- NO** : Go to step **9W10**.

**9W6 : CHECK INHIBITOR SWITCH.**

Measure resistance between inhibitor switch connector receptacle's terminals.

**Terminals**  
**No. 6 — No. 10:**

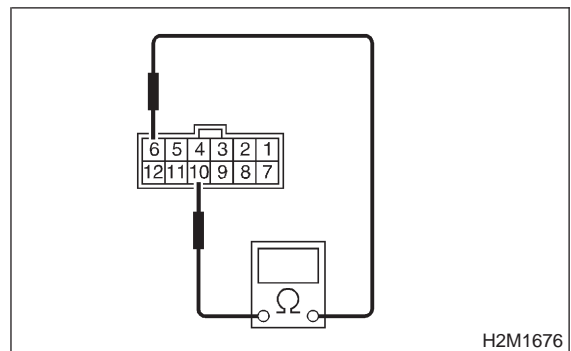

- CHECK** : *Is the resistance more than 1 MΩ in other ranges?*
- YES** : Go to step **9W7**.
- NO** : Go to step **9W10**.

## 3-2 [T9W7] AUTOMATIC TRANSMISSION AND DIFFERENTIAL

### 9. Diagnostic Chart with Select Monitor

#### 9W7 : CHECK INPUT SIGNAL FOR TCM.

- 1) Turn ignition switch to OFF.
- 2) Connect connector to TCM and inhibitor switch.
- 3) Turn ignition switch to ON.
- 4) Measure voltage between TCM and chassis ground.

**Connector & terminal**  
(B55) No. 8 (+) — Chassis ground (-):

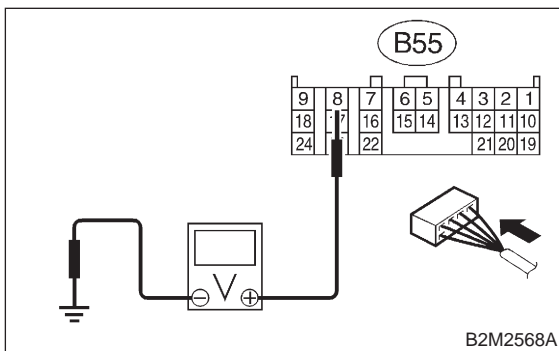

**CHECK** : Is the voltage less than 1 V in “D” range?

**YES** : Go to step 9W8.

**NO** : Go to step 9W9.

#### 9W8 : CHECK INPUT SIGNAL FOR TCM.

Measure voltage between TCM and chassis ground.

**Connector & terminal**  
(B55) No. 8 (+) — Chassis ground (-):

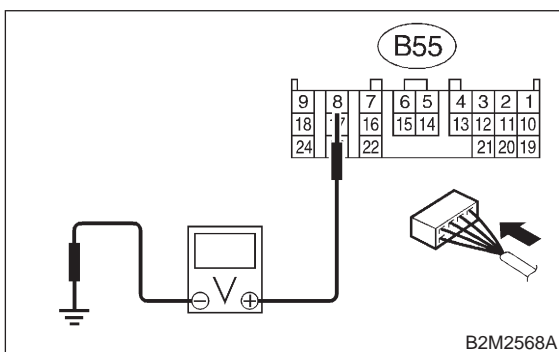

**CHECK** : Is the voltage more than 9.5 V in other ranges?

**YES** : Go to step 9W9.

**NO** : Go to step 9W10.

#### 9W9 : CHECK POOR CONTACT.

**CHECK** : Is there poor contact in “D” range switch circuit?

**YES** : Repair poor contact.

**NO** : Replace TCM. <Ref. to 3-2 [W22A0].>

#### 9W10 : CHECK SELECTOR CABLE.

**CHECK** : Is there faulty connection in the selector cable?

**YES** : Repair connection of selector cable.

**NO** : Replace inhibitor switch. <Ref. to 3-2 [W2C0].>

**X: CHECK "3" RANGE SWITCH.**

**DIAGNOSIS:**

Input signal circuit of "3" range is open or shorted.

**TROUBLE SYMPTOM:**

- Shift characteristics are erroneous.
- Engine brake is not effected when selector lever is in "3" range.

**WIRING DIAGRAM:**

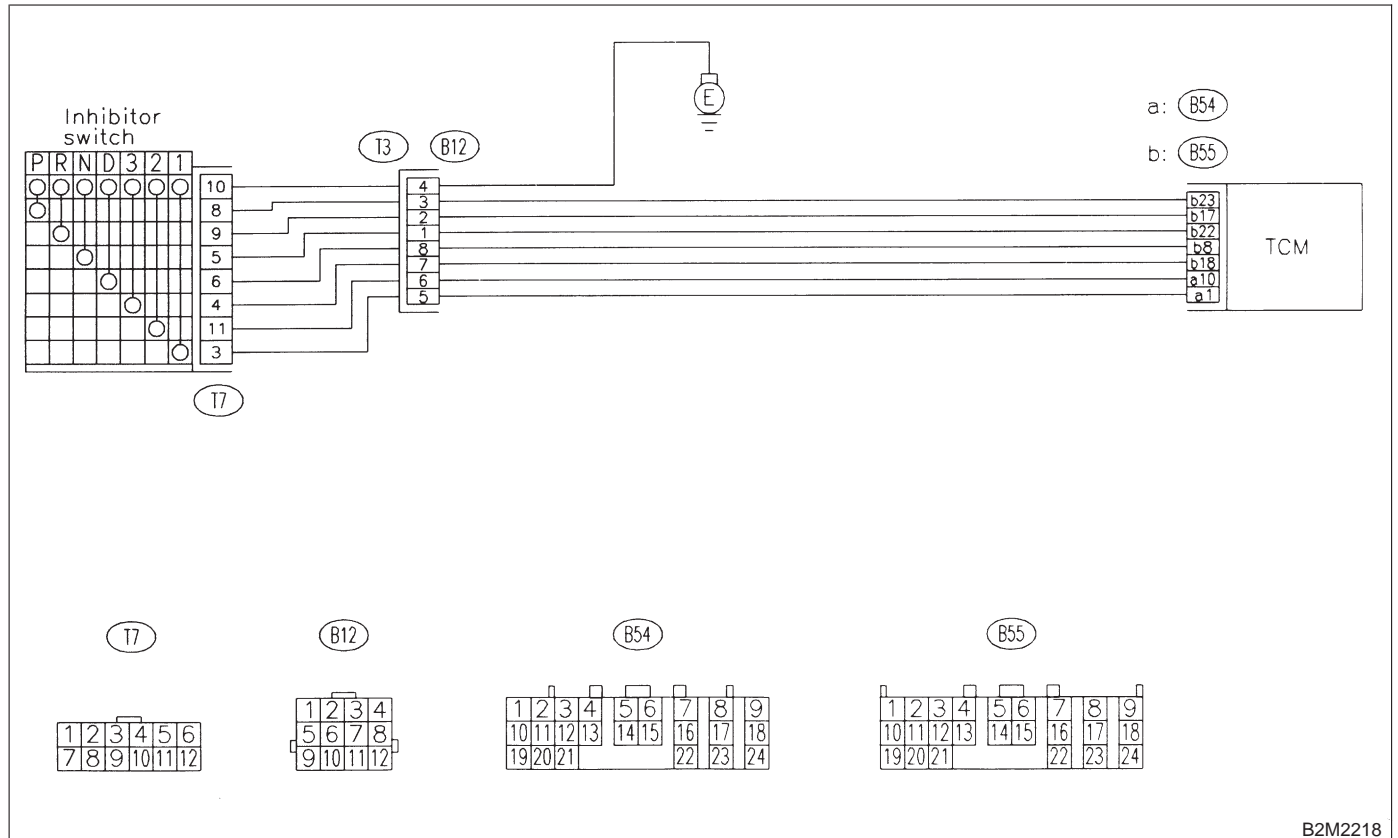

B2M2218

### 3-2 [T9X1] AUTOMATIC TRANSMISSION AND DIFFERENTIAL

#### 9. Diagnostic Chart with Select Monitor

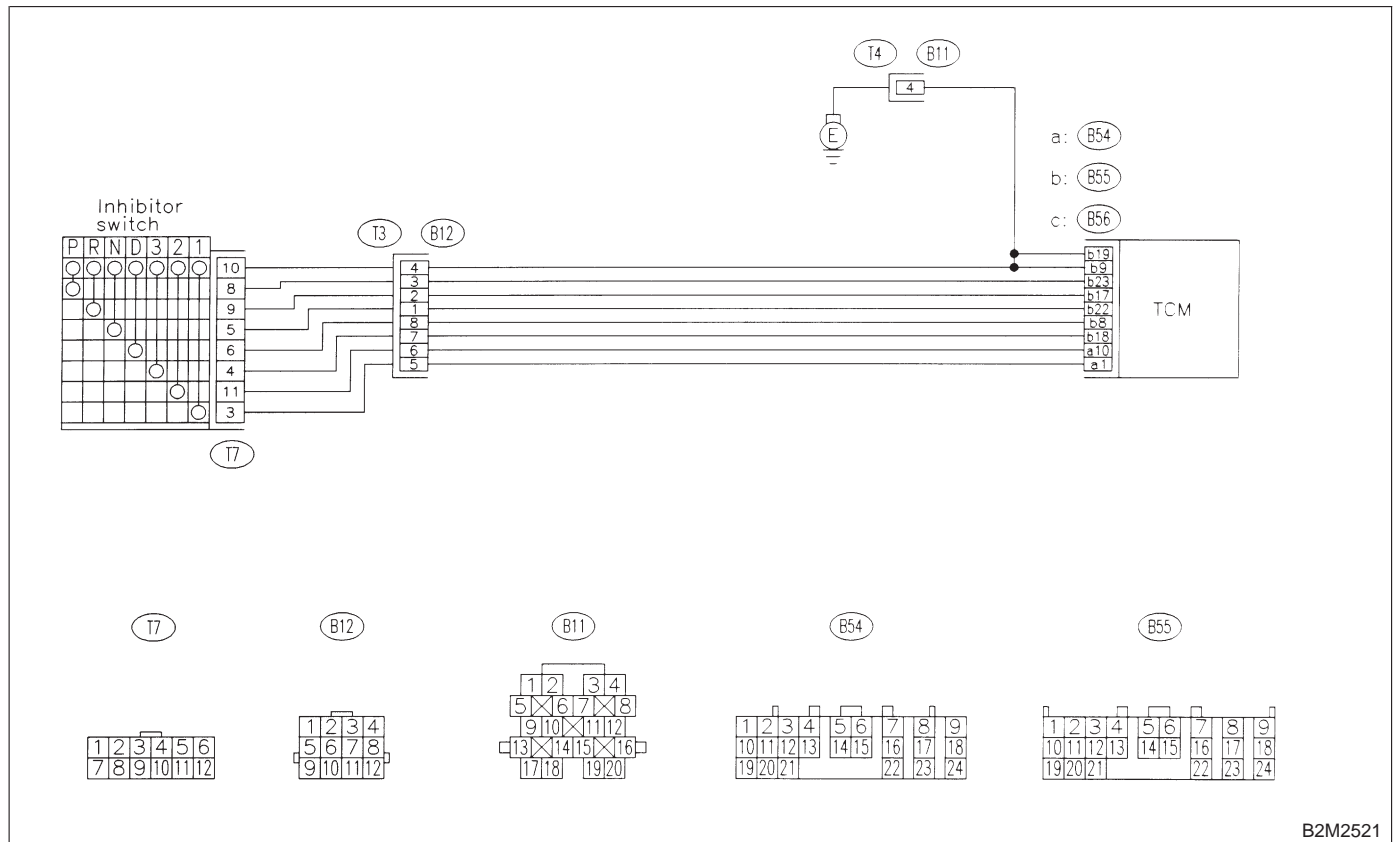

B2M2521

#### 9X1 : CHECK "3" RANGE SWITCH.

- CHECK** : When the "3" range is selected, does LED light up?
- YES** : Go to step "2" RANGE SWITCH. <Ref. to 3-2 [T9Y0].>
- NO** : Go to step 9X2.

#### 9X2 : CHECK HARNESS CONNECTOR BETWEEN TCM AND INHIBITOR SWITCH.

- 1) Turn ignition switch to OFF.
- 2) Disconnect connector from TCM and inhibitor switch.
- 3) Measure resistance of harness between TCM and inhibitor switch connector.

**Connector & terminal (B55) No. 18 — (T7) No. 4:**

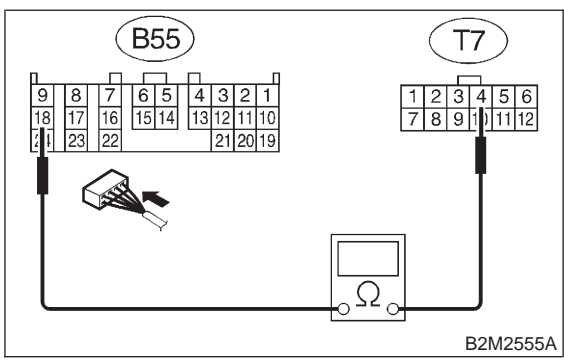

- CHECK** : Is the resistance less than 1 Ω?
- YES** : Go to step 9X3.
- NO** : Repair open circuit in harness between TCM and inhibitor switch connector, and poor contact in coupling connector.

**9X3 : CHECK HARNESS CONNECTOR BETWEEN TCM AND INHIBITOR SWITCH.**

Measure resistance of harness between inhibitor switch connector and chassis ground.

**Connector & terminal**  
**(T7) No. 10 — (B55) No. 9:**

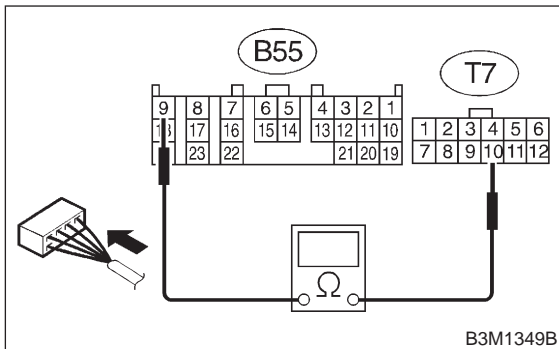

- CHECK** : *Is the resistance less than 1 Ω?*
- YES** : Go to step **9X4**.
- NO** : Repair open circuit in harness between TCM and inhibitor switch connector, and poor contact in coupling connector.

**9X4 : CHECK HARNESS CONNECTOR BETWEEN TCM AND INHIBITOR SWITCH.**

Measure resistance of harness between TCM and chassis ground.

**Connector & terminal**  
**(B55) No. 18 — Chassis ground:**

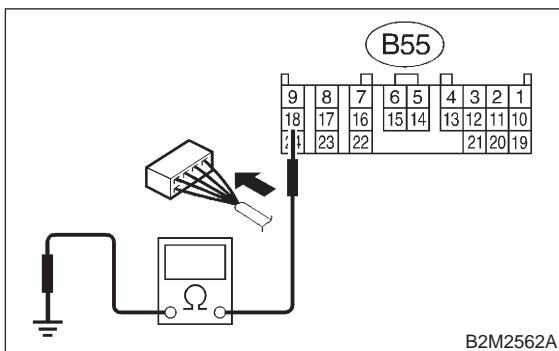

- CHECK** : *Is the resistance more than 1 MΩ?*
- YES** : Go to step **9X5**.
- NO** : Repair ground short circuit in harness between TCM and inhibitor switch connector.

**9X5 : CHECK INHIBITOR SWITCH.**

Measure resistance between inhibitor switch connector receptacle's terminals.

**Terminals**  
**No. 4 — No. 10:**

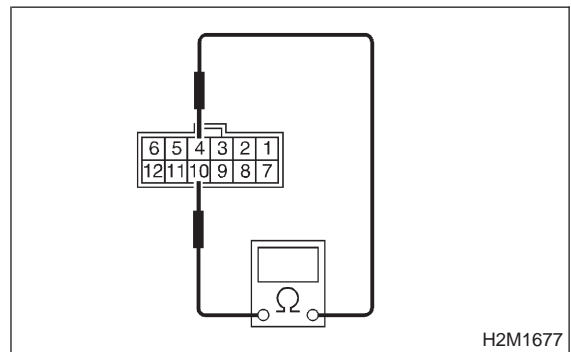

- CHECK** : *Is the resistance less than 1 Ω in “3” range?*
- YES** : Go to step **9X6**.
- NO** : Go to step **9X7**.

**9X6 : CHECK INHIBITOR SWITCH.**

Measure resistance between inhibitor switch connector receptacle's terminals.

**Terminals**  
**No. 4 — No. 10:**

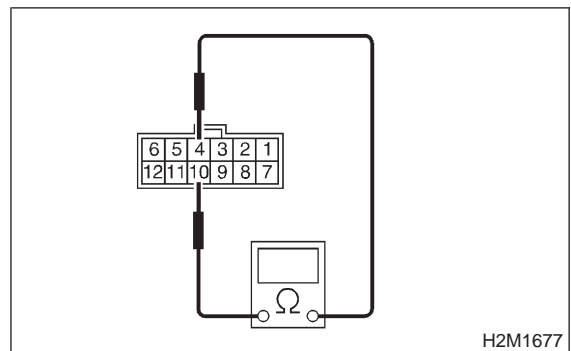

- CHECK** : *Is the resistance more than 1 MΩ in other ranges?*
- YES** : Go to step **9X7**.
- NO** : Go to step **9X10**.

## 3-2 [T9X7] AUTOMATIC TRANSMISSION AND DIFFERENTIAL

### 9. Diagnostic Chart with Select Monitor

#### 9X7 : CHECK INPUT SIGNAL FOR TCM.

- 1) Turn ignition switch to OFF.
- 2) Connect connector to TCM and inhibitor switch.
- 3) Turn ignition switch to ON.
- 4) Measure voltage between TCM and chassis ground.

**Connector & terminal**  
**(B55) No. 18 (+) — Chassis ground (-):**

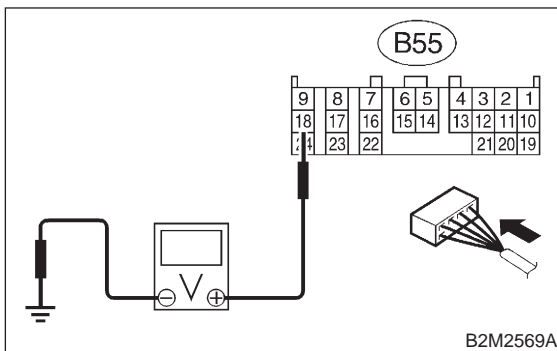

**CHECK** : *Is the voltage less than 1 V in “3” range?*

**YES** : Go to step 9X8.

**NO** : Go to step 9X9.

#### 9X8 : CHECK INPUT SIGNAL FOR TCM.

Measure voltage between TCM and chassis ground.

**Connector & terminal**  
**(B55) No. 18 (+) — Chassis ground (-):**

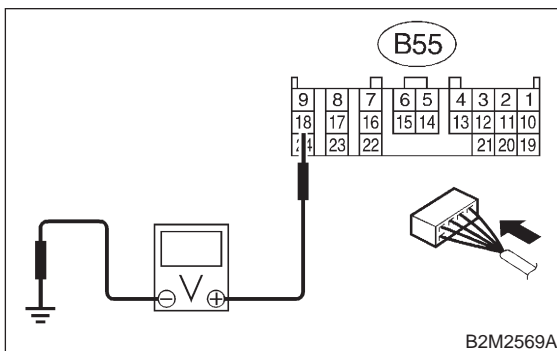

**CHECK** : *Is the voltage more than 9.5 V in other ranges?*

**YES** : Go to step 9X9.

**NO** : Go to step 9X10.

#### 9X9 : CHECK POOR CONTACT.

**CHECK** : *Is there poor contact in “3” range switch circuit?*

**YES** : Repair poor contact.

**NO** : Replace TCM. <Ref. to 3-2 [W22A0].>

#### 9X10 : CHECK SELECTOR CABLE.

**CHECK** : *Is there faulty connection in the selector cable?*

**YES** : Repair connection of selector cable.

**NO** : Replace inhibitor switch. <Ref. to 3-2 [W2C0].>

**Y: CHECK "2" RANGE SWITCH.**

**DIAGNOSIS:**

Input signal circuit of "2" range is open or shorted.

**TROUBLE SYMPTOM:**

- Shift characteristics are erroneous.
- Engine brake is not effected when selector lever is in "2" range.

**WIRING DIAGRAM:**

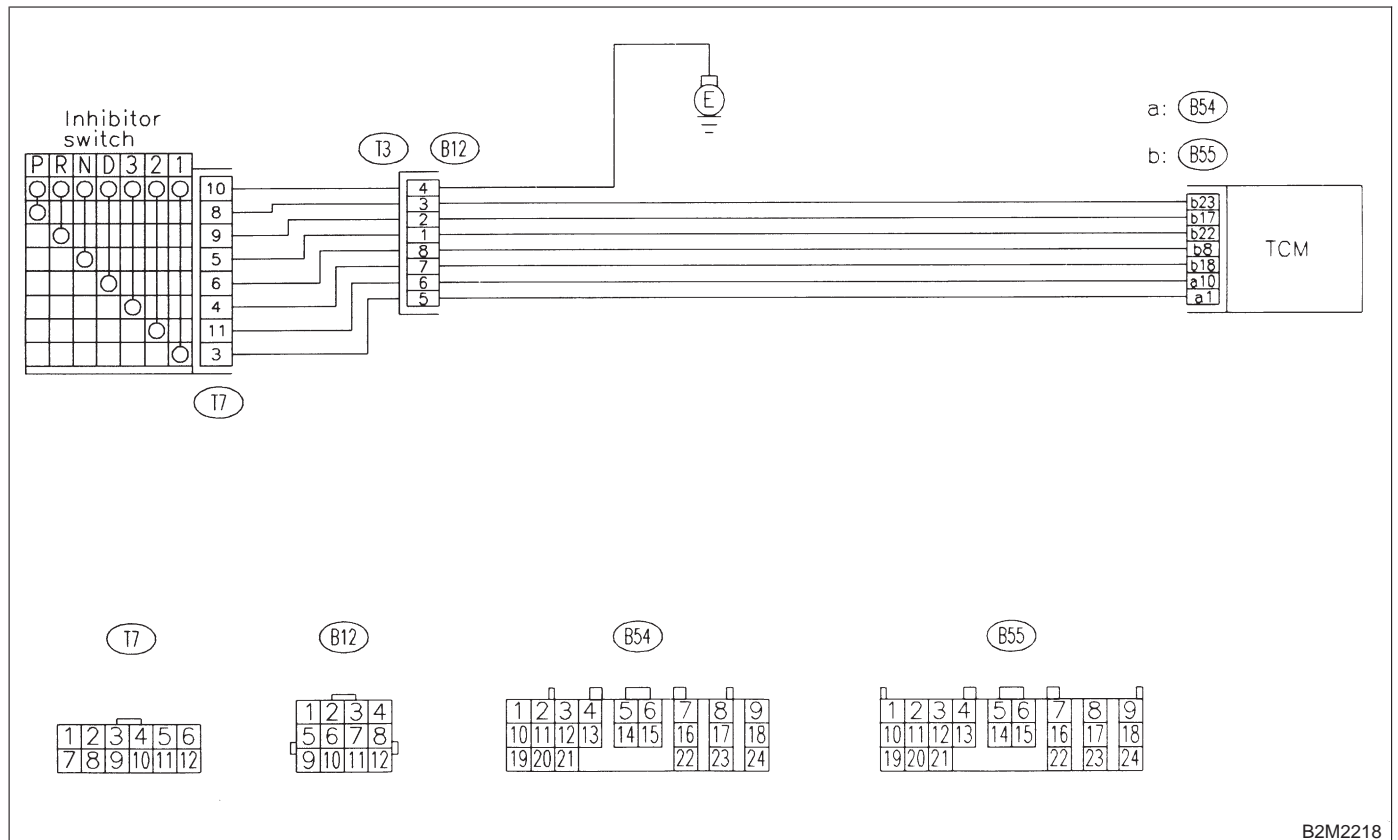

B2M2218

## 3-2 [T9Y1] AUTOMATIC TRANSMISSION AND DIFFERENTIAL

### 9. Diagnostic Chart with Select Monitor

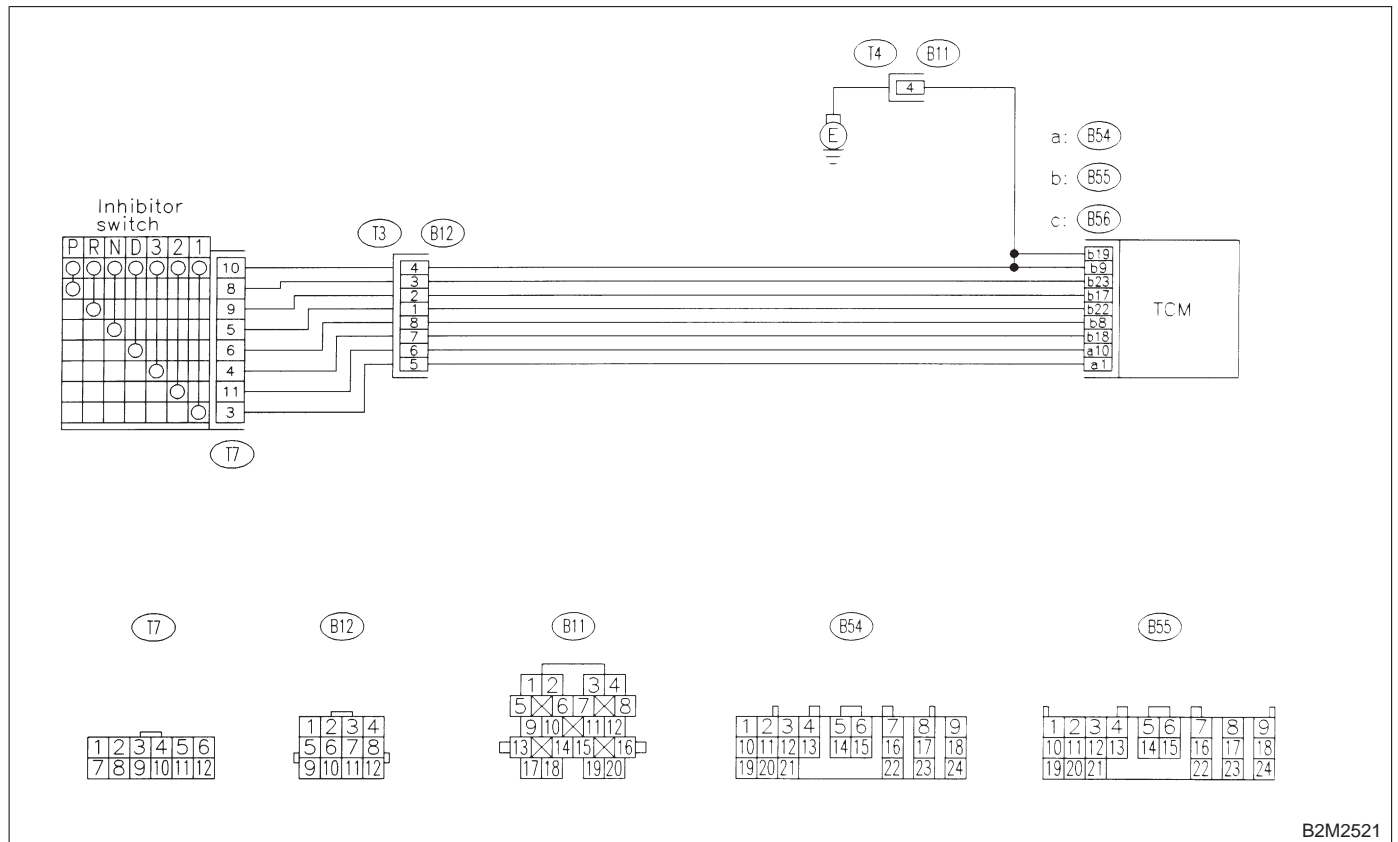

B2M2521

#### 9Y1 : CHECK "2" RANGE SWITCH.

- CHECK** : When the "2" range is selected, does LED light up?
- YES** : Go to step "1" RANGE SWITCH. <Ref. to 3-2 [T9Z0].>
- NO** : Go to step 9Y2.

#### 9Y2 : CHECK HARNESS CONNECTOR BETWEEN TCM AND INHIBITOR SWITCH.

- 1) Turn ignition switch to OFF.
- 2) Disconnect connector from TCM and inhibitor switch.
- 3) Measure resistance of harness between TCM and inhibitor switch connector.

#### Connector & terminal

(B54) No. 10 — (T7) No. 11:

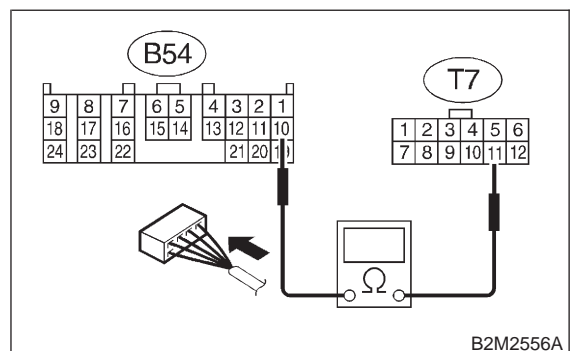

B2M2556A

- CHECK** : Is the resistance less than 1 Ω?
- YES** : Go to step 9Y3.
- NO** : Repair open circuit in harness between TCM and inhibitor switch connector, and poor contact in coupling connector.



**9Y3 : CHECK HARNESS CONNECTOR BETWEEN TCM AND INHIBITOR SWITCH.**

Measure resistance of harness between inhibitor switch connector and chassis ground.

**Connector & terminal**  
**(T7) No. 10 — (B55) No. 9:**

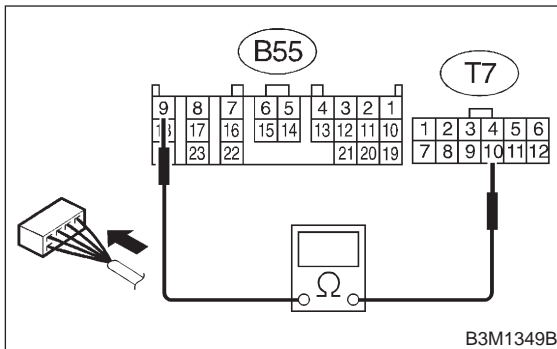

- CHECK** : Is the resistance less than 1 Ω?
- YES** : Go to step 9Y4.
- NO** : Repair open circuit in harness between TCM and inhibitor switch connector, and poor contact in coupling connector.

**9Y4 : CHECK HARNESS CONNECTOR BETWEEN TCM AND INHIBITOR SWITCH.**

Measure resistance of harness between TCM and chassis ground.

**Connector & terminal**  
**(B54) No. 10 — Chassis ground:**

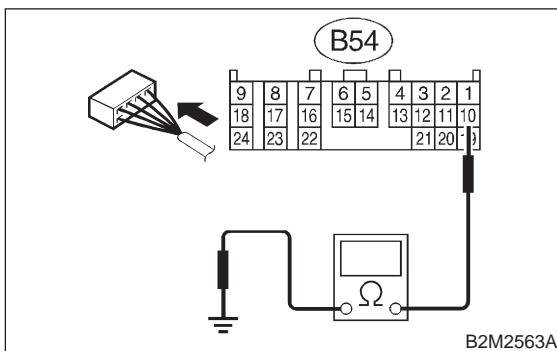

- CHECK** : Is the resistance more than 1 MΩ?
- YES** : Go to step 9Y5.
- NO** : Repair ground short circuit in harness between TCM and inhibitor switch connector.

**9Y5 : CHECK INHIBITOR SWITCH.**

Measure resistance between inhibitor switch connector receptacle's terminals.

**Terminals**  
**No. 11 — No. 10:**

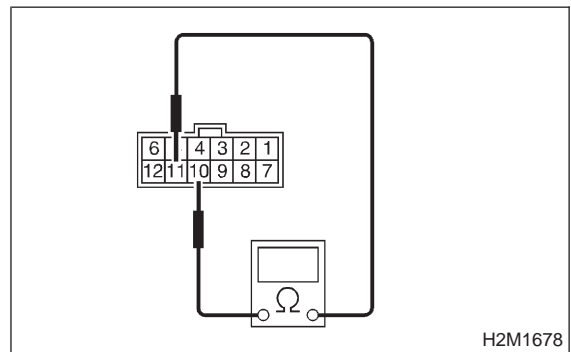

- CHECK** : Is the resistance less than 1 Ω in "2" range?
- YES** : Go to step 9Y6.
- NO** : Go to step 9Y10.

**9Y6 : CHECK INHIBITOR SWITCH.**

Measure resistance between inhibitor switch connector receptacle's terminals.

**Terminals**  
**No. 11 — No. 10:**

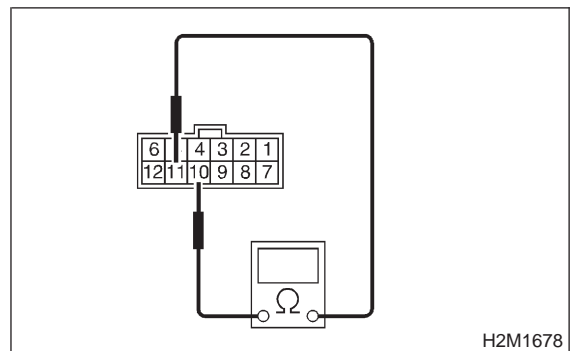

- CHECK** : Is the resistance more than 1 MΩ in other ranges?
- YES** : Go to step 9Y7.
- NO** : Go to step 9Y10.

## 3-2 [T9Y7] AUTOMATIC TRANSMISSION AND DIFFERENTIAL

### 9. Diagnostic Chart with Select Monitor

#### 9Y7 : CHECK INPUT SIGNAL FOR TCM.

- 1) Turn ignition switch to OFF.
- 2) Connect connector to TCM and inhibitor switch.
- 3) Turn ignition switch to ON.
- 4) Measure voltage between TCM and chassis ground.

**Connector & terminal**  
**(B54) No. 10 (+) — Chassis ground (-):**

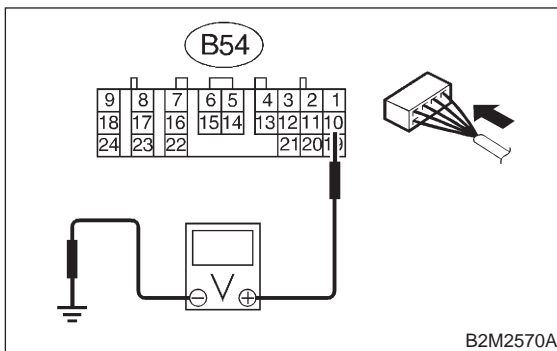

**CHECK** : *Is the voltage less than 1 V in "2" range?*

**YES** : Go to step 9Y8.

**NO** : Go to step 9Y9.

#### 9Y8 : CHECK INPUT SIGNAL FOR TCM.

Measure voltage between TCM and chassis ground.

**Connector & terminal**  
**(B54) No. 10 (+) — Chassis ground (-):**

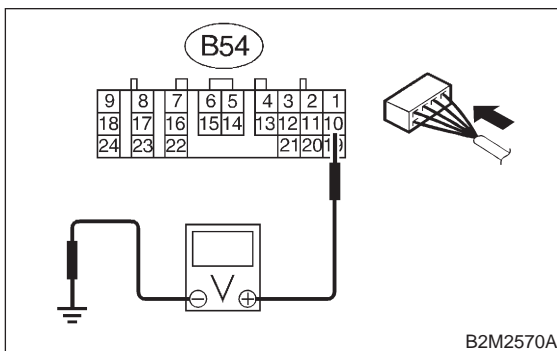

**CHECK** : *Is the voltage more than 9.5 V in other ranges?*

**YES** : Go to step 9Y9.

**NO** : Go to step 9Y10.

#### 9Y9 : CHECK POOR CONTACT.

**CHECK** : *Is there poor contact in "2" range switch circuit?*

**YES** : Repair poor contact.

**NO** : Replace TCM. <Ref. to 3-2 [W22A0].>

#### 9Y10 : CHECK SELECTOR CABLE.

**CHECK** : *Is there faulty connection in the selector cable?*

**YES** : Repair connection of selector cable.

**NO** : Replace inhibitor switch. <Ref. to 3-2 [W2C0].>

**Z: CHECK "1" RANGE SWITCH.**

**DIAGNOSIS:**

Input signal circuit of "1" range is open or shorted.

**TROUBLE SYMPTOM:**

- Shift characteristics are erroneous.
- Engine brake is not effected when selector lever is in "1" range.

**WIRING DIAGRAM:**

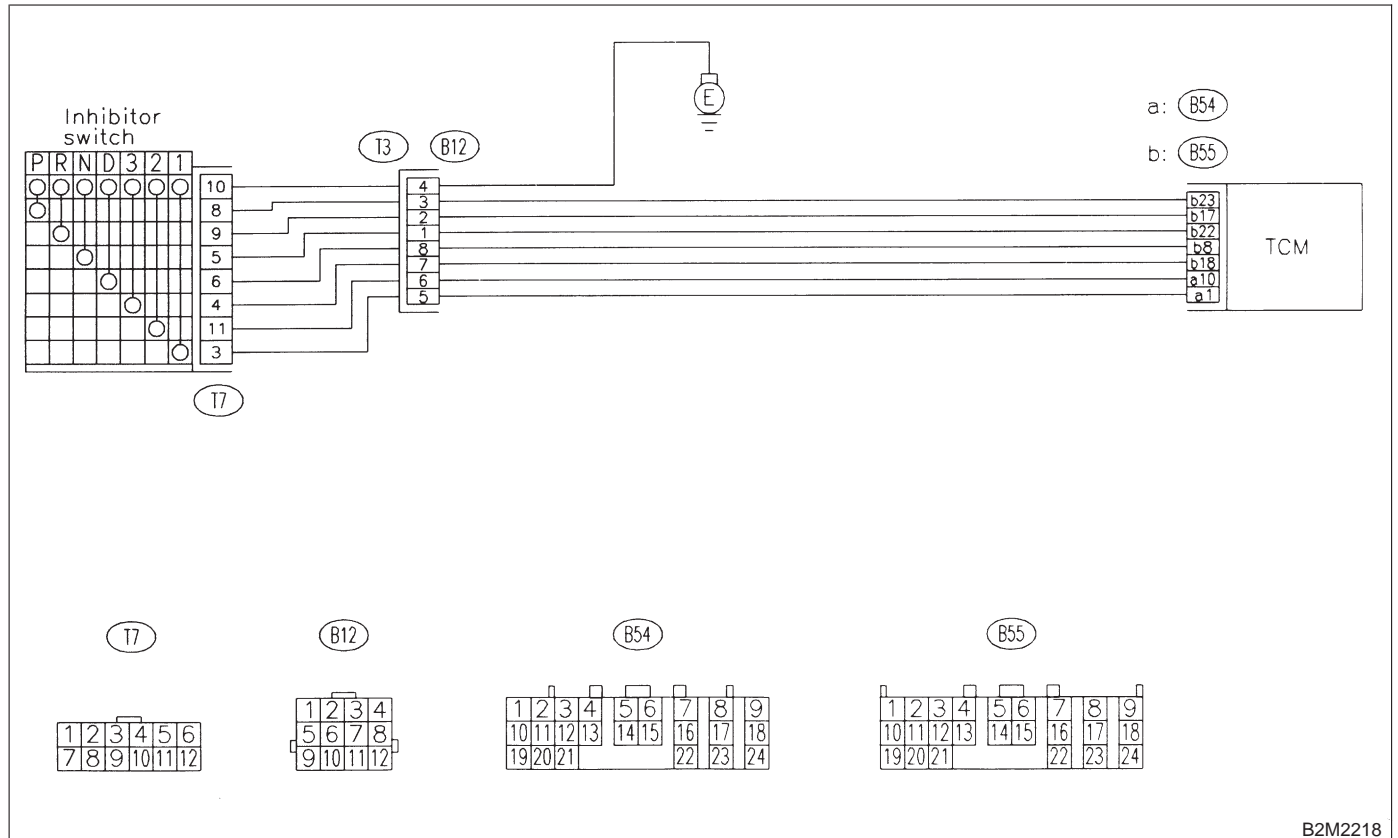

B2M2218

### 3-2 [T9Z1] AUTOMATIC TRANSMISSION AND DIFFERENTIAL

#### 9. Diagnostic Chart with Select Monitor

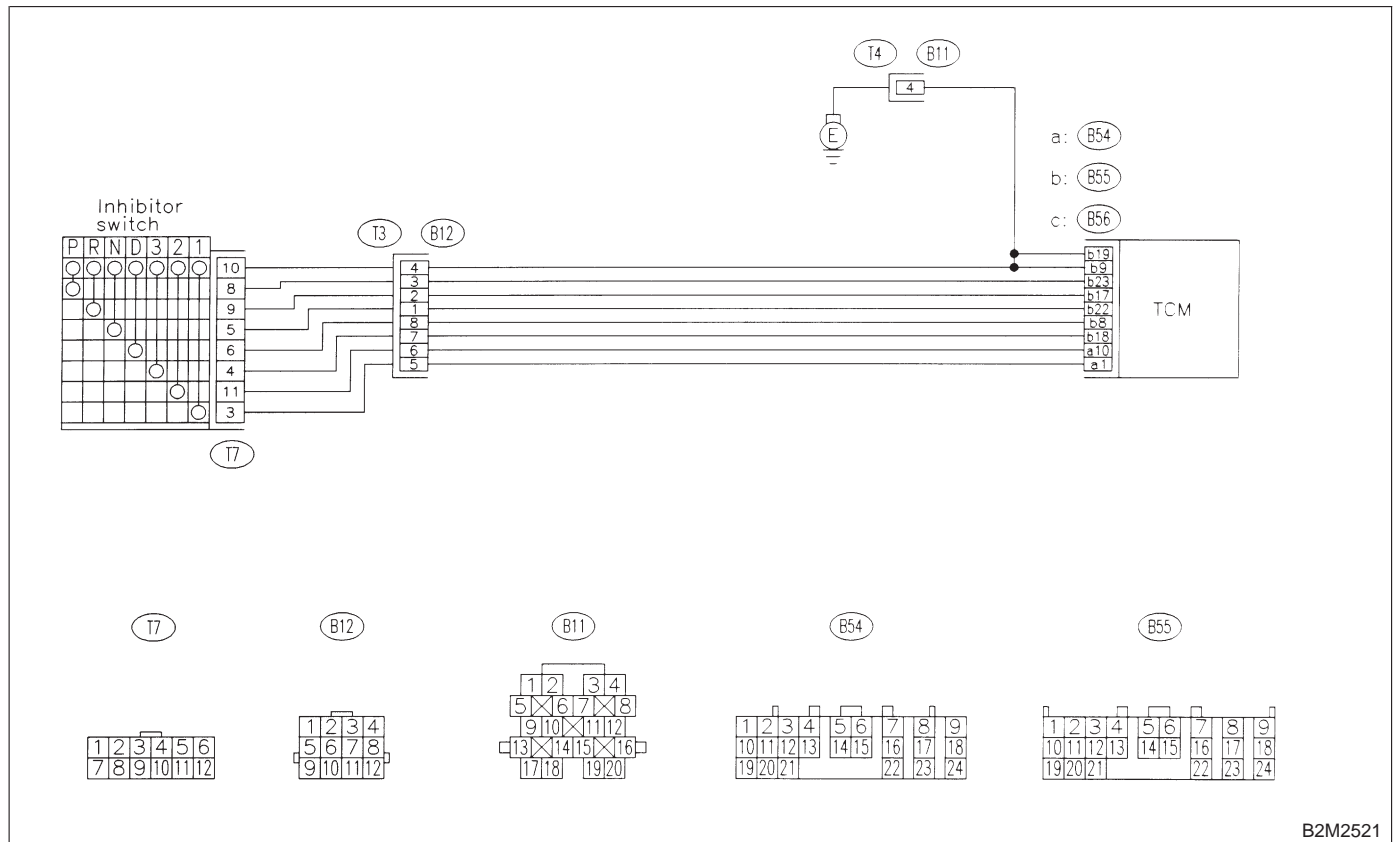

B2M2521

#### 9Z1 : CHECK "1" RANGE SWITCH.

- CHECK** : When the "1" range is selected, does LED light up?
- YES** : Go to step SHIFT SOLENOID 1. <Ref. to 3-2 [T9AA0].>
- NO** : Go to step 9Z2.

#### 9Z2 : CHECK HARNESS CONNECTOR BETWEEN TCM AND INHIBITOR SWITCH.

- 1) Turn ignition switch to OFF.
- 2) Disconnect connectors from TCM and inhibitor switch.
- 3) Measure resistance of harness between TCM and inhibitor switch connector.

**Connector & terminal**  
**(B54) No. 1 — (T7) No. 3:**

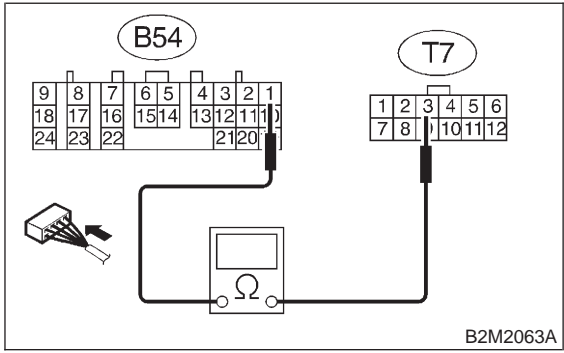

B2M2063A

- CHECK** : Is the resistance less than 1 Ω?
- YES** : Go to step 9Z3.
- NO** : Repair open circuit in harness between TCM and inhibitor switch connector, and poor contact in coupling connector.

**9Z3 : CHECK HARNESS CONNECTOR BETWEEN TCM AND INHIBITOR SWITCH.**

Measure resistance of harness between inhibitor switch connector and chassis ground.

**Connector & terminal**  
**(T7) No. 10 — (B55) No. 9:**

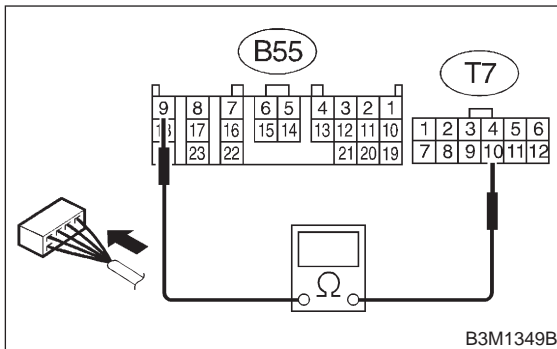

- CHECK** : *Is the resistance less than 1 Ω?*
- YES** : Go to step **9Z4**.
- NO** : Repair open circuit in harness between TCM and inhibitor switch connector, and poor contact in coupling connector.

**9Z4 : CHECK HARNESS CONNECTOR BETWEEN TCM AND INHIBITOR SWITCH.**

Measure resistance of harness between TCM and chassis ground.

**Connector & terminal**  
**(B54) No. 1 — Chassis ground:**

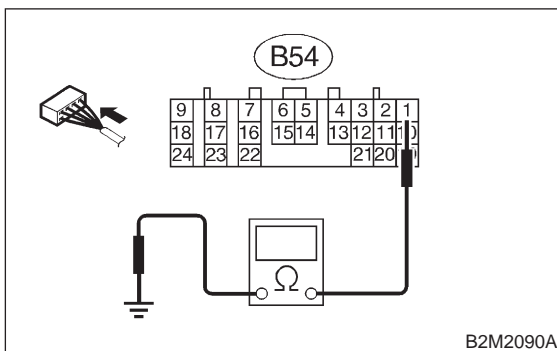

- CHECK** : *Is the resistance more than 1 MΩ?*
- YES** : Go to step **9Z5**.
- NO** : Repair ground short circuit in harness between TCM and inhibitor switch connector.

**9Z5 : CHECK INHIBITOR SWITCH.**

Measure resistance between inhibitor switch connector receptacle's terminals.

**Terminals**  
**No. 3 — No. 10:**

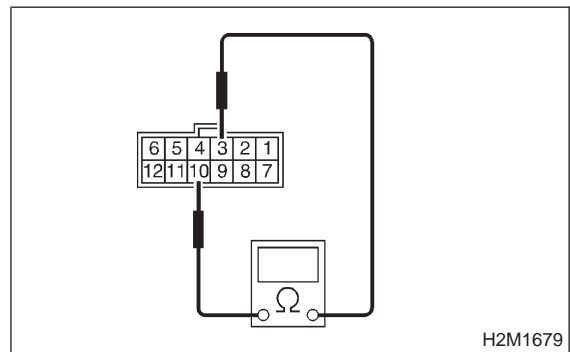

- CHECK** : *Is the resistance less than 1 Ω in "1" range?*
- YES** : Go to step **9Z6**.
- NO** : Go to step **9Z10**.

**9Z6 : CHECK INHIBITOR SWITCH.**

Measure resistance between inhibitor switch connector receptacle's terminals.

**Terminals**  
**No. 3 — No. 10:**

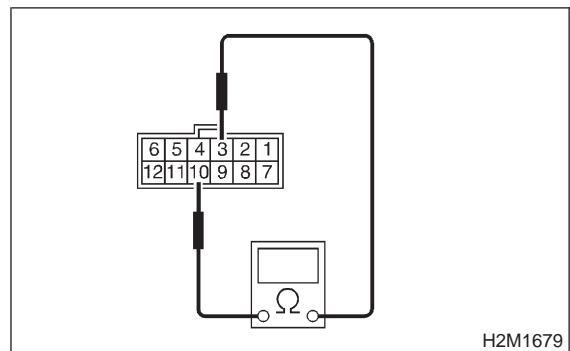

- CHECK** : *Is the resistance more than 1 MΩ in other ranges?*
- YES** : Go to step **9Z7**.
- NO** : Go to step **9Z10**.

## 3-2 [T9Z7] AUTOMATIC TRANSMISSION AND DIFFERENTIAL

### 9. Diagnostic Chart with Select Monitor

#### 9Z7 : CHECK INPUT SIGNAL FOR TCM.

- 1) Turn ignition switch to OFF.
- 2) Connect connector to TCM and inhibitor switch.
- 3) Turn ignition switch to ON.
- 4) Measure voltage between TCM and chassis ground.

#### Connector & terminal

(B54) No. 1 (+) — Chassis ground (-):

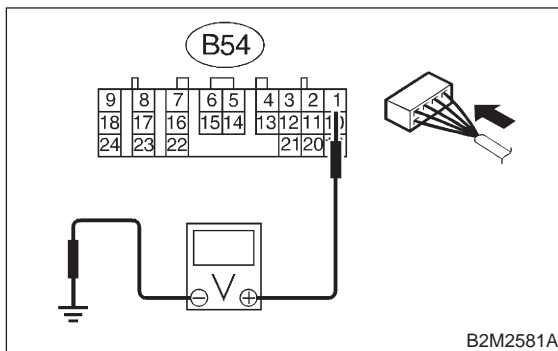

**CHECK** : Is the voltage less than 1 V in "1" range?

**YES** : Go to step 9Z8.

**NO** : Go to step 9Z9.

#### 9Z8 : CHECK INPUT SIGNAL FOR TCM.

Measure voltage between TCM and chassis ground.

#### Connector & terminal

(B54) No. 1 (+) — Chassis ground (-):

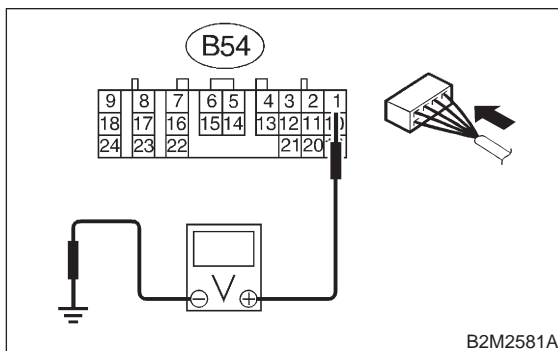

**CHECK** : Is the voltage more than 9.5 V in other ranges?

**YES** : Go to step 9Z9.

**NO** : Go to step 9Z10.

#### 9Z9 : CHECK POOR CONTACT.

**CHECK** : Is there poor contact in "1" range switch circuit?

**YES** : Repair poor contact.

**NO** : Replace TCM. <Ref. to 3-2 [W22A0].>

#### 9Z10 : CHECK SELECTOR CABLE.

**CHECK** : Is there faulty connection in the selector cable?

**YES** : Repair connection of selector cable.

**NO** : Replace inhibitor switch. <Ref. to 3-2 [W2C0].>

**AA: CHECK SHIFT SOLENOID 1.**

**9AA1 : CHECK SHIFT SOLENOID 1.**

- CHECK** : *Does the LED of shift solenoid 1 light up?*
- YES** : Go to step SHIFT SOLENOID 2. <Ref. to 3-2 [T9AB0].>
- NO** : Check shift solenoid 1 circuit. <Ref. to 3-2 [T8K0].>

**AB: CHECK SHIFT SOLENOID 2.**

**9AB1 : CHECK SHIFT SOLENOID 2.**

- CHECK** : *Does the LED of shift solenoid 2 light up?*
- YES** : Go to step TORQUE CONTROL 1 SIGNAL. <Ref. to 3-2 [T9AC0].>
- NO** : Check shift solenoid 2 circuit. <Ref. to 3-2 [T8L0].>

**AC: CHECK TORQUE CONTROL 1 SIGNAL.**

**9AC1 : CHECK TORQUE CONTROL 1 SIGNAL.**

Turn ignition switch to ON (engine ON).

- CHECK** : *Does the LED of torque control 1 signal light up?*
- YES** : Go to step TORQUE CONTROL SIGNAL 2 CIRCUIT. <Ref. to 3-2 [T9AD0].>
- NO** : Check torque control 1 signal circuit. <Ref. to 3-2 [T8I0].>

**AD: CHECK TORQUE CONTROL 2 SIGNAL.**

**9AD1 : CHECK TORQUE CONTROL 2 SIGNAL.**

Turn ignition switch to ON (engine ON).

- CHECK** : *Does the LED of torque control 2 signal light up?*
- YES** : Go to step 2-4 BRAKE TIMING SOLENOID. <Ref. to 3-2 [T9AE0].>
- NO** : Check torque control 2 signal circuit. <Ref. to 3-2 [T8I0].>

**AE: CHECK 2-4 BRAKE TIMING SOLENOID.**

**9AE1 : CHECK 2-4 BRAKE TIMING SOLENOID.**

Turn ignition switch to ON, and select 1 range.

- CHECK** : *Does the LED of 2-4 brake timing solenoid light up?*
- YES** : Go to step LOW CLUTCH TIMING SOLENOID. <Ref. to 3-2 [T9AF0].>
- NO** : Check 2-4 brake timing solenoid circuit. <Ref. to 3-2 [T8N0].>

**AF: CHECK LOW CLUTCH TIMING SOLENOID.**

**9AF1 : CHECK LOW CLUTCH TIMING SOLENOID.**

Turn ignition switch to ON, and select 2 range.

- CHECK** : *Does the LED of low clutch timing solenoid light up?*
- YES** : Go to step DIAGNOSIS LAMP. <Ref. to 3-2 [T9AG0].>
- NO** : Check low clutch timing solenoid circuit. <Ref. to 3-2 [T8M0].>

**AG: CHECK DIAGNOSIS LAMP.**

**9AG1 : CHECK DIAGNOSIS LAMP.**

Turn ignition switch to ON (engine OFF).

- CHECK** : *Does diagnosis lamp light up?*
- YES** : Go to step FWD LAMP. <Ref. to 3-2 [T9AH0].>
- NO** : Check diagnosis lamp circuit.

**AH: CHECK FWD LAMP.**

**9AH1 : CHECK FWD LAMP.**

- CHECK** : *Does the LED of FWD lamp light up?*
- YES** : Check FWD lamp circuit. <Ref. to 3-2 [T9Q0].>
- NO** : Go to step General Diagnostic Table. <Ref. to 3-2 [T1000].>

## **3-2 [T9AH1] AUTOMATIC TRANSMISSION AND DIFFERENTIAL**

9. Diagnostic Chart with Select Monitor

---

**MEMO:**