

10. Diagnostics Chart with Select Monitor

A: BASIC DIAGNOSTIC CHART

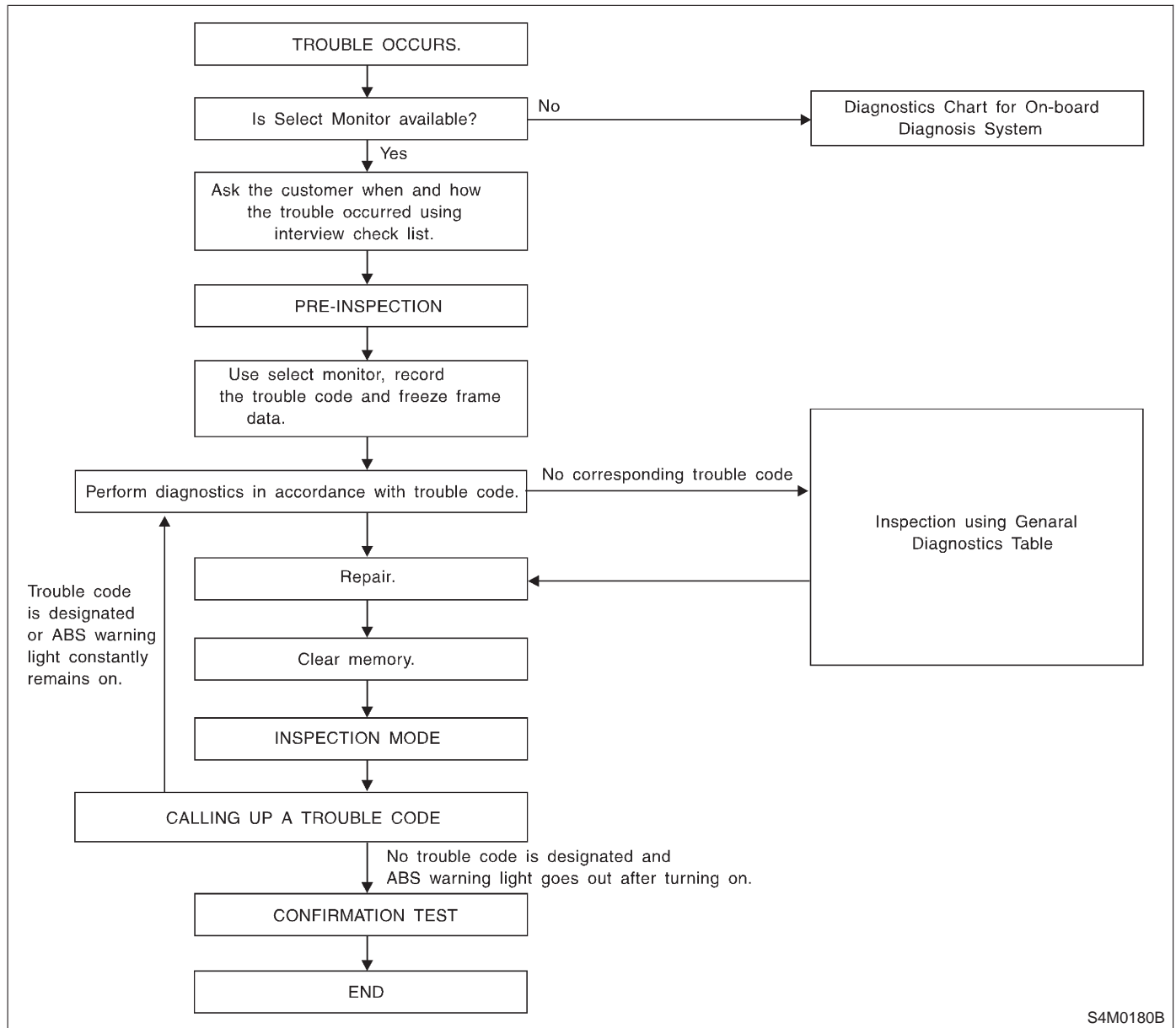

S4M0180B

CAUTION:

Remove foreign matter (dust, water, etc.) from the ABSCM&H/U connector during removal and installation.

NOTE:

- To check harness for broken wires or short circuits, shake it while holding it or the connector.
- Check list for interview, <Ref. to 4-4 [T6B0].>

B: LIST OF DIAGNOSTIC TROUBLE CODE

Code	Display screen	Contents of diagnosis	Index No.
—	Communication for initializing impossible	Select monitor communication failure	<Ref. to 4-4 [T10C0].>
—	No trouble code	Although no trouble code appears on the select monitor display, the ABS warning light remains on.	<Ref. to 4-4 [T10D0].>
21	Open or short circuit in front right ABS sensor circuit	Open or short circuit in front right ABS sensor circuit	<Ref. to 4-4 [T10E0].>
22	Front right ABS sensor abnormal signal	Front right ABS sensor abnormal signal	<Ref. to 4-4 [T10I0].>
23	Open or short circuit in front left ABS sensor circuit	Open or short circuit in front left ABS sensor circuit	<Ref. to 4-4 [T10F0].>
24	Front left ABS sensor abnormal signal	Front left ABS sensor abnormal signal	<Ref. to 4-4 [T10J0].>
25	Open or short circuit in rear right ABS sensor circuit	Open or short circuit in rear right ABS sensor circuit	<Ref. to 4-4 [T10G0].>
26	Rear right ABS sensor abnormal signal	Rear right ABS sensor abnormal signal	<Ref. to 4-4 [T10K0].>
27	Open or short circuit in rear left ABS sensor circuit	Open or short circuit in rear left ABS sensor circuit	<Ref. to 4-4 [T10H0].>
28	Rear left ABS sensor abnormal signal	Rear left ABS sensor abnormal signal	<Ref. to 4-4 [T10L0].>
29	Abnormal ABS sensor signal on any one of four sensor	Abnormal ABS sensor signal on any one of four	<Ref. to 4-4 [T10M0].>
31	Front right inlet valve malfunction	Front right inlet valve malfunction	<Ref. to 4-4 [T10N0].>
32	Front right outlet valve malfunction	Front right outlet valve malfunction	<Ref. to 4-4 [T10R0].>
33	Front left inlet valve malfunction	Front left inlet valve malfunction	<Ref. to 4-4 [T10O0].>
34	Front left outlet valve malfunction	Front left outlet valve malfunction	<Ref. to 4-4 [T10S0].>
35	Rear right inlet valve malfunction	Rear right inlet valve malfunction	<Ref. to 4-4 [T10P0].>
36	Rear right outlet valve malfunction	Rear right outlet valve malfunction	<Ref. to 4-4 [T10T0].>
37	Rear left inlet valve malfunction	Rear left inlet valve malfunction	<Ref. to 4-4 [T10Q0].>
38	Rear left outlet valve malfunction	Rear left outlet valve malfunction	<Ref. to 4-4 [T10U0].>
41	ABS control module malfunction	ABS control module and hydraulic control unit malfunction	<Ref. to 4-4 [T10V0].>
42	Power supply voltage too low	Power supply voltage too low	<Ref. to 4-4 [T10W0].>
42	Power supply voltage too high	Power supply voltage too high	<Ref. to 4-4 [T10X0].>
44	ABS-AT control (Non Controlled)	ABS-AT control (Non Controlled)	<Ref. to 4-4 [T10Y0].>
44	ABS-AT control (Controlled)	ABS-AT control (Controlled)	<Ref. to 4-4 [T10Z0].>
51	Valve relay malfunction	Valve relay malfunction	<Ref. to 4-4 [T10AA0].>
51	Valve relay ON failure	Valve relay ON failure	<Ref. to 4-4 [T10AB0].>
52	Open circuit in motor relay circuit	Open circuit in motor relay circuit	<Ref. to 4-4 [T10AC0].>
52	Motor relay ON failure	Motor relay ON failure	<Ref. to 4-4 [T10AD0].>
52	Motor malfunction	Motor malfunction	<Ref. to 4-4 [T10AE0].>
54	Stop light switch signal circuit malfunction	Stop light switch signal circuit malfunction	<Ref. to 4-4 [T10AF0].>
56	Open or short circuit in G sensor circuit	Open or short circuit in G sensor circuit	<Ref. to 4-4 [T10AG0].>
56	Battery short in G sensor circuit	Battery short in G sensor circuit	<Ref. to 4-4 [T10AH0].>
56	Abnormal G sensor high μ output	Abnormal G sensor high μ output	<Ref. to 4-4 [T10AI0].>
56	Detection of G sensor stick	Detection of G sensor stick	<Ref. to 4-4 [T10AJ0].>

NOTE:

High μ means high friction coefficient against road surface.

C: COMMUNICATION FOR INITIALIZING IMPOSSIBLE

— SELECT MONITOR COMMUNICATION FAILURE —

DIAGNOSIS:

- Faulty harness connector

TROUBLE SYMPTOM:

- ABS warning light remains on.

WIRING DIAGRAM:

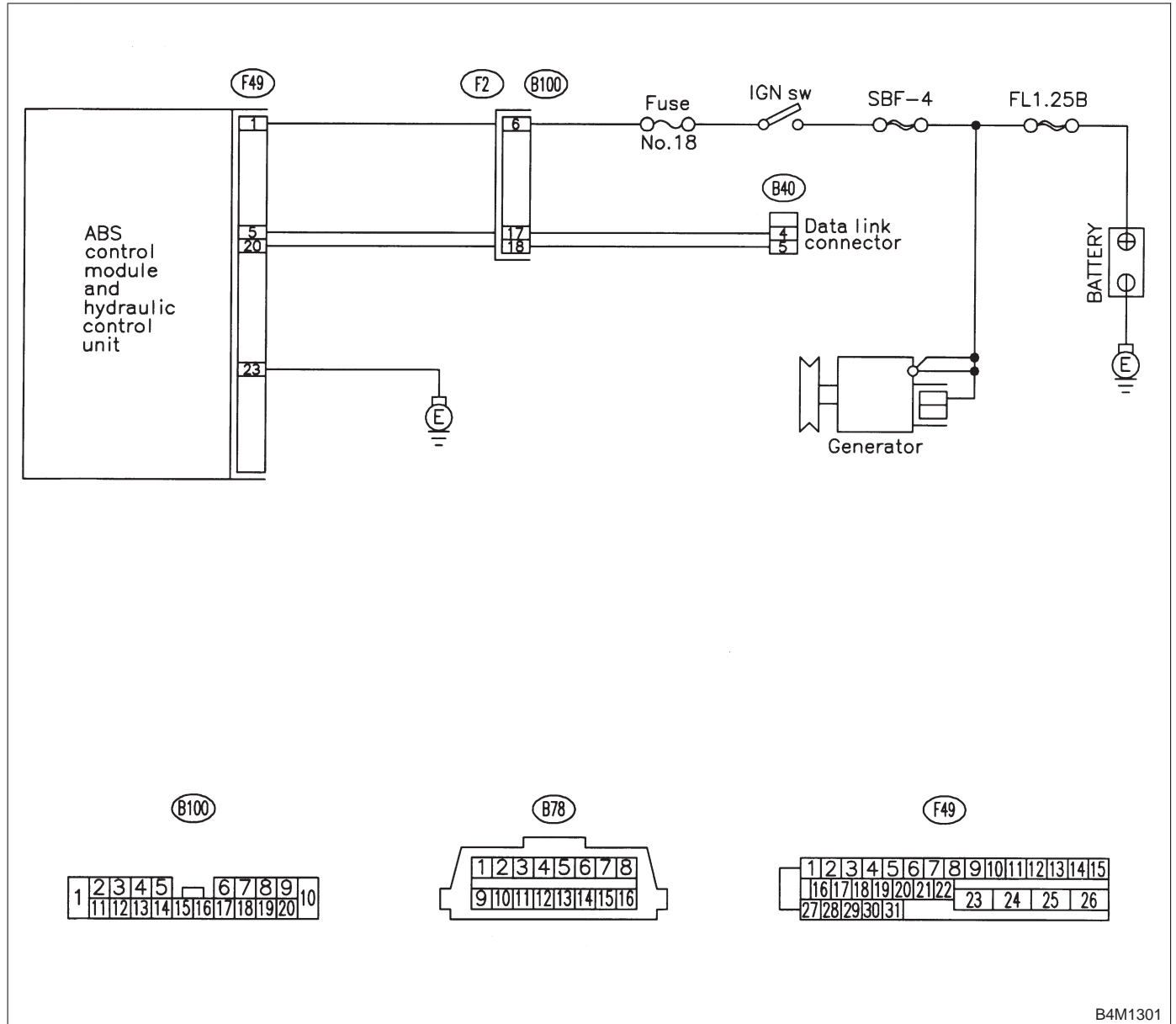

B4M1301

10C1 : CHECK IGNITION SWITCH.

- CHECK** : *Is ignition switch ON?*
- YES** : Go to step 10C2.
- NO** : Turn ignition switch ON, and select ABS/TCS mode using the select monitor.

10C2 : CHECK GENERATOR.

- 1) Start the engine.
- 2) Idle the engine.
- 3) Measure voltage between generator and chassis ground.

Terminal

Generator B terminal (+) — Chassis ground (-):

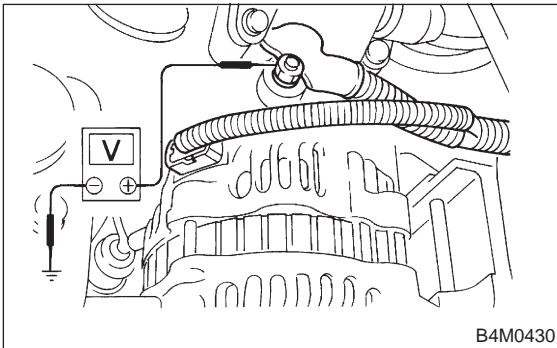

- CHECK** : *Is the voltage between 10 and 15 V?*
- YES** : Go to step 10C3.
- NO** : Repair generator.

10C3 : CHECK BATTERY TERMINAL.

Turn ignition switch to OFF.

- CHECK** : *Is there poor contact at battery terminal?*
- YES** : Repair battery terminal.
- NO** : Go to step 10C4.

10C4 : CHECK COMMUNICATION OF SELECT MONITOR.

Using the select monitor, check whether communication to other system (such as engine, AT, etc.) can be executed normally.

- CHECK** : *Are the name and year of the system displayed on the select monitor?*
- YES** : Go to step 10C5.
- NO** : Repair select monitor communication cable and connector.

10C5 : CHECK INSTALLATION OF ABSCM&H/U CONNECTOR.

Turn ignition switch to OFF.

- CHECK** : *Is ABSCM&H/U connector inserted into ABSCM&H/U until the clamp locks onto it?*
- YES** : Go to step 10C6.
- NO** : Insert ABSCM&H/U connector into ABSCM&H/U until the clamp locks onto it.

10C6 : CHECK POWER SUPPLY OF ABSCM&H/U.

- 1) Disconnect connector from ABSCM&H/U.
- 2) Start engine.
- 3) Idle the engine.
- 4) Measure voltage between ABSCM&H/U connector and chassis ground.

Connector & terminal

(F49) No. 1 (+) — Chassis ground (-):

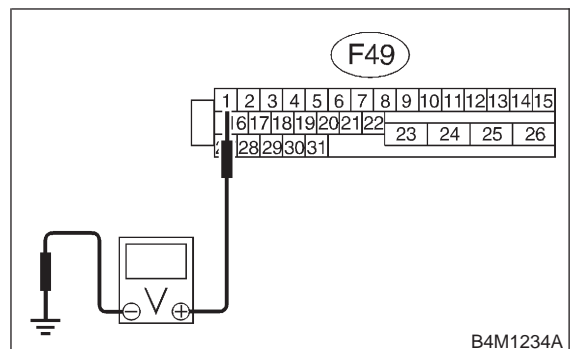

- CHECK** : *Is the voltage between 10 and 15 V?*
- YES** : Go to step 10C7.
- NO** : Repair ABSCM&H/U power supply circuit.

4-4 [T10C7]

10. Diagnostics Chart with Select Monitor

BRAKES

10C7 : CHECK GROUND CIRCUIT OF ABSCM&H/U.

- 1) Turn ignition switch to OFF.
- 2) Measure resistance between ABSCM&H/U connector and chassis ground.

Connector & terminal

(F49) No. 23 — Chassis ground:

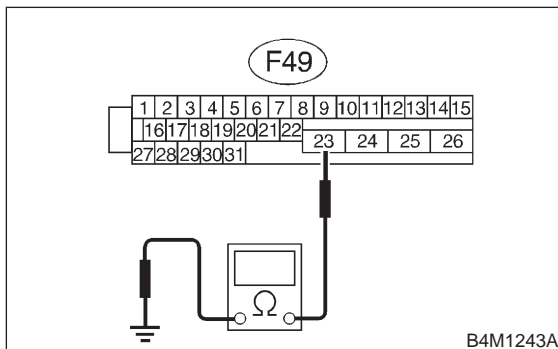

- CHECK** : Is the resistance less than 0.5 Ω?
- YES** : Repair harness/connector between ABSCM&H/U and select monitor.
- NO** : Go to step 10C8.

10C8 : CHECK HARNESS/CONNECTOR BETWEEN ABSCM&H/U AND DATA LINK CONNECTOR.

- 1) Turn ignition switch OFF.
- 2) Measure resistance between ABSCM&H/U connector and data link connector.

Connector & terminal

(F49) No. 20 — (B40) No. 5:

(F49) No. 5 — (B40) No. 4:

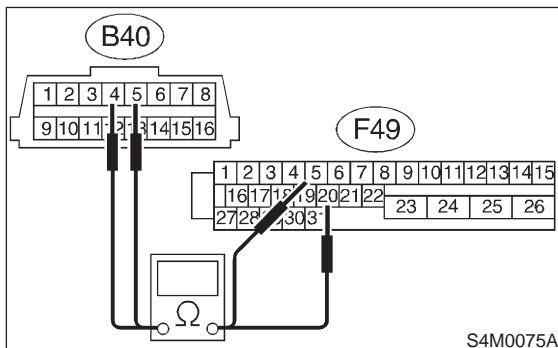

- CHECK** : Is the resistance less than 0.5 Ω?
- YES** : Repair harness and connector between ABSCM&H/U and data link connector.
- NO** : Go to step 10C9.

10C9 : CHECK POOR CONTACT IN CONNECTORS.

- CHECK** : Is there poor contact in connectors between ABSCM&H/U and data link connector? <Ref. to FOREWORD [T3C1].>
- YES** : Repair connector.
- NO** : Replace ABSCM&H/U.

BRAKES

[T10C9] 4-4

10. Diagnostics Chart with Select Monitor

MEMO:

D: NO TROUBLE CODE

— ALTHOUGH NO TROUBLE CODE APPEARS ON THE SELECT MONITOR DISPLAY, THE ABS WARNING LIGHT REMAINS ON. —

DIAGNOSIS:

- ABS warning light circuit is shorted.

TROUBLE SYMPTOM:

- ABS warning light remains on.
- NO TROUBLE CODE displayed on the select monitor.

NOTE:

When the ABS warning light is OFF and "NO TROUBLE CODE" is displayed on the select monitor, the system is in normal condition.

WIRING DIAGRAM:

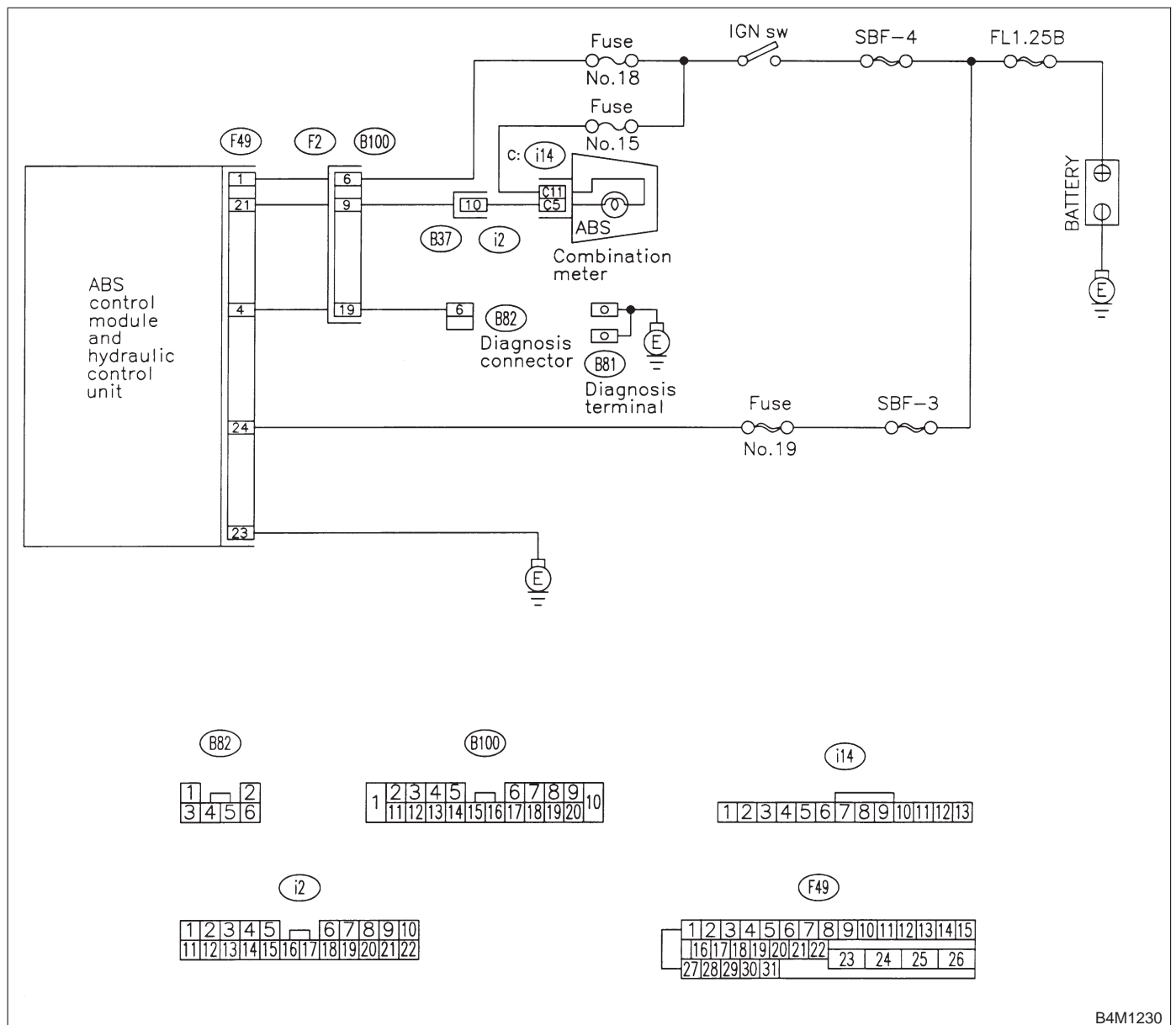

B4M1230

10D1 : CHECK WIRING HARNESS.

- 1) Turn ignition switch to OFF.
- 2) Disconnect connector (F2) from connector (B100).
- 3) Turn ignition switch to ON.

CHECK : *Does the ABS warning light remain off?*

YES : Go to step **10D2**.

NO : Repair front wiring harness.

10D2 : CHECK PROJECTION AT ABSCM&H/U.

- 1) Turn ignition switch to OFF.
- 2) Disconnect connector from ABSCM&H/U.
- 3) Check for broken projection at the ABSCM&H/U terminal.

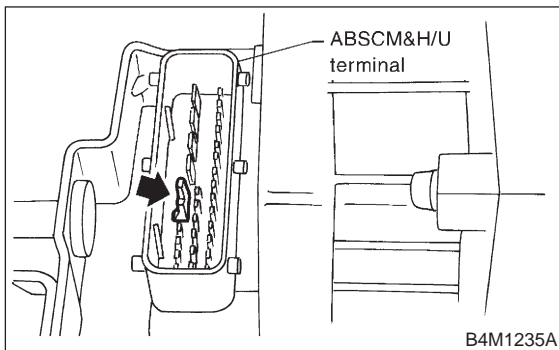

CHECK : *Are the projection broken?*

YES : Go to step **10D3**.

NO : Replace ABSCM&H/U.

10D3 : CHECK ABSCM&H/U.

Measure resistance between ABSCM&H/U terminals.

Terminals

No. 21 — No. 23:

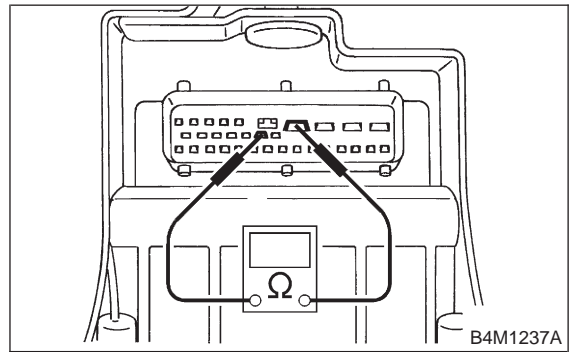

CHECK : *Is the resistance more than 1 MΩ?*

YES : Go to step **10D4**.

NO : Replace valve relay.

10D4 : CHECK WIRING HARNESS.

Measure resistance between connector (F2) and chassis ground.

Connector & terminal

(F2) No. 9 — Chassis ground:

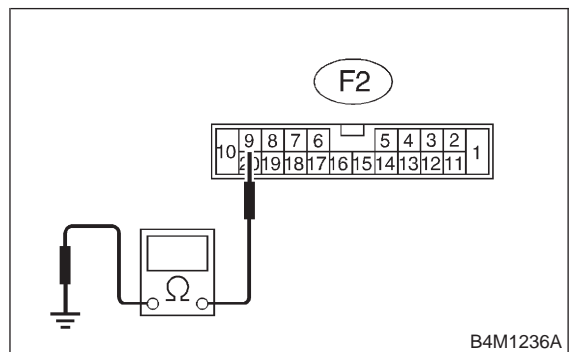

CHECK : *Is the resistance less than 0.5 Ω?*

YES : Go to step **10D5**.

NO : Repair harness.

10D5 : CHECK WIRING HARNESS.

- 1) Connect connector to ABSCM&H/U.
- 2) Measure resistance between connector (F2) and chassis ground.

Connector & terminal

(F2) No. 9 — Chassis ground:

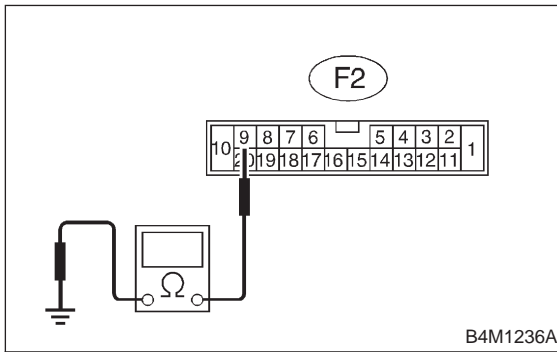

- CHECK** : *Is the resistance more than 1 MΩ?*
- YES** : Go to step 10D6.
- NO** : Repair harness.

10D6 : CHECK POOR CONTACT IN ABSCM&H/U CONNECTOR.

- CHECK** : *Is there poor contact in ABSCM&H/U connector? <Ref. to FOREWORD [T3C1].>*
- YES** : Repair connector.
- NO** : Replace ABSCM&H/U.

BRAKES

[T10D6] 4-4

10. Diagnostics Chart with Select Monitor

MEMO:

E: TROUBLE CODE 21 OPEN OR SHORT CIRCUIT IN FRONT RIGHT ABS SENSOR CIRCUIT

F: TROUBLE CODE 23 OPEN OR SHORT CIRCUIT IN FRONT LEFT ABS SENSOR CIRCUIT

G: TROUBLE CODE 25 OPEN OR SHORT CIRCUIT IN REAR RIGHT ABS SENSOR CIRCUIT

H: TROUBLE CODE 27 OPEN OR SHORT CIRCUIT IN REAR LEFT ABS SENSOR CIRCUIT

— ABNORMAL ABS SENSOR (OPEN OR SHORT CIRCUIT IN ABS SENSOR CIRCUIT) —

DIAGNOSIS:

- Faulty ABS sensor (Broken wire, input voltage too high)
- Faulty harness connector

TROUBLE SYMPTOM:

- ABS does not operate.

WIRING DIAGRAM:

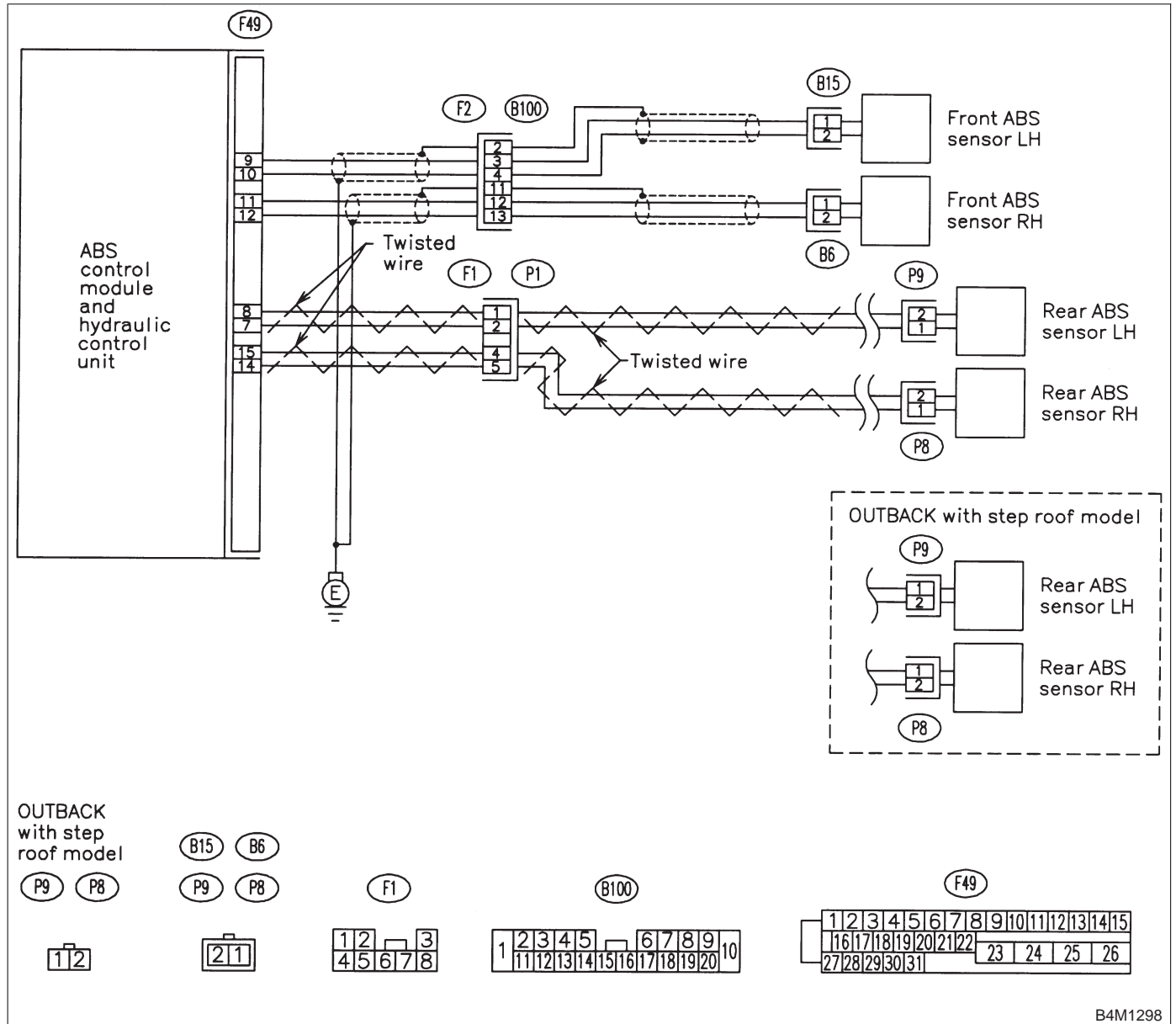

B4M1298

10H1 : CHECK OUTPUT OF ABS SENSOR USING SELECT MONITOR.

- 1) Select "Current data display & Save" on the select monitor.
- 2) Read the ABS sensor output corresponding to the faulty system in the select monitor data display mode.

CHECK : *Does the speed indicated on the display change in response to the speedometer reading during acceleration/deceleration when the steering wheel is in the straight-ahead position?*

YES : Go to step 10H2.

NO : Go to step 10H9.

10H2 : CHECK INSTALLATION OF ABS SENSOR.

Tightening torque:

32±10 N-m (3.3±1.0 kg-m, 24±7 ft-lb)

CHECK : *Are the ABS sensor installation bolts tightened securely?*

YES : Go to step 10H3.

NO : Tighten ABS sensor installation bolts securely.

10H3 : CHECK INSTALLATION OF TONE WHEEL.

Tightening torque:

13±3 N-m (1.3±0.3 kg-m, 9.4±2.2 ft-lb)

CHECK : *Are the tone wheel installation bolts tightened securely?*

YES : Go to step 10H4.

NO : Tighten tone wheel installation bolts securely.

10H4 : CHECK ABS SENSOR GAP.

Measure tone wheel-to-pole piece gap over entire perimeter of the wheel.

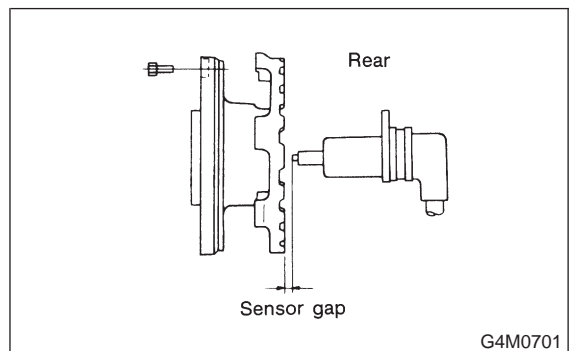
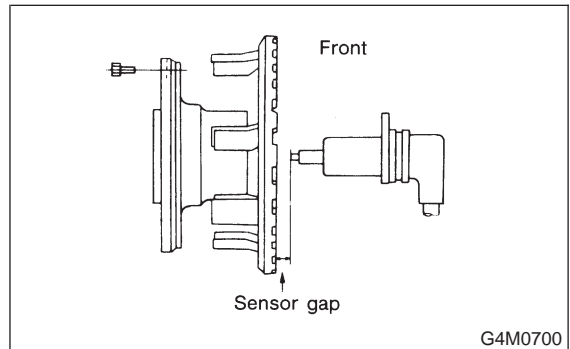

	Front wheel	Rear wheel
Specifications	0.9 — 1.4 mm (0.035 — 0.055 in)	0.7 — 1.2 mm (0.028 — 0.047 in)

CHECK : *Is the gap within the specifications?*

YES : Go to step 10H5.

NO : Adjust the gap.

NOTE:

Adjust the gap using spacers (Part No. 26755AA000). If spacers cannot correct the gap, replace worn sensor or worn tone wheel.

10H5 : CHECK HUB RUNOUT.

Measure hub runout.

CHECK : *Is the runout less than 0.05 mm (0.0020 in)?*

YES : Go to step 10H6.

NO : Repair hub.

10H6 : CHECK POOR CONTACT IN CONNECTORS.

Turn ignition switch to OFF.

CHECK : *Is there poor contact in connectors between ABSCM&H/U and ABS sensor? <Ref. to FOREWORD [T3C1].>*

YES : Repair connector.

NO : Go to step 10H7.

10H7 : CHECK ABSCM&H/U.

- 1) Connect all connectors.
- 2) Erase the memory.
- 3) Perform inspection mode.
- 4) Read out the trouble code.

CHECK : *Is the same trouble code as in the current diagnosis still being output?*

YES : Replace ABSCM&H/U.

NO : Go to step 10H8.

10H8 : CHECK ANY OTHER TROUBLE CODES APPEARANCE.

CHECK : *Are other trouble codes being output?*

YES : Proceed with the diagnosis corresponding to the trouble code.

NO : A temporary poor contact.

NOTE:

Check harness and connectors between ABSCM&H/U and ABS sensor.

10H9 : CHECK ABS SENSOR.

- 1) Turn ignition switch to OFF.
- 2) Disconnect connector from ABS sensor.
- 3) Measure resistance of ABS sensor connector terminals.

Terminal

Front RH No. 1 — No. 2:

Front LH No. 1 — No. 2:

Rear RH No. 1 — No. 2:

Rear LH No. 1 — No. 2:

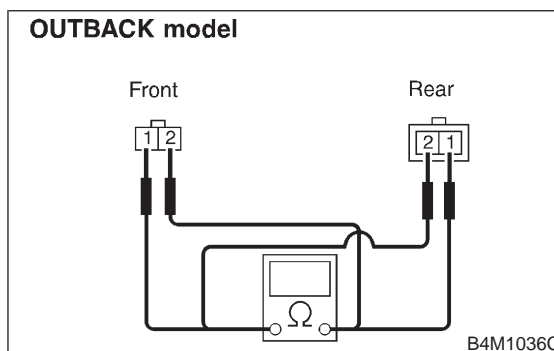
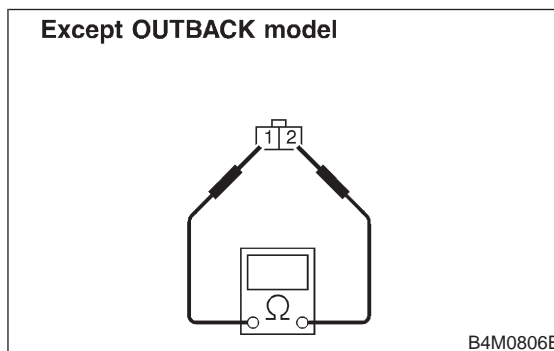

CHECK : *Is the resistance between 0.8 and 1.2 kΩ?*

YES : Go to step 10H10.

NO : Replace ABS sensor.

10H10 : CHECK BATTERY SHORT OF ABS SENSOR.

- 1) Disconnect connector from ABSCM&H/U.
- 2) Measure voltage between ABS sensor and chassis ground.

Terminal

Front RH No. 1 (+) — Chassis ground (-):

Front LH No. 1 (+) — Chassis ground (-):

Rear RH No. 1 (+) — Chassis ground (-):

Rear LH No. 1 (+) — Chassis ground (-):

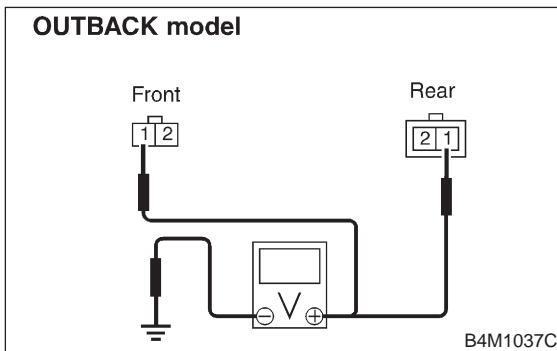
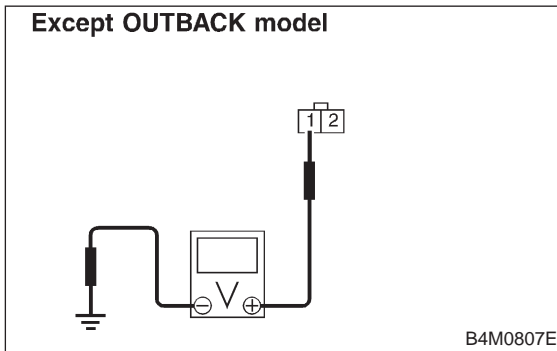

CHECK : Is the voltage less than 1 V?

YES : Go to step 10H11.

NO : Replace ABS sensor.

10H11 : CHECK BATTERY SHORT OF ABS SENSOR.

- 1) Turn ignition switch to ON.
- 2) Measure voltage between ABS sensor and chassis ground.

Terminal

Front RH No. 1 (+) — Chassis ground (-):

Front LH No. 1 (+) — Chassis ground (-):

Rear RH No. 1 (+) — Chassis ground (-):

Rear LH No. 1 (+) — Chassis ground (-):

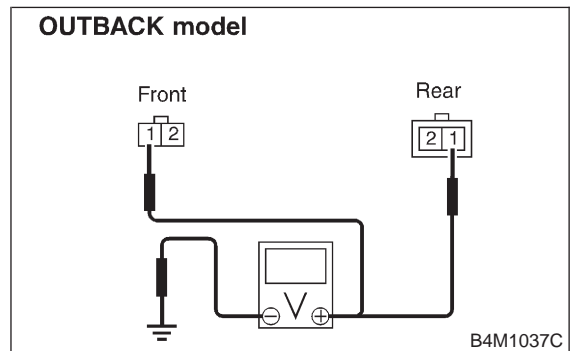
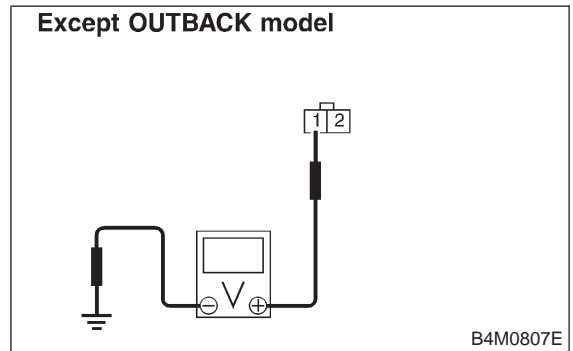

CHECK : Is the voltage less than 1 V?

YES : Go to step 10H12.

NO : Replace ABS sensor.

10H12 : CHECK HARNESS/CONNECTOR BETWEEN ABSCM&H/U AND ABS SENSOR.

- 1) Turn ignition switch to OFF.
- 2) Connect connector to ABS sensor.
- 3) Measure resistance between ABSCM&H/U connector terminals.

Connector & terminal

- Trouble code 21 / (F49) No. 11 — No. 12:**
- Trouble code 23 / (F49) No. 9 — No. 10:**
- Trouble code 25 / (F49) No. 14 — No. 15:**
- Trouble code 27 / (F49) No. 7 — No. 8:**

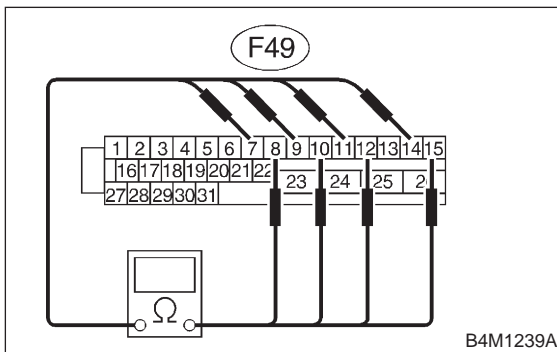

- CHECK** : **Is the resistance between 0.8 and 1.2 kΩ?**
- YES** : Go to step **10H13**.
- NO** : Repair harness/connector between ABSCM&H/U and ABS sensor.

10H13 : CHECK BATTERY SHORT OF HARNESS.

Measure voltage between ABSCM&H/U connector and chassis ground.

Connector & terminal

- Trouble code 21 / (F49) No. 11 (+) — Chassis ground (-):**
- Trouble code 23 / (F49) No. 9 (+) — Chassis ground (-):**
- Trouble code 25 / (F49) No. 14 (+) — Chassis ground (-):**
- Trouble code 27 / (F49) No. 7 (+) — Chassis ground (-):**

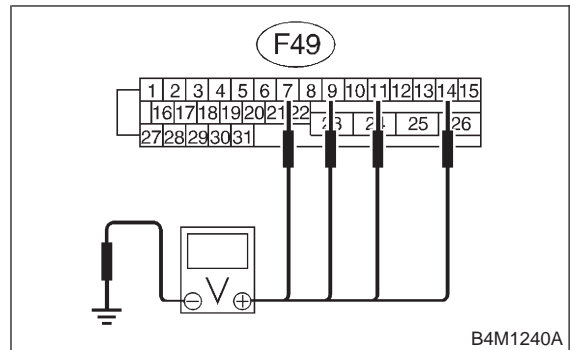

- CHECK** : **Is the voltage less than 1 V?**
- YES** : Go to step **10H14**.
- NO** : Repair harness between ABSCM&H/U and ABS sensor.

10H14 : CHECK BATTERY SHORT OF HARNESS.

- 1) Turn ignition switch to ON.
- 2) Measure voltage between ABSCM&H/U connector and chassis ground.

Connector & terminal

- Trouble code 21 / (F49) No. 11 (+) — Chassis ground (-):**
Trouble code 23 / (F49) No. 9 (+) — Chassis ground (-):
Trouble code 25 / (F49) No. 14 (+) — Chassis ground (-):
Trouble code 27 / (F49) No. 7 (+) — Chassis ground (-):

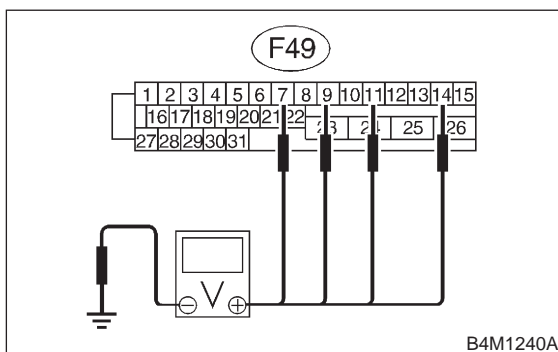

- CHECK** : Is the voltage less than 1 V?
- YES** : Go to step 10H15.
- NO** : Repair harness between ABSCM&H/U and ABS sensor.

10H15 : CHECK INSTALLATION OF ABS SENSOR.

Tightening torque:

32±10 N·m (3.3±1.0 kg·m, 24±7 ft·lb)

- CHECK** : Are the ABS sensor installation bolts tightened securely?
- YES** : Go to step 10H16.
- NO** : Tighten ABS sensor installation bolts securely.

10H16 : CHECK INSTALLATION OF TONE WHEEL.

Tightening torque:

13±3 N·m (1.3±0.3 kg·m, 9.4±2.2 ft·lb)

- CHECK** : Are the tone wheel installation bolts tightened securely?
- YES** : Go to step 10H17.
- NO** : Tighten tone wheel installation bolts securely.

10H17 : CHECK ABS SENSOR GAP.

Measure tone wheel-to-pole piece gap over entire perimeter of the wheel.

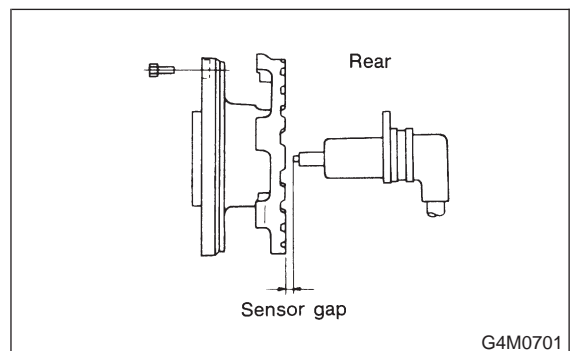
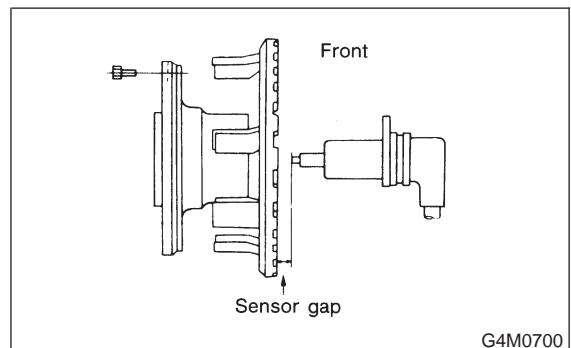

	Front wheel	Rear wheel
Specifications	0.9 — 1.4 mm (0.035 — 0.055 in)	0.7 — 1.2 mm (0.028 — 0.047 in)

- CHECK** : Is the gap within the specifications?
- YES** : Go to step 10H18.
- NO** : Adjust the gap.

NOTE:

Adjust the gap using spacers (Part No. 26755AA000). If spacers cannot correct the gap, replace worn sensor or worn tone wheel.

10H18 : CHECK HUB RUNOUT.

Measure hub runout.

- CHECK** : *Is the runout less than 0.05 mm (0.0020 in)?*
- YES** : Go to step 10H19.
- NO** : Repair hub.

10H19 : CHECK GROUND SHORT OF ABS SENSOR.

- 1) Turn ignition switch to ON.
- 2) Measure resistance between ABS sensor and chassis ground.

Terminal

- Front RH No. 1 — Chassis ground:**
- Front LH No. 1 — Chassis ground:**
- Rear RH No. 1 — Chassis ground:**
- Rear LH No. 1 — Chassis ground:**

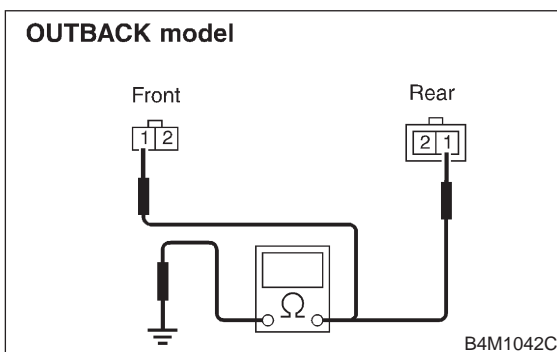
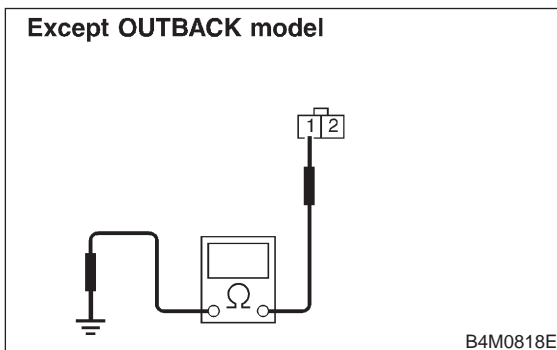

- CHECK** : *Is the resistance more than 1 MΩ?*
- YES** : Go to step 10H20.
- NO** : Replace ABS sensor and ABSCM&H/U.

10H20 : CHECK GROUND SHORT OF HARNESS.

- 1) Turn ignition switch to OFF.
- 2) Connect connector to ABS sensor.
- 3) Measure resistance between ABSCM&H/U connector terminal and chassis ground.

Connector & terminal

- Trouble code 21 / (F49) No. 11 — Chassis ground:**
- Trouble code 23 / (F49) No. 9 — Chassis ground:**
- Trouble code 25 / (F49) No. 14 — Chassis ground:**
- Trouble code 27 / (F49) No. 7 — Chassis ground:**

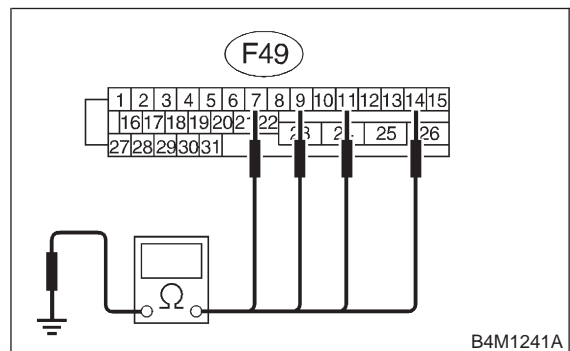

- CHECK** : *Is the resistance more than 1 MΩ?*
- YES** : Go to step 10H21.
- NO** : Repair harness between ABSCM&H/U and ABS sensor. And replace ABSCM&H/U.

10H21 : CHECK POOR CONTACT IN CONNECTORS.

- CHECK** : *Is there poor contact in connectors between ABSCM&H/U and ABS sensor? <Ref. to FOREWORD [T3C1].>*
- YES** : Repair connector.
- NO** : Go to step 10H22.

10H22 : CHECK ABSCM&H/U.

- 1) Connect all connectors.
- 2) Erase the memory.
- 3) Perform inspection mode.
- 4) Read out the trouble code.

CHECK : *Is the same trouble code as in the current diagnosis still being output?*

YES : Replace ABSCM&H/U.

NO : Go to step **10H23**.

10H23 : CHECK ANY OTHER TROUBLE CODES APPEARANCE.

CHECK : *Are other trouble codes being output?*

YES : Proceed with the diagnosis corresponding to the trouble code.

NO : A temporary poor contact.

NOTE:

Check harness and connectors between ABSCM&H/U and ABS sensor.

BRAKES

[T10H23] 4-4

10. Diagnostics Chart with Select Monitor

MEMO:

I: TROUBLE CODE 22 FRONT RIGHT ABS SENSOR ABNORMAL SIGNAL

J: TROUBLE CODE 24 FRONT LEFT ABS SENSOR ABNORMAL SIGNAL

K: TROUBLE CODE 26 REAR RIGHT ABS SENSOR ABNORMAL SIGNAL

L: TROUBLE CODE 28 REAR LEFT ABS SENSOR ABNORMAL SIGNAL

— ABNORMAL ABS SENSOR (ABS SENSOR ABNORMAL SIGNAL) —

DIAGNOSIS:

- Faulty ABS sensor signal (noise, irregular signal, etc.)
- Faulty harness/connector

TROUBLE SYMPTOM:

- ABS does not operate.

WIRING DIAGRAM:

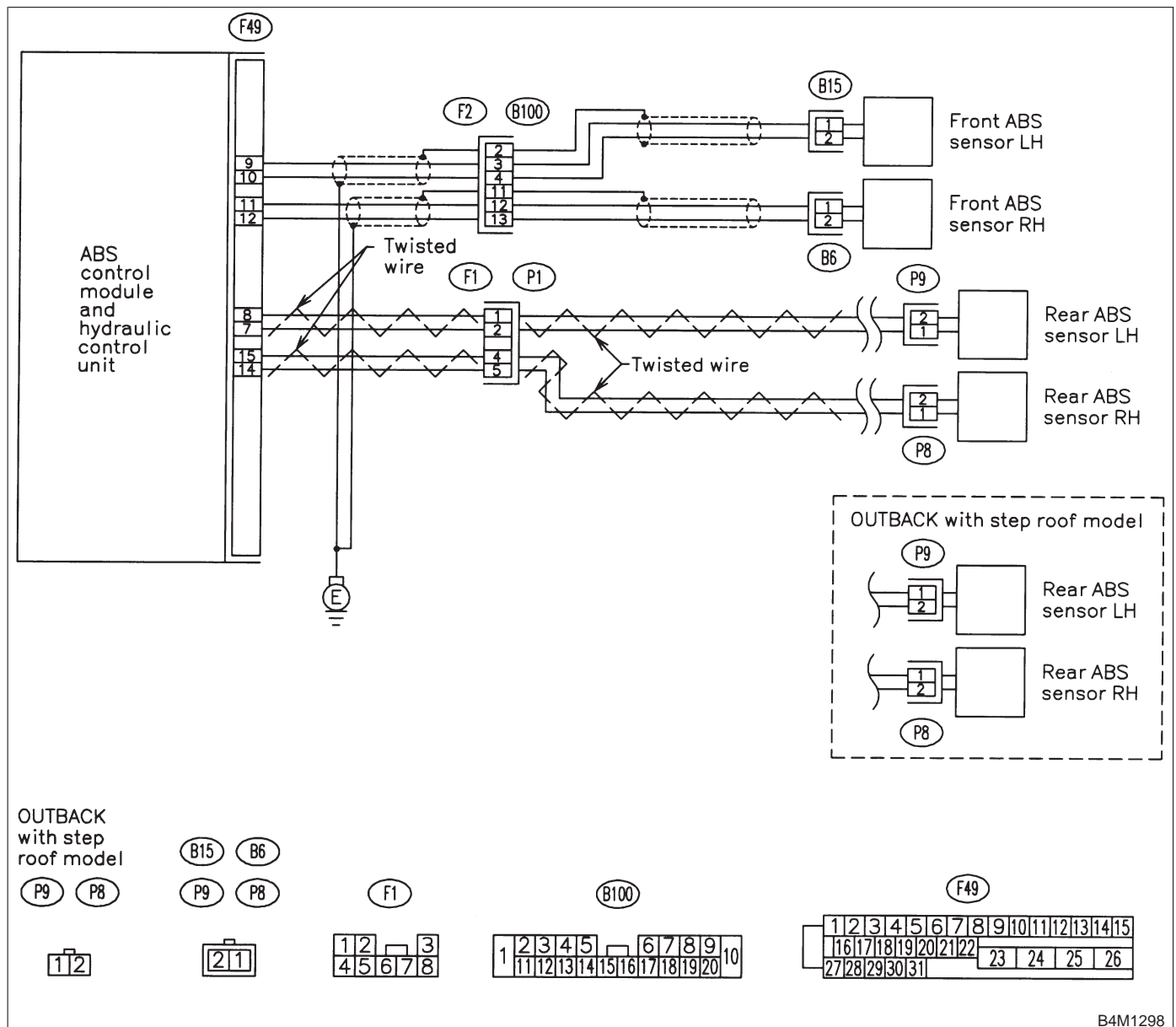

10L1 : CHECK OUTPUT OF ABS SENSOR USING SELECT MONITOR.

- 1) Select "Current data display & Save" on the select monitor.
- 2) Read the ABS sensor output corresponding to the faulty system in the select monitor data display mode.

CHECK : *Does the speed indicated on the display change in response to the speedometer reading during acceleration/deceleration when the steering wheel is in the straight-ahead position?*

YES : Go to step 10L2.

NO : Go to step 10L8.

10L2 : CHECK POOR CONTACT IN CONNECTORS.

Turn ignition switch to OFF.

CHECK : *Is there poor contact in connectors between ABSCM&H/U and ABS sensor?*

YES : Repair connector.

NO : Go to step 10L3.

10L3 : CHECK SOURCES OF SIGNAL NOISE.

CHECK : *Is the car telephone or the wireless transmitter properly installed?*

YES : Go to step 10L4.

NO : Properly install the car telephone or the wireless transmitter.

10L4 : CHECK SOURCES OF SIGNAL NOISE.

CHECK : *Are noise sources (such as an antenna) installed near the sensor harness?*

YES : Install the noise sources apart from the sensor harness.

NO : Go to step 10L5.

10L5 : CHECK SHIELD CIRCUIT.

- 1) Turn ignition switch to OFF.
- 2) Connect all connectors.
- 3) Measure resistance between shield connector and chassis ground.

Connector & terminal

Trouble code 22 / (B100) No. 11 — Chassis ground:

Trouble code 24 / (B100) No. 2 — Chassis ground:

Trouble code 26 / Go to step 10L6.

Trouble code 28 / Go to step 10L6.

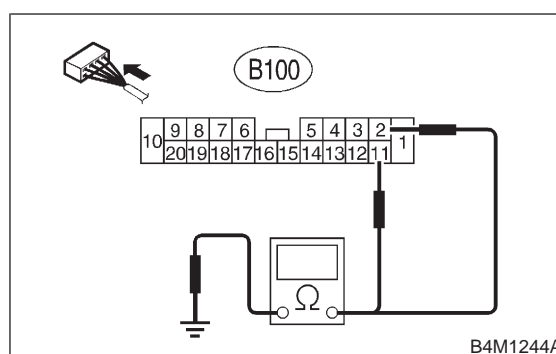

CHECK : *Is the resistance less than 0.5 Ω?*

YES : Go to step 10L6.

NO : Repair shield harness.

10L6 : CHECK ABSCM&H/U.

- 1) Connect all connectors.
- 2) Erase the memory.
- 3) Perform inspection mode.
- 4) Read out the trouble code.

CHECK : *Is the same trouble code as in the current diagnosis still being output?*

YES : Replace ABSCM&H/U.

NO : Go to step 10L7.

10L7 : CHECK ANY OTHER TROUBLE CODES APPEARANCE.

CHECK : *Are other trouble codes being output?*

YES : Proceed with the diagnosis corresponding to the trouble code.

NO : A temporary noise interference.

10L8 : CHECK INSTALLATION OF ABS SENSOR.

Tightening torque:

32±10 N·m (3.3±1.0 kg·m, 24±7 ft·lb)

- CHECK** : Are the ABS sensor installation bolts tightened securely?
- YES** : Go to step 10L9.
- NO** : Tighten ABS sensor installation bolts securely.

10L9 : CHECK INSTALLATION OF TONE WHEEL.

Tightening torque:

13±3 N·m (1.3±0.3 kg·m, 9.4±2.2 ft·lb)

- CHECK** : Are the tone wheel installation bolts tightened securely?
- YES** : Go to step 10L10.
- NO** : Tighten tone wheel installation bolts securely.

10L10 : CHECK ABS SENSOR GAP.

Measure tone wheel to pole piece gap over entire perimeter of the wheel.

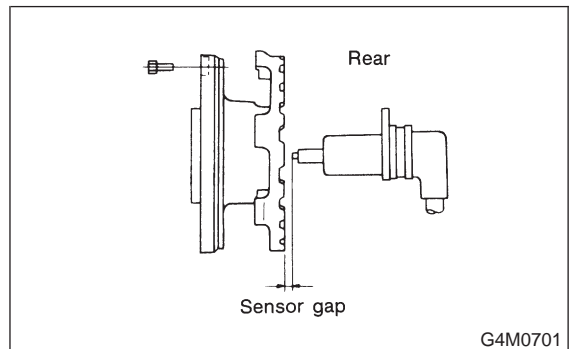
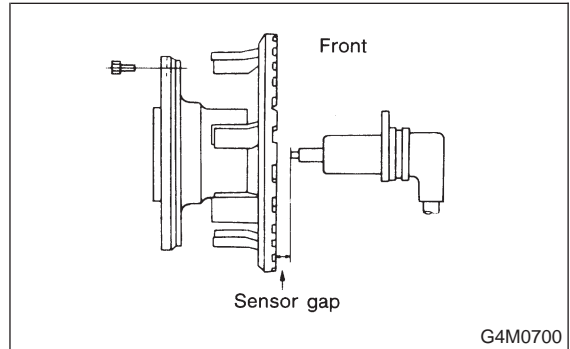

	Front wheel	Rear wheel
Specifications	0.9 — 1.4 mm (0.035 — 0.055 in)	0.7 — 1.2 mm (0.028 — 0.047 in)

- CHECK** : Is the gap within the specifications?
- YES** : Go to step 10L11.
- NO** : Adjust the gap.

NOTE:

Adjust the gap using spacer (Part No. 26755AA000). If spacers cannot correct the gap, replace worn sensor or worn tone wheel.

10L11 : CHECK OSCILLOSCOPE.

- CHECK** : Is an oscilloscope available?
- YES** : Go to step 10L12.
- NO** : Go to step 10L13.

10L12 : CHECK ABS SENSOR SIGNAL.

- 1) Raise all four wheels of ground.
- 2) Turn ignition switch OFF.
- 3) Connect the oscilloscope to the connector (F1) or connector (B100) in accordance with trouble code.
- 4) Turn ignition switch ON.
- 5) Rotate wheels and measure voltage at specified frequency.

NOTE:

When this inspection is completed, the ABSCM&H/U sometimes stores the trouble code 29.

Connector & terminal

Trouble code 22 / (B100) No. 12 (+) — No. 13 (-):

Trouble code 24 / (B100) No. 3 (+) — No. 4 (-):

Trouble code 26 / (F1) No. 5 (+) — No. 4 (-):

Trouble code 28 / (F1) No. 2 (+) — No. 1 (-):

Specified voltage: 0.12 — 1 V (When it is 20 Hz.)

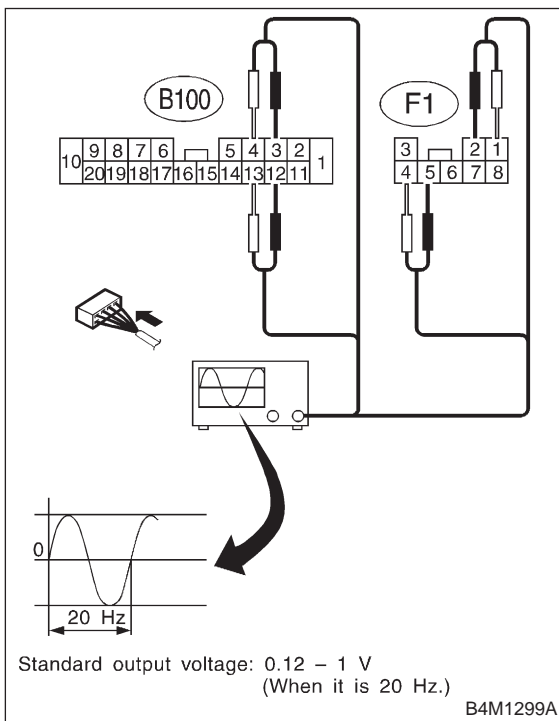

CHECK : *Is oscilloscope pattern smooth, as shown in figure?*

YES : Go to step 10L16.

NO : Go to step 10L13.

10L13 : CHECK CONTAMINATION OF ABS SENSOR OR TONE WHEEL.

Remove disc rotor or drum from hub in accordance with trouble code.

CHECK : *Is the ABS sensor pole piece or the tone wheel contaminated by dirt or other foreign matter?*

YES : Thoroughly remove dirt or other foreign matter.

NO : Go to step 10L14.

10L14 : CHECK DAMAGE OF ABS SENSOR OR TONE WHEEL.

CHECK : *Are there broken or damaged in the ABS sensor pole piece or the tone wheel?*

YES : Replace ABS sensor or tone wheel.

NO : Go to step 10L15.

10L15 : CHECK HUB RUNOUT.

Measure hub runout.

CHECK : *Is the runout less than 0.05 mm (0.0020 in)?*

YES : Go to step 10L16.

NO : Repair hub.

10L16 : CHECK RESISTANCE OF ABS SENSOR.

- 1) Turn ignition switch OFF.
- 2) Disconnect connector from ABS sensor.
- 3) Measure resistance between ABS sensor connector terminals.

Terminal

- Front RH No. 1 — No. 2:**
- Front LH No. 1 — No. 2:**
- Rear RH No. 1 — No. 2:**
- Rear LH No. 1 — No. 2:**

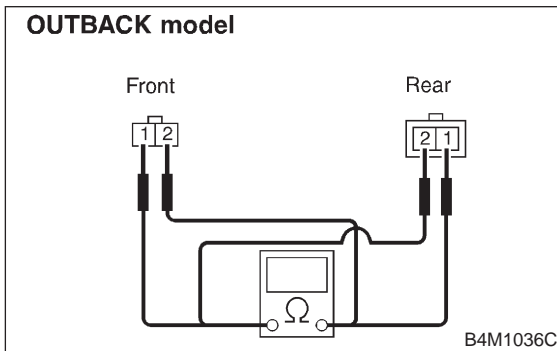
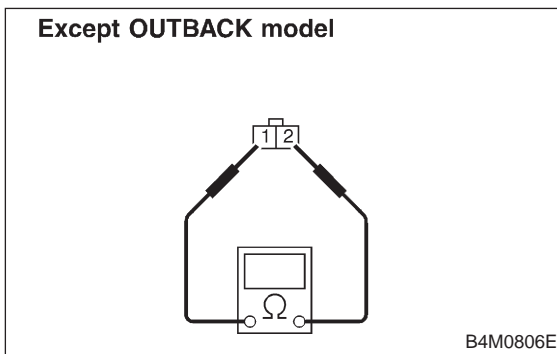

- CHECK** : Is the resistance between 0.8 and 1.2 kΩ?
- YES** : Go to step 10L17.
- NO** : Replace ABS sensor.

10L17 : CHECK GROUND SHORT OF ABS SENSOR.

Measure resistance between ABS sensor and chassis ground.

Terminal

- Front RH No. 1 — Chassis ground:**
- Front LH No. 1 — Chassis ground:**
- Rear RH No. 1 — Chassis ground:**
- Rear LH No. 1 — Chassis ground:**

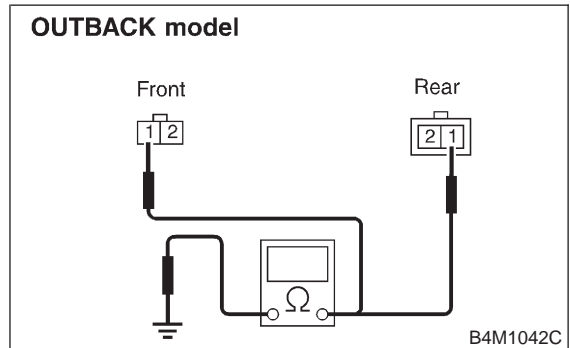
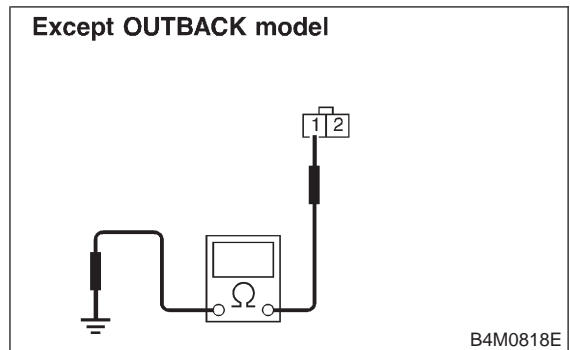

- CHECK** : Is the resistance more than 1 MΩ?
- YES** : Go to step 10L18.
- NO** : Replace ABS sensor.

10L18 : CHECK HARNESS/CONNECTOR BETWEEN ABSCM&H/U AND ABS SENSOR.

- 1) Connect connector to ABS sensor.
- 2) Disconnect connector from ABSCM&H/U.
- 3) Measure resistance at ABSCM&H/U connector terminals.

Connector & terminal

- Trouble code 22 / (F49) No. 11 — No. 12:**
- Trouble code 24 / (F49) No. 9 — No. 10:**
- Trouble code 26 / (F49) No. 14 — No. 15:**
- Trouble code 28 / (F49) No. 7 — No. 8:**

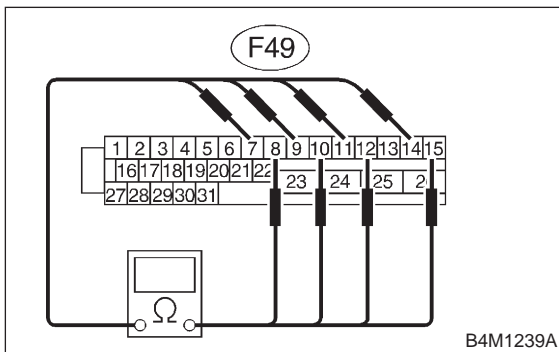

- CHECK** : Is the resistance between 0.8 and 1.2 kΩ?
- YES** : Go to step 10L19.
- NO** : Repair harness/connector between ABSCM&H/U and ABS sensor.

10L19 : CHECK GROUND SHORT OF HARNESS.

Measure resistance between ABSCM&H/U connector and chassis ground.

Connector & terminal

- Trouble code 22 / (F49) No. 11 — Chassis ground:**
- Trouble code 24 / (F49) No. 9 — Chassis ground:**
- Trouble code 26 / (F49) No. 14 — Chassis ground:**
- Trouble code 28 / (F49) No. 7 — Chassis ground:**

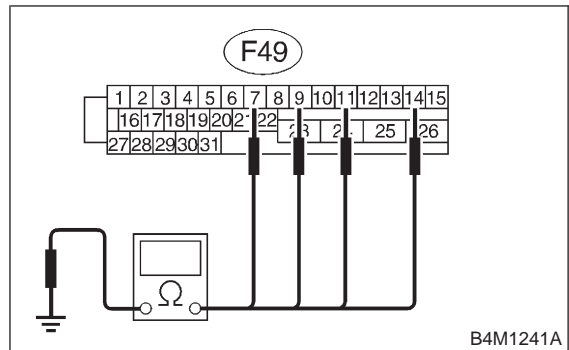

- CHECK** : Is the resistance more than 1 MΩ?
- YES** : Go to step 10L20.
- NO** : Repair harness/connector between ABSCM&H/U and ABS sensor.

10L20 : CHECK GROUND CIRCUIT OF ABSCM&H/U.

Measure resistance between ABSCM&H/U and chassis ground.

Connector & terminal

- (F49) No. 23 — GND:**

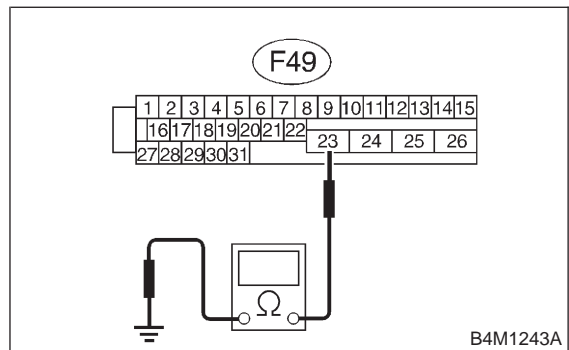

- CHECK** : Is the resistance less than 0.5 Ω?
- YES** : Go to step 10L21.
- NO** : Repair ABSCM&H/U ground harness.

4-4 [T10L21]

10. Diagnostics Chart with Select Monitor

BRAKES

10L21 : CHECK POOR CONTACT IN CONNECTORS.

CHECK : *Is there poor contact in connectors between ABSCM&H/U and ABS sensor? <Ref. to FOREWORD [T3C1].>*

YES : Repair connector.

NO : Go to step 10L22.

10L22 : CHECK SOURCES OF SIGNAL NOISE.

CHECK : *Is the car telephone or the wireless transmitter properly installed?*

YES : Go to step 10L23.

NO : Properly install the car telephone or the wireless transmitter.

10L23 : CHECK SOURCES OF SIGNAL NOISE.

CHECK : *Are noise sources (such as an antenna) installed near the sensor harness?*

YES : Install the noise sources apart from the sensor harness.

NO : Go to step 10L24.

10L24 : CHECK SHIELD CIRCUIT.

- 1) Connect all connectors.
- 2) Measure resistance between shield connector and chassis ground.

Connector & terminal

Trouble code 22 / (B100) No. 11 — Chassis ground:

Trouble code 24 / (B100) No. 2 — Chassis ground:

Trouble code 26 / Go to step 10L25.

Trouble code 28 / Go to step 10L25.

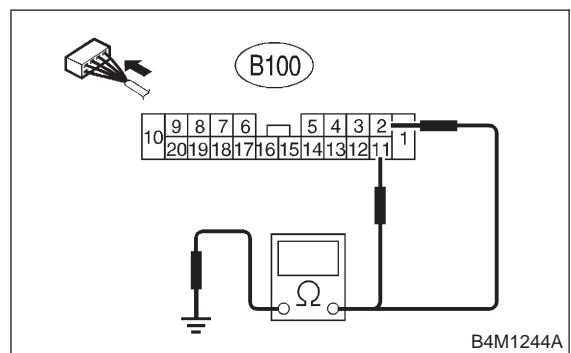

CHECK : *Is the resistance less than 0.5 Ω?*

YES : Go to step 10L25.

NO : Repair shield harness.

10L25 : CHECK ABSCM&H/U.

- 1) Connect all connectors.
- 2) Erase the memory.
- 3) Perform inspection mode.
- 4) Read out the trouble code.

CHECK : *Is the same trouble code as in the current diagnosis still being output?*

YES : Replace ABSCM&H/U.

NO : Go to step 10L26.

10L26 : CHECK ANY OTHER TROUBLE CODES APPEARANCE.

CHECK : *Are other trouble codes being output?*

YES : Proceed with the diagnosis corresponding to the trouble code.

NO : A temporary noise interference.

BRAKES

[T10L26] 4-4

10. Diagnostics Chart with Select Monitor

MEMO:

M: TROUBLE CODE 29 ABNORMAL ABS SENSOR SIGNAL ON ANY ONE OF FOUR SENSOR

— ABNORMAL ABS SENSOR SIGNAL ON ANY ONE OF FOUR —

DIAGNOSIS:

- Faulty ABS sensor signal (noise, irregular signal, etc.)
- Faulty tone wheel
- Wheels turning freely for a long time

TROUBLE SYMPTOM:

- ABS does not operate.

WIRING DIAGRAM:

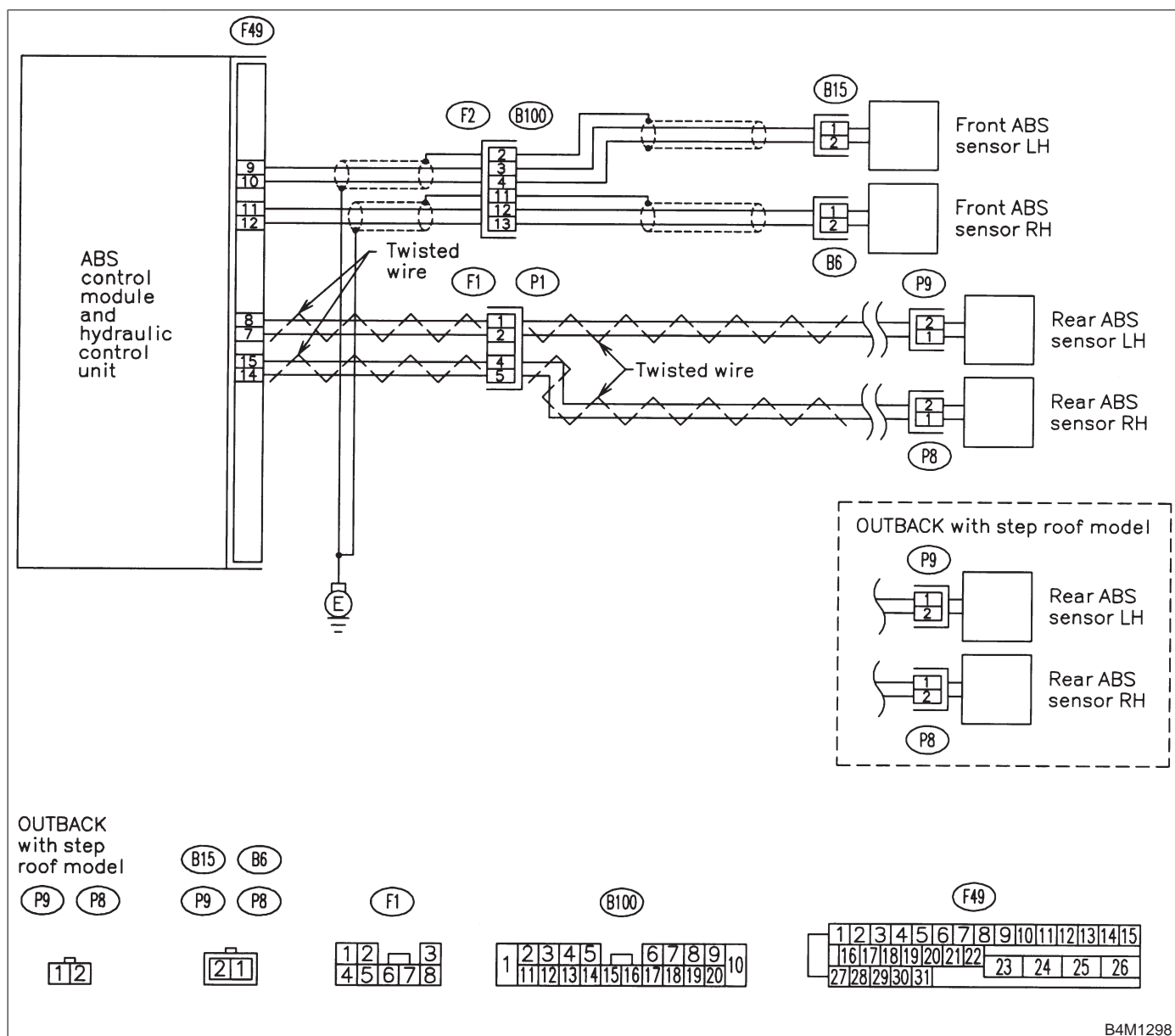

10M1 : CHECK IF THE WHEELS HAVE TURNED FREELY FOR A LONG TIME.

- CHECK** : Check if the wheels have been turned freely for more than one minute, such as when the vehicle is jacked-up, under full-lock cornering or when tire is not in contact with road surface.
- YES** : The ABS is normal. Erase the trouble code.

NOTE:

When the wheels turn freely for a long time, such as when the vehicle is towed or jacked-up, or when steering wheel is continuously turned all the way, this trouble code may sometimes occur.

- NO** : Go to step 10M2.

10M2 : CHECK TIRE SPECIFICATIONS.

Turn ignition switch to OFF.

- CHECK** : Are the tire specifications correct?
- YES** : Go to step 10M3.
- NO** : Replace tire.

10M3 : CHECK WEAR OF TIRE.

- CHECK** : Is the tire worn excessively?
- YES** : Replace tire.
- NO** : Go to step 10M4.

10M4 : CHECK TIRE PRESSURE.

- CHECK** : Is the tire pressure correct?
- YES** : Go to step 10M5.
- NO** : Adjust tire pressure.

10M5 : CHECK INSTALLATION OF ABS SENSOR.

Tightening torque:

32±10 N-m (3.3±1.0 kg-m, 24±7 ft-lb)

- CHECK** : Are the ABS sensor installation bolts tightened securely?
- YES** : Go to step 10M6.
- NO** : Tighten ABS sensor installation bolts securely.

10M6 : CHECK INSTALLATION OF TONE WHEEL.

Tightening torque:

13±3 N-m (1.3±0.3 kg-m, 9.4±2.2 ft-lb)

- CHECK** : Are the tone wheel installation bolts tightened securely?
- YES** : Go to step 10M7.
- NO** : Tighten tone wheel installation bolts securely.

10M7 : CHECK ABS SENSOR GAP.

Measure tone wheel to pole piece gap over entire perimeter of the wheel.

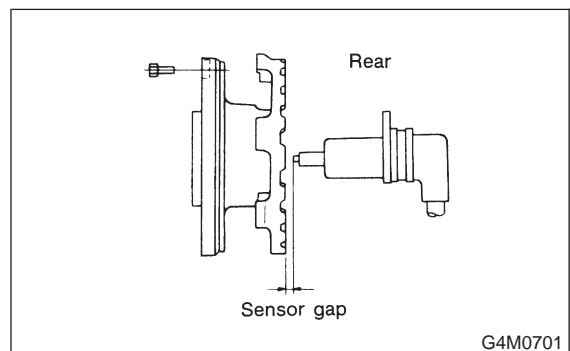
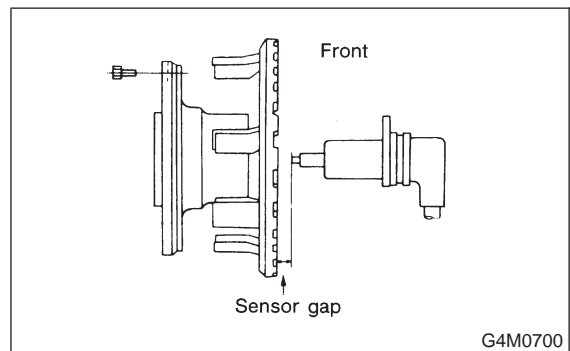

	Front wheel	Rear wheel
Specifications	0.9 — 1.4 mm (0.035 — 0.055 in)	0.7 — 1.2 mm (0.028 — 0.047 in)

- CHECK** : Is the gap within the specifications?
- YES** : Go to step 10M8.
- NO** : Adjust the gap.

NOTE:

Adjust the gap using spacer (Part No. 26755AA000). If spacers cannot correct the gap, replace worn sensor or worn tone wheel.

4-4 [T10M8]

10. Diagnostics Chart with Select Monitor

BRAKES

10M8 : CHECK OSCILLOSCOPE.

CHECK : *Is an oscilloscope available?*

YES : Go to step 10M9.

NO : Go to step 10M10.

10M9 : CHECK ABS SENSOR SIGNAL.

- 1) Raise all four wheels of ground.
- 2) Turn ignition switch OFF.
- 3) Connect the oscilloscope to the connector (B100) or connector (F1).
- 4) Turn ignition switch ON.
- 5) Rotate wheels and measure voltage at specified frequency.

NOTE:

When this inspection is completed, the ABSCM&H/U sometimes stores the trouble code 29.

Connector & terminal

(B100) No. 12 (+) — No. 13 (–) (Front RH):

(B100) No. 3 (+) — No. 4 (–) (Front LH):

(B100) No. 5 (+) — No. 4 (–) (Rear RH):

(B100) No. 2 (+) — No. 1 (–) (Rear LH):

Specified voltage: 0.12 — 1 V (When it is 20 Hz.)

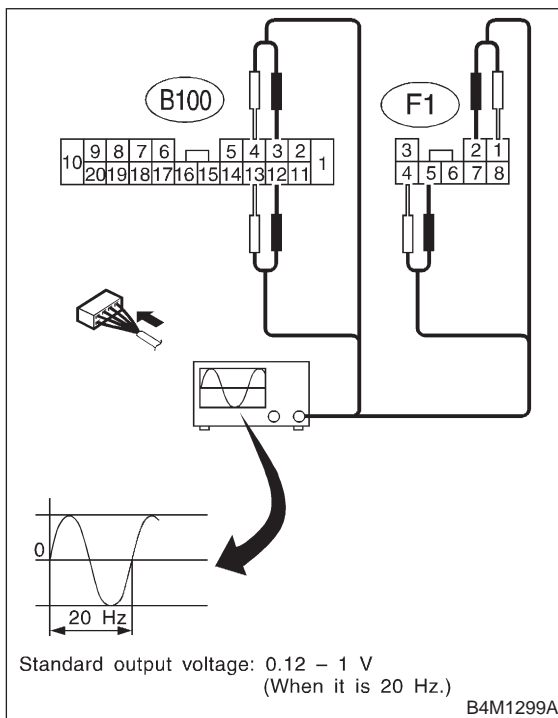

CHECK : *Is oscilloscope pattern smooth, as shown in figure?*

YES : Go to step 10M13.

NO : Go to step 10M10.

10M10 : CHECK CONTAMINATION OF ABS SENSOR OR TONE WHEEL.

Remove disc rotor from hub.

CHECK : *Is the ABS sensor pole piece or the tone wheel contaminated by dirt or other foreign matter?*

YES : Thoroughly remove dirt or other foreign matter.

NO : Go to step 10M11.

10M11 : CHECK DAMAGE OF ABS SENSOR OR TONE WHEEL.

CHECK : *Are there broken or damaged teeth in the ABS sensor pole piece or the tone wheel?*

YES : Replace ABS sensor or tone wheel.

NO : Go to step 10M12.

10M12 : CHECK HUB RUNOUT.

Measure hub runout.

CHECK : *Is the runout less than 0.05 mm (0.0020 in)?*

YES : Go to step 10M13.

NO : Repair hub.

10M13 : CHECK ABSCM&H/U.

- 1) Turn ignition switch to OFF.
- 2) Connect all connectors.
- 3) Erase the memory.
- 4) Perform inspection mode.
- 5) Read out the trouble code.

CHECK : *Is the same trouble code as in the current diagnosis still being output?*

YES : Replace ABSCM&H/U.

NO : Go to step 10M14.

10M14 : CHECK ANY OTHER TROUBLE CODES APPEARANCE.

CHECK : *Are other trouble codes being output?*

YES : Proceed with the diagnosis corresponding to the trouble code.

NO : A temporary poor contact.

BRAKES

[T10M14] 4-4

10. Diagnostics Chart with Select Monitor

MEMO:

N: TROUBLE CODE 31 FRONT RIGHT INLET VALVE MALFUNCTION

O: TROUBLE CODE 33 FRONT LEFT INLET VALVE MALFUNCTION

P: TROUBLE CODE 35 REAR RIGHT INLET VALVE MALFUNCTION

Q: TROUBLE CODE 37 REAR LEFT INLET VALVE MALFUNCTION

— INLET SOLENOID VALVE MALFUNCTION —

DIAGNOSIS:

- Faulty harness/connector
- Faulty inlet solenoid valve

TROUBLE SYMPTOM:

- ABS does not operate.

WIRING DIAGRAM:

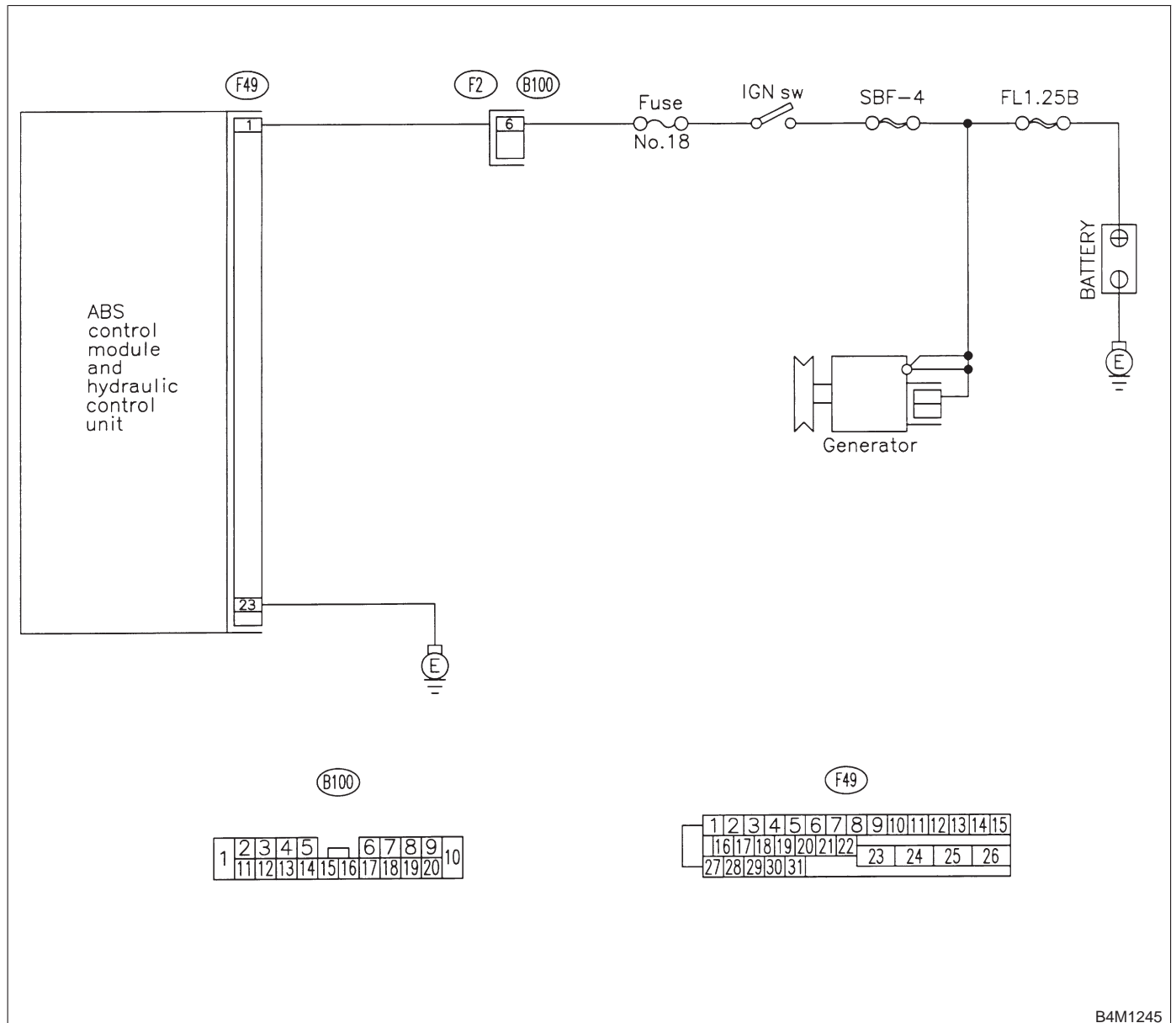

B4M1245

10Q1 : CHECK INPUT VOLTAGE OF ABSCM&H/U.

- 1) Turn ignition switch to OFF.
- 2) Disconnect connector from ABSCM&H/U.
- 3) Run the engine at idle.
- 4) Measure voltage between ABSCM&H/U connector and chassis ground.

Connector & terminal

(F49) No. 1 (+) — Chassis ground (-):

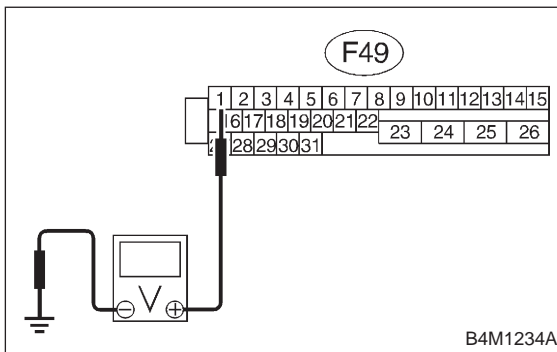

- CHECK** : **Is the voltage between 10 V and 15 V?**
- YES** : Go to step **10Q2**.
- NO** : Repair harness connector between battery, ignition switch and ABSCM&H/U.

10Q2 : CHECK GROUND CIRCUIT OF ABSCM&H/U.

- 1) Turn ignition switch to OFF.
- 2) Measure resistance between ABSCM&H/U connector and chassis ground.

Connector & terminal

(F49) No. 23 — Chassis ground:

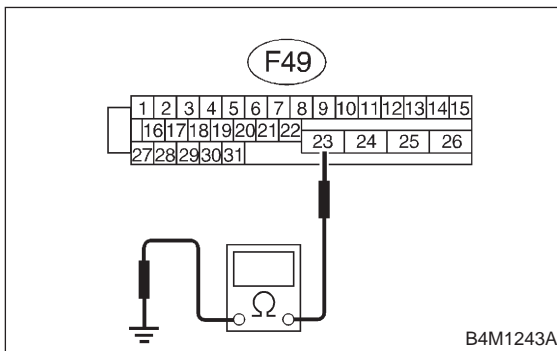

- CHECK** : **Is the resistance less than 0.5 Ω?**
- YES** : Go to step **10Q3**.
- NO** : Repair ABSCM&H/U ground harness.

10Q3 : CHECK POOR CONTACT IN CONNECTORS.

CHECK : **Is there poor contact in connectors between generator, battery and ABSCM&H/U? <Ref. to FOREWORD [T3C1].>**

- YES** : Repair connector.
- NO** : Go to step **10Q4**.

10Q4 : CHECK ABSCM&H/U.

- 1) Connect all connectors.
- 2) Erase the memory.
- 3) Perform inspection mode.
- 4) Read out the trouble code.

CHECK : **Is the same trouble code as in the current diagnosis still being output?**

- YES** : Replace ABSCM&H/U.
- NO** : Go to step **10Q5**.

10Q5 : CHECK ANY OTHER TROUBLE CODES APPEARANCE.

CHECK : **Are other trouble codes being output?**

- YES** : Proceed with the diagnosis corresponding to the trouble code.
- NO** : A temporary poor contact.

R: TROUBLE CODE 32 FRONT RIGHT OUTLET VALVE MALFUNCTION

S: TROUBLE CODE 34 FRONT LEFT OUTLET VALVE MALFUNCTION

T: TROUBLE CODE 36 REAR RIGHT OUTLET VALVE MALFUNCTION

U: TROUBLE CODE 38 REAR LEFT OUTLET VALVE MALFUNCTION

— OUTLET SOLENOID VALVE MALFUNCTION —

DIAGNOSIS:

- Faulty harness/connector
- Faulty outlet solenoid valve

TROUBLE SYMPTOM:

- ABS does not operate.

WIRING DIAGRAM:

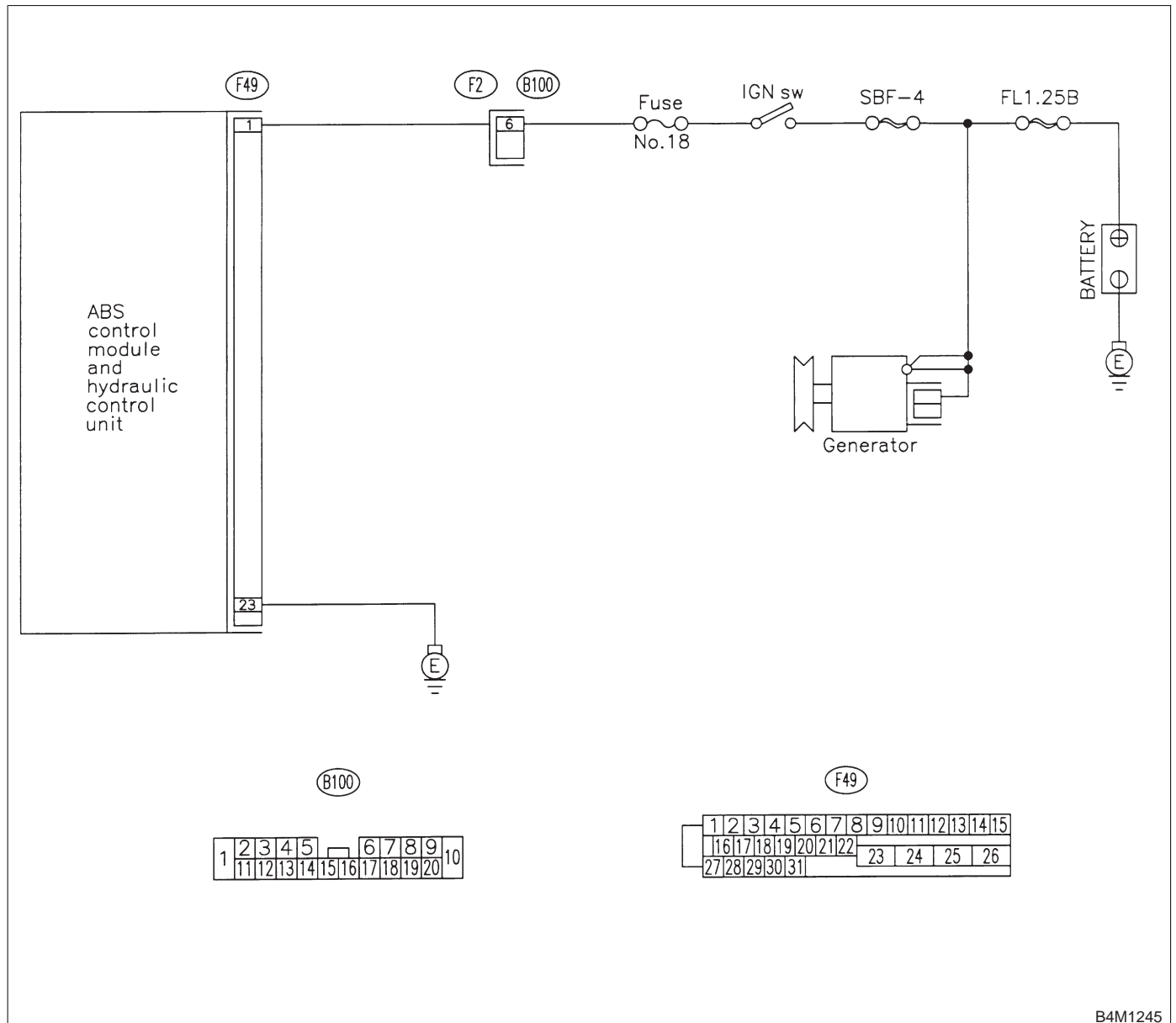

10U1 : CHECK INPUT VOLTAGE OF ABSCM&H/U.

- 1) Turn ignition switch to OFF.
- 2) Disconnect connector from ABSCM&H/U.
- 3) Run the engine at idle.
- 4) Measure voltage between ABSCM&H/U connector and chassis ground.

Connector & terminal

(F49) No. 1 (+) — Chassis ground (-):

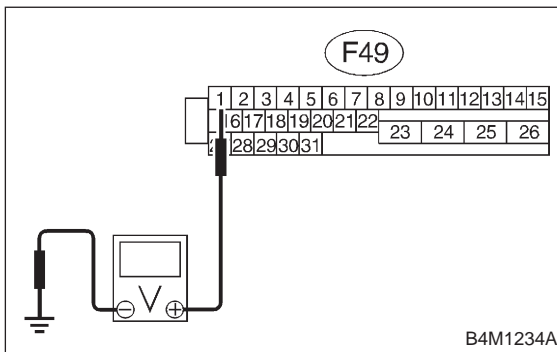

- CHECK** : **Is the voltage between 10 V and 15 V?**
- YES** : Go to step **10U2**.
- NO** : Repair harness connector between battery, ignition switch and ABSCM&H/U.

10U2 : CHECK GROUND CIRCUIT OF ABSCM&H/U.

- 1) Turn ignition switch to OFF.
- 2) Measure resistance between ABSCM&H/U connector and chassis ground.

Connector & terminal

(F49) No. 23 — Chassis ground:

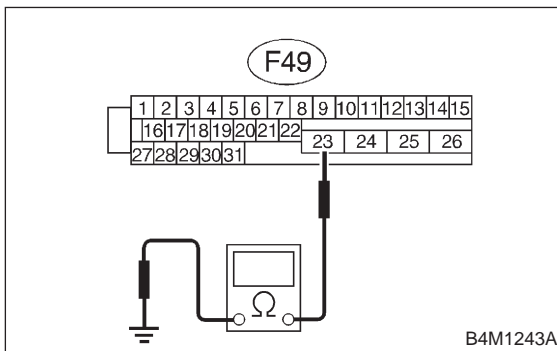

- CHECK** : **Is the resistance less than 0.5 Ω?**
- YES** : Go to step **10U3**.
- NO** : Repair ABSCM&H/U ground harness.

10U3 : CHECK POOR CONTACT IN CONNECTORS.

CHECK : **Is there poor contact in connectors between generator, battery and ABSCM&H/U? <Ref. to FOREWORD [T3C1].>**

- YES** : Repair connector.
- NO** : Go to step **10U4**.

10U4 : CHECK ABSCM&H/U.

- 1) Connect all connectors.
- 2) Erase the memory.
- 3) Perform inspection mode.
- 4) Read out the trouble code.

CHECK : **Is the same trouble code as in the current diagnosis still being output?**

- YES** : Replace ABSCM&H/U.
- NO** : Go to step **10U5**.

10U5 : CHECK ANY OTHER TROUBLE CODES APPEARANCE.

CHECK : **Are other trouble codes being output?**

- YES** : Proceed with the diagnosis corresponding to the trouble code.
- NO** : A temporary poor contact.

V: TROUBLE CODE 41 ABS CONTROL MODULE MALFUNCTION

— ABS CONTROL MODULE AND HYDRAULIC CONTROL UNIT MALFUNCTION—

DIAGNOSIS:

- Faulty ABSCM&H/U

TROUBLE SYMPTOM:

- ABS does not operate.

WIRING DIAGRAM:

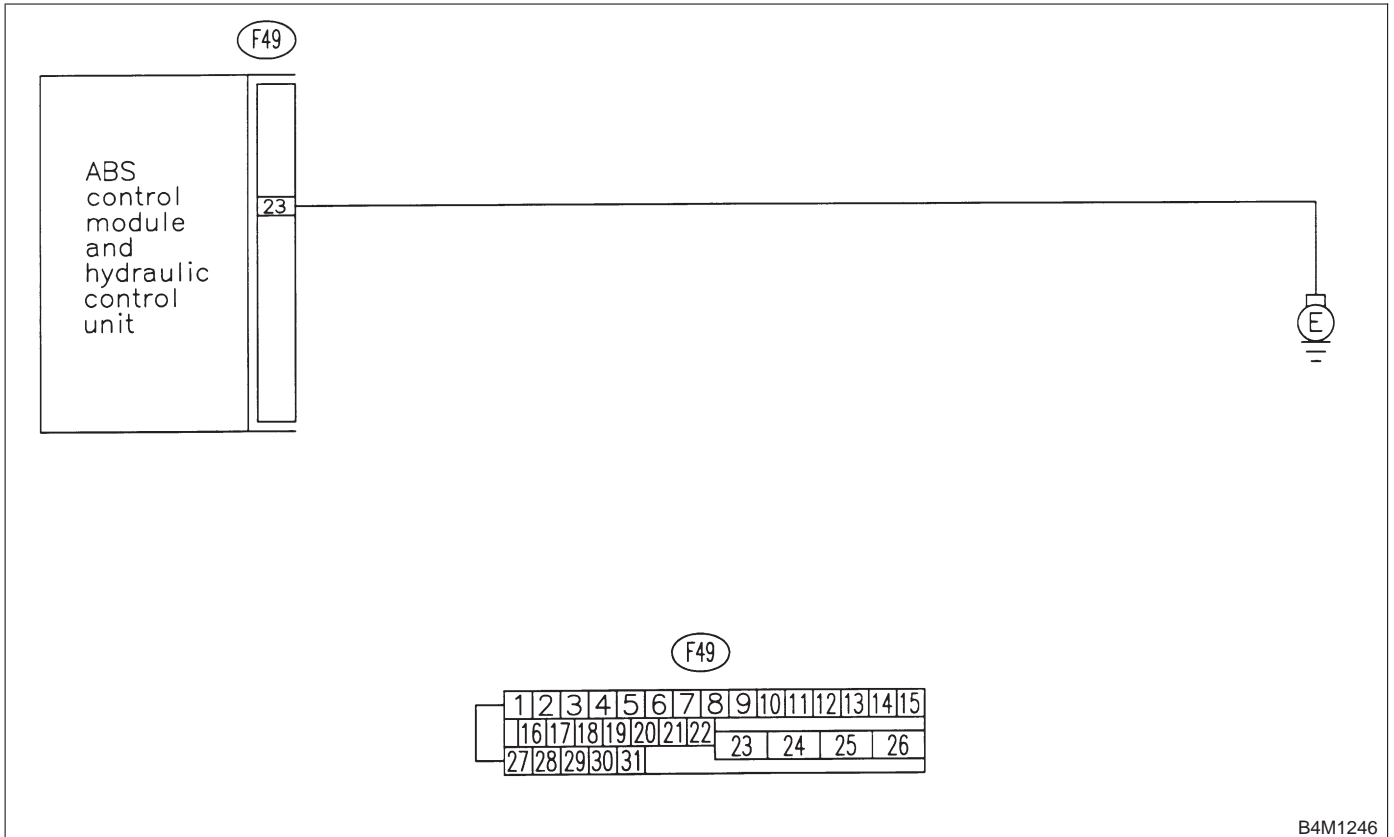

B4M1246

10V1 : CHECK GROUND CIRCUIT OF ABSCM&H/U.

- 1) Turn ignition switch to OFF.
- 2) Disconnect connector from ABSCM&H/U.
- 3) Measure resistance between ABSCM&H/U and chassis ground.

Connector & terminal
(F49) No. 23 — Chassis ground:

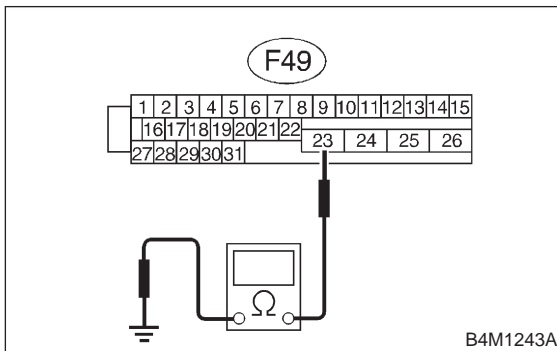

- CHECK** : *Is the resistance less than 0.5 Ω?*
- YES** : Go to step 10V2.
- NO** : Repair ABSCM&H/U ground harness.

10V2 : CHECK POOR CONTACT IN CONNECTORS.

- CHECK** : *Is there poor contact in connectors between battery, ignition switch and ABSCM&H/U? <Ref. to FOREWORD [T3C1].>*
- YES** : Repair connector.
- NO** : Go to step 10V3.

10V3 : CHECK SOURCES OF SIGNAL NOISE.

- CHECK** : *Is the car telephone or the wireless transmitter properly installed?*
- YES** : Go to step 10V4.
- NO** : Properly install the car telephone or the wireless transmitter.

10V4 : CHECK SOURCES OF SIGNAL NOISE.

- CHECK** : *Are noise sources (such as an antenna) installed near the sensor harness?*
- YES** : Install the noise sources apart from the sensor harness.
- NO** : Go to step 10V5.

10V5 : CHECK ABSCM&H/U.

- 1) Turn ignition switch to OFF.
 - 2) Connect all connectors.
 - 3) Erase the memory.
 - 4) Perform inspection mode.
 - 5) Read out the trouble code.
- CHECK** : *Is the same trouble code as in the current diagnosis still being output?*
- YES** : Replace ABSCM&H/U.
- NO** : Go to step 10V6.

10V6 : CHECK ANY OTHER TROUBLE CODES APPEARANCE.

- CHECK** : *Are other trouble codes being output?*
- YES** : Proceed with the diagnosis corresponding to the trouble code.
- NO** : A temporary poor contact.

W: TROUBLE CODE 42 POWER SUPPLY VOLTAGE TOO LOW

— POWER SUPPLY VOLTAGE TOO LOW —

DIAGNOSIS:

- Power source voltage of the ABSCM&H/U is low.

TROUBLE SYMPTOM:

- ABS does not operate.

WIRING DIAGRAM:

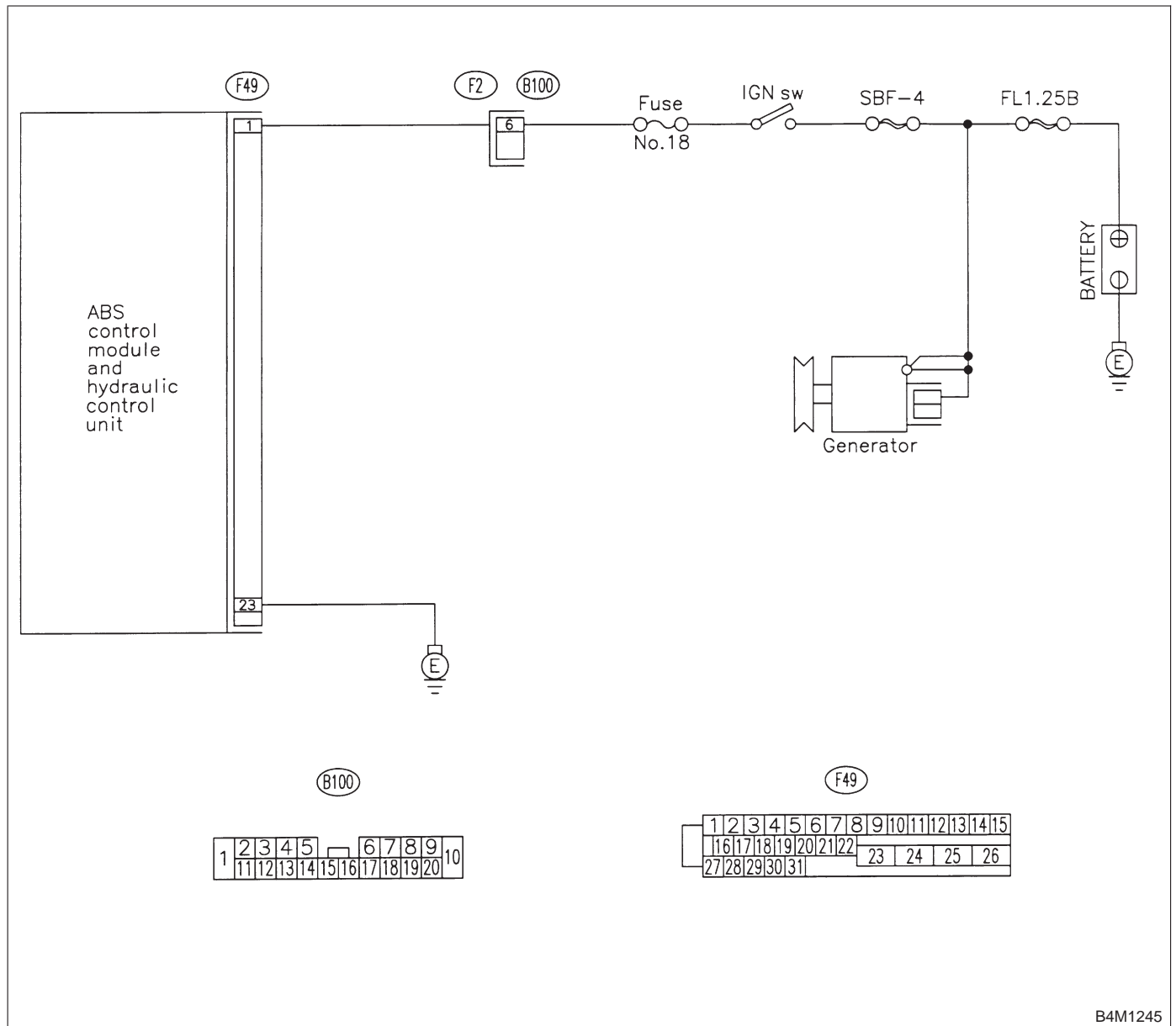

B4M1245

10W1 : CHECK GENERATOR.

- 1) Start engine.
- 2) Idling after warm-up.
- 3) Measure voltage between generator B terminal and chassis ground.

Terminal

Generator B terminal — Chassis ground:

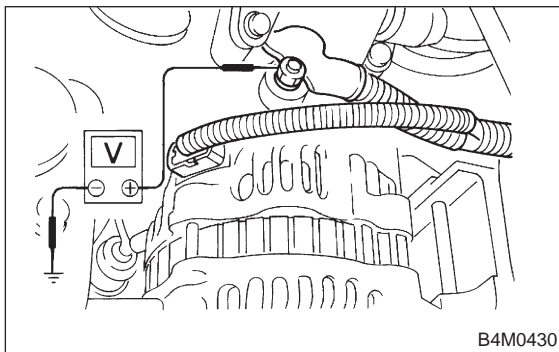

- CHECK** : *Is the voltage between 10 V and 15 V?*
- YES** : Go to step 10W2.
- NO** : Repair generator.

10W2 : CHECK BATTERY TERMINAL.

Turn ignition switch to OFF.

- CHECK** : *Are the positive and negative battery terminals tightly clamped?*
- YES** : Go to step 10W3.
- NO** : Tighten the clamp of terminal.

10W3 : CHECK INPUT VOLTAGE OF ABSCM&H/U.

- 1) Disconnect connector from ABSCM&H/U.
- 2) Run the engine at idle.
- 3) Measure voltage between ABSCM&H/U connector and chassis ground.

Connector & terminal

(F49) No. 1 (+) — Chassis ground (-):

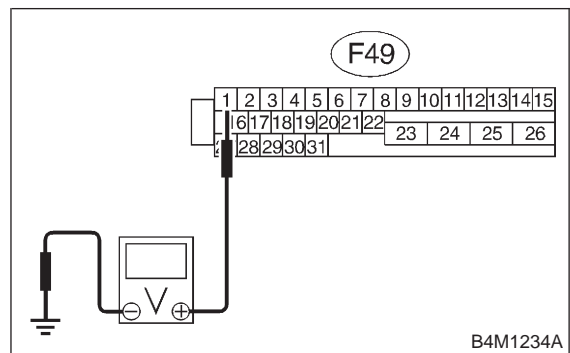

- CHECK** : *Is the voltage between 10 V and 15 V?*
- YES** : Go to step 10W4.
- NO** : Repair harness connector between battery, ignition switch and ABSCM&H/U.

10W4 : CHECK GROUND CIRCUIT OF ABSCM&H/U.

- 1) Turn ignition switch to OFF.
- 2) Measure resistance between ABSCM&H/U connector and chassis ground.

Connector & terminal

(F49) No. 23 — Chassis ground:

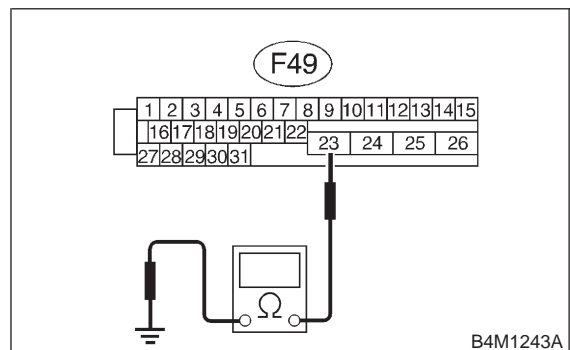

- CHECK** : *Is the resistance less than 0.5 Ω?*
- YES** : Go to step 10W5.
- NO** : Repair ABSCM&H/U ground harness.

10W5 : CHECK POOR CONTACT IN CONNECTORS.

CHECK : *Is there poor contact in connectors between generator, battery and ABSCM&H/U? <Ref. to FOREWORD [T3C1].>*

YES : Repair connector.

NO : Go to step **10W6**.

10W6 : CHECK ABSCM&H/U.

- 1) Connect all connectors.
- 2) Erase the memory.
- 3) Perform inspection mode.
- 4) Read out the trouble code.

CHECK : *Is the same trouble code as in the current diagnosis still being output?*

YES : Replace ABSCM&H/U.

NO : Go to step **10W7**.

10W7 : CHECK ANY OTHER TROUBLE CODES APPEARANCE.

CHECK : *Are other trouble codes being output?*

YES : Proceed with the diagnosis corresponding to the trouble code.

NO : A temporary poor contact.

BRAKES

[T10W7] 4-4

10. Diagnostics Chart with Select Monitor

MEMO:

X: TROUBLE CODE 42 POWER SUPPLY VOLTAGE TOO HIGH

— POWER SUPPLY VOLTAGE TOO HIGH —

DIAGNOSIS:

- Power source voltage of the ABSCM&H/U is high.

TROUBLE SYMPTOM:

- ABS does not operate.

WIRING DIAGRAM:

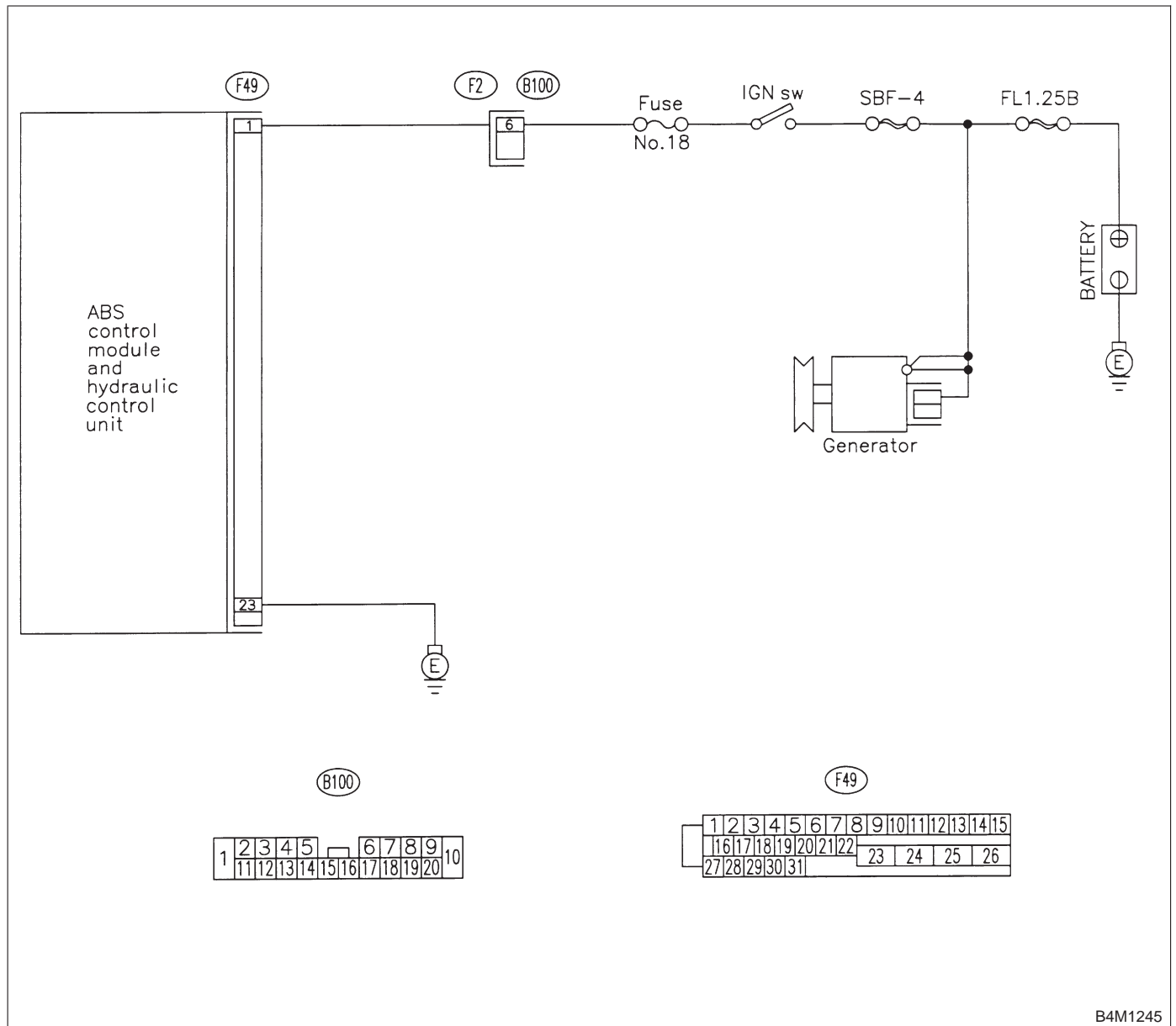

10X1 : CHECK GENERATOR.

- 1) Start engine.
- 2) Idling after warm-up.
- 3) Measure voltage between generator B terminal and chassis ground.

Terminal

Generator B terminal — Chassis ground:

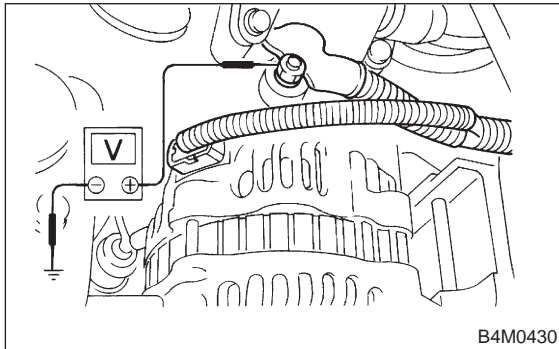

B4M0430

- CHECK** : *Is the voltage between 10 V and 17 V?*
- YES** : Go to step 10X2.
- NO** : Repair generator.

10X2 : CHECK BATTERY TERMINAL.

Turn ignition switch to OFF.

- CHECK** : *Are the positive and negative battery terminals tightly clamped?*
- YES** : Go to step 10X3.
- NO** : Tighten the clamp of terminal.

10X3 : CHECK INPUT VOLTAGE OF ABSCM&H/U.

- 1) Disconnect connector from ABSCM&H/U.
- 2) Run the engine at idle.
- 3) Measure voltage between ABSCM&H/U connector and chassis ground.

Connector & terminal

(F49) No. 1 (+) — Chassis ground (-):

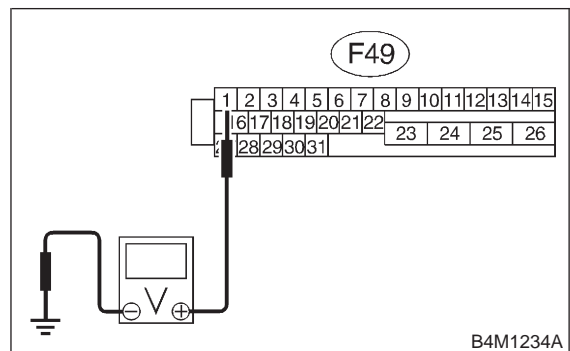

B4M1234A

- CHECK** : *Is the voltage between 10 V and 17 V?*
- YES** : Go to step 10X4.
- NO** : Repair harness connector between battery, ignition switch and ABSCM&H/U.

10X4 : CHECK GROUND CIRCUIT OF ABSCM&H/U.

- 1) Turn ignition switch to OFF.
- 2) Measure resistance between ABSCM&H/U connector and chassis ground.

Connector & terminal

(F49) No. 23 — Chassis ground:

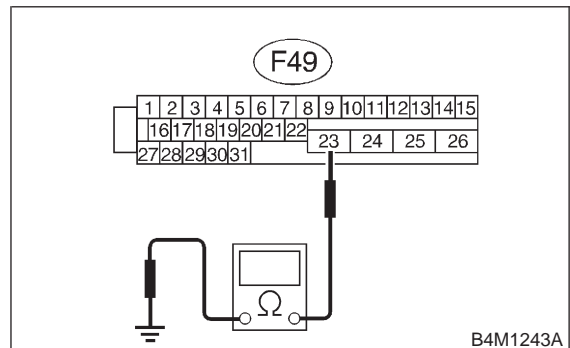

B4M1243A

- CHECK** : *Is the resistance less than 0.5 Ω?*
- YES** : Go to step 10X5.
- NO** : Repair ABSCM&H/U ground harness.

10X5 : CHECK POOR CONTACT IN CONNECTORS.

CHECK : *Is there poor contact in connectors between generator, battery and ABSCM&H/U? <Ref. to FOREWORD [T3C1].>*

YES : Repair connector.

NO : Go to step **10X6**.

10X6 : CHECK ABSCM&H/U.

- 1) Connect all connectors.
- 2) Erase the memory.
- 3) Perform inspection mode.
- 4) Read out the trouble code.

CHECK : *Is the same trouble code as in the current diagnosis still being output?*

YES : Replace ABSCM&H/U.

NO : Go to step **10X7**.

10X7 : CHECK ANY OTHER TROUBLE CODES APPEARANCE.

CHECK : *Are other trouble codes being output?*

YES : Proceed with the diagnosis corresponding to the trouble code.

NO : A temporary poor contact.

BRAKES

[T10X7] 4-4

10. Diagnostics Chart with Select Monitor

MEMO:

Y: TROUBLE CODE 44 ABS-AT CONTROL (NON CONTROLLED)

— ABS-AT CONTROL (NON CONTROLLED) —

DIAGNOSIS:

- Combination of AT control faults

TROUBLE SYMPTOM:

- ABS does not operate.

WIRING DIAGRAM:

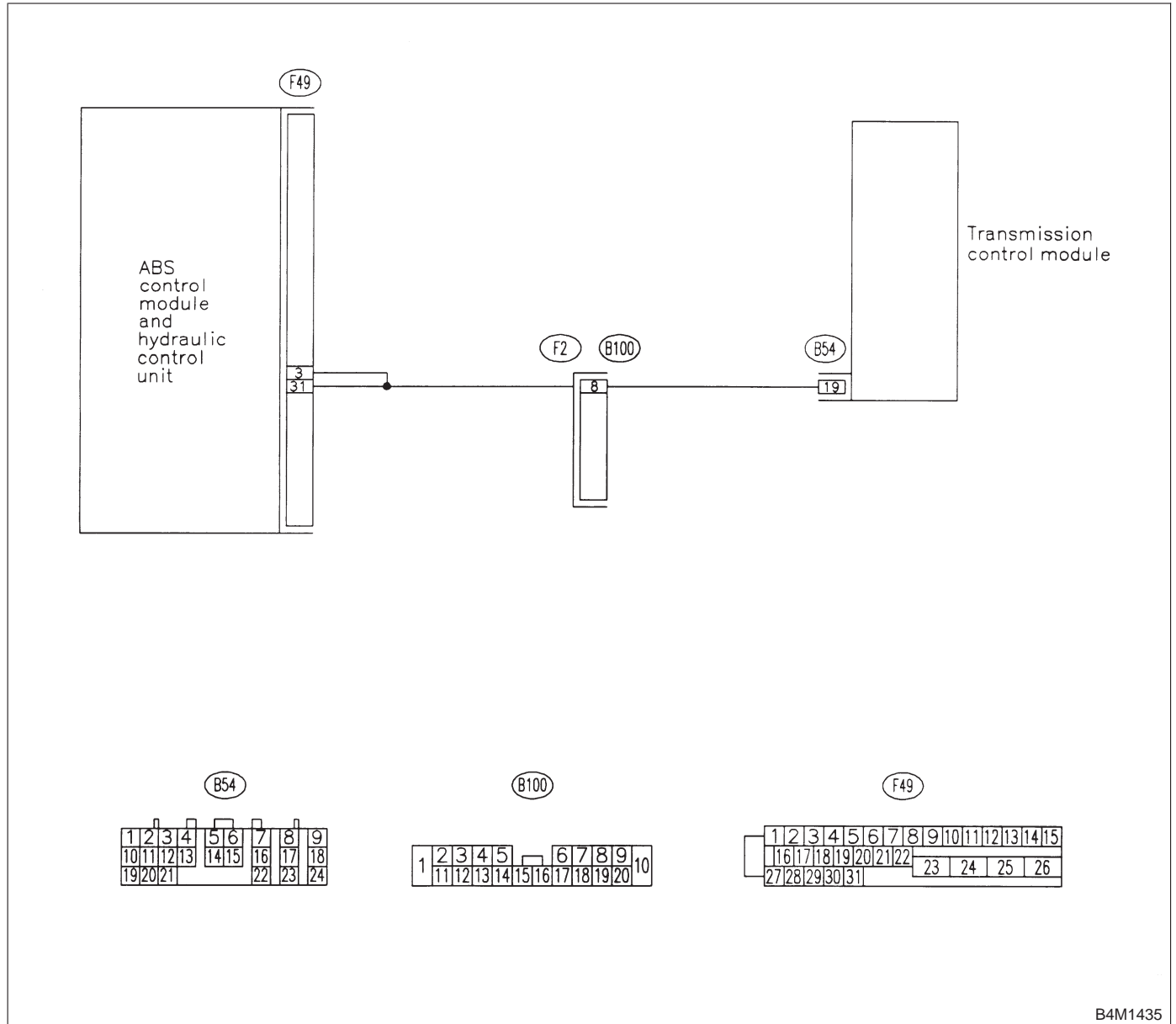

B4M1435

10Y1 : CHECK SPECIFICATIONS OF THE ABSCM&H/U.

Check specifications of the mark to the ABSCM&H/U.

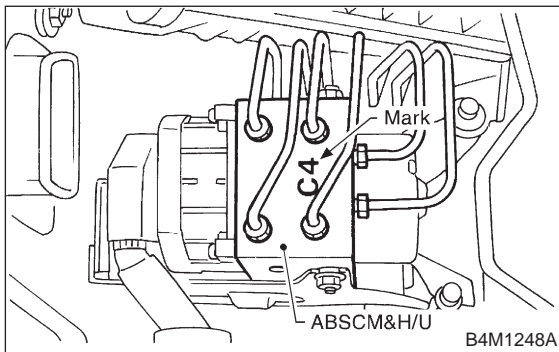

Mark	Model
C5	AWD AT
C6	AWD MT

- CHECK** : Is an ABSCM&H/U for AT model installed on a MT model?
- YES** : Replace ABSCM&H/U. <Ref. to 4-4 [W15A0].>
- NO** : Go to step 10Y2.

10Y2 : CHECK GROUND SHORT OF HARNESS.

- 1) Turn ignition switch to OFF.
- 2) Disconnect two connectors from TCM.
- 3) Disconnect connector from ABSCM&H/U.
- 4) Measure resistance between ABSCM&H/U connector and chassis ground.

Connector & terminal
(F49) No. 3 — Chassis ground:

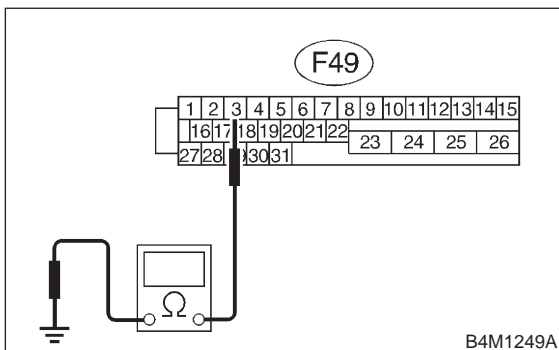

- CHECK** : Is the resistance more than 1 MΩ?
- YES** : Go to step 10Y3.
- NO** : Repair harness between TCM and ABSCM&H/U.

10Y3 : CHECK TCM.

- 1) Connect all connectors to TCM.
- 2) Turn ignition switch to ON.
- 3) Measure voltage between TCM connector terminal and chassis ground.

Connector & terminal
(B54) No. 19 (+) — Chassis ground (-):

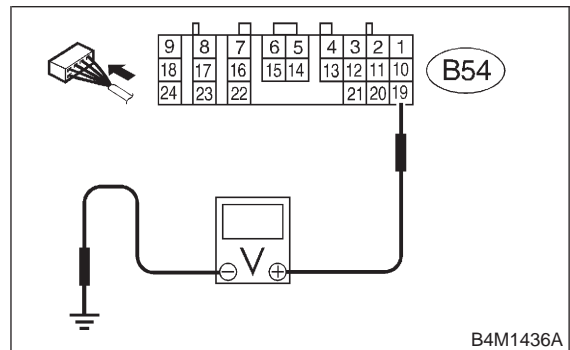

- CHECK** : Is the voltage between 10 V and 15 V?
- YES** : Go to step 10Y5.
- NO** : Go to step 10Y4.

10Y4 : CHECK AT.

- CHECK** : Is the AT functioning normally?
- YES** : Replace TCM. <Ref. to 3-2 [W22A0].>
- NO** : Repair AT. <Ref. to 3-2 [T6A0].>

4-4 [T10Y5]

10. Diagnostics Chart with Select Monitor

BRAKES

10Y5 : CHECK OPEN CIRCUIT OF HARNESS.

Measure voltage between ABSCM&H/U connector and chassis ground.

Connector & terminal

(F49) No. 3 (+) — Chassis ground (-):

(F49) No. 31 (+) — Chassis ground (-):

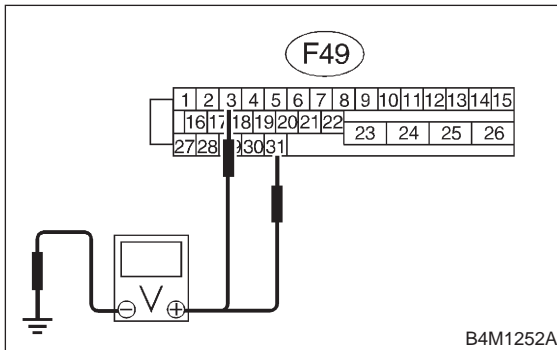

CHECK : *Is the voltage more than 10 V?*

YES : Go to step 10Y6.

NO : Repair harness/connector between AT control module and ABSCM&H/U.

10Y6 : CHECK POOR CONTACT IN CONNECTORS.

CHECK : *Is there poor contact in connectors between AT control module and ABSCM&H/U? <Ref. to FOREWORD [T3C1].>*

YES : Repair connector.

NO : Go to step 10Y7.

10Y7 : CHECK ABSCM&H/U.

- 1) Connect all connectors.
- 2) Erase the memory.
- 3) Perform inspection mode.
- 4) Read out the trouble code.

CHECK : *Is the same trouble code as in the current diagnosis still being output?*

YES : Replace ABSCM&H/U. <Ref. to 4-4 [W15A0].>

NO : Go to step 10Y8.

10Y8 : CHECK ANY OTHER TROUBLE CODES APPEARANCE.

CHECK : *Are other trouble codes being output?*

YES : Proceed with the diagnosis corresponding to the trouble code.

NO : A temporary poor contact.

BRAKES

[T10Y8] 4-4
10. Diagnostics Chart with Select Monitor

MEMO:

Z: TROUBLE CODE 44 ABS-AT CONTROL (CONTROLLED)

— ABS-AT CONTROL (CONTROLLED) —

DIAGNOSIS:

- Combination of AT control faults

TROUBLE SYMPTOM:

- ABS does not operate.

WIRING DIAGRAM:

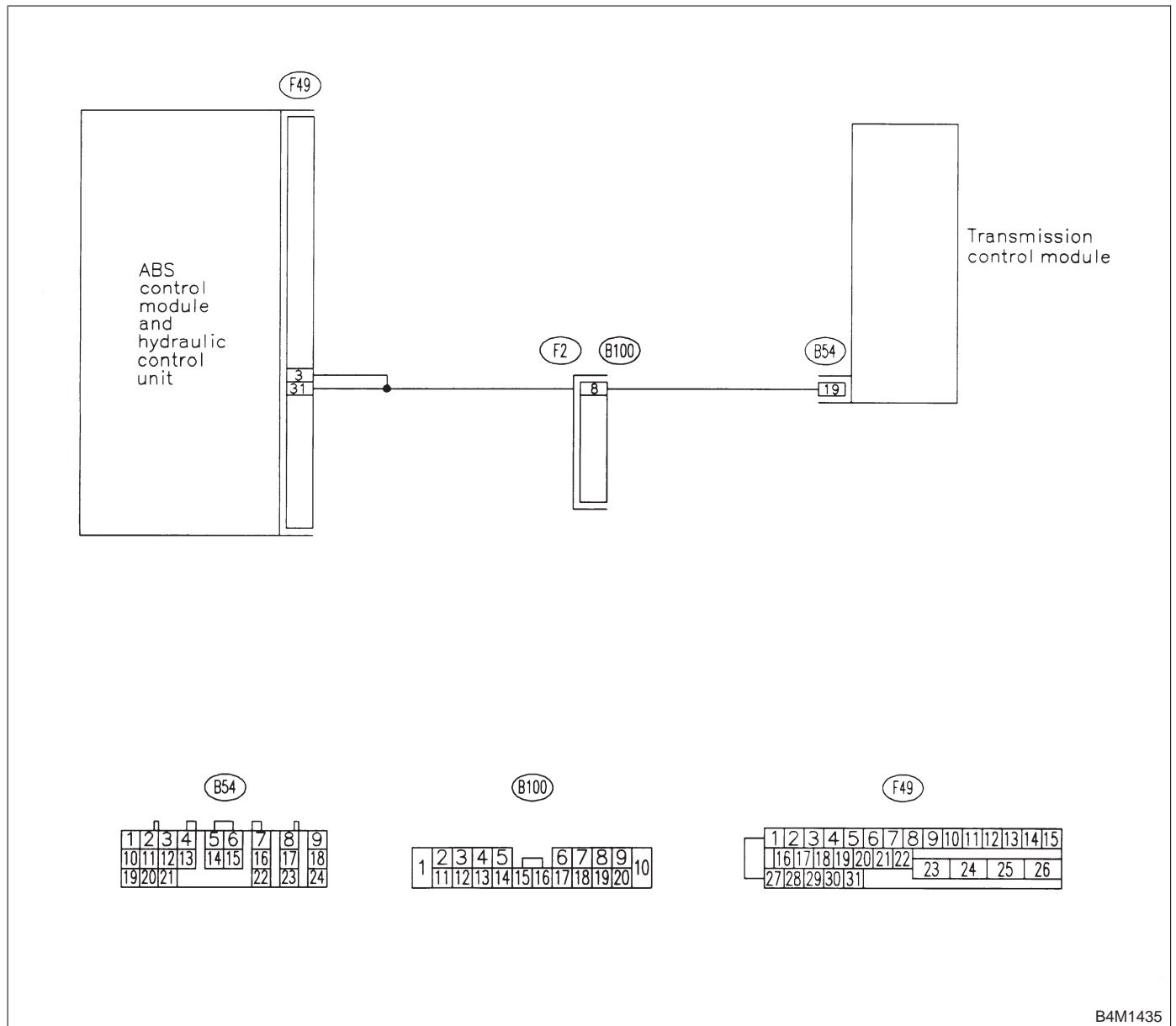

B4M1435

10Z1 : CHECK BATTERY SHORT OF HARNESS.

- 1) Turn ignition switch to OFF.
- 2) Disconnect two connectors from AT control module.
- 3) Disconnect connector from ABSCM&H/U.
- 4) Measure voltage between ABSCM&H/U connector and chassis ground.

Connector & terminal
(F49) No. 3 (+) — Chassis ground (-):

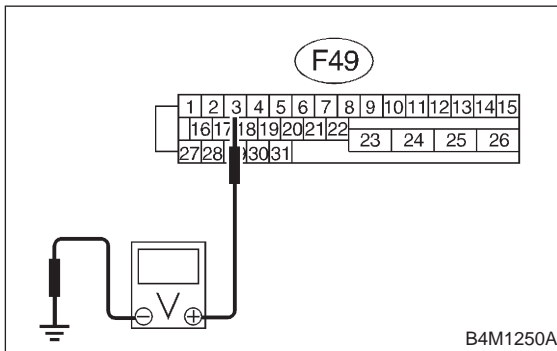

- CHECK** : **Is the voltage less than 1 V?**
- YES** : Go to step **10Z2**.
- NO** : Repair harness between AT control module and ABSCM&H/U.

10Z2 : CHECK BATTERY SHORT OF HARNESS.

- 1) Turn ignition switch to ON.
- 2) Measure voltage between ABSCM&H/U connector and chassis ground.

Connector & terminal
(F49) No. 3 (+) — Chassis ground (-):

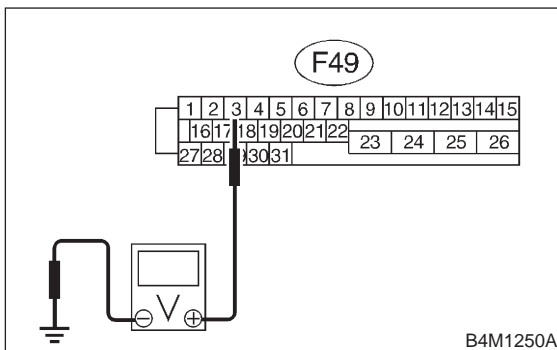

- CHECK** : **Is the voltage less than 1 V?**
- YES** : Go to step **10Z3**.
- NO** : Repair harness between AT control module and ABSCM&H/U.

10Z3 : CHECK OPEN CIRCUIT OF HARNESS.

- 1) Turn ignition switch to OFF.
- 2) Connect all connectors to TCM.
- 3) Turn ignition switch to ON.
- 4) Measure voltage between ABSCM&H/U connector and chassis ground.

Connector & terminal
(F49) No. 3 (+) — Chassis ground (-):
(F49) No. 31 (+) — Chassis ground (-):

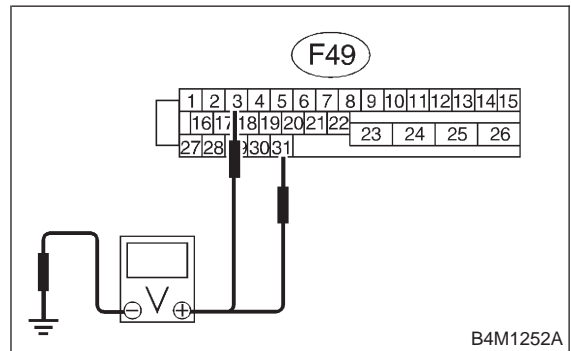

- CHECK** : **Is the voltage between 10 V and 13 V?**
- YES** : Go to step **10Z4**.
- NO** : Repair harness/connector between TCM and ABSCM&H/U.

10Z4 : CHECK POOR CONTACT IN CONNECTORS.

Turn ignition switch to OFF.

- CHECK** : **Is there poor contact in connectors between AT control module and ABSCM&H/U? <Ref. to FOREWORD [T3C1].>**
- YES** : Repair connector.
- NO** : Go to step **10Z5**.

10Z5 : CHECK ABSCM&H/U.

- 1) Connect all connectors.
- 2) Erase the memory.
- 3) Perform inspection mode.
- 4) Read out the trouble code.

- CHECK** : **Is the same trouble code as in the current diagnosis still being output?**
- YES** : Replace ABSCM&H/U. <Ref. to 4-4 [W15A0].>
- NO** : Go to step **10Z6**.

10Z6 : CHECK ANY OTHER TROUBLE CODES APPEARANCE.

- CHECK** : *Are other trouble codes being output?*
- YES** : Proceed with the diagnosis corresponding to the trouble code.
- NO** : A temporary poor contact.

BRAKES

[T10Z6] 4-4

10. Diagnostics Chart with Select Monitor

MEMO:

AA: TROUBLE CODE 51 VALVE RELAY MALFUNCTION

— VALVE RELAY MALFUNCTION —

DIAGNOSIS:

- Faulty valve relay

TROUBLE SYMPTOM:

- ABS does not operate.

WIRING DIAGRAM:

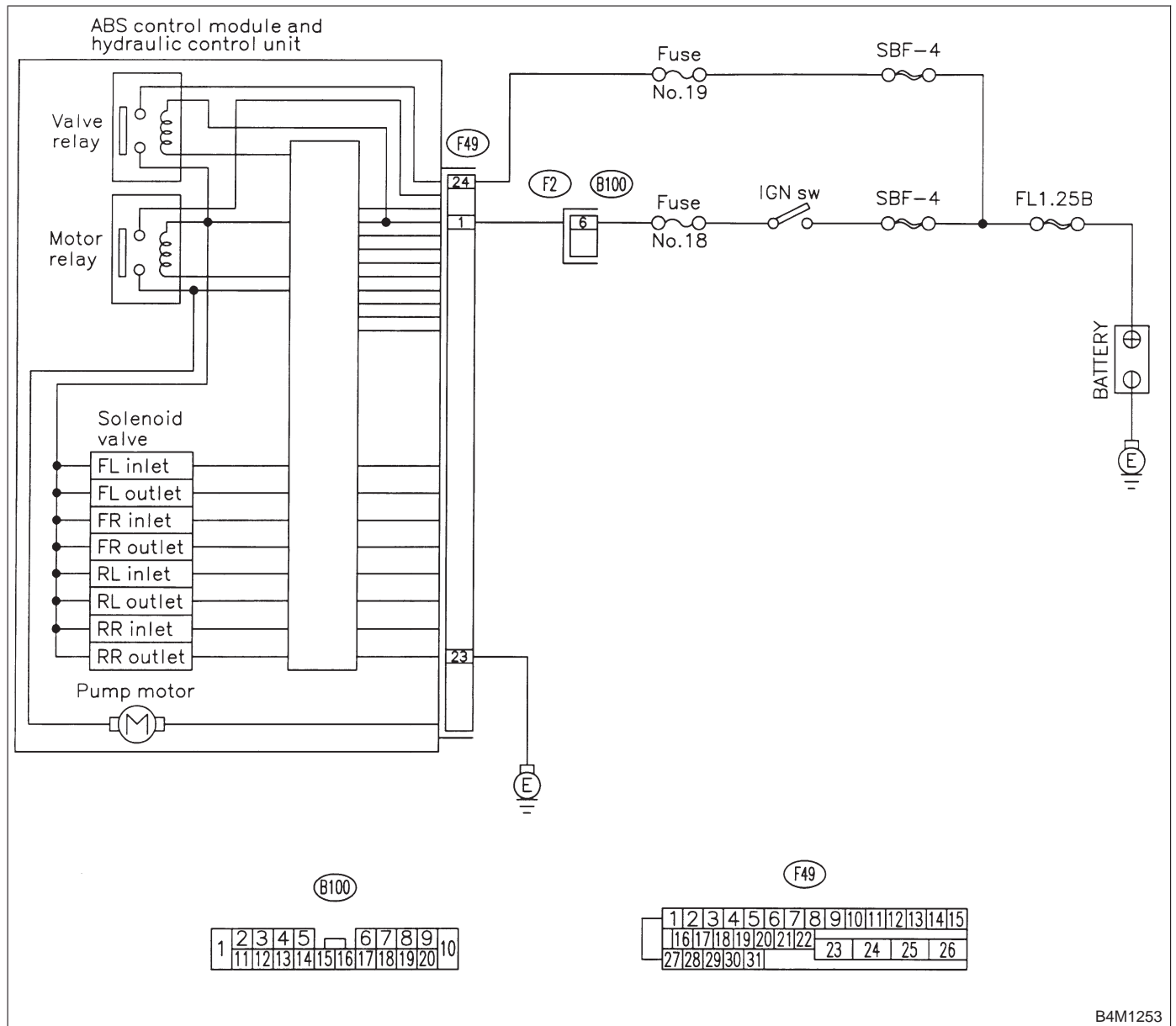

B4M1253

10AA1 : CHECK INPUT VOLTAGE OF ABSCM&H/U.

- 1) Turn ignition switch to OFF.
- 2) Disconnect connector from ABSCM&H/U.
- 3) Run the engine at idle.
- 4) Measure voltage between ABSCM&H/U connector and chassis ground.

Connector & terminal

(F49) No. 1 (+) — Chassis ground (-):
(F49) No. 24 (+) — Chassis ground (-):

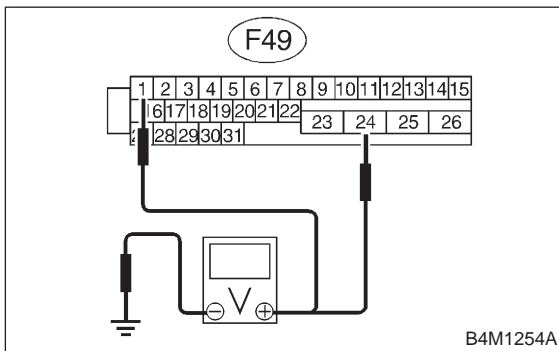

- CHECK** : **Is the voltage between 10 V and 15 V?**
- YES** : Go to step 10AA2.
- NO** : Repair harness connector between battery and ABSCM&H/U.

10AA2 : CHECK GROUND CIRCUIT OF ABSCM&H/U.

- 1) Turn ignition switch to OFF.
- 2) Measure resistance between ABSCM&H/U connector and chassis ground.

Connector & terminal

(F49) No. 23 — Chassis ground:

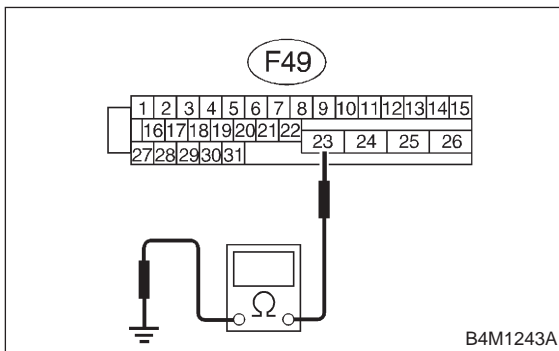

- CHECK** : **Is the resistance less than 0.5 Ω?**
- YES** : Go to step 10AA3.
- NO** : Repair ABSCM&H/U ground harness.

10AA3 : CHECK POOR CONTACT IN CONNECTORS.

- CHECK** : **Is there poor contact in connectors between generator, battery and ABSCM&H/U? <Ref. to FOREWORD [T3C1].>**
- YES** : Repair connector.
- NO** : Go to step 10AA4.

10AA4 : CHECK ABSCM&H/U.

- 1) Connect all connectors.
 - 2) Erase the memory.
 - 3) Perform inspection mode.
 - 4) Read out the trouble code.
- CHECK** : **Is the same trouble code as in the current diagnosis still being output?**
- YES** : Replace ABSCM&H/U.
- NO** : Go to step 10AA5.

10AA5 : CHECK ANY OTHER TROUBLE CODES APPEARANCE.

- CHECK** : **Are other trouble codes being output?**
- YES** : Proceed with the diagnosis corresponding to the trouble code.
- NO** : A temporary poor contact.

AB: TROUBLE CODE 51 VALVE RELAY ON FAILURE

— VALVE RELAY ON FAILURE —

DIAGNOSIS:

- Faulty valve relay

TROUBLE SYMPTOM:

- ABS does not operate.

WIRING DIAGRAM:

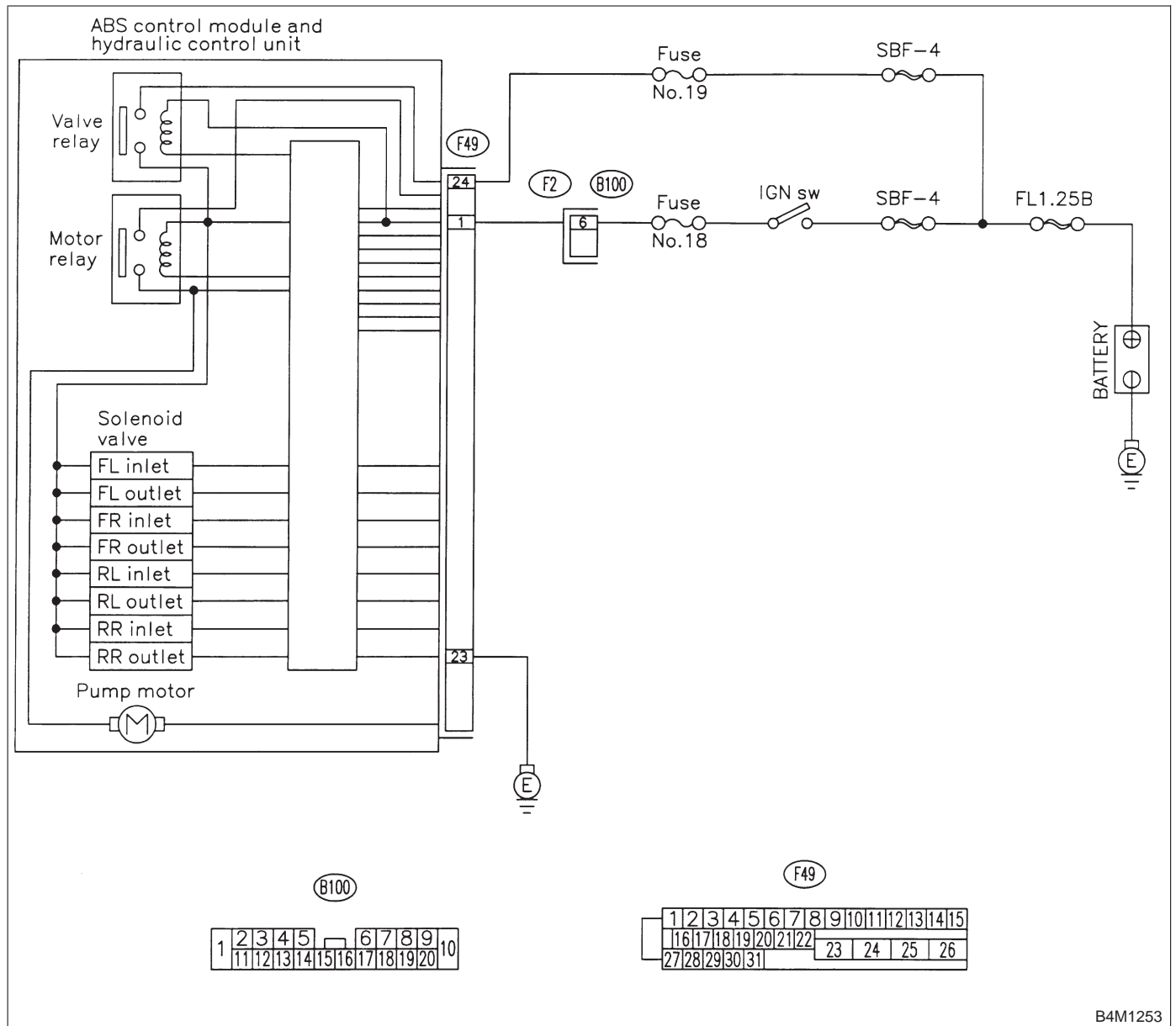

B4M1253

10AB1 : CHECK VALVE RELAY IN ABSCM&H/U.

Measure resistance between ABSCM&H/U terminals.

Terminals

No. 23 (+) — No. 24 (-):

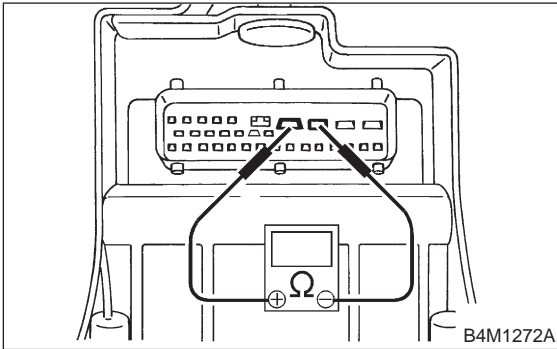

- CHECK** : *Is the resistance more than 1 MΩ?*
- YES** : Go to step **10AB2**.
- NO** : Replace ABSCM&H/U.

10AB2 : CHECK POOR CONTACT IN CONNECTORS.

- CHECK** : *Is there poor contact in connectors between generator, battery and ABSCM&H/U? <Ref. to FOREWORD [T3C1].>*
- YES** : Repair connector.
- NO** : Go to step **10AB3**.

10AB3 : CHECK ABSCM&H/U.

- 1) Connect all connectors.
- 2) Erase the memory.
- 3) Perform inspection mode.
- 4) Read out the trouble code.

- CHECK** : *Is the same trouble code as in the current diagnosis still being output?*
- YES** : Replace ABSCM&H/U.
- NO** : Go to step **10AB4**.

10AB4 : CHECK ANY OTHER TROUBLE CODES APPEARANCE.

- CHECK** : *Are other trouble codes being output?*
- YES** : Proceed with the diagnosis corresponding to the trouble code.
- NO** : A temporary poor contact.

AC: TROUBLE CODE 52 OPEN CIRCUIT IN MOTOR RELAY CIRCUIT

— OPEN CIRCUIT IN MOTOR RELAY CIRCUIT —

DIAGNOSIS:

- Faulty motor
- Faulty motor relay
- Faulty harness connector

TROUBLE SYMPTOM:

- ABS does not operate.

WIRING DIAGRAM:

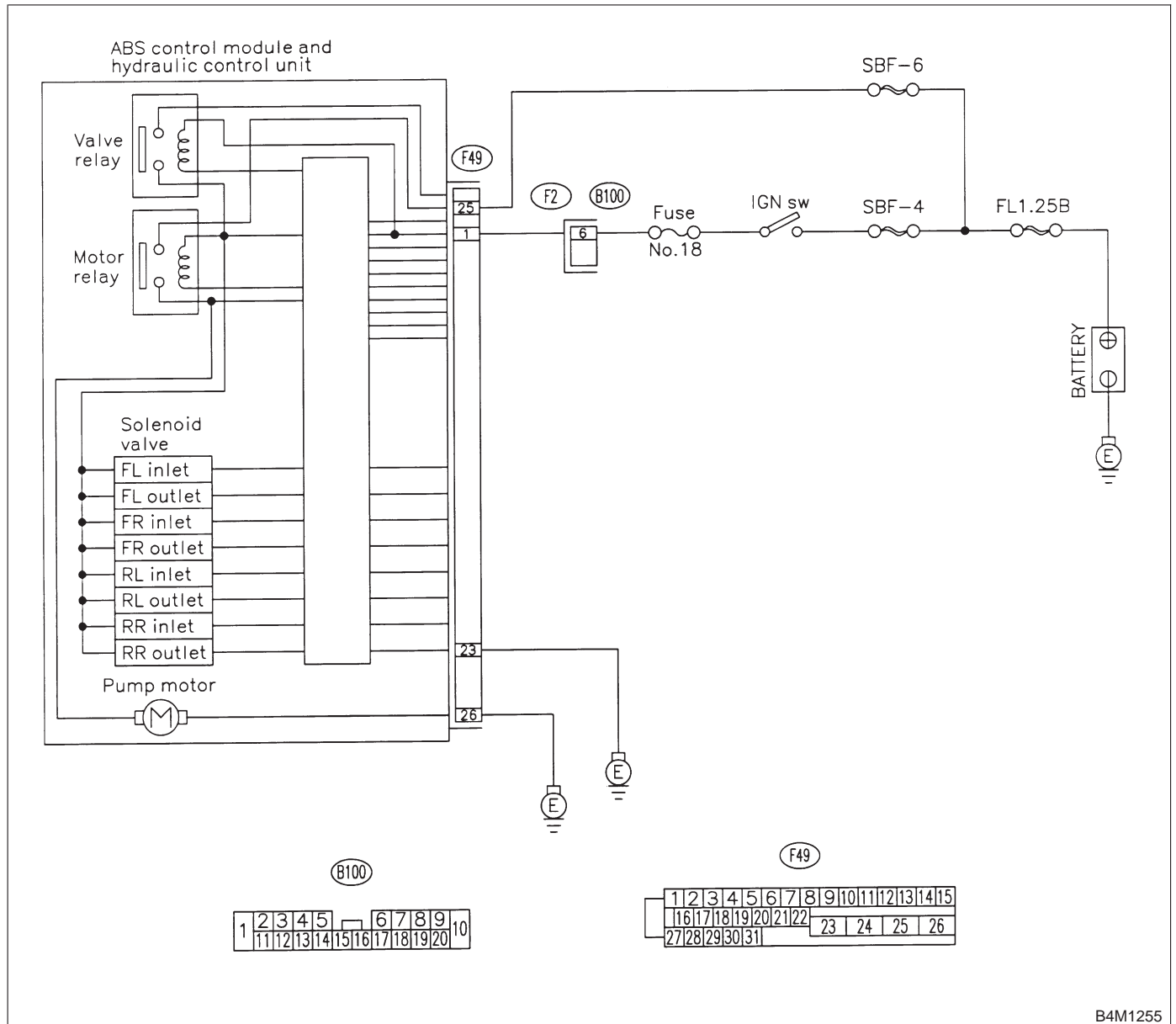

B4M1255

10AC1 : CHECK INPUT VOLTAGE OF ABSCM&H/U.

- 1) Turn ignition switch to OFF.
- 2) Disconnect connector from ABSCM&H/U.
- 3) Turn ignition switch to ON.
- 4) Measure voltage between ABSCM&H/U connector and chassis ground.

Connector & terminal
(F49) No. 25 (+) — Chassis ground (-):

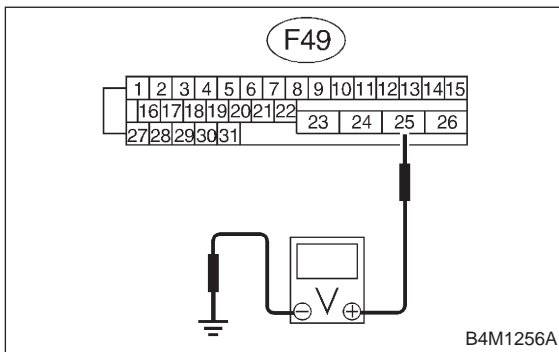

- CHECK** : **Is the voltage between 10 V and 13 V?**
- YES** : Go to step **10AC2**.
- NO** : Repair harness/connector between battery and ABSCM&H/U and check fuse SBF6.

10AC2 : CHECK GROUND CIRCUIT OF MOTOR.

- 1) Turn ignition switch to OFF.
- 2) Measure resistance between ABSCM&H/U connector and chassis ground.

Connector & terminal
(F49) No. 26 — Chassis ground:

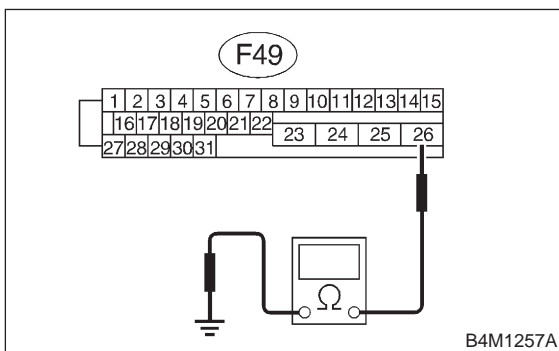

- CHECK** : **Is the resistance less than 0.5 Ω?**
- YES** : Go to step **10AC3**.
- NO** : Repair ABSCM&H/U ground harness.

10AC3 : CHECK MOTOR OPERATION.

Operate the sequence control. <Ref. to 4-4 [W15D1].>

NOTE:

Use the diagnosis connector to operate the sequence control.

- CHECK** : **Can motor revolution noise (buzz) be heard when carrying out the check sequence?**
- YES** : Go to step **10AC4**.
- NO** : Replace ABSCM&H/U.

10AC4 : CHECK POOR CONTACT IN CONNECTORS.

Turn ignition switch to OFF.

- CHECK** : **Is there poor contact in connector between hydraulic unit, relay box and ABSCM&H/U? <Ref. to FOREWORD [T3C1].>**
- YES** : Repair connector.
- NO** : Go to step **10AC5**.

10AC5 : CHECK ABSCM&H/U.

- 1) Connect all connectors.
- 2) Erase the memory.
- 3) Perform inspection mode.
- 4) Read out the trouble code.

- CHECK** : **Is the same trouble code as in the current diagnosis still being output?**
- YES** : Replace ABSCM&H/U.
- NO** : Go to step **10AC6**.

10AC6 : CHECK ANY OTHER TROUBLE CODES APPEARANCE.

- CHECK** : **Are other trouble codes being output?**
- YES** : Proceed with the diagnosis corresponding to the trouble code.
- NO** : A temporary poor contact.

AD: TROUBLE CODE 52 MOTOR RELAY ON FAILURE

— MOTOR RELAY ON FAILURE —

DIAGNOSIS:

- Faulty motor
- Faulty motor relay
- Faulty harness connector

TROUBLE SYMPTOM:

- ABS does not operate.

WIRING DIAGRAM:

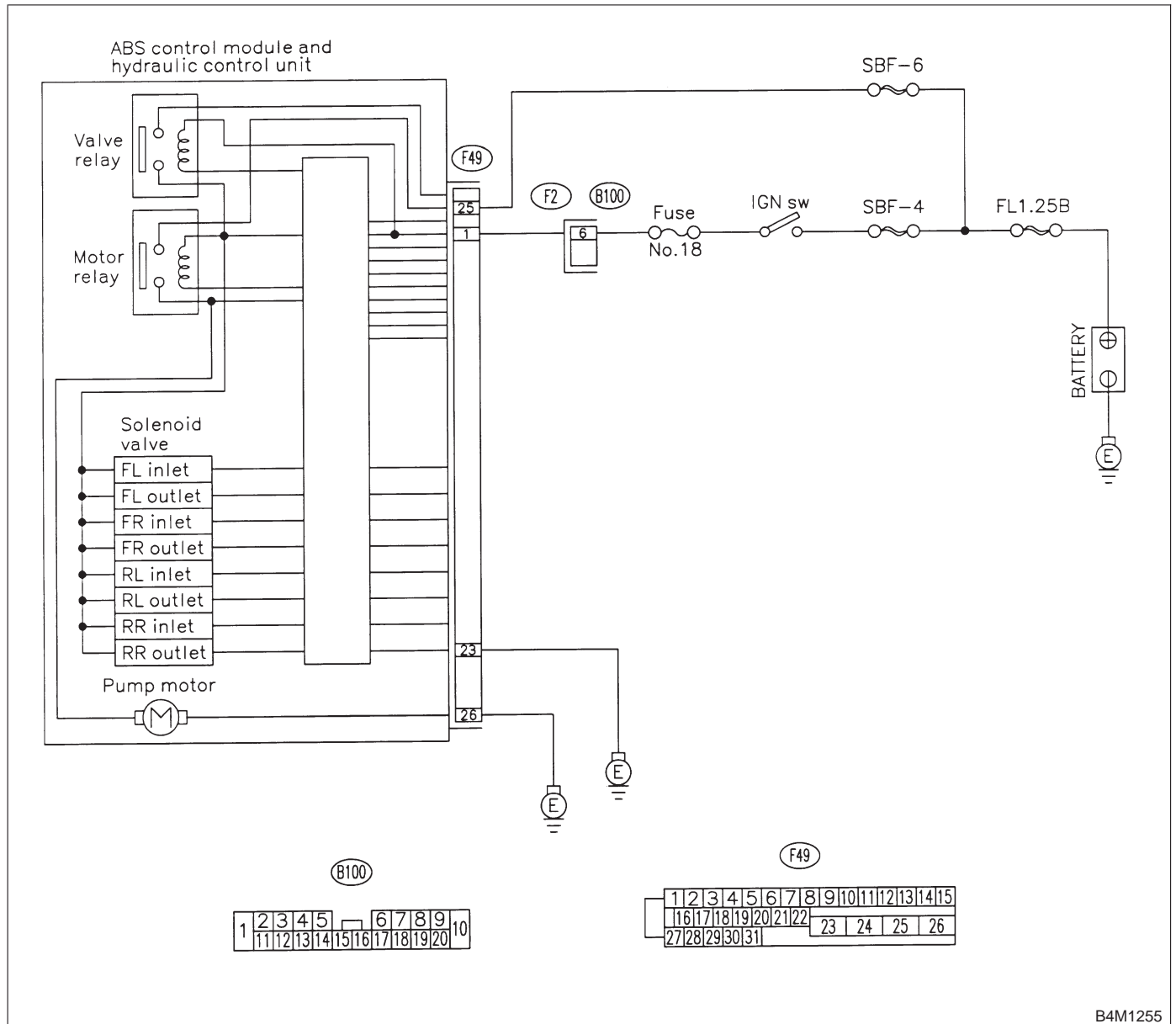

B4M1255

10AD1 : CHECK MOTOR RELAY IN ABSCM&H/U.

Measure resistance between ABSCM&H/U terminals.

Terminals

No. 25 — No. 26:

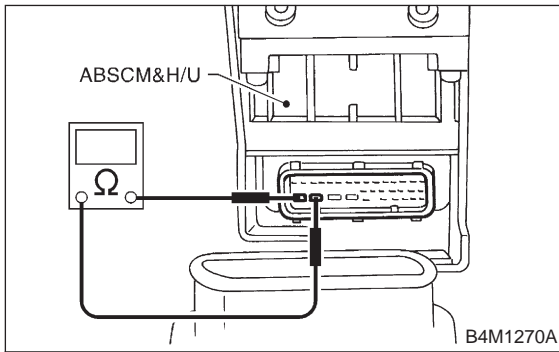

- CHECK** : *Is the resistance more than 1 MΩ?*
- YES** : Go to step 10AD2.
- NO** : Replace ABSCM&H/U.

10AD2 : CHECK MOTOR OPERATION.

Operate the sequence control. <Ref. to 4-4 [W15D1].>

NOTE:

Use the diagnosis connector to operate the sequence control.

- CHECK** : *Can motor revolution noise (buzz) be heard when carrying out the sequence control?*
- YES** : Go to step 10AD3.
- NO** : Replace ABSCM&H/U.

10AD3 : CHECK POOR CONTACT IN CONNECTORS.

Turn ignition switch to OFF.

- CHECK** : *Is there poor contact in connector between hydraulic unit, relay box and ABSCM&H/U? <Ref. to FOREWORD [T3C1].>*
- YES** : Repair connector.
- NO** : Go to step 10AD4.

10AD4 : CHECK ABSCM&H/U.

- 1) Connect all connectors.
- 2) Erase the memory.
- 3) Perform inspection mode.
- 4) Read out the trouble code.

- CHECK** : *Is the same trouble code as in the current diagnosis still being output?*
- YES** : Replace ABSCM&H/U.
- NO** : Go to step 10AD5.

10AD5 : CHECK ANY OTHER TROUBLE CODES APPEARANCE.

- CHECK** : *Are other trouble codes being output?*
- YES** : Proceed with the diagnosis corresponding to the trouble code.
- NO** : A temporary poor contact.

AE: TROUBLE CODE 52 MOTOR MALFUNCTION

— MOTOR MALFUNCTION —

DIAGNOSIS:

- Faulty motor
- Faulty motor relay
- Faulty harness connector

TROUBLE SYMPTOM:

- ABS does not operate.

WIRING DIAGRAM:

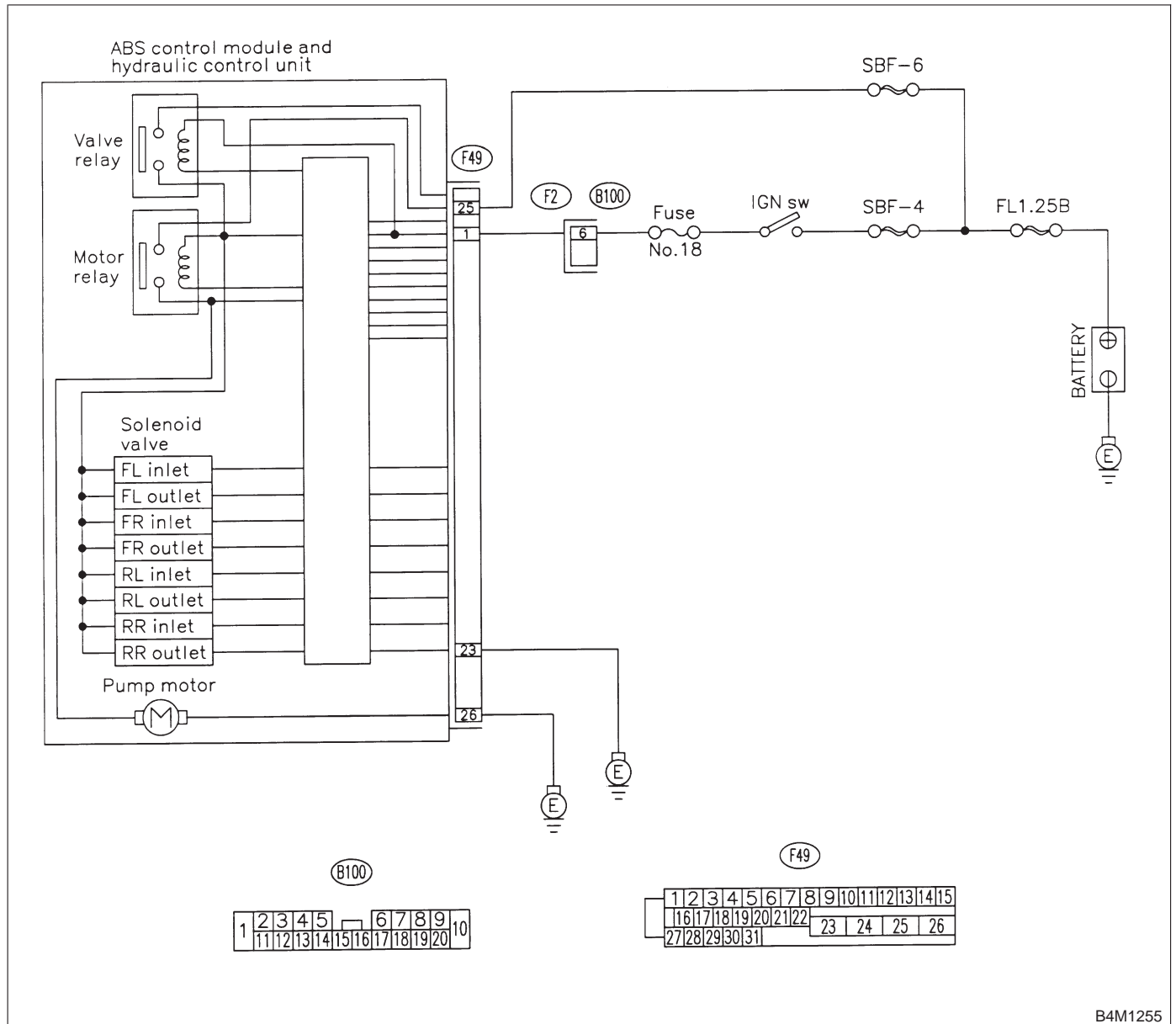

B4M1255

10AE1 : CHECK INPUT VOLTAGE OF ABSCM&H/U.

- 1) Turn ignition switch to OFF.
- 2) Disconnect connector from ABSCM&H/U.
- 3) Turn ignition switch to ON.
- 4) Measure voltage between ABSCM&H/U connector and chassis ground.

Connector & terminal
(F49) No. 25 (+) — Chassis ground (-):

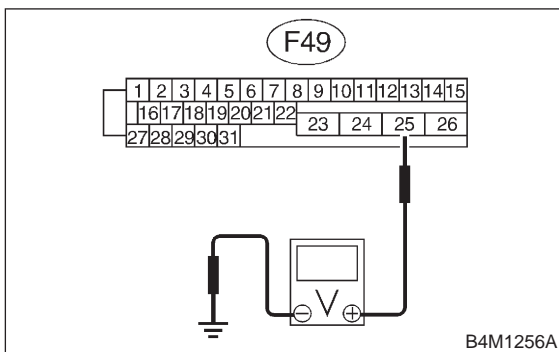

- CHECK** : Is the voltage between 10 V and 13 V?
YES : Go to step 10AE2.
NO : Repair harness/connector between battery and ABSCM&H/U and check fuse SBF6.

10AE2 : CHECK GROUND CIRCUIT OF MOTOR.

- 1) Turn ignition switch to OFF.
- 2) Measure resistance between ABSCM&H/U connector and chassis ground.

Connector & terminal
(F49) No. 26 — Chassis ground:

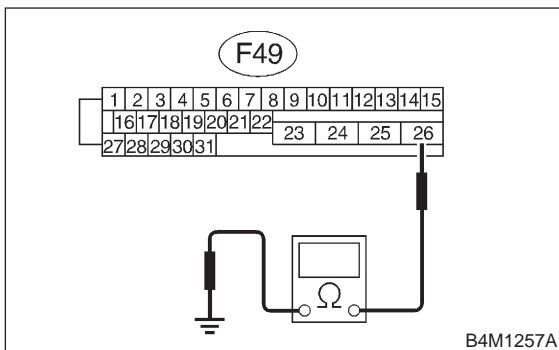

- CHECK** : Is the resistance less than 0.5 Ω?
YES : Go to step 10AE3.
NO : Repair ABSCM&H/U ground harness.

10AE3 : CHECK INPUT VOLTAGE OF ABSCM&H/U.

- 1) Run the engine at idle.
- 2) Measure voltage between ABSCM&H/U connector and chassis ground.

Connector & terminal
(F49) No. 1 (+) — Chassis ground (-):

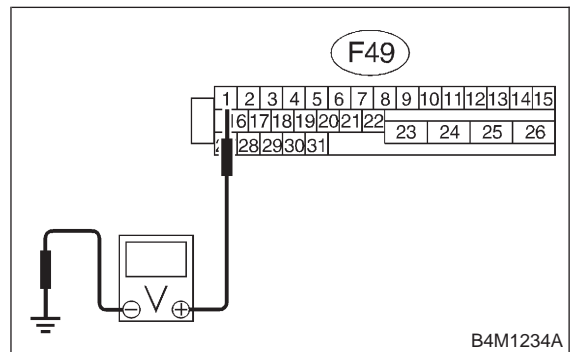

- CHECK** : Is the voltage between 10 V and 15 V?
YES : Go to step 10AE4.
NO : Repair harness connector between battery, ignition switch and ABSCM&H/U.

10AE4 : CHECK GROUND CIRCUIT OF ABSCM&H/U.

- 1) Turn ignition switch to OFF.
- 2) Measure resistance between ABSCM&H/U connector and chassis ground.

Connector & terminal
(F49) No. 23 — Chassis ground:

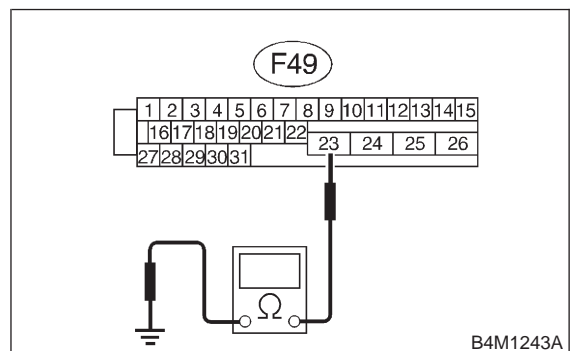

- CHECK** : Is the resistance less than 0.5 Ω?
YES : Go to step 10AE5.
NO : Repair ABSCM&H/U ground harness.

10AE5 : CHECK MOTOR OPERATION.

Operate the sequence control. <Ref. to 4-4 [W15D1].>

NOTE:

Use the diagnosis connector to operate the sequence control.

CHECK : *Can motor revolution noise (buzz) be heard when carrying out the sequence control?*

YES : Go to step 10AE6.

NO : Replace hydraulic unit.

10AE6 : CHECK POOR CONTACT IN CONNECTORS.

Turn ignition switch to OFF.

CHECK : *Is there poor contact in connector between generator, battery and ABSCM&H/U? <Ref. to FOREWORD [T3C1].>*

YES : Repair connector.

NO : Go to step 10AE7.

10AE7 : CHECK ABSCM&H/U.

- 1) Connect all connectors.
- 2) Erase the memory.
- 3) Perform inspection mode.
- 4) Read out the trouble code.

CHECK : *Is the same trouble code as in the current diagnosis still being output?*

YES : Replace ABSCM&H/U.

NO : Go to step 10AE8.

10AE8 : CHECK ANY OTHER TROUBLE CODES APPEARANCE.

CHECK : *Are other trouble codes being output?*

YES : Proceed with the diagnosis corresponding to the trouble code.

NO : A temporary poor contact.

BRAKES

[T10AE8] 4-4

10. Diagnostics Chart with Select Monitor

MEMO:

AF: TROUBLE CODE 54 STOP LIGHT SWITCH SIGNAL CIRCUIT MALFUNCTION

— STOP LIGHT SWITCH SIGNAL CIRCUIT MALFUNCTION —

DIAGNOSIS:

- Faulty stop light switch

TROUBLE SYMPTOM:

- ABS does not operate.

WIRING DIAGRAM:

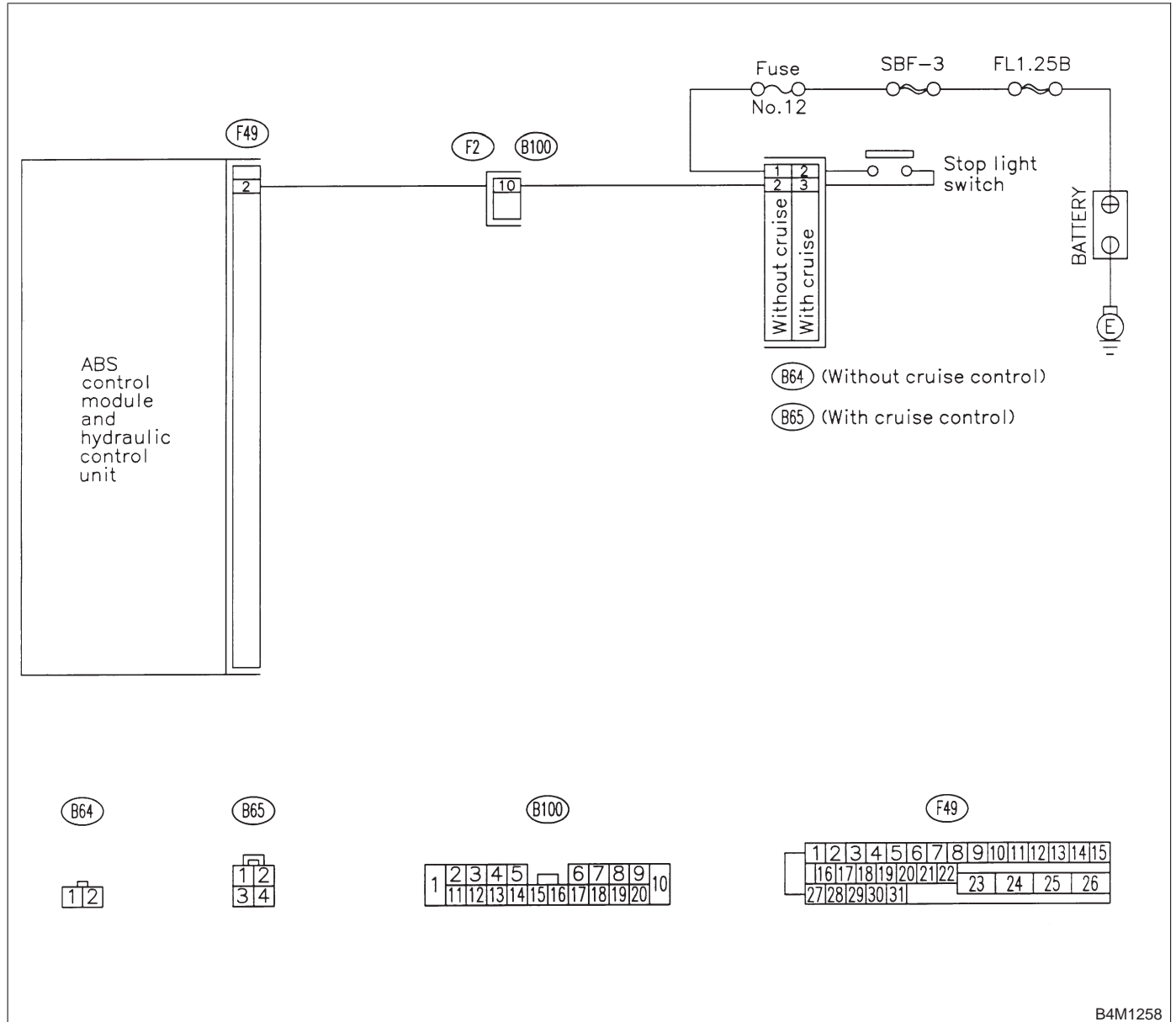

B4M1258

10AF1 : CHECK OUTPUT OF STOP LIGHT SWITCH USING SELECT MONITOR.

- 1) Select "Current data display & Save" on the select monitor.
- 2) Release the brake pedal.
- 3) Read the stop light switch output in the select monitor data display.

- CHECK** : *Is the reading indicated on monitor display less than 1.5 V?*
- YES** : Go to step 10AF2.
- NO** : Go to step 10AF3.

10AF2 : CHECK OUTPUT OF STOP LIGHT SWITCH USING SELECT MONITOR.

- 1) Depress the brake pedal.
- 2) Read the stop light switch output in the select monitor data display.

- CHECK** : *Is the reading indicated on monitor display between 10 V and 15 V?*
- YES** : Go to step 10AF5.
- NO** : Go to step 10AF3.

10AF3 : CHECK IF STOP LIGHTS COME ON.

Depress the brake pedal.

- CHECK** : *Do stop lights turn on?*
- YES** : Go to step 10AF4.
- NO** : Repair stop lights circuit.

10AF4 : CHECK OPEN CIRCUIT IN HARNESS.

- 1) Turn ignition switch to OFF.
- 2) Disconnect connector from ABSCM&H/U.
- 3) Depress brake pedal.
- 4) Measure voltage between ABSCM&H/U connector and chassis ground.

Connector & terminal (F49) No. 2 — Chassis ground:

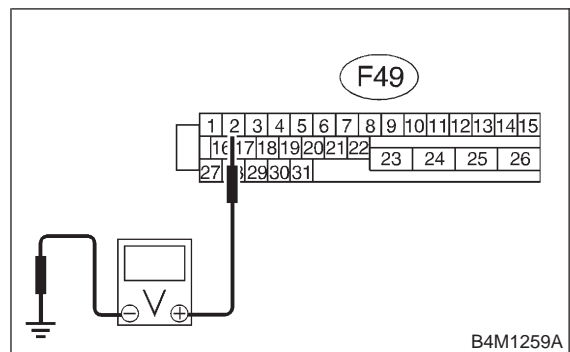

- CHECK** : *Is the voltage between 10 V and 15 V?*
- YES** : Go to step 10AF5.
- NO** : Repair harness between stop light switch and ABSCM&H/U connector.

10AF5 : CHECK POOR CONTACT IN CONNECTORS.

- CHECK** : *Is there poor contact in connector between stop light switch and ABSCM&H/U? <Ref. to FOREWORD [T3C1].>*
- YES** : Repair connector.
- NO** : Go to step 10AF6.

10AF6 : CHECK ABSCM&H/U.

- 1) Connect all connectors.
- 2) Erase the memory.
- 3) Perform inspection mode.
- 4) Read out the trouble code.

- CHECK** : *Is the same trouble code as in the current diagnosis still being output?*
- YES** : Replace ABSCM&H/U.
- NO** : Go to step 10AF7.

10AF7 : CHECK ANY OTHER TROUBLE CODES APPEARANCE.

- CHECK** : *Are other trouble codes being output?*
- YES** : Proceed with the diagnosis corresponding to the trouble code.
- NO** : A temporary poor contact.

BRAKES

[T10AF7] 4-4

10. Diagnostics Chart with Select Monitor

MEMO:

AG: TROUBLE CODE 56 OPEN OR SHORT CIRCUIT IN G SENSOR CIRCUIT

— OPEN OR SHORT CIRCUIT IN G SENSOR CIRCUIT —

DIAGNOSIS:

- Faulty G sensor output voltage

TROUBLE SYMPTOM:

- ABS does not operate.

WIRING DIAGRAM:

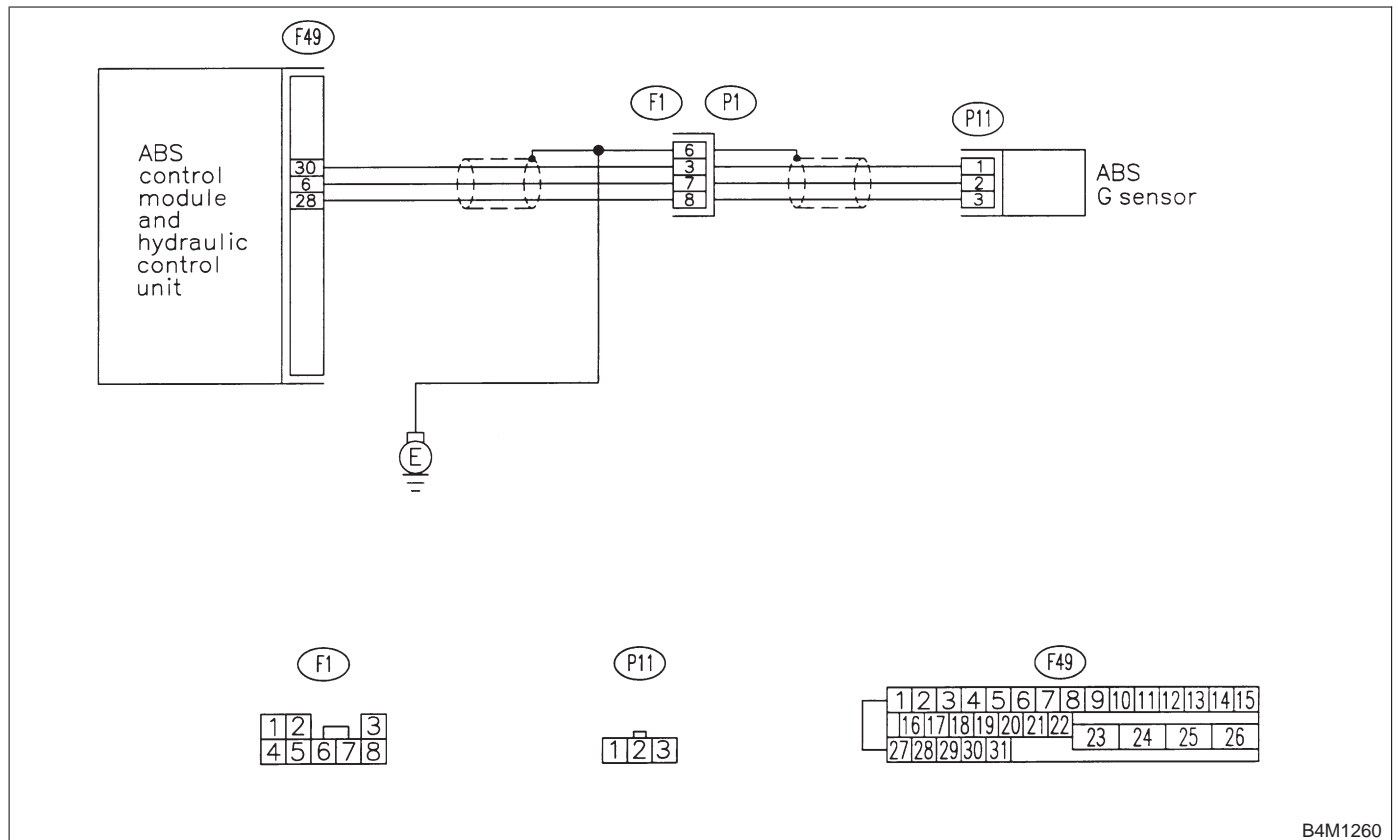

B4M1260

10AG1 : CHECK SPECIFICATIONS OF ABSCM&H/U.

Check specifications of the mark to the ABSCM&H/U.

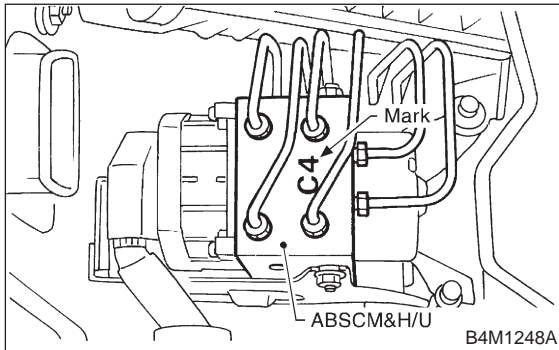

Mark	Model
C5	AWD AT
C6	AWD MT

CHECK : *Is an ABSCM for AWD model installed on a FWD model?*

YES : Replace ABSCM&H/U. <Ref. to 4-4 [W15A0].>

CAUTION:
Be sure to turn ignition switch to OFF when removing ABSCM&H/U.

NO : Go to step 10AG2.

10AG2 : CHECK OUTPUT OF G SENSOR USING SELECT MONITOR.

- 1) Select "Current data display & Save" on the select monitor.
- 2) Read the G sensor output in select monitor data display.

CHECK : *Is the G sensor output on the monitor display between 2.1 and 2.5 V when the G sensor is in horizontal position?*

YES : Go to step 10AG3.

NO : Go to step 10AG6.

10AG3 : CHECK POOR CONTACT IN CONNECTORS.

CHECK : *Is there poor contact in connector between ABSCM&H/U and G sensor? <Ref. to FOREWORD [T3C1].>*

YES : Repair connector.

NO : Go to step 10AG4.

10AG4 : CHECK ABSCM&H/U.

- 1) Connect all connectors.
- 2) Erase the memory.
- 3) Perform inspection mode.
- 4) Read out the trouble code.

CHECK : *Is the same trouble code as in the current diagnosis still being output?*

YES : Replace ABSCM&H/U. <Ref. to 4-4 [W15A0].>

NO : Go to step 10AG5.

10AG5 : CHECK ANY OTHER TROUBLE CODES APPEARANCE.

CHECK : *Are other trouble codes being output?*

YES : Proceed with the diagnosis corresponding to the trouble code.

NO : A temporary poor contact.

10AG6 : CHECK FREEZE FRAME DATA.

- 1) Select "Freeze frame data" on the select monitor.
- 2) Read front right wheel speed on the select monitor display.

CHECK : *Is the front right wheel speed on monitor display 0 km?*

YES : Go to step 10AG7.

NO : Go to step 10AG15.

10AG7 : CHECK FREEZE FRAME DATA.

Read front left wheel speed on the select monitor display.

CHECK : *Is the front left wheel speed on monitor display 0 km?*

YES : Go to step 10AG8.

NO : Go to step 10AG15.

10AG8 : CHECK FREEZE FRAME DATA.

Read rear right wheel speed on the select monitor display.

CHECK : *Is the rear right wheel speed on monitor display 0 km?*

YES : Go to step 10AG9.

NO : Go to step 10AG15.

4-4 [T10AG9]

10. Diagnostics Chart with Select Monitor

BRAKES

10AG9 : CHECK FREEZE FRAME DATA.

Read rear left wheel speed on the select monitor display.

- CHECK** : *Is the rear left wheel speed on monitor display 0 km?*
- YES** : Go to step **10AG10**.
- NO** : Go to step **10AG15**.

10AG10 : CHECK FREEZE FRAME DATA.

Read G sensor output on the select monitor display.

- CHECK** : *Is the G sensor output on monitor display more than 3.65 V?*
- YES** : Go to step **10AG11**.
- NO** : Go to step **10AG15**.

10AG11 : CHECK OPEN CIRCUIT IN G SENSOR OUTPUT HARNESS AND GROUND HARNESS.

- 1) Turn ignition switch to OFF.
- 2) Disconnect connector from ABSCM&H/U.
- 3) Measure resistance between ABSCM&H/U connector terminals.

Connector & terminal

(F49) No. 30 — No. 28:

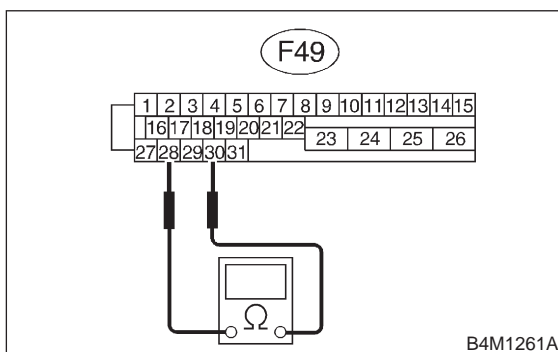

- CHECK** : *Is the resistance between 4.3 and 4.9 k Ω ?*
- YES** : Go to step **10AG12**.
- NO** : Repair harness/connector between G sensor and ABSCM&H/U.

10AG12 : CHECK POOR CONTACT IN CONNECTORS.

- CHECK** : *Is there poor contact in connector between ABSCM&H/U and G sensor? <Ref. to FOREWORD [T3C1].>*
- YES** : Repair connector.
- NO** : Go to step **10AG13**.

10AG13 : CHECK ABSCM&H/U.

- 1) Connect all connectors.
- 2) Erase the memory.
- 3) Perform inspection mode.
- 4) Read out the trouble code.

- CHECK** : *Is the same trouble code as in the current diagnosis still being output?*
- YES** : Replace ABSCM&H/U. <Ref. to 4-4 [W15A0].>
- NO** : Go to step **10AG14**.

10AG14 : CHECK ANY OTHER TROUBLE CODES APPEARANCE.

- CHECK** : *Are other trouble codes being output?*
- YES** : Proceed with the diagnosis corresponding to the trouble code.
- NO** : A temporary poor contact.

10AG15 : CHECK INPUT VOLTAGE OF G SENSOR.

- 1) Turn ignition switch to OFF.
- 2) Remove console box.
- 3) Disconnect G sensor from body. (Do not disconnect connector.)
- 4) Turn ignition switch to ON.
- 5) Measure voltage between G sensor connector terminals.

Connector & terminal
(P11) No. 1 (+) — No. 3 (-):

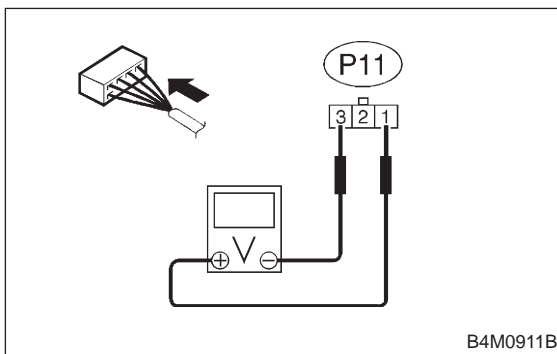

- CHECK** : Is the voltage between 4.75 and 5.25 V?
- YES** : Go to step **10AG16**.
- NO** : Repair harness/connector between G sensor and ABSCM&H/U.

10AG16 : CHECK OPEN CIRCUIT IN G SENSOR OUTPUT HARNESS AND GROUND HARNESS.

- 1) Turn ignition switch to OFF.
- 2) Disconnect connector from ABSCM&H/U.
- 3) Measure resistance between ABSCM&H/U connector terminals.

Connector & terminal
(F49) No. 30 — No. 28:

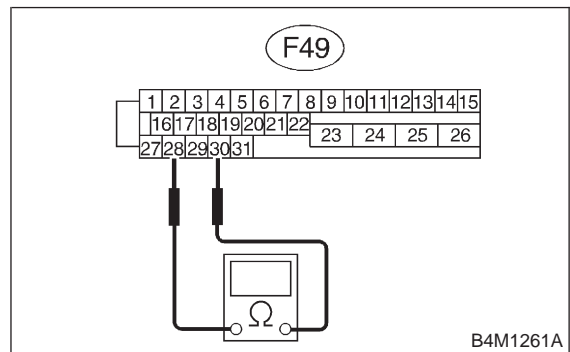

- CHECK** : Is the resistance between 4.3 and 4.9 kΩ?
- YES** : Go to step **10AG17**.
- NO** : Repair harness/connector between G sensor and ABSCM&H/U.

10AG17 : CHECK GROUND SHORT IN G SENSOR OUTPUT HARNESS.

- 1) Disconnect connector from G sensor.
- 2) Measure resistance between ABSCM&H/U connector and chassis ground.

Connector & terminal
(F49) No. 6 — Chassis ground:

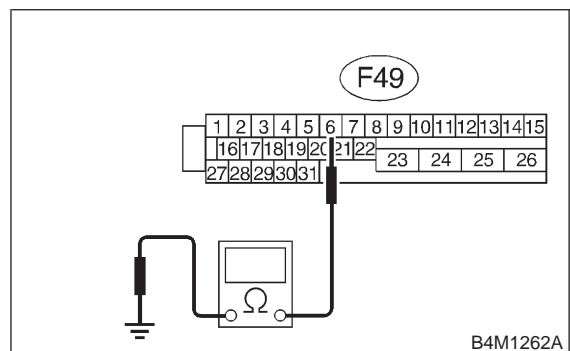

- CHECK** : Is the resistance more than 1 MΩ?
- YES** : Go to step **10AG18**.
- NO** : Repair harness between G sensor and ABSCM&H/U.

10AG18 : CHECK G SENSOR.

- 1) Connect connector to G sensor.
- 2) Connect connector to ABSCM&H/U.
- 3) Turn ignition switch to ON.
- 4) Measure voltage between G sensor connector terminals.

Connector & terminal

(P11) No. 2 (+) — No. 3 (-):

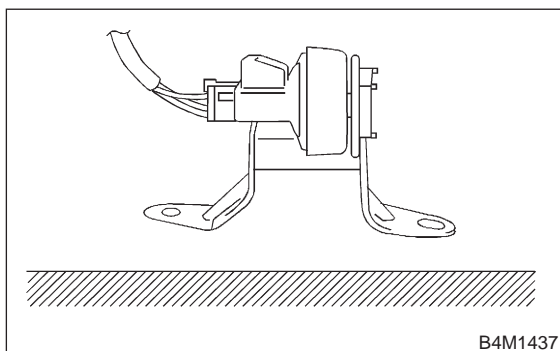
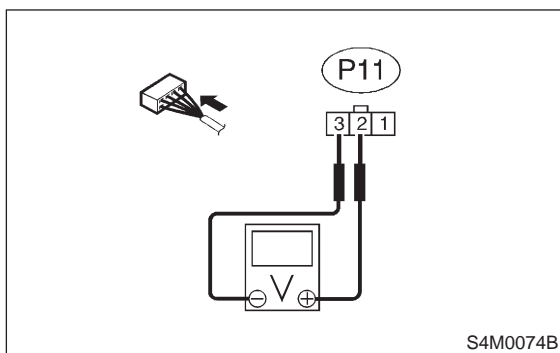

CHECK : *Is the voltage between 2.1 and 2.5 V when G sensor is horizontal?*

YES : Go to step **10AG19**.

NO : Replace G sensor. <Ref. to 4-4 [W16A0].>

10AG19 : CHECK G SENSOR.

Measure voltage between G sensor connector terminals.

Connector & terminal

(P11) No. 2 (+) — No. 3 (-):

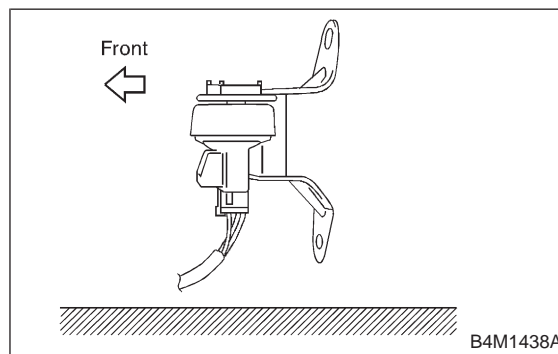

CHECK : *Is the voltage between 3.7 and 4.1 V when G sensor is inclined forwards to 90°?*

YES : Go to step **10AG20**.

NO : Replace G sensor. <Ref. to 4-4 [W16A0].>

10AG20 : CHECK G SENSOR.

Measure voltage between G sensor connector terminals.

Connector & terminal

(P11) No. 2 (+) — No. 3 (-):

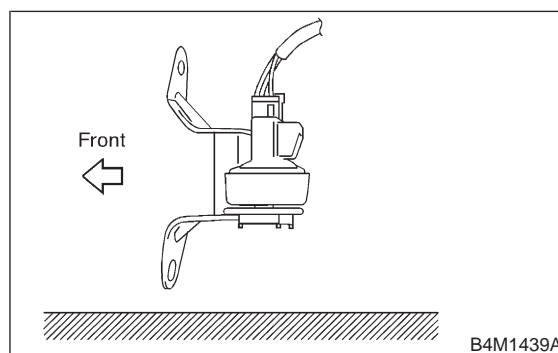

CHECK : *Is the voltage between 0.5 and 0.9 V when G sensor is inclined backwards to 90°?*

YES : Go to step **10AG21**.

NO : Replace G sensor. <Ref. to 4-4 [W16A0].>

10AG21 : CHECK POOR CONTACT IN CONNECTORS.

Turn ignition switch to OFF.

CHECK : *Is there poor contact in connector between ABSCM&H/U and G sensor? <Ref. to FOREWORD [T3C1].>*

YES : Repair connector.

NO : Go to step **10AG22**.

10AG22 : CHECK ABSCM&H/U.

- 1) Connect all connectors.
- 2) Erase the memory.
- 3) Perform inspection mode.
- 4) Read out the trouble code.

CHECK : *Is the same trouble code as in the current diagnosis still being output?*

YES : Replace ABSCM&H/U. <Ref. to 4-4 [W15A0].>

NO : Go to step **10AG23**.

10AG23 : CHECK ANY OTHER TROUBLE CODES APPEARANCE.

CHECK : *Are other trouble codes being output?*

YES : Proceed with the diagnosis corresponding to the trouble code.

NO : A temporary poor contact.

AH: TROUBLE CODE 56 BATTERY SHORT IN G SENSOR CIRCUIT

— BATTERY SHORT IN G SENSOR CIRCUIT —

DIAGNOSIS:

- Faulty G sensor output voltage

TROUBLE SYMPTOM:

- ABS does not operate.

WIRING DIAGRAM:

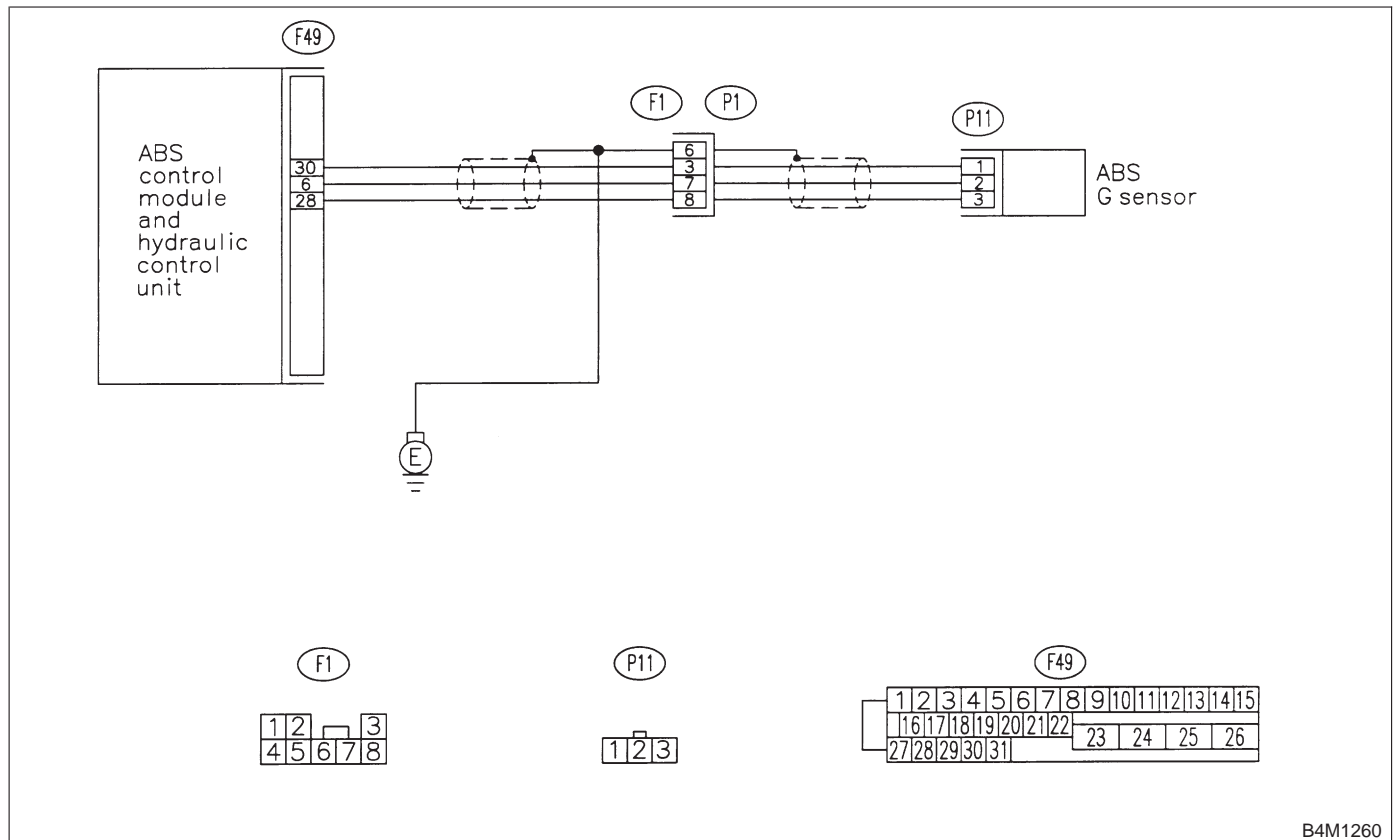

B4M1260

10AH1 : CHECK OUTPUT OF G SENSOR USING SELECT MONITOR.

- 1) Select "Current data display & Save" on the select monitor.
- 2) Read G sensor output on the select monitor display.

CHECK : *Is the G sensor output on monitor display between 2.1 and 2.5 V when the G sensor is in horizontal position?*

YES : Replace ABSCM&H/U.

NO : Go to step 10AH2.

10AH2 : CHECK BATTERY SHORT OF HARNESS.

- 1) Turn ignition switch to OFF.
- 2) Remove console box.
- 3) Disconnect connector from G sensor.
- 4) Disconnect connector from ABSCM&H/U.
- 5) Measure voltage between ABSCM&H/U connector and chassis ground.

Connector & terminal
(F49) No. 6 (+) — Chassis ground (-):

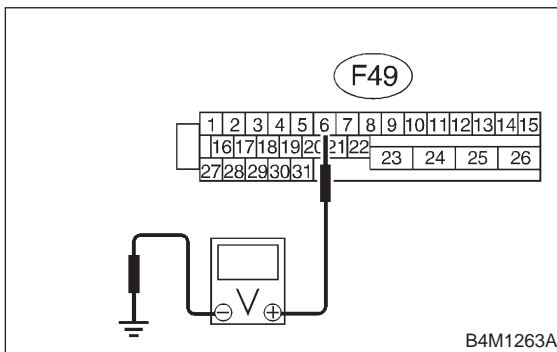

CHECK : *Is the voltage less than 1 V?*

YES : Go to step 10AH3.

NO : Repair harness between G sensor and ABSCM&H/U.

10AH3 : CHECK BATTERY SHORT OF HARNESS.

- 1) Turn ignition switch to ON.
- 2) Measure voltage between ABSCM&H/U connector and chassis ground.

Connector & terminal
(F49) No. 6 (+) — Chassis ground (-):

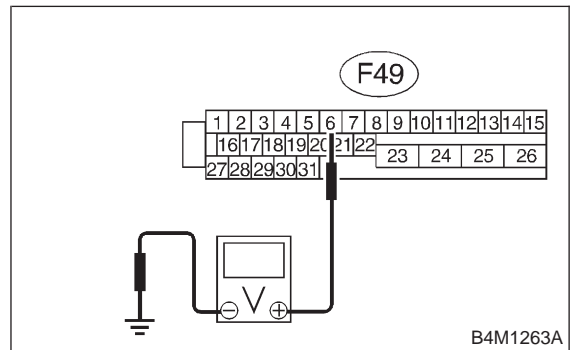

CHECK : *Is the voltage less than 1 V?*

YES : Go to step 10AH4.

NO : Repair harness between G sensor and ABSCM&H/U.

10AH4 : CHECK ABSCM&H/U.

- 1) Turn ignition switch to OFF.
- 2) Connect all connectors.
- 3) Erase the memory.
- 4) Perform inspection mode.
- 5) Read out the trouble code.

CHECK : *Is the same trouble code as in the current diagnosis still being output?*

YES : Replace ABSCM&H/U.

NO : Go to step 10AH5.

10AH5 : CHECK ANY OTHER TROUBLE CODES APPEARANCE.

CHECK : *Are other trouble codes being output?*

YES : Proceed with the diagnosis corresponding to the trouble code.

NO : A temporary poor contact.

AI: TROUBLE CODE 56 ABNORMAL G SENSOR HIGH μ OUTPUT

— ABNORMAL G SENSOR HIGH μ OUTPUT —

DIAGNOSIS:

- Faulty G sensor output voltage

TROUBLE SYMPTOM:

- ABS does not operate.

WIRING DIAGRAM:

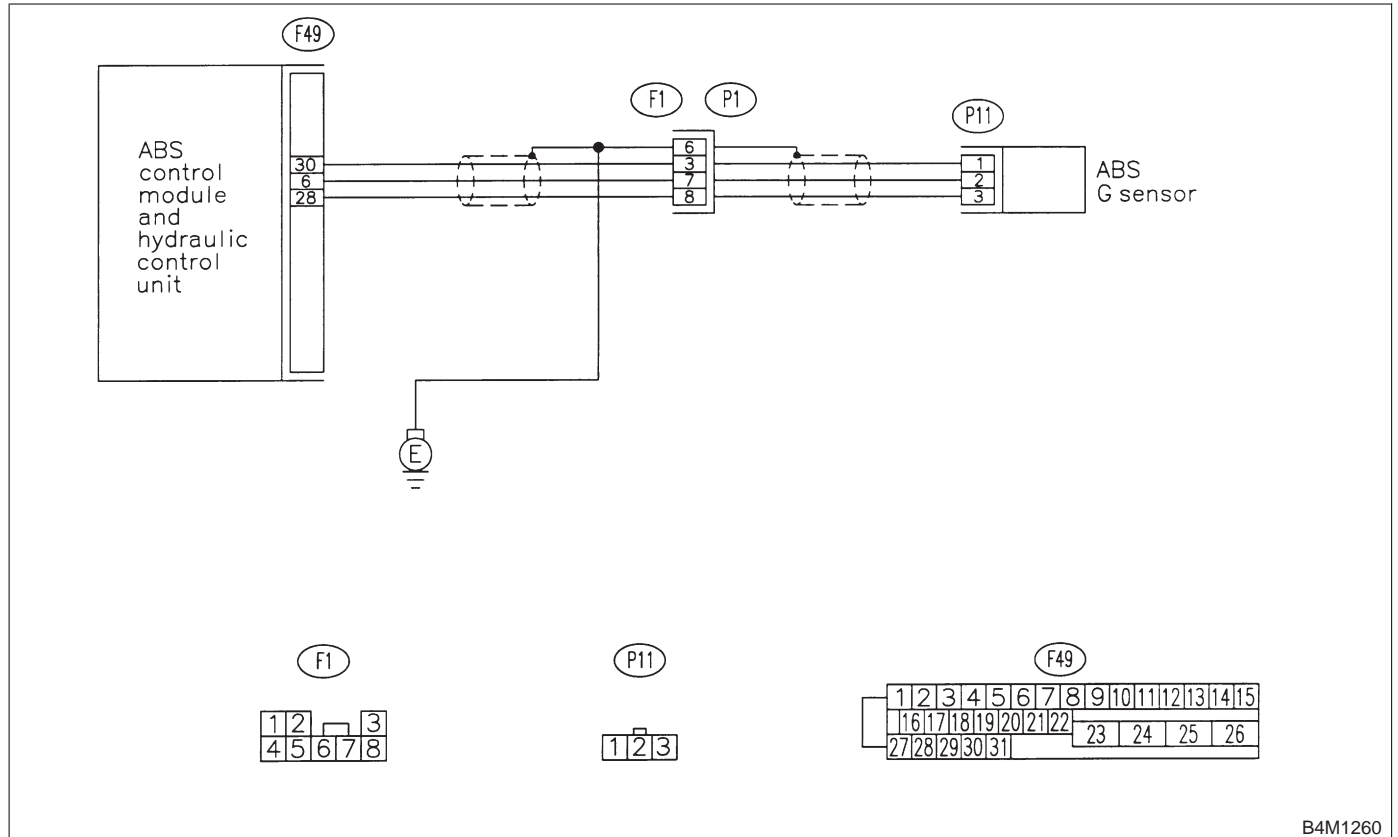

B4M1260

10A11 : CHECK OUTPUT OF G SENSOR USING SELECT MONITOR.

- 1) Select "Current data display & Save" on the select monitor.
- 2) Read G sensor output on the select monitor display.

CHECK : *Is the G sensor output on monitor display 2.3 ± 0.2 V when the G sensor is in horizontal position?*

YES : Go to step 10A12.

NO : Go to step 10A16.

10A12 : CHECK POOR CONTACT IN CONNECTORS.

Turn ignition switch to OFF.

CHECK : *Is there poor contact in connector between ABSCM&H/U and G sensor? <Ref. to FOREWORD [T3C1].>*

YES : Repair connector.

NO : Go to step 10A13.

10A13 : CHECK ABSCM&H/U.

- 1) Connect all connectors.
- 2) Erase the memory.
- 3) Perform inspection mode.
- 4) Read out the trouble code.

CHECK : *Is the same trouble code as in the current diagnosis still being output?*

YES : Replace ABSCM&H/U.

NO : Go to step 10A14.

10A14 : CHECK ANY OTHER TROUBLE CODES APPEARANCE.

CHECK : *Are other trouble codes being output?*

YES : Proceed with the diagnosis corresponding to the trouble code.

NO : A temporary poor contact.

10A15 : CHECK OPEN CIRCUIT IN G SENSOR OUTPUT HARNESS AND GROUND HARNESS.

- 1) Turn ignition switch to OFF.
- 2) Disconnect connector from ABSCM&H/U.
- 3) Measure resistance between ABSCM&H/U connector terminals.

Connector & terminal (F49) No. 30 — No. 28:

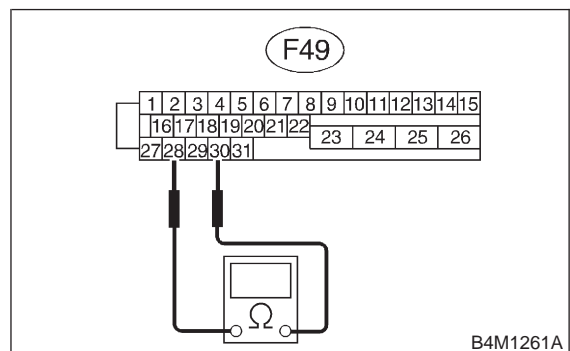

CHECK : *Is the resistance between 4.3 and 4.9 kΩ?*

YES : Go to step 10A16.

NO : Repair harness/connector between G sensor and ABSCM&H/U.

10A16 : CHECK GROUND SHORT OF HARNESS.

Measure resistance between ABSCM&H/U connector and chassis ground.

Connector & terminal (F49) No. 28 — Chassis ground:

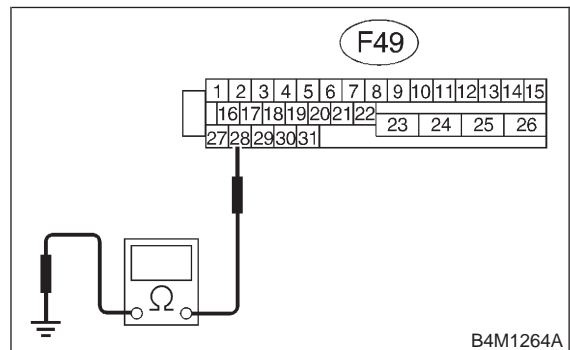

CHECK : *Is the resistance more than 1 MΩ?*

YES : Go to step 10A17.

NO : Repair harness between G sensor and ABSCM&H/U.
Replace ABSCM&H/U.

10A17 : CHECK G SENSOR.

- 1) Remove console box.
- 2) Remove G sensor from vehicle.
- 3) Connect connector to G sensor.
- 4) Connect connector to ABSCM&H/U.
- 5) Turn ignition switch to ON.
- 6) Measure voltage between G sensor connector terminals.

Connector & terminal

(P11) No. 2 (+) — No. 3 (-):

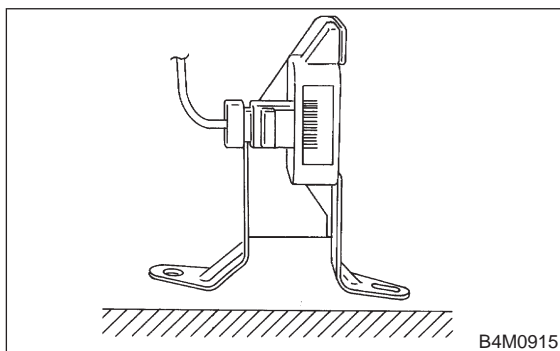
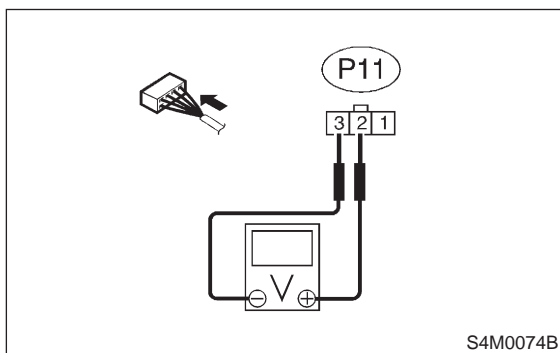

CHECK : *Is the voltage between 2.1 and 2.5 V when G sensor is horizontal?*

YES : Go to step 10A18.

NO : Replace G sensor.

10A18 : CHECK G SENSOR.

Measure voltage between G sensor connector terminals.

Connector & terminal

(P11) No. 2 (+) — No. 3 (-):

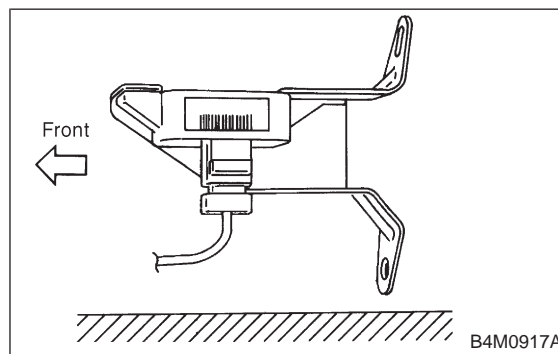

CHECK : *Is the voltage between 3.7 and 4.1 V when G sensor is inclined forwards to 90°?*

YES : Go to step 10A19.

NO : Replace G sensor.

10A19 : CHECK G SENSOR.

Measure voltage between G sensor connector terminals.

Connector & terminal

(P11) No. 2 (+) — No. 3 (-):

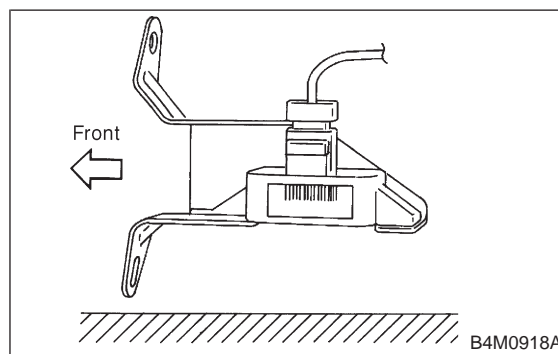

CHECK : *Is the voltage between 0.5 and 0.9 V when G sensor is inclined backwards to 90°?*

YES : Go to step 10A110.

NO : Replace G sensor.

10AI10 : CHECK ABSCM&H/U.

- 1) Turn ignition switch to OFF.
- 2) Connect all connectors.
- 3) Erase the memory.
- 4) Perform inspection mode.
- 5) Read out the trouble code.

CHECK : *Is the same trouble code as in the current diagnosis still being output?*

YES : Replace ABSCM&H/U.

NO : Go to step **10AI11**.

10AI11 : CHECK ANY OTHER TROUBLE CODES APPEARANCE.

CHECK : *Are other trouble codes being output?*

YES : Proceed with the diagnosis corresponding to the trouble code.

NO : A temporary poor contact.

AJ: TROUBLE CODE 56 DETECTION OF G SENSOR STICK

— DETECTION OF G SENSOR STICK —

DIAGNOSIS:

- Faulty G sensor output voltage

TROUBLE SYMPTOM:

- ABS does not operate.

WIRING DIAGRAM:

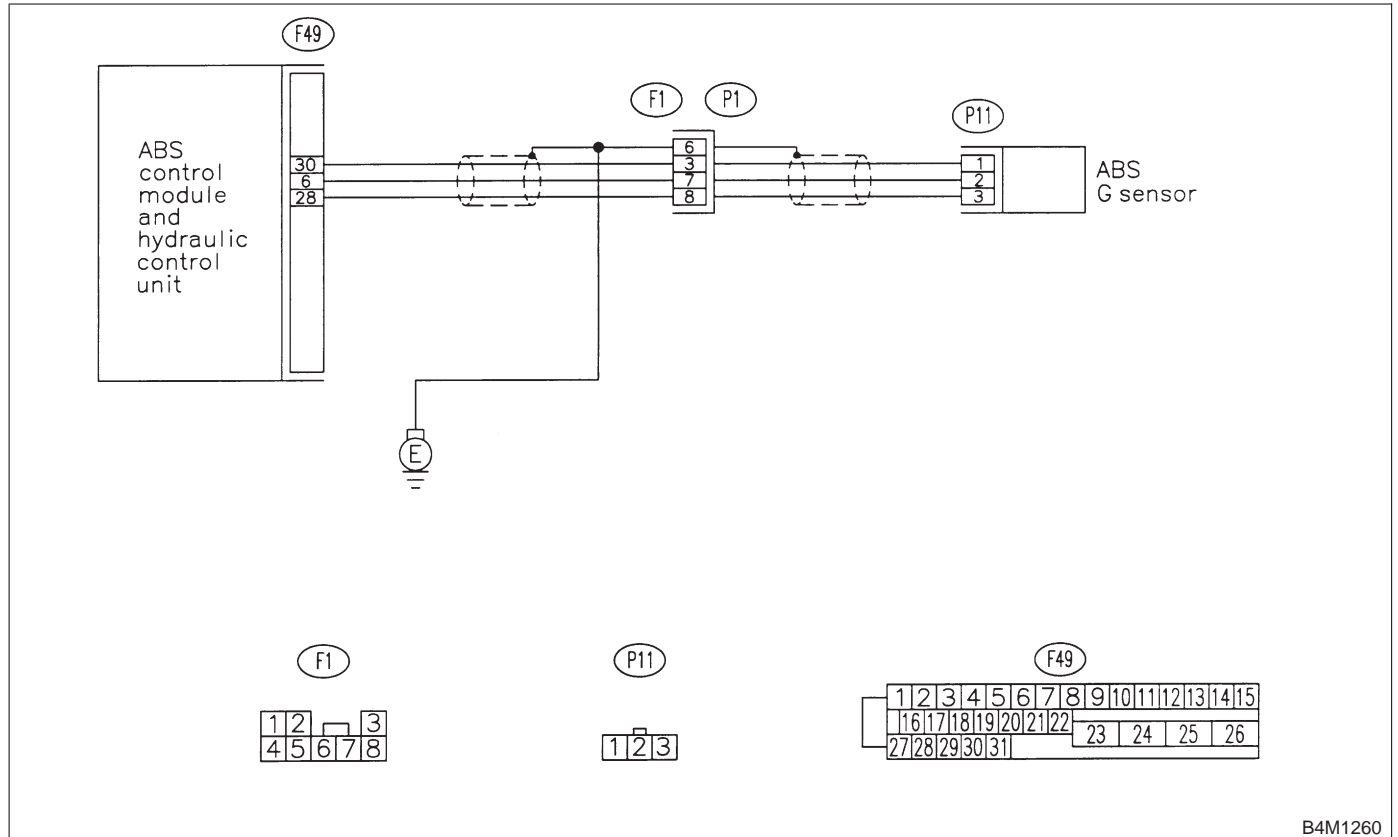

B4M1260

10AJ1 : CHECK ALL FOUR WHEELS FOR FREE TURNING.

- CHECK** : *Have the wheels been turned freely such as when the vehicle is lifted up, or operated on a rolling road?*
- YES** : The ABS is normal. Erase the trouble code.
- NO** : Go to step **10AJ2**.

10AJ2 : CHECK OUTPUT OF G SENSOR USING SELECT MONITOR.

- 1) Select "Current data display & Save" on the select monitor.
- 2) Read the select monitor display.

- CHECK** : *Is the G sensor output on the monitor display between 2.1 and 2.5 V when the vehicle is in horizontal position?*
- YES** : Go to step **10AJ3**.
- NO** : Go to step **10AJ8**.

10AJ3 : CHECK OUTPUT OF G SENSOR USING SELECT MONITOR.

- 1) Turn ignition switch to OFF.
- 2) Remove console box.
- 3) Remove G sensor from vehicle. (Do not disconnect connector.)
- 4) Turn ignition switch to ON.
- 5) Select "Current data display & Save" on the select monitor.
- 6) Read the select monitor display.

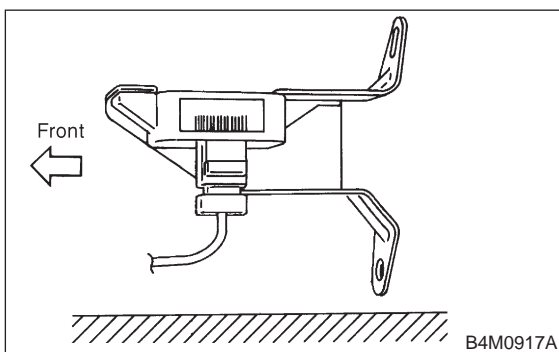

- CHECK** : *Is the G sensor output on the monitor display between 3.7 and 4.1 V when G sensor is inclined forwards to 90°?*
- YES** : Go to step **10AJ4**.
- NO** : Replace G sensor.

10AJ4 : CHECK OUTPUT OF G SENSOR USING SELECT MONITOR.

Read the select monitor display.

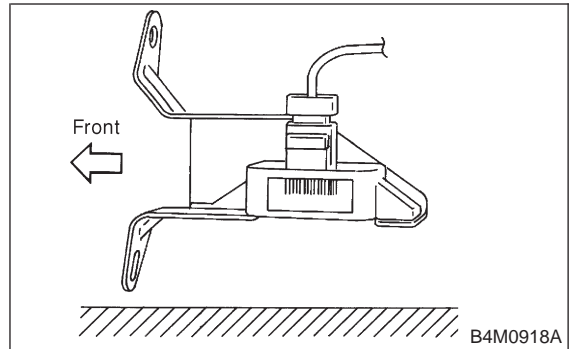

- CHECK** : *Is the G sensor output on the monitor display between 0.5 and 0.9 V when G sensor is inclined backwards to 90°?*
- YES** : Go to step **10AJ5**.
- NO** : Replace G sensor.

10AJ5 : CHECK POOR CONTACT IN CONNECTORS.

Turn ignition switch to OFF.

- CHECK** : *Is there poor contact in connector between ABSCM&H/U and G sensor? <Ref. to FOREWORD [T3C1].>*
- YES** : Repair connector.
- NO** : Go to step **10AJ6**.

10AJ6 : CHECK ABSCM&H/U.

- 1) Connect all connectors.
- 2) Erase the memory.
- 3) Perform inspection mode.
- 4) Read out the trouble code.

- CHECK** : *Is the same trouble code as in the current diagnosis still being output?*
- YES** : Replace ABSCM&H/U.
- NO** : Go to step **10AJ7**.

10AJ7 : CHECK ANY OTHER TROUBLE CODES APPEARANCE.

- CHECK** : *Are other trouble codes being output?*
- YES** : Proceed with the diagnosis corresponding to the trouble code.
- NO** : A temporary poor contact.

4-4 [T10AJ8]

10. Diagnostics Chart with Select Monitor

BRAKES

10AJ8 : CHECK OPEN CIRCUIT IN G SENSOR OUTPUT HARNESS AND GROUND HARNESS.

- 1) Turn ignition switch to OFF.
- 2) Disconnect connector from ABSCM&H/U.
- 3) Measure resistance between ABSCM&H/U connector terminals.

Connector & terminal

(F49) No. 30 — No. 28:

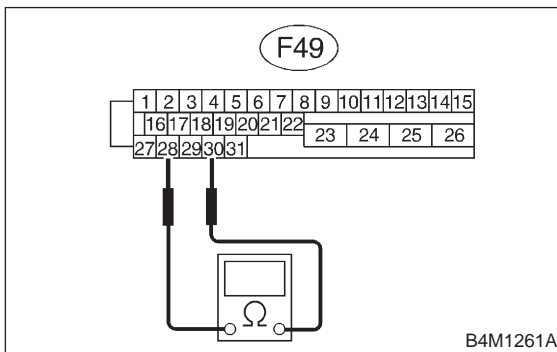

- CHECK** : Is the resistance between 4.3 and 4.9 kΩ?
- YES** : Go to step 10AJ9.
- NO** : Repair harness/connector between G sensor and ABSCM&H/U.

10AJ9 : CHECK G SENSOR.

- 1) Remove console box.
- 2) Remove G sensor from vehicle.
- 3) Connect connector to G sensor.
- 4) Connect connector to ABSCM&H/U.
- 5) Turn ignition switch to ON.
- 6) Measure voltage between G sensor connector terminals.

Connector & terminal

(P11) No. 2 (+) — No. 1 (-):

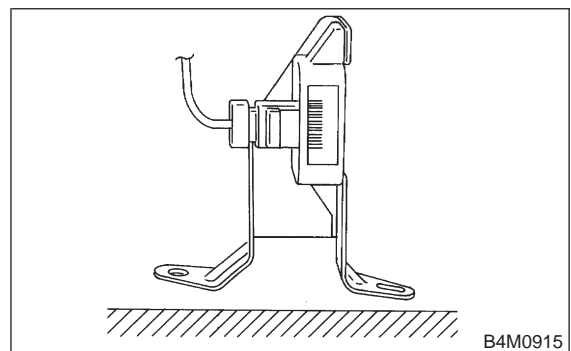
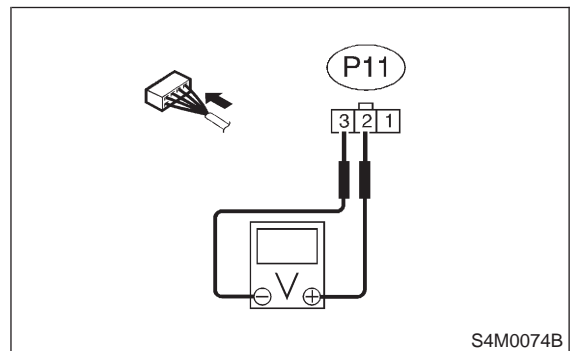

- CHECK** : Is the voltage between 2.1 and 2.5 V when G sensor is horizontal?
- YES** : Go to step 10AJ10.
- NO** : Replace G sensor.

10AJ10 : CHECK G SENSOR.

Measure voltage between G sensor connector terminals.

Connector & terminal

(P11) No. 2 (+) — No. 1 (-):

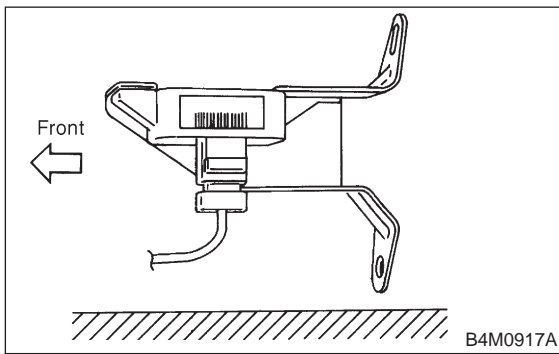

CHECK : *Is the voltage between 3.7 and 4.1 V when G sensor is inclined forwards to 90°?*

YES : Go to step 10AJ11.

NO : Replace G sensor.

10AJ11 : CHECK G SENSOR.

Measure voltage between G sensor connector terminals.

Connector & terminal

(P11) No. 2 (+) — No. 1 (-):

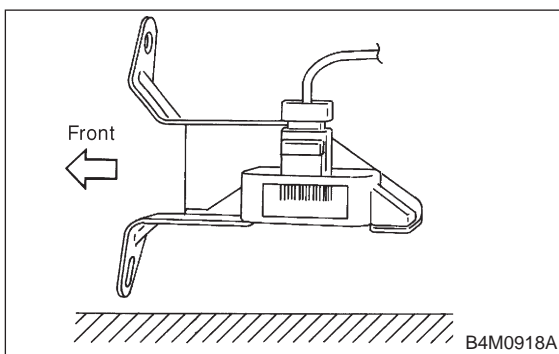

CHECK : *Is the voltage between 0.5 and 0.9 V when G sensor is inclined backwards to 90°?*

YES : Go to step 10AJ12.

NO : Replace G sensor.

10AJ12 : CHECK ABSCM&H/U.

- 1) Turn ignition switch to OFF.
- 2) Connect all connectors.
- 3) Erase the memory.
- 4) Perform inspection mode.
- 5) Read out the trouble code.

CHECK : *Is the same trouble code as in the current diagnosis still being output?*

YES : Replace ABSCM&H/U.

NO : Go to step 10AJ13.

10AJ13 : CHECK ANY OTHER TROUBLE CODES APPEARANCE.

CHECK : *Are other trouble codes being output?*

YES : Proceed with the diagnosis corresponding to the trouble code.

NO : A temporary poor contact.