

## 1. Precaution

### A: SUPPLEMENTAL RESTRAINT SYSTEM "AIRBAG"

Airbag system wiring harness is routed near the keyless entry control module.

**CAUTION:**

- All airbag system wiring harness and connectors are colored yellow. Do not use electrical test equipment on these circuits.
- Be careful not to damage airbag system wiring harness when servicing the keyless entry control module.

## 2. Pre-inspection

### A: POWER DOOR LOCK

**2A1 : CHECK POWER DOOR LOCK.**

Perform lock and unlock with door lock switch.

**CHECK** : *Does the power door lock function normally?*

**YES** : Go to step 2B1.

**NO** : Repair power door lock. <Ref. to 6-2 [W1800].>

### B: TRANSMITTER

**2B1 : CHECK TRANSMITTER BATTERY.**

1) Remove battery from transmitter.

**NOTE:**

To prevent static electricity damage to transmitter printed circuit board, touch steel area of building with hand to discharge static electricity carried on body or clothes before disassembling transmitter.

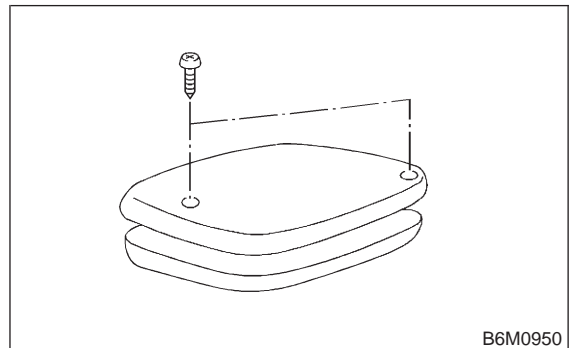

B6M0950

2) Measure voltage battery.

NOTE:

- Battery discharge occurs during measurement. Complete measurement within 5 seconds.
- During battery voltage measurement, voltage falls more than 1.8 volts during 3 seconds period. Weak battery is indicated. Replace battery.

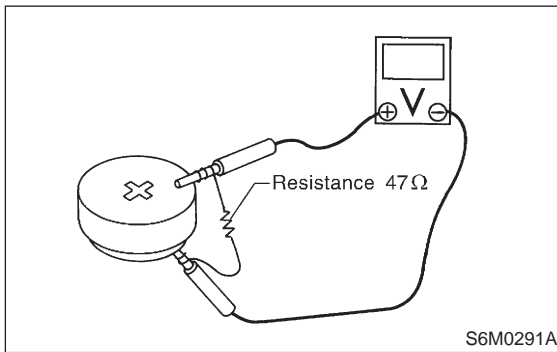

- CHECK** : *Is the voltage more than 2 V?*  
**YES** : Go to step **2B2**.  
**NO** : Replace transmitter battery. (Use CR2032 or equivalent.)

**2B2 : CHECK LED OF TRANSMITTER.**

- 1) Press either the LOCK/ARM or UNLOCK/DISARM button six times to synchronize with the keyless entry control module.
- 2) Press the LOCK/ARM button.

- CHECK** : *Does the LED blink one time?*  
**YES** : Go to step **2B3**.  
**NO** : Replace transmitter.

**2B3 : CHECK LED OF TRANSMITTER.**

Keep the LOCK/ARM button pressed.

- CHECK** : *Does the LED blink one time and then turn on?*  
**YES** : Go to step **2B4**.  
**NO** : Replace transmitter.

**2B4 : CHECK LED OF TRANSMITTER.**

Press the UNLOCK/DISARM button.

- CHECK** : *Does the LED blink one time?*  
**YES** : Go to step **2B5**.  
**NO** : Replace transmitter.

**2B5 : CHECK LED OF TRANSMITTER.**

Keep the UNLOCK/DISARM button pressed.

- CHECK** : *Does the LED blink two times?*  
**YES** : Go to step **2B6**.  
**NO** : Replace transmitter.

**2B6 : CHECK POWER DOOR LOCK FUNCTION.**

Perform lock and unlock function of power door lock with transmitter.

- CHECK** : *Does it function normally?*  
**YES** : Go to step **2B7**.  
**NO** : Replace transmitter.

**2B7 : CHECK ON/OFF SELECT HORN SIGNAL.**

Press the LOCK/ARM or UNLOCK/DISARM button.

- CHECK** : *Does the horn signal chirp?*  
**YES** : Go to step **2B8**.  
**NO** : Keep both LOCK/ARM and UNLOCK/DISARM buttons pressed for more than 1.5 seconds. Go to step **2B8**.

**2B8 : CHECK ON/OFF SELECT HORN SIGNAL.**

Keep both LOCK/ARM and UNLOCK/DISARM buttons pressed for more than 1.5 seconds.

- CHECK** : *Does the horn signal chirp two times?*  
**YES** : Go to step **2B9**.  
**NO** : Replace transmitter.

**2B9 : CHECK ON/OFF SELECT HORN SIGNAL.**

Press LOCK/ARM or UNLOCK/DISARM button.

- CHECK** : *Does the horn signal chirp?*  
**YES** : Replace transmitter.  
**NO** : Go to step **2B10**.

**2B10 : CHECK ON/OFF SELECT HORN SIGNAL.**

Keep both LOCK/ARM and UNLOCK/DISARM buttons pressed for more than 1.5 seconds.

- CHECK** : *Does the horn signal chirp one time?*
- YES** : Go to step 2B11.
- NO** : Replace transmitter.

**2B11 : CHECK ON/OFF SELECT HORN SIGNAL.**

Press LOCK/ARM and UNLOCK/DISARM button.

- CHECK** : *Does the horn signal chirp?*
- YES** : Go to step 2B12.
- NO** : Replace transmitter.

**2B12 : CHECK FOR UNCHECKED TRANSMITTER.**

Check for an unchecked transmitter.

- CHECK** : *Does an unchecked transmitter exist?*
- YES** : Check for an unchecked transmitter. Go to step 2B1.
- NO** : Go to step 2C1.

**C: FUSE**

**2C1 : CHECK FUSE NO. 11.**

Remove and visually check the fuse No. 11 (in fuse box).

- CHECK** : *Is fuse No. 11 blown?*
- YES** : Replace fuse (20 A).
- NO** : Go to step 2D1.

**D: POWER SUPPLY CIRCUIT**

**2D1 : CHECK POWER SUPPLY CIRCUIT.**

Measure voltage between fuse box connector (B52) and chassis ground.

**Connector & terminal**

**(B52) No. 9 (+) — Chassis ground (-):**

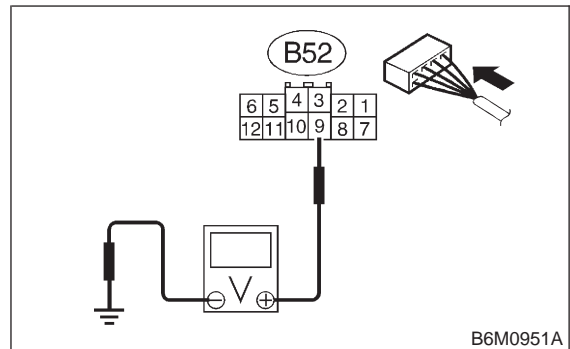

- CHECK** : *Is the voltage more than 10 V?*
- YES** : Go to step 2D2.
- NO** : Repair wiring harness between fuse box and battery.

**2D2 : CHECK POWER SUPPLY CIRCUIT.**

- 1) Disconnect connector from keyless entry control module.
- 2) Measure voltage between keyless entry control module connector (B176) and chassis ground.

**Connector & terminal**

**(B176) No. 3 (+) — Chassis ground (-):**

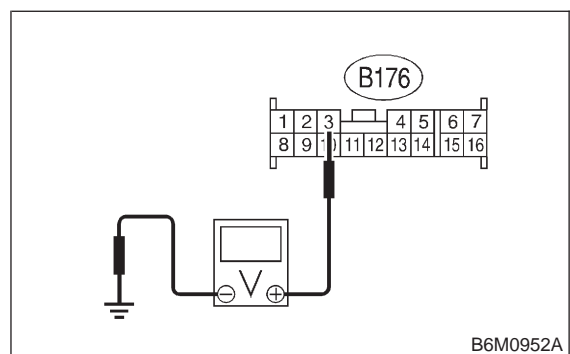

- CHECK** : *Is the voltage more than 10 V?*
- YES** : Go to step 2E1.
- NO** : Repair wiring harness between keyless entry control module and fuse box.

**E: GROUND CIRCUIT**

**2E1 : CHECK GROUND CIRCUIT.**

Measure resistance between keyless entry control module connector (B176) and chassis ground.

**Connector & terminal**  
**(B176) No. 8 — Chassis ground:**

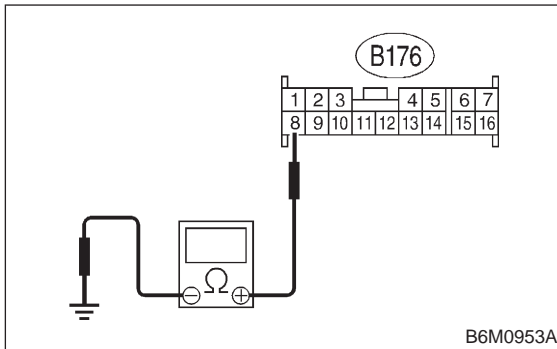

- CHECK** : **Is the resistance less than 10 Ω?**
- YES** : Go to step **6A1**.
- NO** : Repair wiring harness between keyless entry control module and chassis ground.