

6. Diagnostics Procedure

A: BASIC DIAGNOSTICS PROCEDURE

6A1 : CHECK SECURITY SYSTEM FUNCTION.

- 1) Perform basic diagnostics procedure of keyless entry system. <Ref. to 6-2c [T600].>
- 2) Perform pre-inspection. <Ref. to 6-2d [T200].>
- 3) Open all windows.
- 4) Remove ignition key from ignition switch.
- 5) Set the room light switch in the middle position.
- 6) Close all doors, rear gate and trunk lid.
- 7) Press the LOCK/ARM button one time.

- CHECK** : *Does the clearance light blink one time?*
- YES** : Go to step **6A2**.
- NO** : Go to step **6B1**.

6A2 : CHECK SECURITY SYSTEM FUNCTION.

Check if the security indicator light blinks.

- CHECK** : *Does the security indicator light blink every 2 seconds?*
- YES** : Go to step **6A3**.
- NO** : Go to step **6C1**.

6A3 : CHECK SECURITY SYSTEM FUNCTION.

Press the UNLOCK/DISARM button one time.

- CHECK** : *Does the clearance light blink two times?*
- YES** : Go to step **6A4**.
- NO** : Replace security control module. <Ref. to 6-2 [W2300].>

6A4 : CHECK SECURITY SYSTEM FUNCTION.

Check if the room light activates.

- CHECK** : *Does the room light turn on for 30 seconds, and then turn off?*
- YES** : Go to step **6A5**.
- NO** : Replace security control module. <Ref. to 6-2 [W2300].>

6A5 : CHECK SECURITY SYSTEM FUNCTION.

- 1) Unlock all doors with door locking switch in the front door.
- 2) Open the front left door.

- CHECK** : *Does the security indicator light blink every 1/8 seconds?*
- YES** : Go to step **6A6**.
- NO** : Go to step **6D1**.

6A6 : CHECK SECURITY SYSTEM FUNCTION.

Check if the clearance light activates.

- CHECK** : *Does the clearance light blinking remain?*
- YES** : Go to step **6A7**.
- NO** : Replace security control module. <Ref. to 6-2 [W2300].>

6A7 : CHECK SECURITY SYSTEM FUNCTION.

Check if the horn activates.

- CHECK** : *Does the horn sound remain?*
- YES** : Go to step **6A8**.
- NO** : Replace security control module. <Ref. to 6-2 [W2300].>

6A8 : CHECK SECURITY SYSTEM FUNCTION.

Turn on starter.

- CHECK** : *Does the starter motor activate?*
- YES** : Go to step **6E1**.
- NO** : Go to step **6A9**.

6A9 : CHECK SECURITY SYSTEM FUNCTION.

Close the front left door.

- CHECK** : *Does the horn sound and clearance light blinking deactivate, and starter motor activate after approximately 30 seconds?*
- YES** : Go to step **6A10**.
- NO** : Replace security control module. <Ref. to 6-2 [W2300].>

6-2d [T6A10] BODY ELECTRICAL SYSTEM (SECURITY SYSTEM)

6. Diagnostics Procedure

6A10 : CHECK SECURITY SYSTEM FUNCTION.

Check if the security indicator light activates.

CHECK : *Does the security indicator light blink every 2 seconds?*

YES : Go to step 6A11.

NO : Replace security control module. <Ref. to 6-2 [W2300].>

6A11 : CHECK SECURITY SYSTEM FUNCTION.

Open the front right door.

CHECK : *Does the security indicator light blink every 1/8 seconds, the horn sound, the clearance light blink, and the starter motor deactivate?*

YES : Go to step 6A12.

NO : Go to step 6F1.

6A12 : CHECK SECURITY SYSTEM FUNCTION.

Press the UNLOCK/DISARM button.

CHECK : *Does the security indicator light blink, the horn and clearance light deactivate, and the starter motor activate?*

YES : Go to step 6A13.

NO : Replace security control module. <Ref. to 6-2 [W2300].>

6A13 : CHECK SECURITY SYSTEM FUNCTION.

- 1) Close the front right door.
- 2) Press the LOCK/ARM button.
- 3) Open the rear left door.

CHECK : *Does the security indicator light blink every 1/8 seconds, the horn sound, the clearance light blink, and the starter motor deactivate?*

YES : Go to step 6A14.

NO : Go to step 6G1.

6A14 : CHECK SECURITY SYSTEM FUNCTION.

- 1) Close the rear left door.
- 2) Open the rear right door.

CHECK : *Does the security indicator light blink every 1/8 seconds, the horn sound, the clearance light blink, and the starter motor deactivate?*

YES : Go to step 6A15.

NO : Go to step 6H1.

6A15 : CHECK SECURITY SYSTEM FUNCTION.

Close the rear right door.

CHECK : *Is the vehicle type wagon?*

YES : Go to step 6A16.

NO : Go to step 6A17.

6A16 : CHECK SECURITY SYSTEM FUNCTION.

Open the rear gate.

CHECK : *Does the security indicator light blink every 1/8 seconds, the horn sound, the clearance light blink, and the starter motor deactivate?*

YES : Go to step 6A18.

NO : Go to step 6I1.

6A17 : CHECK SECURITY SYSTEM FUNCTION.

Open the trunk lid.

CHECK : *Does the security indicator light blink every 1/8 seconds, the horn sound, the clearance light blink, and the starter motor deactivate?*

YES : Go to step 6A18.

NO : Go to step 6J1.

6A18 : PERFORM IMPACT SENSITIVITY TEST.

- 1) Close the rear gate or trunk lid.
- 2) Close all windows.
- 3) Cover the hood with a blanket.
- 4) Perform arming.
- 5) Perform impact sensitivity test.

Dimension:

A: 600 mm (23.62 in)

B: 420 mm (16.54 in)

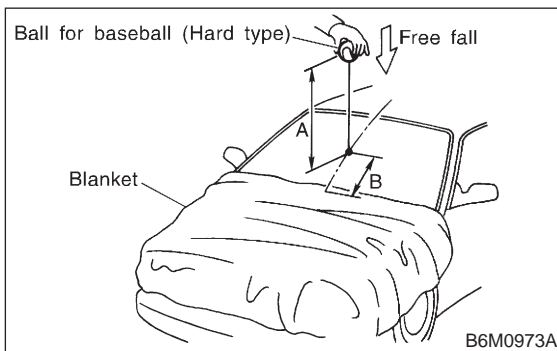

- CHECK** : **Does the horn chirp?**
- YES** : Go to step **6A19**.
- NO** : Go to step **6K1**.

6A19 : CHECK PASSIVE ARM.

- 1) Remove the driver's side sill cover. <Ref. to 5-3 [W5A1].>
- 2) Connect the white connector (1-pin) at front pillar lower.
- 3) Close all doors, rear gate or trunk lid.

- CHECK** : **Does the arming automatically function after 1 minute?**
- YES** : Go to step **6A20**.
- NO** : Go to step **6L1**.

6A20 : CHECK BATTERY DISCONNECT PROTECTION.

- 1) Press the UNLOCK/DISARM button.
- 2) Connect the white connector (1-pin) at front pillar lower.
- 3) Install the driver's side sill cover. <Ref. to 5-3 [W5A1].>
- 4) Open the front hood.
- 5) Press the LOCK/ARM button.
- 6) Disconnect the ground cable from battery.
- 7) Connect the ground cable to battery.

- CHECK** : **Does re-arming function automatically?**
- YES** : End of basic diagnostics procedure. Press the UNLOCK/DISARM button, and then close all doors, rear gate or trunk lid. Perform ignition switch position turned LOCK to ON to LOCK.
- NO** : Replace security control module. <Ref. to 6-2 [W2300].>

B: DIAGNOSTICS ITEM 1

6B1 : CHECK FUSE NO. 23.

Remove and visually check fuse No. 23 (in main fuse box).

- CHECK** : **Is fuse No. 23 blown?**
- YES** : Replace fuse (20 A).
- NO** : Go to step **6B2**.

6B2 : CHECK FUSE NO. 5.

Remove and visually check fuse No. 5 (in fuse box).

- CHECK** : **Is fuse No. 5 blown?**
- YES** : Replace fuse (10 A).
- NO** : Go to step **6B3**.

6B3 : CHECK CLEARANCE LIGHT BULB.

Remove and visually check each clearance light bulb.

- CHECK** : **Is the bulb blown?**
- YES** : Replace clearance light bulb.
- NO** : Go to step **6B4**.

6-2d [T6B4] BODY ELECTRICAL SYSTEM (SECURITY SYSTEM)

6. Diagnostics Procedure

6B4 : CHECK POWER SUPPLY FOR CLEARANCE LIGHT.

Measure voltage between main fuse box connector (F35) and chassis ground.

Connector & terminal

(F35) No. 6 (+) — Chassis ground (-):

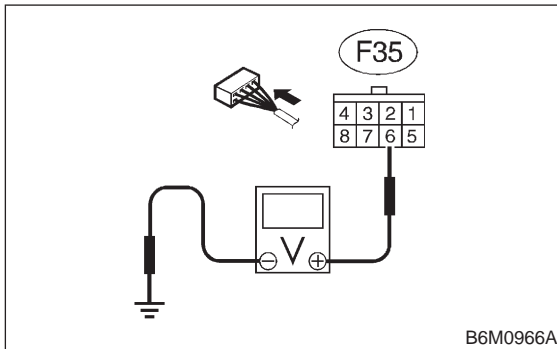

B6M0966A

- CHECK** : Is the voltage more than 10 V?
YES : Go to step 6B5.
NO : Repair wiring harness between main fuse box and battery.

6B5 : CHECK POWER SUPPLY FOR CLEARANCE LIGHT.

- 1) Disconnect connector from security control module.
- 2) Measure voltage between security control module connector (B93) and chassis ground.

Connector & terminal

(B93) No. 11 (+) — Chassis ground (-):

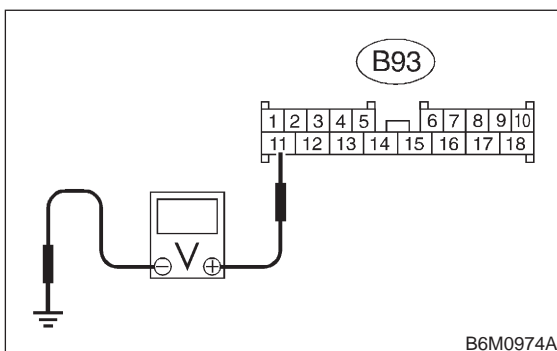

B6M0974A

- CHECK** : Is the voltage more than 10 V?
YES : Go to step 6B6.
NO : Repair wiring harness between security control module and main fuse box.

6B6 : CHECK HARNESS CONNECTOR BETWEEN SECURITY CONTROL MODULE AND MAIN FUSE BOX.

- 1) Disconnect connector (B52) from main fuse box.
- 2) Measure resistance between security control module connector (B93) and main fuse box connector (B52).

Connector & terminal

(B93) No. 12 — (B52) No. 8:

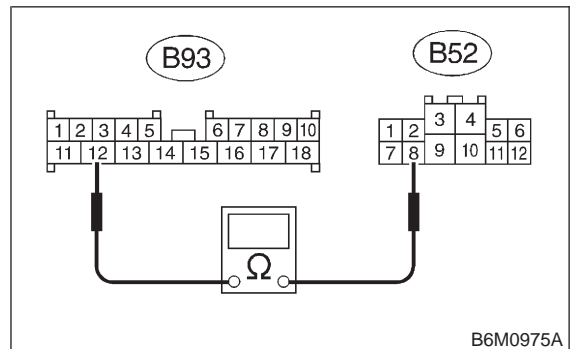

B6M0975A

- CHECK** : Is the resistance less than 10 Ω?
YES : Go to step 6B7.
NO : Repair wiring harness between security control module and main fuse box.

6B7 : CHECK MAIN FUSE BOX CIRCUIT.

- 1) Connect connector (B52) to main fuse box.
- 2) Measure resistance between main fuse box and connector (B52).

Connector & terminal

(B52) No. 7 — No. 8:

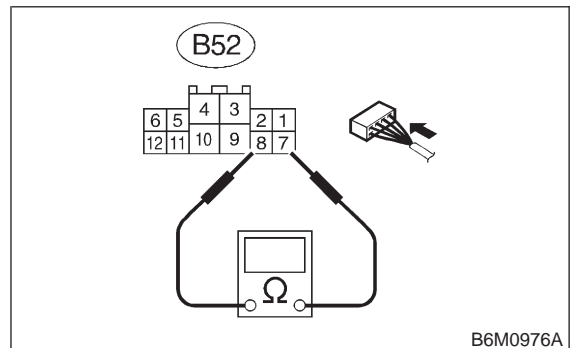

B6M0976A

- CHECK** : Is the resistance less than 10 Ω?
YES : Go to step 6B8.
NO : Repair or replace main fuse box.

6B8 : CHECK MAIN FUSE BOX CIRCUIT.

Measure resistance between main fuse box connector (B52) and (F40).

Connector & terminal

(B52) No. 8 — (F40) No. 1:

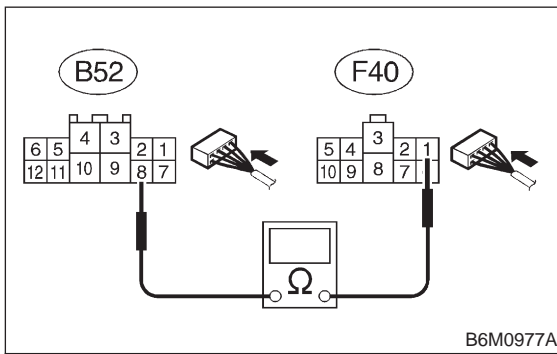

B6M0977A

- CHECK** : Is the resistance less than 10 Ω?
- YES** : Go to step 6B9.
- NO** : Repair or replace main fuse box.

6B9 : CHECK HARNESS CONNECTOR BETWEEN FRONT CLEARANCE LIGHT AND MAIN FUSE BOX.

- 1) Disconnect connector from front clearance light RH and main fuse box.
- 2) Measure resistance between front clearance light RH and connector (F3) and main fuse box connector (F40).

Connector & terminal

(F3) No. 1 — (F40) No. 1:

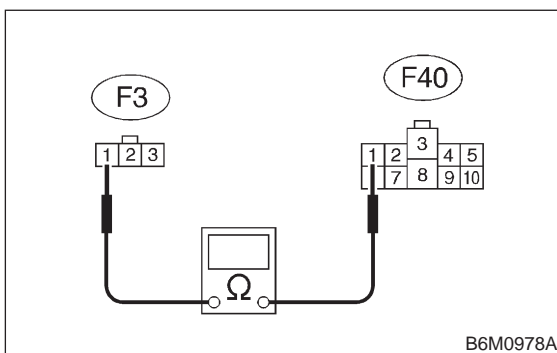

B6M0978A

- CHECK** : Is the resistance less than 10 Ω?
- YES** : Go to step 6B10.
- NO** : Repair wiring harness between front clearance light RH and main fuse box.

6B10 : CHECK HARNESS CONNECTOR BETWEEN FRONT CLEARANCE LIGHT AND MAIN FUSE BOX.

- 1) Disconnect connector from front clearance light LH.
- 2) Measure resistance between front clearance light LH connector (F19) and main fuse box connector (F40).

Connector & terminal

(F19) No. 1 — (F40) No. 1:

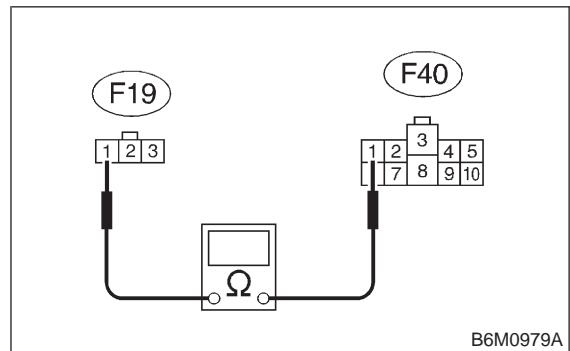

B6M0979A

- CHECK** : Is the resistance less than 10 Ω?
- YES** : Go to step 6B11.
- NO** : Repair wiring harness between front clearance light LH and main fuse box.

6B11 : CHECK HARNESS CONNECTOR BETWEEN FRONT CLEARANCE LIGHT AND CHASSIS GROUND.

Measure resistance between front clearance light RH connector (F3) and chassis ground.

Connector & terminal

(F3) No. 2 (+) — Chassis ground (-):

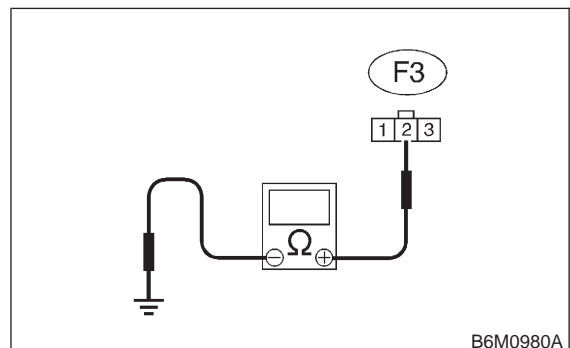

B6M0980A

- CHECK** : Is the resistance less than 10 Ω?
- YES** : Go to step 6B12.
- NO** : Repair wiring harness between front clearance light RH and chassis ground.

6-2d [T6B12] BODY ELECTRICAL SYSTEM (SECURITY SYSTEM)

6. Diagnostics Procedure

6B12 : CHECK HARNESS CONNECTOR BETWEEN FRONT CLEARANCE LIGHT AND CHASSIS GROUND.

Measure resistance between front clearance light LH connector (F19) and chassis ground.

Connector & terminal

(F19) No. 2 (+) — Chassis ground (-):

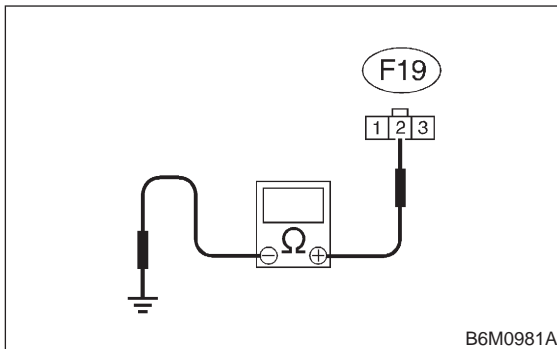

B6M0981A

CHECK : Is the resistance less than 10 Ω?

YES : Go to step 6B13.

NO : Repair wiring harness between front clearance light LH and chassis ground.

6B13 : CHECK HARNESS CONNECTOR BETWEEN REAR CLEARANCE LIGHT AND MAIN FUSE BOX.

1) Disconnect connector from rear clearance light RH and main fuse box.

2) Measure resistance between rear clearance light RH connector (R26) and main fuse box connector (B52).

Connector & terminal

(R26) No. 3 (sedan), No. 4 (wagon) — (B52) No. 7:

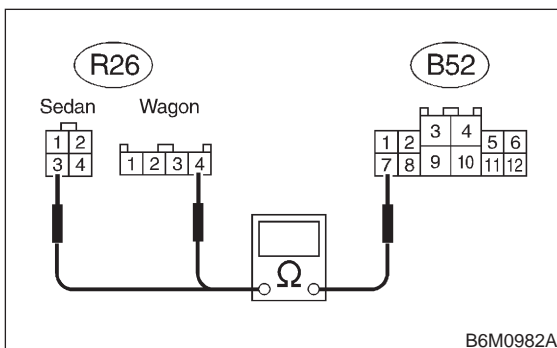

B6M0982A

CHECK : Is the resistance less than 10 Ω?

YES : Go to step 6B14.

NO : Repair wiring harness between rear clearance light RH and main fuse box.

6B14 : CHECK HARNESS CONNECTOR BETWEEN REAR CLEARANCE LIGHT AND MAIN FUSE BOX.

1) Disconnect connector from rear clearance light LH.

2) Measure resistance between rear clearance light LH connector (R28) and main fuse box connector (B52).

Connector & terminal

(R28) No. 3 (sedan), No. 4 (wagon) — (B52) No. 7:

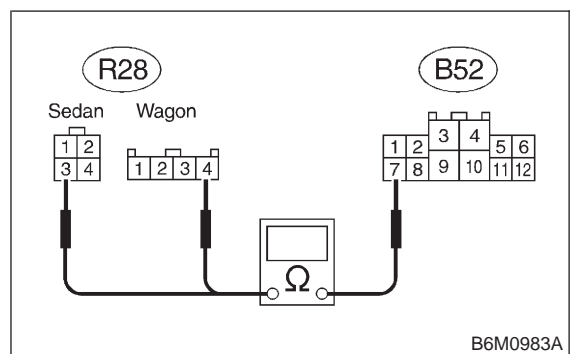

B6M0983A

CHECK : Is the resistance less than 10 Ω?

YES : Go to step 6B15.

NO : Repair wiring harness between rear clearance light LH and main fuse box.

6B15 : CHECK HARNESS CONNECTOR BETWEEN REAR CLEARANCE LIGHT AND CHASSIS GROUND.

Measure resistance between rear clearance light RH connector (R26) and chassis ground.

Connector & terminal

(R26) No. 2 (+) — Chassis ground (-):

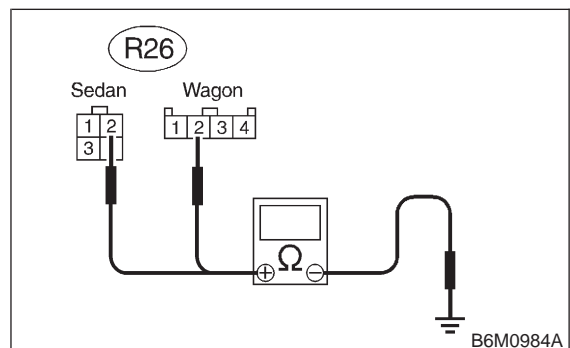

B6M0984A

CHECK : Is the resistance less than 10 Ω?

YES : Go to step 6B16.

NO : Repair wiring harness between rear clearance light RH and chassis ground.

6B16 : CHECK HARNESS CONNECTOR BETWEEN REAR CLEARANCE LIGHT AND CHASSIS GROUND.

Measure resistance between rear clearance light LH connector (R28) and chassis ground.

Connector & terminal

(R28) No. 2 (+) — Chassis ground (-):

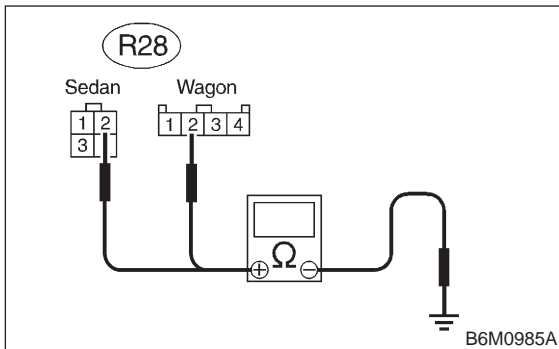

- CHECK** : **Is the resistance less than 10 Ω?**
- YES** : Replace security control module. <Ref. to 6-2 [W2300].>
- NO** : Repair wiring harness between rear clearance light LH and chassis ground.

C: DIAGNOSTICS ITEM 2

6C1 : CHECK SECURITY INDICATOR LIGHT COMES ON.

- 1) Disconnect connector from security control module.
- 2) Connect security control module connector (B93) and chassis ground.

Connector & terminal

(B93) No. 16 (+) — Chassis ground (-):

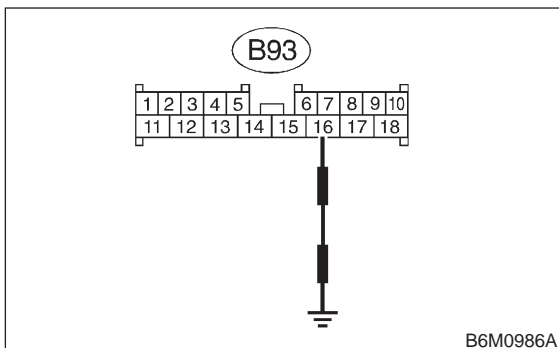

- CHECK** : **Does the indicator light come on?**
- YES** : Replace security control module. <Ref. to 6-2 [W2300].>
- NO** : Go to step **6C2**.

6C2 : CHECK POWER SUPPLY FOR SECURITY INDICATOR LIGHT.

- 1) Disconnect connector from security indicator light.
- 2) Measure voltage between security indicator light connector (i8) and chassis ground.

Connector & terminal

(i8) No. 2 (+) — Chassis ground (-):

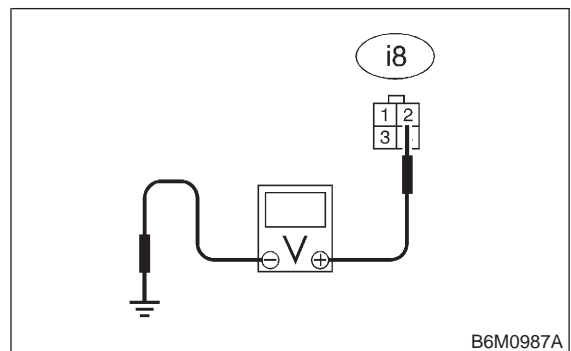

- CHECK** : **Is the voltage more than 10 V?**
- YES** : Go to step **6C3**.
- NO** : Repair wiring harness between security indicator light and main fuse box.

6C3 : CHECK HARNESS CONNECTOR BETWEEN SECURITY INDICATOR LIGHT AND SECURITY CONTROL MODULE.

Measure resistance between security indicator light connector (i8) and security control module (B93).

Connector & terminal

(i8) No. 4 — (B93) No. 16:

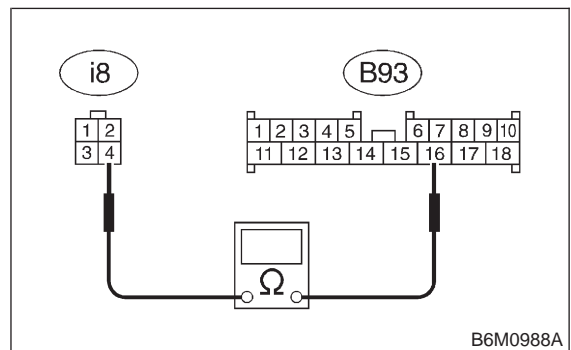

- CHECK** : **Is the resistance less than 10 Ω?**
- YES** : Replace LED bulb.
- NO** : Repair wiring harness between security indicator light and security control module.

6-2d [T6D1] BODY ELECTRICAL SYSTEM (SECURITY SYSTEM)

6. Diagnostics Procedure

D: DIAGNOSTICS ITEM 3

6D1 : CHECK HARNESS CONNECTOR BETWEEN SECURITY CONTROL MODULE AND COMBINATION METER.

- 1) Disconnect connector from security control module and combination meter.
- 2) Measure resistance between security control module connector (B93) and combination meter connector (i12).

Connector & terminal

(B93) No. 5 — (i12) No. 8:

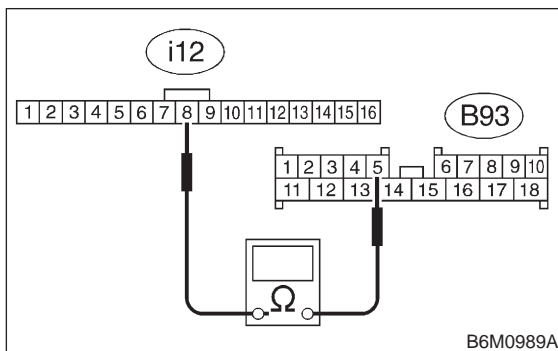

CHECK : Is the resistance less than 10 Ω?

YES : Go to step 6D2.

NO : Repair wiring harness between security control module and combination meter.

6D2 : CHECK HARNESS CONNECTOR BETWEEN FRONT DOOR SWITCH LH AND COMBINATION METER.

- 1) Disconnect connector from front door switch LH.
- 2) Measure resistance between front door switch LH (R9) and combination meter connector (i12).

Connector & terminal

(R9) No. 1 — (i12) No. 4:

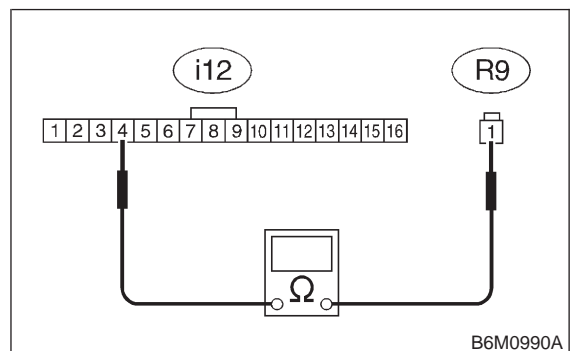

CHECK : Is the resistance less than 10 Ω?

YES : Go to step 6D3.

NO : Repair wiring harness between front door switch LH and combination meter.

6D3 : CHECK COMBINATION METER CIRCUIT.

- 1) Remove combination meter.
<Ref. to 6-2 [W1400].>
- 2) Measure resistance between combination meter terminals.

Terminals

No. 8 — No. 4:

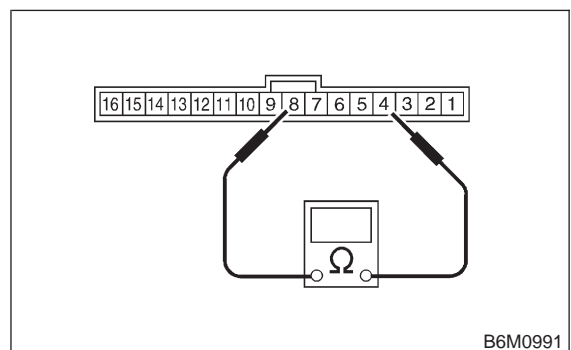

CHECK : Is the resistance less than 10 Ω?

YES : Replace security control module. <Ref. to 6-2 [W2300].>

NO : Repair or replace combination meter. <Ref. to 6-2 [W1400].>

E: DIAGNOSTICS ITEM 4

6E1 : CHECK INPUT SIGNAL FOR STARTER MOTOR.

- 1) Disconnect connector from starter motor.
- 2) Turn ignition switch to START.
- 3) Measure voltage between starter motor connector (B14) and engine ground.

Connector & terminal

(B14) No. 1 (+) — Engine ground (-):

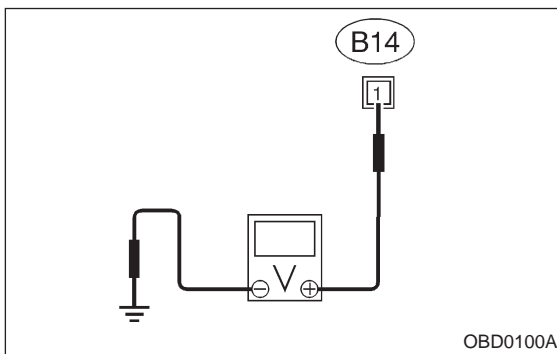

NOTE:

- On AT vehicles, place the selector lever in the P or N position.
- On MT vehicles, depress the clutch pedal.

- CHECK** : **Is the voltage more than 10 V?**
YES : Go to step **6E2**.
NO : Go to step **6E3**.

6E2 : CHECK GROUND CIRCUIT OF STARTER MOTOR.

- 1) Turn ignition switch to OFF.
- 2) Disconnect terminal from starter motor.
- 3) Measure resistance between ground cable terminal and engine ground.

- CHECK** : **Is the resistance less than 5 Ω?**
YES : Check starter motor. <Ref. to 6-1 [W100].>
NO : Repair or replace ground cable.

6E3 : CHECK FUSIBLE LINK 1.25B.

Remove and visually check the fusible link 1.25B (in main fuse box).

- CHECK** : **Is fusible link blown?**
YES : Replace fusible link 1.25B.
NO : Go to step **6E4**.

6E4 : CHECK FUSE SBF-4.

Remove and visually check the fuse SBF-4 (in main fuse box).

- CHECK** : **Is fuse SBF-4 blown?**
YES : Replace SBF fuse (45 A).
NO : Go to step **6E5**.

6E5 : CHECK INTERRUPT RELAY.

- 1) Turn ignition switch to OFF.
- 2) Remove interrupt relay (Near the cruise control module).
- 3) Check continuity between interrupt relay terminals.

Terminals

No. 1 — No. 4:

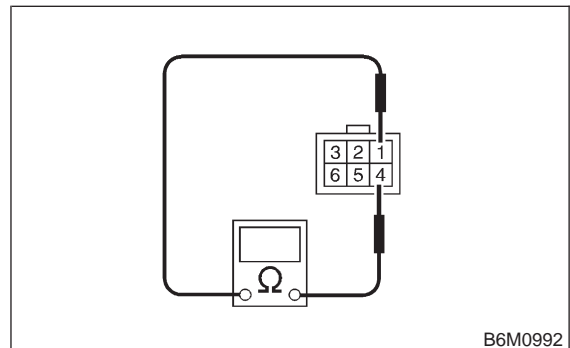

- CHECK** : **Does continuity exist?**
YES : Go to step **6E6**.
NO : Replace interrupt relay.

6-2d [T6E6] BODY ELECTRICAL SYSTEM (SECURITY SYSTEM)

6. Diagnostics Procedure

6E6 : CHECK INTERRUPT RELAY.

Check continuity between interrupt relay terminals.

Terminals

No. 2 — No. 6:

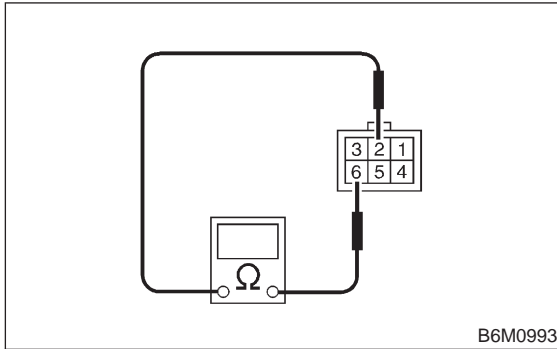

CHECK : **Does continuity exist?**

YES : Go to step **6E7**.

NO : Replace interrupt relay.

6E7 : CHECK INTERRUPT RELAY.

1) Connect the battery to interrupt relay terminals No. 1 and No. 4.

2) Check continuity between interrupt relay terminals.

Terminals

No. 2 — No. 6:

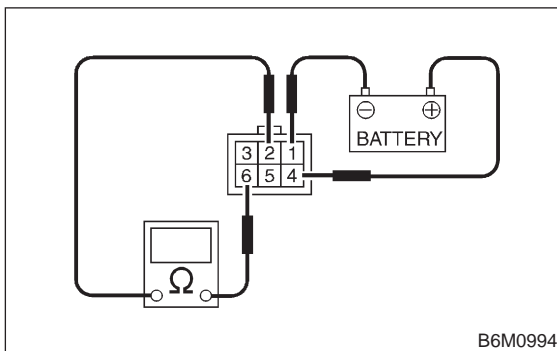

CHECK : **Does continuity exist?**

YES : Replace interrupt relay.

NO : Go to step **6E8**.

6E8 : CHECK HARNESS CONNECTOR BETWEEN BATTERY AND SECURITY CONTROL MODULE.

- 1) Install the SBF-4 to main fuse box.
- 2) Install the interrupt relay.
- 3) Disconnect connector from security control module.
- 4) Turn ignition switch to START.
- 5) Measure voltage between security control module connector (B93) and chassis ground.

Connector & terminal

(B93) No. 15 (+) — Chassis ground (-):

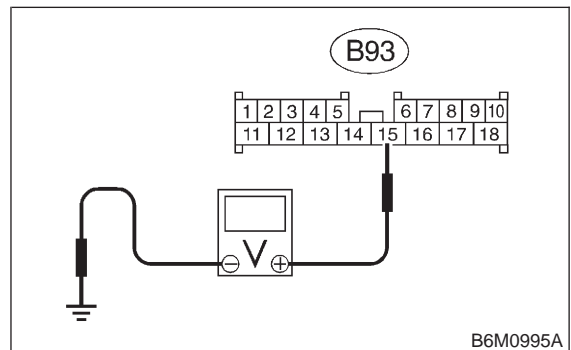

CHECK : **Is the voltage more than 10 V?**

YES : Go to step **6E9**.

NO : Repair wiring harness between security control module and battery.

6E9 : CHECK TRANSMISSION TYPE.

CHECK : **Is the transmission type AT?**

YES : Go to step **6E10**.

NO : Go to step **6E13**.

6E10 : CHECK HARNESS CONNECTOR BETWEEN INTERRUPT RELAY AND INHIBITOR SWITCH.

- 1) Turn ignition switch to OFF.
- 2) Disconnect connector from inhibitor switch.
- 3) Turn ignition switch to START.
- 4) Measure voltage between inhibitor switch connector (T7) and chassis ground.

Connector & terminal

(T7) No. 1 (+) — Chassis ground (-):

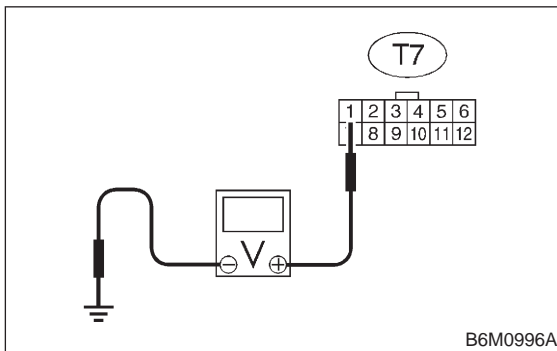

- CHECK** : **Is the voltage more than 10 V?**
- YES** : Go to step **6E11**.
- NO** : Repair wiring harness between interrupt relay and inhibitor switch.

6E11 : CHECK INHIBITOR SWITCH.

- 1) Place the selector lever in the P or N position.
- 2) Measure resistance between inhibitor switch terminals.

Terminals

No. 1 — No. 2:

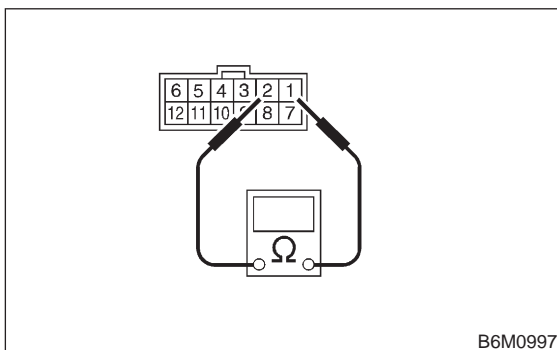

- CHECK** : **Is the resistance less than 1 Ω?**
- YES** : Go to step **6E12**.
- NO** : Replace inhibitor switch. <Ref. to 3-2 [W2C0].>

6E12 : CHECK HARNESS BETWEEN INHIBITOR SWITCH AND STARTER MOTOR.

Measure resistance between inhibitor switch connector (T7) and starter motor connector (B14).

Connector & terminal

(T7) No. 2 — (B14) No. 1:

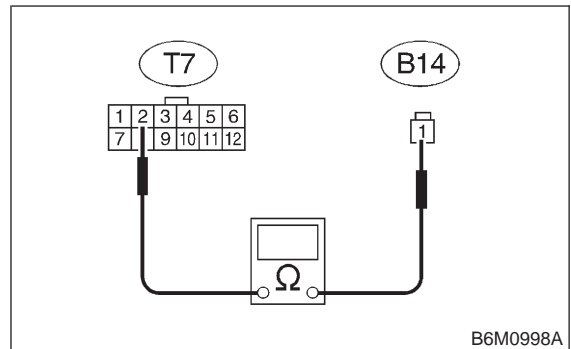

- CHECK** : **Is the resistance less than 10 Ω?**
- YES** : Replace security control module. <Ref. to 6-2 [W2300].>
- NO** : Repair wiring harness between inhibitor switch and starter motor.

6E13 : CHECK STARTER INTERLOCK RELAY.

- 1) Turn ignition switch to OFF.
- 2) Remove starter interlock relay.
- 3) Check continuity between starter interlock relay terminals.

Terminals

No. 1 — No. 2:

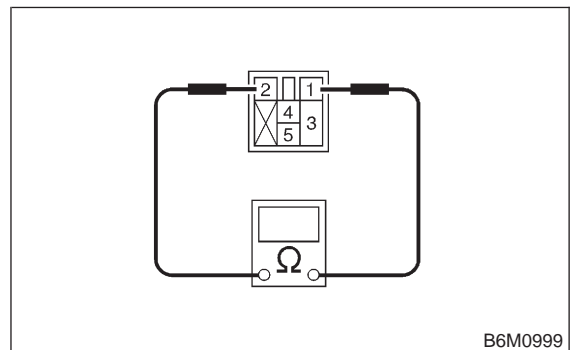

- CHECK** : **Does continuity exist?**
- YES** : Go to step **6E14**.
- NO** : Replace starter interlock relay.

6-2d [T6E14] BODY ELECTRICAL SYSTEM (SECURITY SYSTEM)

6. Diagnostics Procedure

6E14 : CHECK STARTER INTERLOCK RELAY.

Check continuity between starter interlock relay terminals.

Terminals

No. 3 — No. 4:

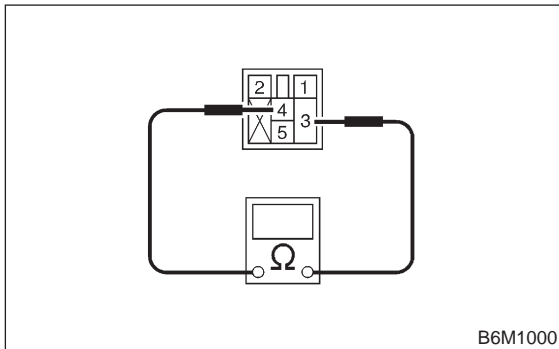

- CHECK** : Does continuity exist?
YES : Replace starter interlock relay.
NO : Go to step 6E15.

6E15 : CHECK STARTER INTERLOCK RELAY.

- 1) Connect the battery to starter interlock relay terminals No. 1 and No. 2.
- 2) Check continuity between starter interlock relay terminals.

Terminals

No. 3 — No. 4:

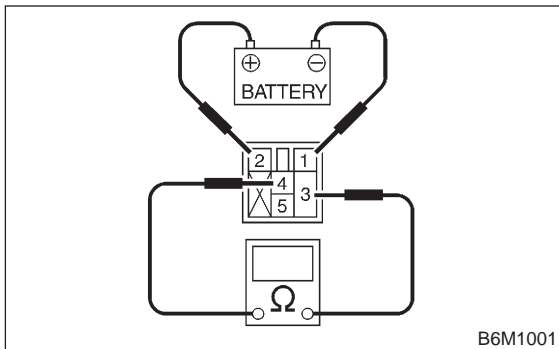

- CHECK** : Does continuity exist?
YES : Go to step 6E16.
NO : Replace starter interlock relay.

6E16 : CHECK CLUTCH SWITCH.

- 1) Install starter interlock relay.
- 2) Measure resistance between clutch switch connector (B106), (B107) terminals while depressing the clutch pedal.

Connector & terminal

- With cruise control (B107) No. 1 — No. 2:
- Without cruise control (B106) No. 1 — No. 2:

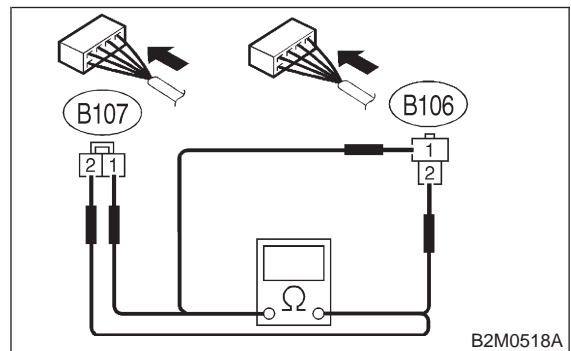

- CHECK** : Is the resistance less than 10 Ω?
YES : Go to step 6E17.
NO : Replace clutch switch.

6E17 : CHECK HARNESS BETWEEN INTERRUPT RELAY AND STARTER MOTOR.

- 1) Disconnect connector from starter motor.
- 2) Turn ignition switch to START.
- 3) Measure voltage between starter motor connector (B14) and chassis ground while depressing the clutch pedal.

Connector & terminal
(B14) No. 1 (+) — Chassis ground (-):

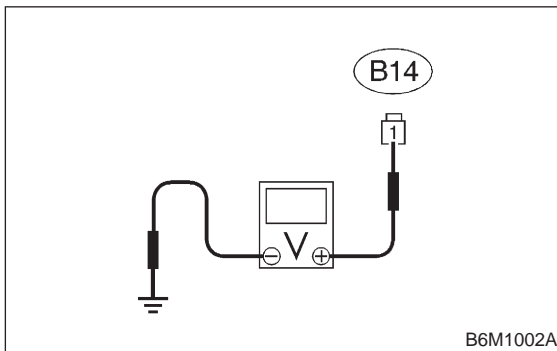

- CHECK** : **Is the voltage more than 10 V?**
- YES** : Replace security control module. <Ref. to 6-2 [W2300].>
- NO** : Repair wiring harness between interrupt relay and starter motor.

F: DIAGNOSTICS ITEM 5

6F1 : CHECK HARNESS CONNECTOR BETWEEN SECURITY CONTROL MODULE AND COMBINATION METER.

- 1) Disconnect connector from security control module and combination meter.
- 2) Measure resistance between security control module connector (B93) and combination meter connector (i12).

Connector & terminal
(B93) No. 5 — (i12) No. 8:

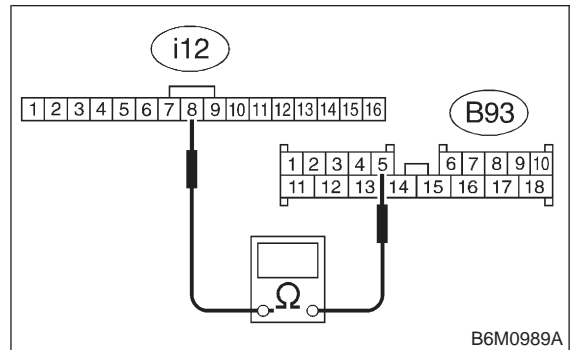

- CHECK** : **Is the resistance less than 10 Ω?**
- YES** : Go to step 6F2.
- NO** : Repair wiring harness between security control module and combination meter.

6-2d [T6F2] BODY ELECTRICAL SYSTEM (SECURITY SYSTEM)

6. Diagnostics Procedure

6F2 : CHECK HARNESS CONNECTOR BETWEEN FRONT DOOR SWITCH RH AND COMBINATION METER.

- 1) Disconnect connector from front door switch RH.
- 2) Measure resistance between front door switch RH (R12) and combination meter connector (i12).

Connector & terminal

(R12) No. 1 — (i12) No. 5:

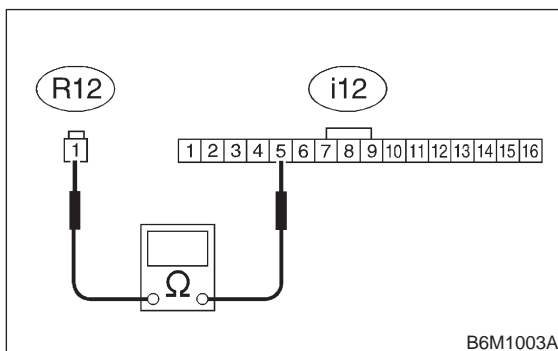

- CHECK** : Is the resistance less than 10 Ω?
- YES** : Go to step 6F3.
- NO** : Repair wiring harness between front door switch RH and combination meter.

6F3 : CHECK COMBINATION METER CIRCUIT.

- 1) Remove combination meter.
<Ref. to 6-2 [W1400].>
- 2) Measure resistance between combination meter terminals.

Terminals

No. 8 — No. 5:

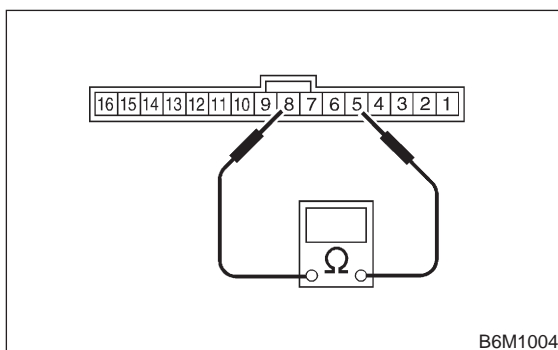

- CHECK** : Is the resistance less than 10 Ω?
- YES** : Replace security control module. <Ref. to 6-2 [W2300].>
- NO** : Repair or replace combination meter. <Ref. to 6-2 [W1400].>

G: DIAGNOSTIC ITEM 6

6G1 : CHECK HARNESS CONNECTOR BETWEEN SECURITY CONTROL MODULE AND COMBINATION METER.

- 1) Disconnect connector from security control module and combination meter.
- 2) Measure resistance between security control module connector (B93) and combination meter connector (i12).

Connector & terminal

(B93) No. 5 — (i12) No. 8:

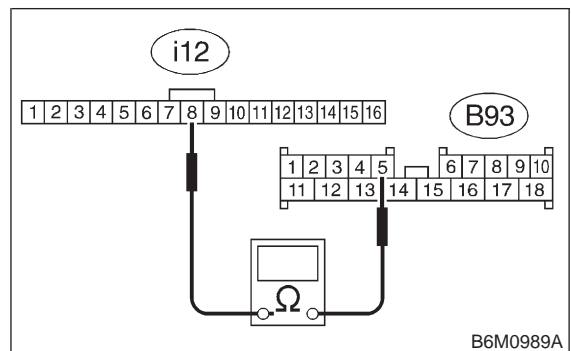

- CHECK** : Is the resistance less than 10 Ω?
- YES** : Go to step 6G2.
- NO** : Repair wiring harness between security control module and combination meter.

6G2 : CHECK HARNESS CONNECTOR BETWEEN REAR DOOR SWITCH LH AND COMBINATION METER.

- 1) Disconnect connector from rear door switch LH.
- 2) Measure resistance between rear door switch LH (R22) and combination meter connector (i12).

Connector & terminal

(R22) No. 1 — (i12) No. 9:

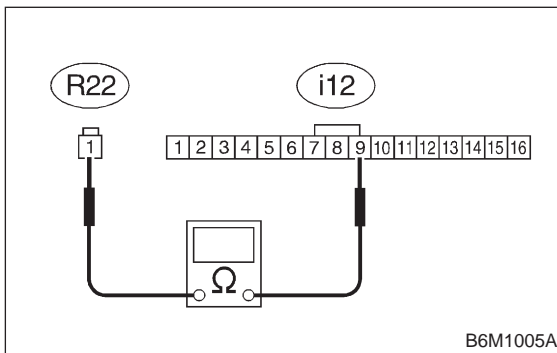

B6M1005A

- CHECK** : Is the resistance less than 10 Ω?
- YES** : Go to step 6G3.
- NO** : Repair wiring harness between rear door switch LH and combination meter.

6G3 : CHECK COMBINATION METER CIRCUIT.

- 1) Remove combination meter.
<Ref. to 6-2 [W1400].>
- 2) Measure resistance between combination meter terminals.

Terminals

No. 8 — No. 9:

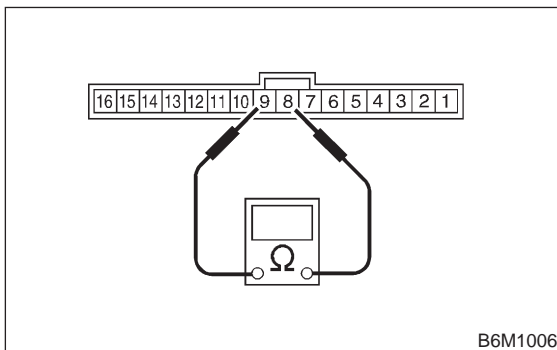

B6M1006

- CHECK** : Is the resistance less than 10 Ω?
- YES** : Replace security control module. <Ref. to 6-2 [W2300].>
- NO** : Repair or replace combination meter. <Ref. to 6-2 [W1400].>

H: DIAGNOSTIC ITEM 7

6H1 : CHECK HARNESS CONNECTOR BETWEEN SECURITY CONTROL MODULE AND COMBINATION METER.

- 1) Disconnect connector from security control module and combination meter.
- 2) Measure resistance between security control module connector (B93) and combination meter connector (i12).

Connector & terminal

(B93) No. 5 — (i12) No. 8:

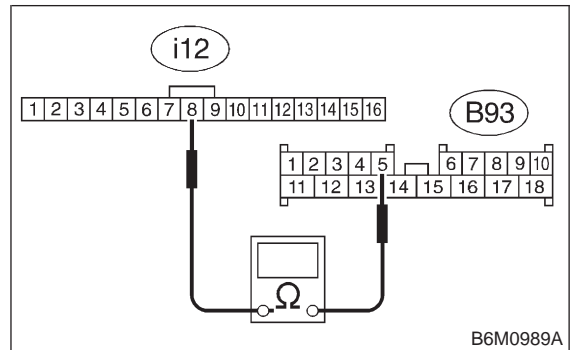

B6M0989A

- CHECK** : Is the resistance less than 10 Ω?
- YES** : Go to step 6H2.
- NO** : Repair wiring harness between security control module and combination meter.

6-2d [T6H2] BODY ELECTRICAL SYSTEM (SECURITY SYSTEM)

6. Diagnostics Procedure

6H2 : CHECK HARNESS CONNECTOR BETWEEN REAR DOOR SWITCH RH AND COMBINATION METER.

- 1) Disconnect connector from rear door switch RH.
- 2) Measure resistance between rear door switch RH (R16) and combination meter connector (i12).

Connector & terminal

(R16) No. 1 — (i12) No. 12:

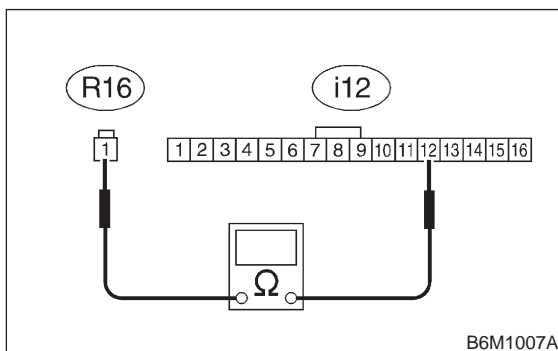

- CHECK** : Is the resistance less than 10 Ω?
- YES** : Go to step 6H3.
- NO** : Repair wiring harness between rear door switch RH and combination meter.

6H3 : CHECK COMBINATION METER CIRCUIT.

- 1) Remove combination meter.
<Ref. to 6-2 [W1400].>
- 2) Measure resistance between combination meter terminals.

Terminals

No. 8 — No. 12:

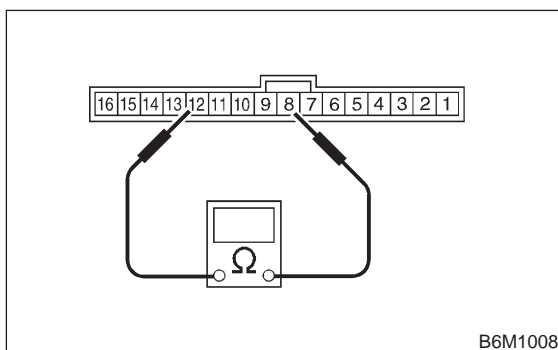

- CHECK** : Is the resistance less than 10 Ω?
- YES** : Replace security control module. <Ref. to 6-2 [W2300].>
- NO** : Repair or replace combination meter. <Ref. to 6-2 [W1400].>

I: DIAGNOSTIC ITEM 8

6I1 : CHECK HARNESS CONNECTOR BETWEEN REAR GATE LATCH SWITCH AND SECURITY CONTROL MODULE.

- 1) Disconnect connector from rear gate latch switch and security control module.
- 2) Measure resistance between rear gate latch switch (D46) and security control module connector (B93).

Connector & terminal

(D46) No. 1 — (B93) No. 4:

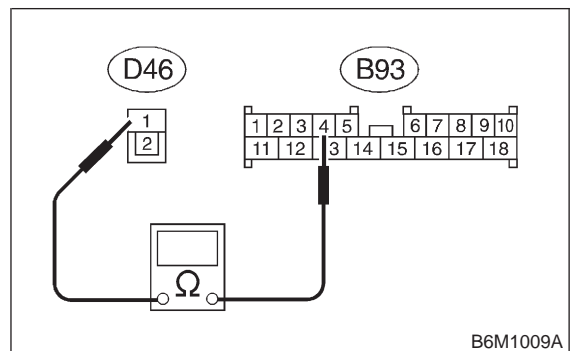

- CHECK** : Is the resistance less than 10 Ω?
- YES** : Go to step 6I2.
- NO** : Repair wiring harness between rear gate latch switch and security control module.

6I2 : CHECK HARNESS CONNECTOR BETWEEN REAR GATE LATCH SWITCH AND CHASSIS GROUND.

Measure resistance between rear gate latch switch (D46) and chassis ground.

Connector & terminal
(D46) No. 2 (+) — Chassis ground (-):

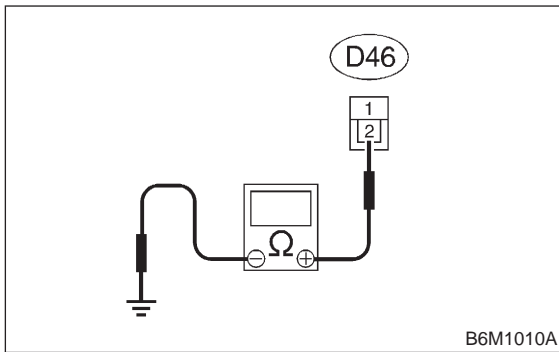

- CHECK** : **Is the resistance less than 10 Ω?**
- YES** : Replace security control module. <Ref. to 6-2 [W2300].>
- NO** : Repair wiring harness between rear gate latch switch and chassis ground.

J: DIAGNOSTIC ITEM 9

6J1 : CHECK HARNESS CONNECTOR BETWEEN TRUNK ROOM LIGHT SWITCH AND SECURITY CONTROL MODULE.

- 1) Disconnect connector from trunk room light switch and security control module.
- 2) Measure resistance between trunk room light switch (R27) and security control module connector (B93).

Connector & terminal
(R27) No. 1 — (B93) No. 4:

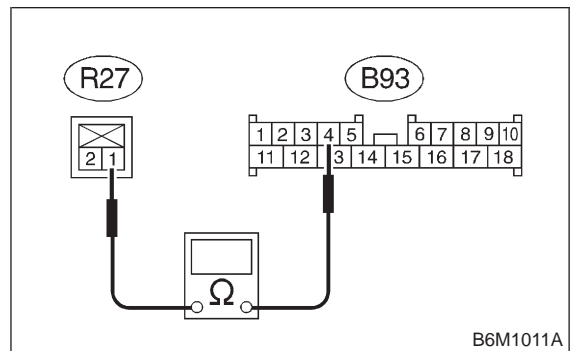

- CHECK** : **Is the resistance less than 10 Ω?**
- YES** : Replace security control module. <Ref. to 6-2 [W2300].>
- NO** : Repair wiring harness between trunk room light switch and security control module.

6-2d [T6K1] BODY ELECTRICAL SYSTEM (SECURITY SYSTEM)

6. Diagnostics Procedure

K: DIAGNOSTIC ITEM 10

6K1 : CHECK SECURITY CONTROL MODULE.

Check and ensure that security control module is installed on the bracket. <Ref. to 6-2 [W2300].>

CHECK : *Is the security control module securely installed?*

YES : Go to step **6K2**.

NO : Securely install security control module. <Ref. to 6-2 [W2300].>

6K2 : ADJUST SENSITIVITY.

1) Adjust the sensitivity adjust screw in security control module.

NOTE:

After adjusting, be sure to plug the adjust screw hole.

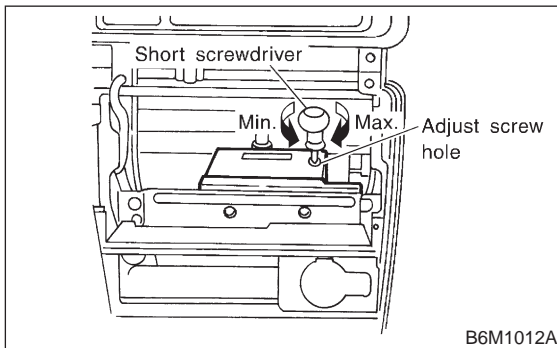

2) Perform impact sensitivity test. <Ref. to 6-2d [T6A18].>

CHECK : *Is the sensitivity adjustment possible?*

YES : Impact sensitivity is normal.

NO : Replace security control module. <Ref. to 6-2 [W2300].>

L: DIAGNOSTIC ITEM 11

6L1 : CHECK PASSIVE ARM CIRCUIT.

1) Connect connector (B183) and (B184) at front pillar lower.

2) Disconnect connector from security control module.

3) Measure resistance between security control module (B93) and chassis ground.

Connector & terminal

(B93) No. 3 (+) — Chassis ground (-):

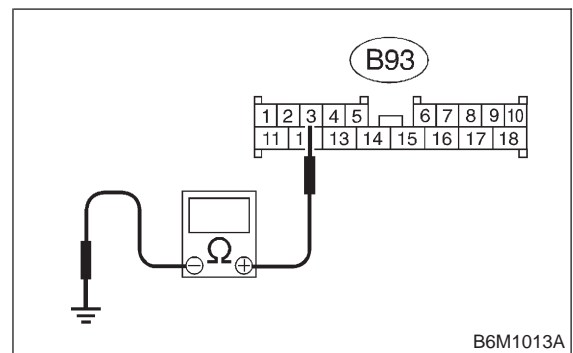

CHECK : *Is the resistance less than 10 Ω?*

YES : Replace security control module. <Ref. to 6-2 [W2300].>

NO : Repair wiring harness between security control module and chassis ground.