

### 8. Diagnostics for CHECK ENGINE Malfunction Indicator Lamp (MIL) [2500 cc Model]

#### A: CHECK ENGINE MALFUNCTION INDICATOR LAMP (MIL) DOES NOT COME ON.

- **DIAGNOSIS:**
  - The CHECK ENGINE malfunction indicator lamp (MIL) circuit is open or shorted.
- **TROUBLE SYMPTOM:**
  - When ignition switch is turned ON (engine OFF), MIL does not come on.
- **WIRING DIAGRAM:**

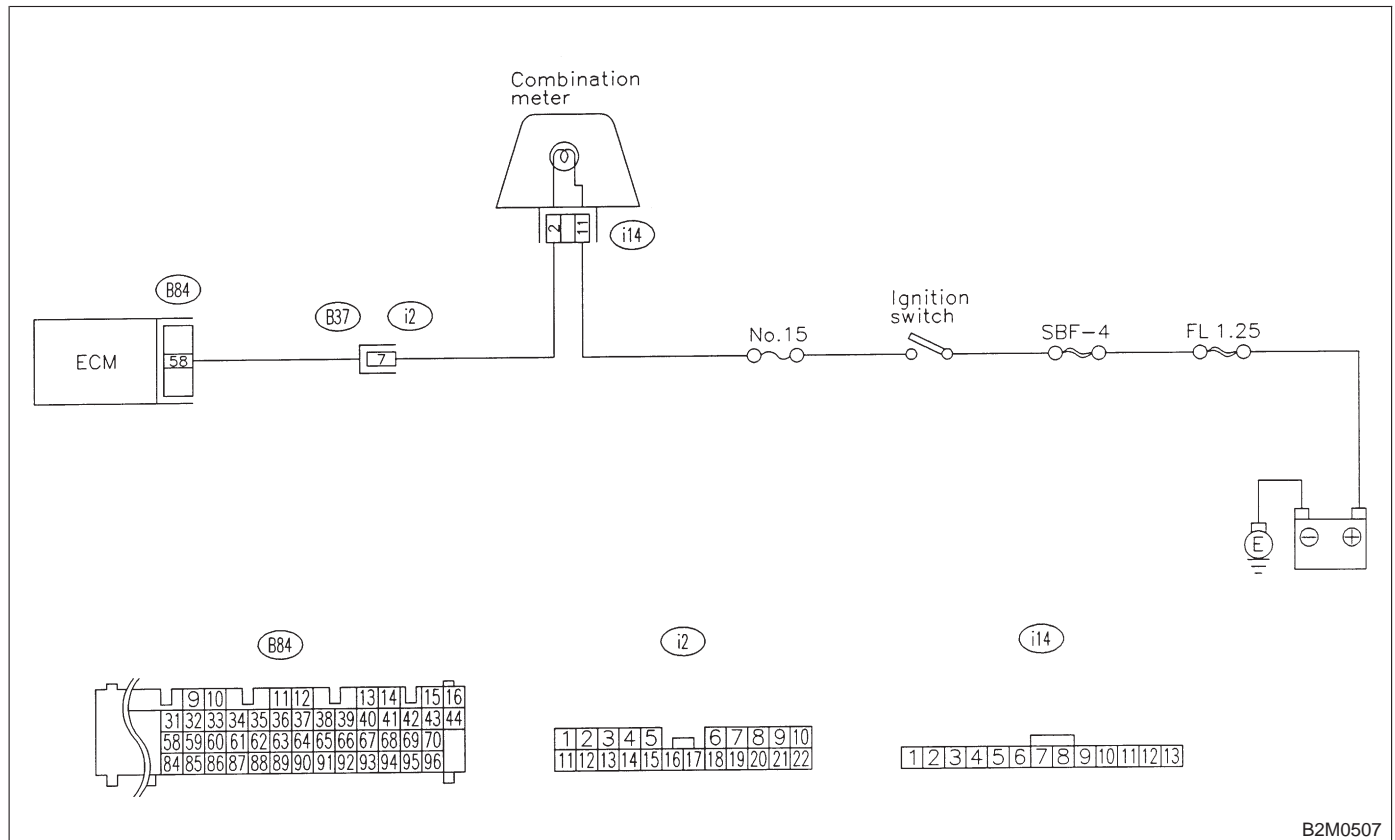

B2M0507

**8A1 : CHECK OUTPUT SIGNAL FROM ECM.**

- 1) Turn ignition switch to ON.
- 2) Measure voltage between ECM connector and chassis ground.

**Connector & terminal**  
**(B84) No. 58 (+) — Chassis ground (-):**

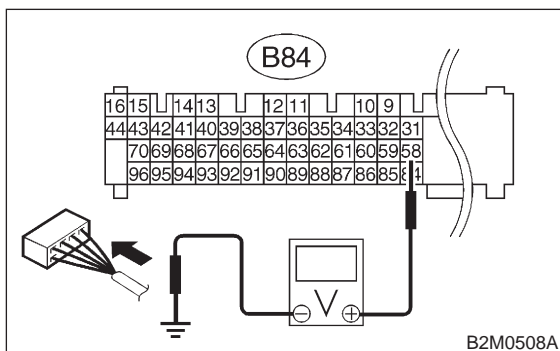

- CHECK** : Is the voltage less than 1 V?  
**YES** : Go to step 8A2.  
**NO** : Go to step 8A4.

**8A2 : CHECK POOR CONTACT.**

- CHECK** : Does the MIL come on when shaking or pulling ECM connector and harness?  
**YES** : Repair poor contact in ECM connector.  
**NO** : Go to step 8A3.

**8A3 : CHECK ECM CONNECTOR.**

- CHECK** : Is ECM connector correctly connected?  
**YES** : Replace ECM. <Ref. to 2-7 [W15A2].>  
**NO** : Repair connection of ECM connector.

**8A4 : CHECK HARNESS BETWEEN COMBINATION METER AND ECM CONNECTOR.**

- 1) Turn ignition switch to OFF.
- 2) Remove combination meter. <Ref. to 6-2 [W14A1].>
- 3) Disconnect connector from ECM and combination meter.
- 4) Measure resistance of harness between ECM and combination meter connector.

**Connector & terminal**  
**(B84) No. 58 — (i14) No. 2:**

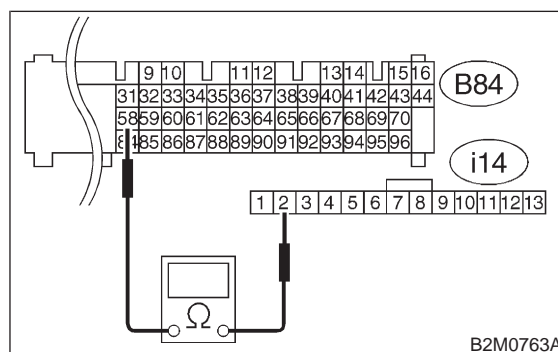

- CHECK** : Is resistance less than 1 Ω?  
**YES** : Go to step 8A5.  
**NO** : Repair harness and connector.

**NOTE:**

In this case, repair the following:

- Open circuit in harness between ECM and combination meter connector
- Poor contact in coupling connector (i2)

**8A5 : CHECK POOR CONTACT.**

Check poor contact in combination meter connector.  
 <Ref. to FOREWORD [T3C1].>

- CHECK** : Is there poor contact in combination meter connector?  
**YES** : Repair poor contact in combination meter connector.  
**NO** : Go to step 8A6.

## 2-7 [T8A6]

# ON-BOARD DIAGNOSTICS II SYSTEM

8. Diagnostics for CHECK ENGINE Malfunction Indicator Lamp (MIL) [2500 cc Model]

### 8A6 : CHECK HARNESS BETWEEN COMBINATION METER AND IGNITION SWITCH CONNECTOR.

- 1) Turn ignition switch to ON.
- 2) Measure voltage between combination meter connector and chassis ground.

#### Connector & terminal

(i14) No. 11 (+) — Chassis ground (-):

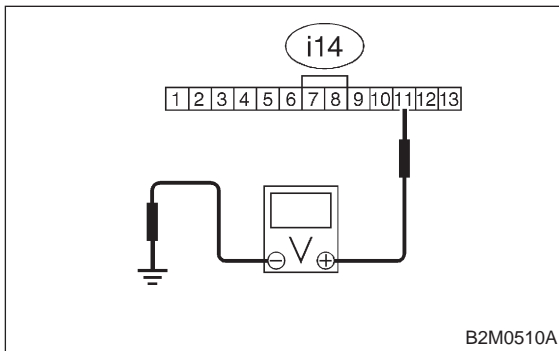

- CHECK** : *Is voltage more than 10 V?*
- YES** : Go to step **8A7**.
- NO** : Check the following and repair if necessary.

#### NOTE:

- Blown out fuse (No. 15).
- If replaced fuse (No. 15) is blown easily, check the harness for short circuit of harness between fuse (No. 15) and combination meter connector.
  - Open or short circuit in harness between fuse (No. 15) and combination meter connector
  - Open or short circuit in harness between fuse (No. 15) and ignition switch connector
  - Poor contact in ignition switch connector

### 8A7 : CHECK POOR CONTACT.

Check poor contact in combination meter connector.

<Ref. to FOREWORD [T3C1].>

- CHECK** : *Is there poor contact in combination meter connector?*
- YES** : Repair poor contact in combination meter connector.
- NO** : Replace bulb or combination meter.  
<Ref. to 6-2 [W1400].>

## ON-BOARD DIAGNOSTICS II SYSTEM

[T8A7] 2-7

8. Diagnostics for CHECK ENGINE Malfunction Indicator Lamp (MIL) [2500 cc Model]

---

**MEMO:**

**B: CHECK ENGINE MALFUNCTION INDICATOR LAMP (MIL) DOES NOT GO OFF.**

- **DIAGNOSIS:**
  - The CHECK ENGINE malfunction indicator lamp (MIL) circuit is shorted.
- **TROUBLE SYMPTOM:**
  - Although MIL comes on when engine runs, trouble code is not shown on Subaru Select Monitor or OBD-II general scan tool display.
- **WIRING DIAGRAM:**

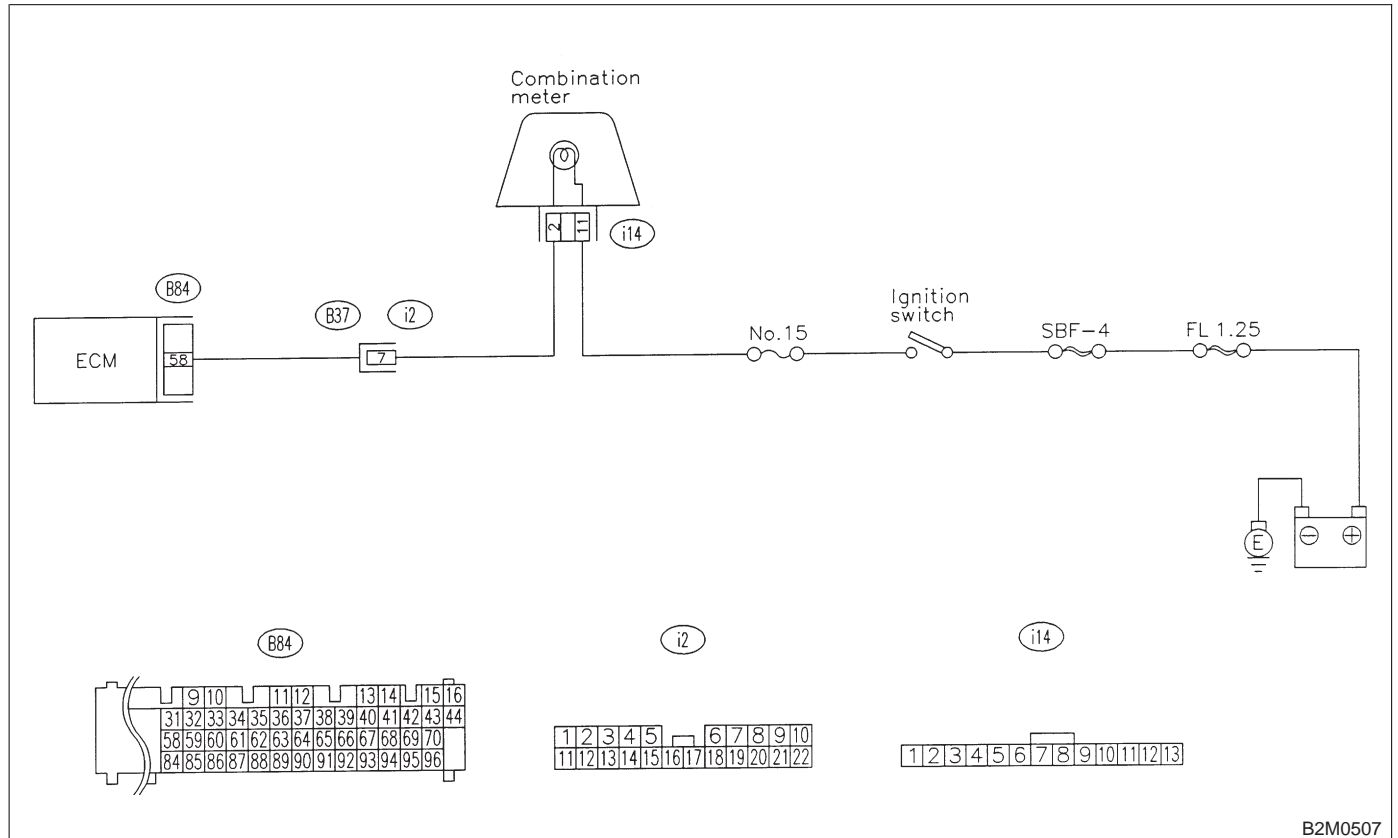

B2M0507

**8B1 : CHECK HARNESS BETWEEN COMBINATION METER AND ECM CONNECTOR.**

- 1) Turn ignition switch to OFF.
- 2) Disconnect connector from ECM.
- 3) Turn ignition switch to ON.

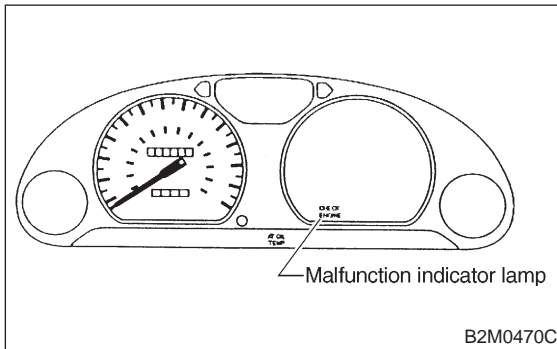

- CHECK** : **Does the MIL come on?**
- YES** : Repair ground short circuit in harness between combination meter and ECM connector.
- NO** : Replace ECM. <Ref. to 2-7 [W15A2].>

**C: CHECK ENGINE MALFUNCTION INDICATOR LAMP (MIL) DOES NOT BLINK AT A CYCLE OF 3 Hz.**

- **DIAGNOSIS:**
  - The CHECK ENGINE malfunction indicator lamp (MIL) circuit is open or shorted.
  - Test mode connector circuit is in open.
- **TROUBLE SYMPTOM:**
  - When inspection mode, MIL does not blink at a cycle of 3 Hz.
- **WIRING DIAGRAM:**

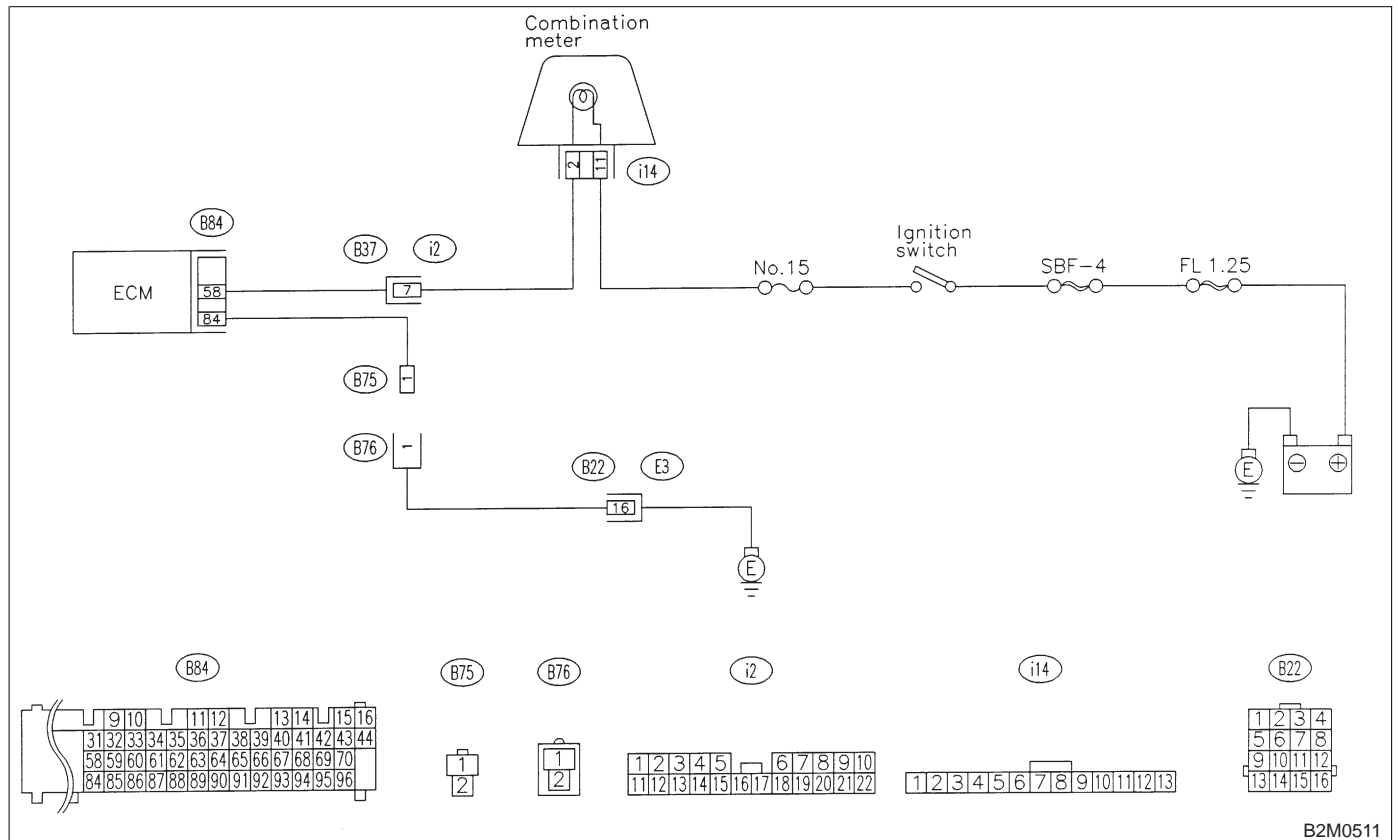

B2M0511

**8C1 : CHECK OPERATION OF CHECK ENGINE MALFUNCTION INDICATOR LAMP (MIL).**

- 1) Turn ignition switch to OFF.
- 2) Disconnect test mode connector.
- 3) Turn ignition switch to ON.

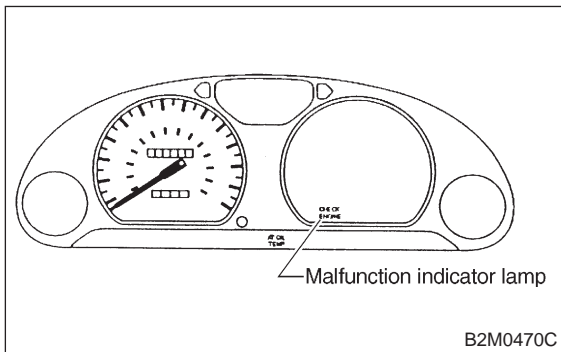

- CHECK** : Does the MIL come on?
- YES** : Go to step 8C2.
- NO** : Repair the MIL circuit. <Ref. to 2-7 [T8A0].>

**8C2 : CHECK OUTPUT SIGNAL FROM ECM.**

Measure voltage between test mode connector and chassis ground.

**Connector & terminal**  
(B75) No. 1 (+) — Chassis ground (-):

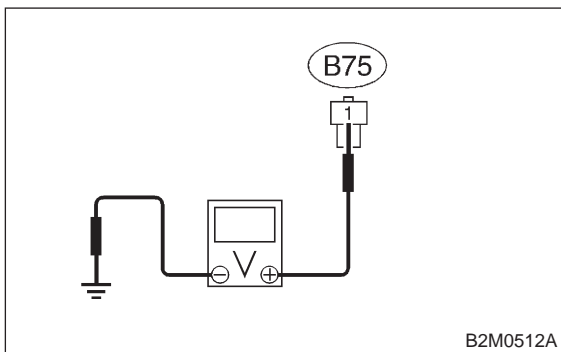

- CHECK** : Is voltage less than 1 V?
- YES** : Go to step 8C3.
- NO** : Go to step 8C5.

**8C3 : CHECK HARNESS BETWEEN ECM AND TEST MODE CONNECTOR.**

- 1) Turn ignition switch to OFF.
- 2) Disconnect connector from ECM.
- 3) Measure resistance of harness between ECM and test mode connector.

**Connector & terminal**  
(B84) No. 84 — (B75) No. 1:

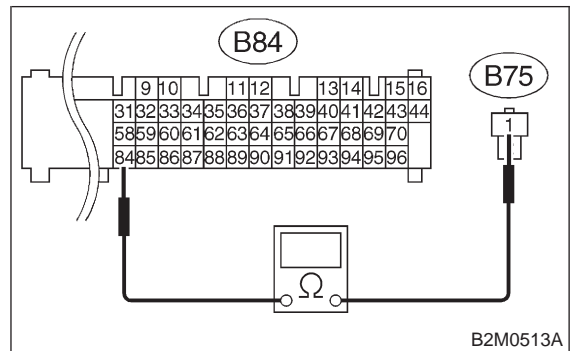

- CHECK** : Is resistance less than 1 Ω?
- YES** : Go to step 8C4.
- NO** : Repair open circuit in harness between ECM and test mode connector.

**8C4 : CHECK POOR CONTACT.**

Check poor contact in ECM connector.  
<Ref. to FOREWORD [T3C1].>

- CHECK** : Is there poor contact in ECM connector?
- YES** : Repair poor contact in ECM connector.
- NO** : Replace ECM. <Ref. to 2-7 [W15A2].>



**8C5 : CHECK GROUND CIRCUIT.**

- 1) Turn ignition switch to OFF.
- 2) Measure resistance of harness between test mode connector and chassis ground.

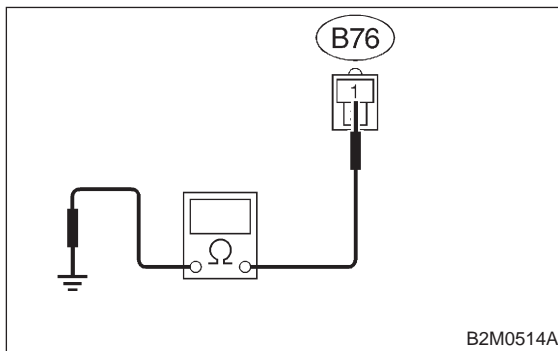
**Connector & terminal****(B76) No.1 — Chassis ground:****CHECK** : **Is resistance less than 5 Ω?****YES** : Repair poor contact in test mode connector.**NO** : Repair harness and connector.**NOTE:**

In this case, repair the following:

- Open circuit in harness between test mode and coupling connector (B22)
- Open circuit in harness between coupling connector (B22) and engine grounding terminal
- Poor contact in coupling connector (B22)

## ON-BOARD DIAGNOSTICS II SYSTEM

[T8C5] 2-7

8. Diagnostics for CHECK ENGINE Malfunction Indicator Lamp (MIL) [2500 cc Model]

---

**MEMO:**



**8D1 : CHECK HARNESS BETWEEN ECM CONNECTOR AND ENGINE GROUNDING TERMINAL.**

- 1) Turn ignition switch to OFF.
- 2) Disconnect connector from ECM.
- 3) Measure resistance of harness between ECM connector and chassis ground.

**Connector & terminal**

**(B84) No. 84 — Chassis ground:**

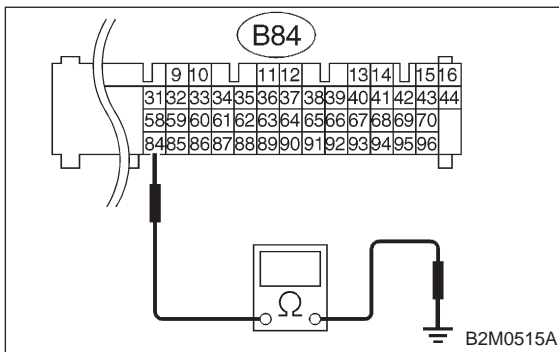

- CHECK** : **Is resistance less than 5 Ω?**
- YES** : Repair short circuit in harness between ECM and test mode connector.
- NO** : Replace ECM. <Ref. to 2-7 [W15A2].>

## **2-7 [T8D1]**

# **ON-BOARD DIAGNOSTICS II SYSTEM**

8. Diagnostics for CHECK ENGINE Malfunction Indicator Lamp (MIL) [2500 cc Model]

---

**MEMO:**