

9. Diagnostics for Engine Starting Failure [2200 cc Model]

A: BASIC DIAGNOSTICS CHART

1. Inspection of starter motor circuit. <Ref. to 2-7 [T9B0].>	↓
2. Inspection of ECM power supply and ground line. <Ref. to 2-7 [T9C0].>	↓
3. Inspection of ignition control system. <Ref. to 2-7 [T9D0].>	↓
4. Inspection of fuel pump circuit. <Ref. to 2-7 [T9E0].>	↓
5. Inspection of fuel injector circuit. <Ref. to 2-7 [T9F0].>	↓
6. Inspection of crankshaft position sensor circuit. <Ref. to 2-7 [T9G0].> or <Ref. to 2-7 [T9H0].>	↓
7. Inspection of camshaft position sensor circuit. <Ref. to 2-7 [T9I0].>	↓
8. Inspection using Subaru Select Monitor or OBD-II general scan tool (California spec. LHD vehicles: <Ref. to 2-7 [T12A0].>, California spec. RHD vehicles: <Ref. to 2-7 [T13A0].>, except California spec. LHD vehicles: <Ref. to 2-7 [T14A0].> and except California spec. RHD vehicles: <Ref. to 2-7 [T15A0].> or inspection using "11. General Diagnostics Table". <Ref. to 2-7 [T1100].>	

B: STARTER MOTOR CIRCUIT

CAUTION:

After repair or replacement of faulty parts, conduct CLEAR MEMORY MODE <Ref. to 2-7 [T3D0].> and INSPECTION MODE <Ref. to 2-7 [T3E0].>

● **WIRING DIAGRAM:**

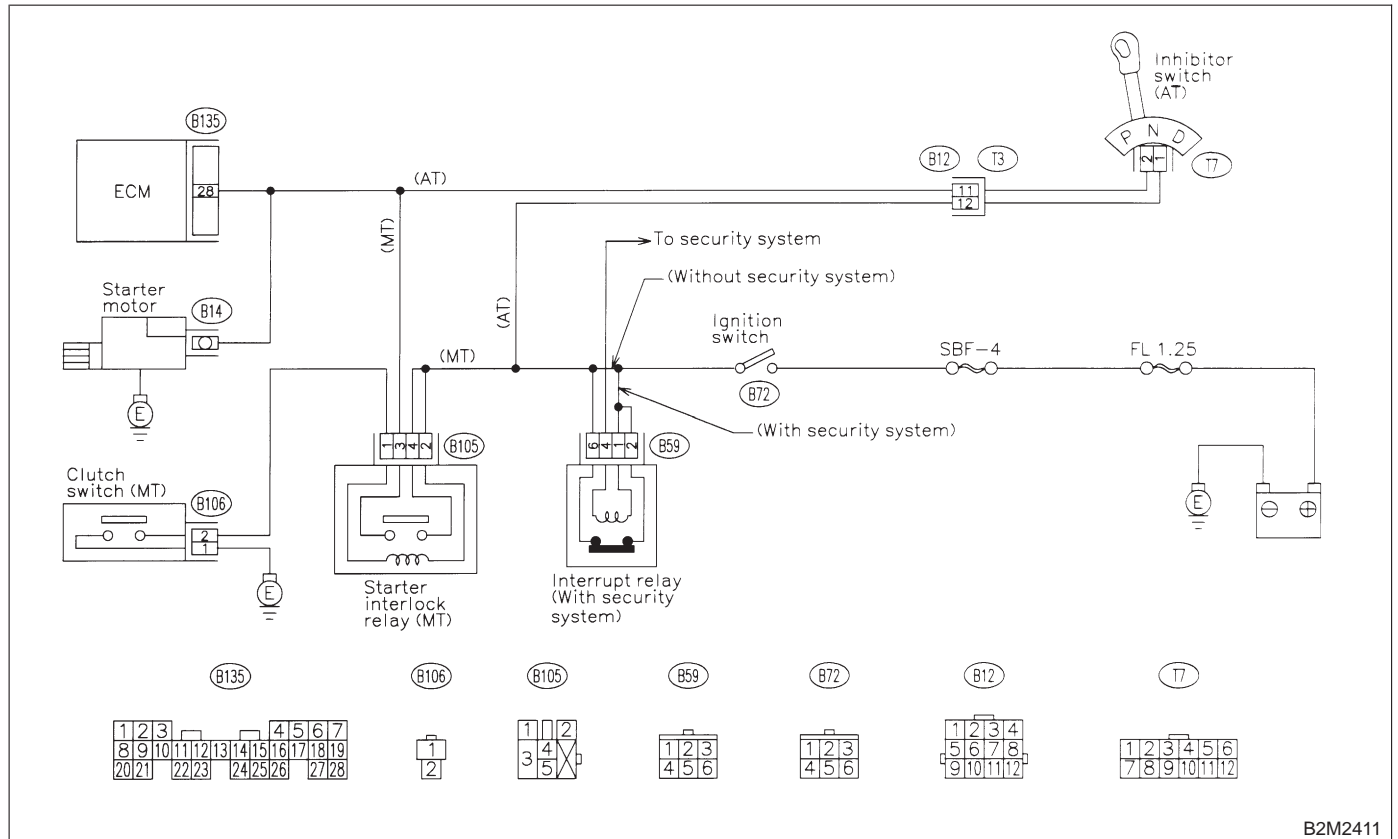

B2M2411

9B1 : CHECK VEHICLE TYPE.

- CHECK** : *Is the vehicle equipped with security system?*
- YES** : Check keyless/security system circuit. <Ref. to 6-2c [T6E0].>
- NO** : Go to step **9B2**.

9B2 : CHECK INPUT SIGNAL FOR STARTER MOTOR.

1) Turn ignition switch to OFF.

2) Disconnect connector from starter motor.

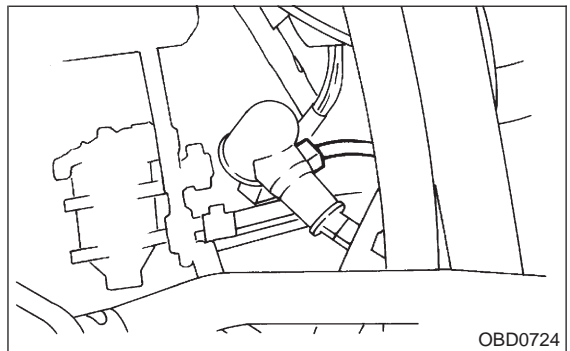

OBD0724

3) Turn ignition switch to ST.

4) Measure power supply voltage between starter motor connector terminal and engine ground.

Connector & terminal

(B14) No. 1 (+) — Engine ground (-):

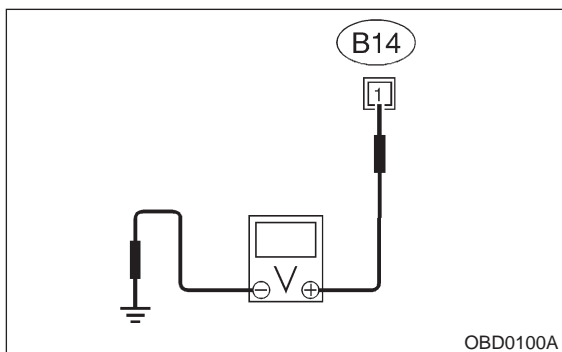

NOTE:

- On AT vehicles, place the selector lever in the “P” or “N” position.
- On MT vehicles, depress the clutch pedal.

CHECK : **Is the voltage more than 10 V?**

YES : Go to step **9B3**.

NO : Go to step **9B4**.

9B3 : CHECK GROUND CIRCUIT OF STARTER MOTOR.

- 1) Turn ignition switch to OFF.
- 2) Disconnect terminal from starter motor.



3) Measure resistance of ground cable between ground cable terminal and engine ground.

CHECK : **Is resistance less than 5 Ω?**

YES : Check starter motor. <Ref. to 6-1 [K100].>

NO : Repair open circuit of ground cable.

9B4 : CHECK HARNESS BETWEEN BATTERY AND IGNITION SWITCH CONNECTOR.

- 1) Turn ignition switch to OFF.
- 2) Remove SBF No. 4 from main fuse box.
- 3) Measure resistance of fuse.

CHECK : **Is resistance less than 1 Ω?**

YES : Replace SBF No. 4.

NOTE:

● LHD model: <Ref. to 6-3 [D6A1].>

● RHD model: <Ref. to 6-3 [D6A2].>

NO : Go to step **9B5**.

9B5 : CHECK HARNESS BETWEEN BATTERY AND IGNITION SWITCH CONNECTOR.

- 1) Install SBF No. 4 to main fuse box.
- 2) Turn ignition switch to ON.
- 3) Measure power supply voltage between ignition switch connector and chassis ground.

Connector & terminal

(B72) No. 1 (+) — Chassis ground (-):

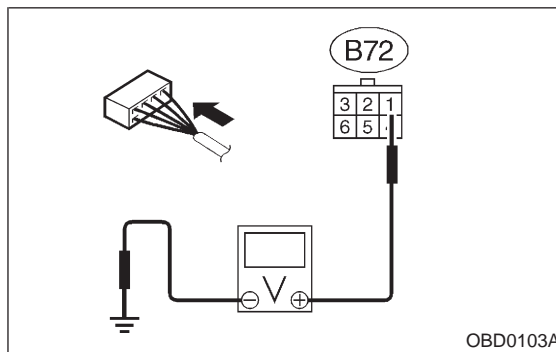

CHECK : **Is the voltage more than 10 V?**

YES : Go to step **9B6**.

NO : Repair open circuit in harness between ignition switch and SBF No. 4 connector.

9B6 : CHECK TRANSMISSION TYPE.

CHECK : **Is transmission type AT?**

YES : Go to step **9B7**.

NO : Go to step **9B11**.

9B7 : CHECK INHIBITOR SWITCH CIRCUIT.

- 1) Turn ignition switch to OFF.
- 2) Place the selector lever in the "P" or "N" position.
- 3) Measure resistance between transmission harness connector receptacle's terminals.

Connector & terminal
(T3) No. 11 — No. 12:

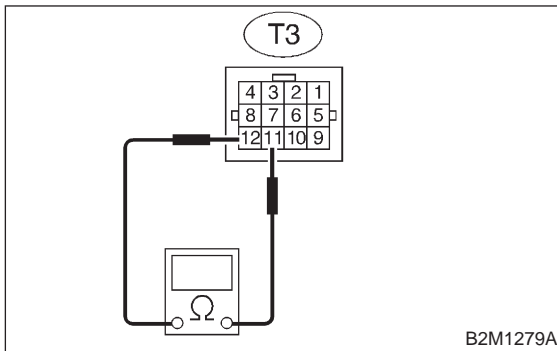

- CHECK** : Is the resistance less than 1 Ω?
- YES** : Repair open circuit in harness between starter motor and ignition switch connector.
- NO** : Go to step 9B8.

9B8 : CHECK TRANSMISSION HARNESS.

- 1) Disconnect connector from inhibitor switch.
- 2) Measure resistance of harness between transmission harness and inhibitor switch connector.

Connector & terminal
(T3) No. 11 — (T7) No. 2:

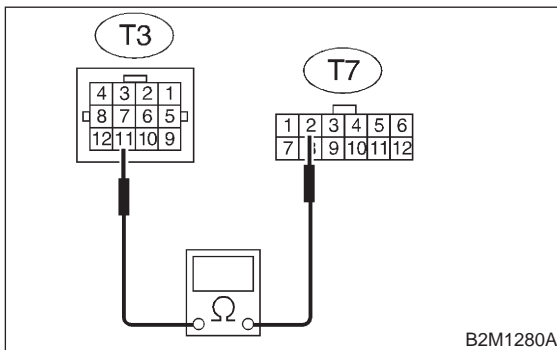

- CHECK** : Is the resistance less than 1 Ω?
- YES** : Go to step 9B9.
- NO** : Repair open circuit in harness between transmission harness and inhibitor switch connector.

9B9 : CHECK TRANSMISSION HARNESS.

Measure resistance of harness between transmission harness and inhibitor switch connector.

Connector & terminal
(T3) No. 12 — (T7) No. 1:

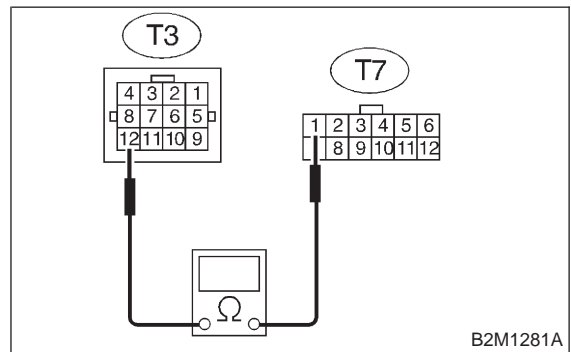

- CHECK** : Is the resistance less than 1 Ω?
- YES** : Go to step 9B10.
- NO** : Repair open circuit in harness between transmission harness and inhibitor switch connector.

9B10 : CHECK POOR CONTACT.

Check poor contact in inhibitor switch connector.
 <Ref. to FOREWORD [T3C1].>

- CHECK** : Is there poor contact in inhibitor switch connector?
- YES** : Repair poor contact in inhibitor switch connector.
- NO** : Replace inhibitor switch. <Ref. to 3-2 [W2C0].>

9B11 : CHECK STARTER INTERLOCK CIRCUIT.

- 1) Turn ignition switch to "ST".
- 2) Measure voltage between clutch switch connector and chassis ground.

Connector & terminal
(B106) No. 2 (+) — Chassis ground (-):

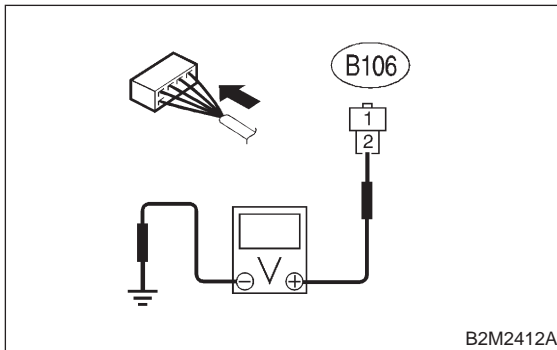

- CHECK** : **Is the voltage more than 10 V?**
- YES** : Replace starter interlock relay. <Ref. to 6-3 [D8D0].>
- NO** : Go to step **9B12**.

9B12 : CHECK STARTER INTERLOCK CIRCUIT.

- 1) Turn ignition switch to OFF.
- 2) Measure resistance between clutch switch connector terminals while depressing the clutch pedal.

Connector & terminal
(B106) No. 1 — No. 2:

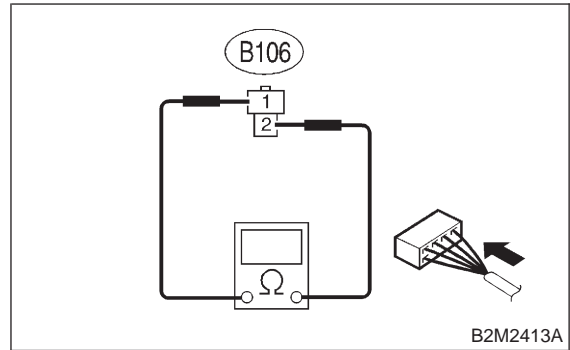

- CHECK** : **Is the resistance less than 10 Ω?**
- YES** : Repair open circuit in harness between starter motor and ignition switch connector.
- NO** : Replace clutch switch. <Ref. to 4-5 [C1A0].>

C: CONTROL MODULE POWER SUPPLY AND GROUND LINE

CAUTION:

After repair or replacement of faulty parts, conduct CLEAR MEMORY MODE <Ref. to 2-7 [T3D0].> and INSPECTION MODE <Ref. to 2-7 [T3E0].>

● **WIRING DIAGRAM:**

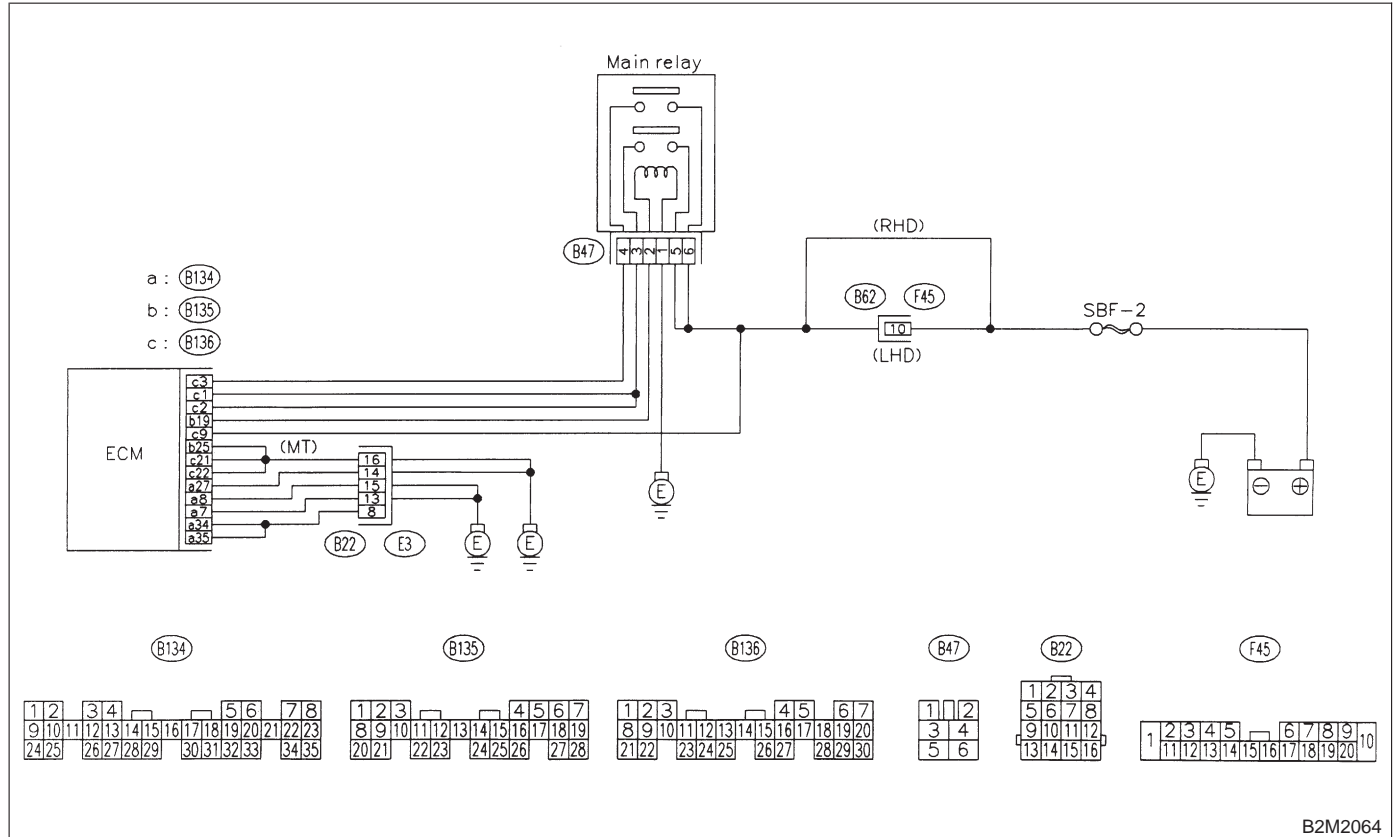

9C1 : CHECK MAIN RELAY.

- 1) Turn the ignition switch to OFF.
- 2) Remove main relay.
- 3) Connect battery to main relay terminals No. 1 and No. 2.

4) Measure resistance between main relay terminals.

Terminals
No. 3 — No. 5:

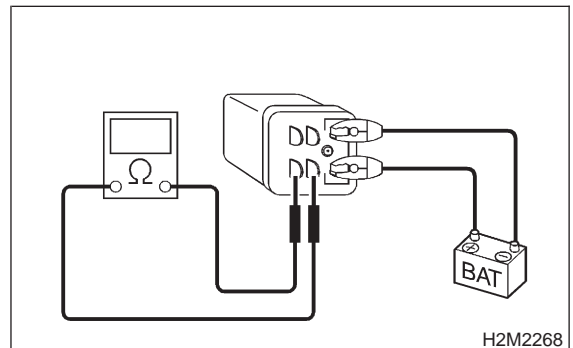

- CHECK** : Is the resistance less than 10 Ω?
- YES** : Go to step 9C2.
- NO** : Replace main relay. <Ref. to 2-7 [W16A0].>

9C2 : CHECK MAIN RELAY.

Measure resistance between main relay terminals.

Terminals

No. 4 — No. 6:

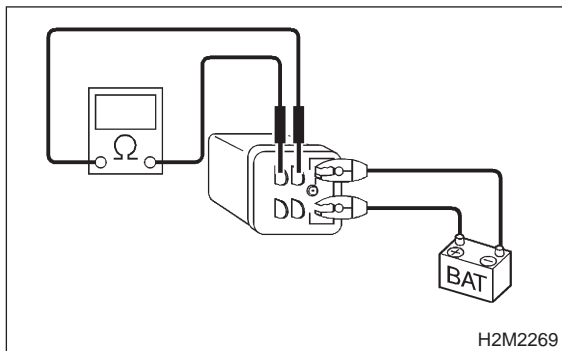

CHECK : Is the resistance less than 10 Ω?

YES : Go to step 9C3.

NO : Replace main relay. <Ref. to 2-7 [W16A0].>

9C3 : CHECK POWER SUPPLY CIRCUIT OF ECM.

- 1) Install main relay.
- 2) Disconnect connectors from ECM.
- 3) Turn ignition switch to ON.
- 4) Measure power supply voltage between ECM connectors.

Connector & terminal

(B136) No. 8 (+) — (B134) No. 1 (-):

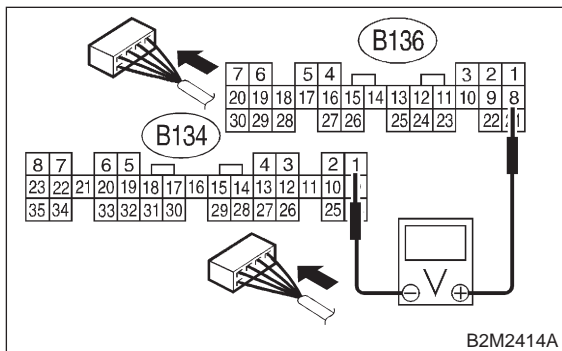

CHECK : Is the voltage more than 10 V?

YES : Go to step 9C4.

NO : Repair open or ground short circuit in harness of power supply circuit.

9C4 : CHECK POWER SUPPLY CIRCUIT OF ECM.

Measure power supply voltage between ECM connector terminals.

Connector & terminal

(B136) No. 2 (+) — (B134) No. 8 (-):

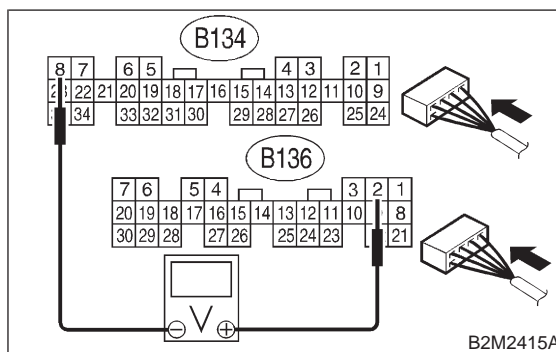

CHECK : Is the voltage more than 10 V?

YES : Go to step 9C5.

NO : Repair open or ground short circuit in harness of power supply circuit.

9C5 : CHECK POWER SUPPLY CIRCUIT OF ECM.

Measure power supply voltage between ECM connectors.

Connector & terminal

(B136) No. 9 (+) — (B134) No. 8 (-):

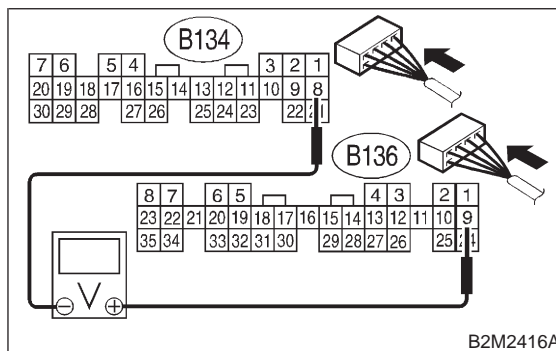

CHECK : Is the voltage more than 10 V?

YES : Go to step 9C6.

NO : Repair open or ground short circuit in harness of power supply circuit.

9C6 : CHECK GROUND CIRCUIT OF ECM.

- 1) Turn ignition switch to OFF.
- 2) Measure resistance of harness connector between ECM and chassis ground.

Connector & terminal
(B134) No. 7 — Chassis ground:

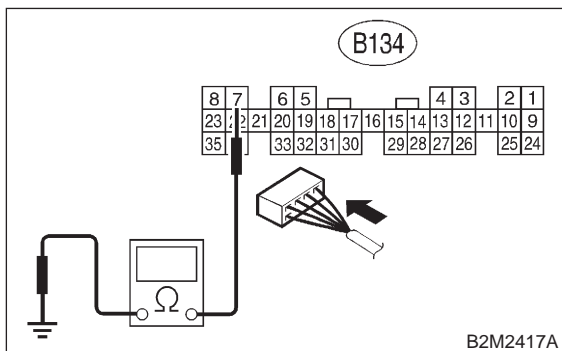

- CHECK** : Is the resistance less than 5 Ω?
- YES** : Go to step 9C7.
- NO** : Repair open circuit in harness between ECM connector and engine grounding terminal.

9C7 : CHECK GROUND CIRCUIT OF ECM.

Measure resistance of harness between ECM and chassis ground.

Connector & terminal
(B134) No. 8 — Chassis ground:

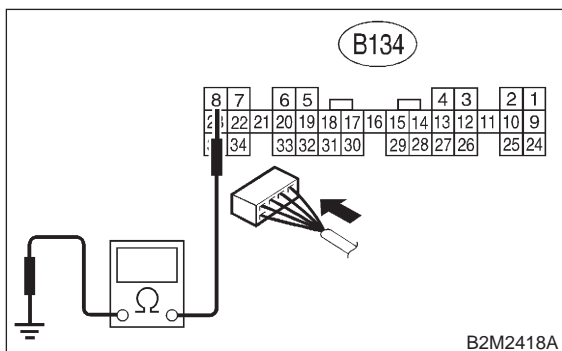

- CHECK** : Is the resistance less than 5 Ω?
- YES** : Go to step 9C8.
- NO** : Repair open circuit in harness between ECM connector and engine grounding terminal.

9C8 : CHECK GROUND CIRCUIT OF ECM.

Measure resistance of harness between ECM and chassis ground.

Connector & terminal
(B134) No. 27 — Chassis ground:

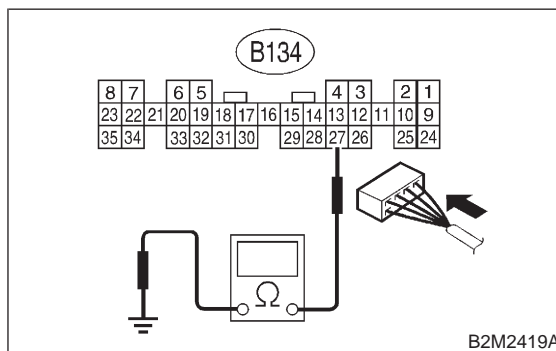

- CHECK** : Is the resistance less than 5 Ω?
- YES** : Go to step 9C9.
- NO** : Repair open circuit in harness between ECM connector and engine grounding terminal.

9C9 : CHECK GROUND CIRCUIT OF ECM.

Measure resistance of harness between ECM and chassis ground.

Connector & terminal
(B134) No. 34 — Chassis ground:

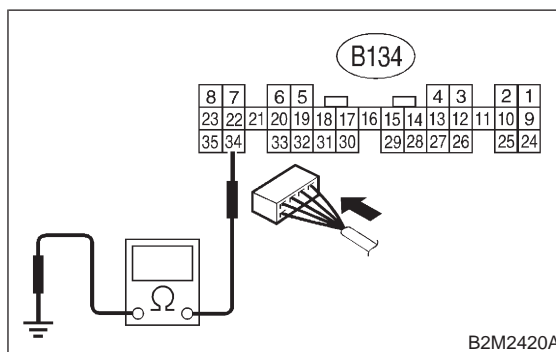

- CHECK** : Is the resistance less than 5 Ω?
- YES** : Go to step 9C10.
- NO** : Repair open circuit in harness between ECM connector and engine grounding terminal.

9C10 : CHECK GROUND CIRCUIT OF ECM.

Measure resistance of harness between ECM and chassis ground.

Connector & terminal
(B134) No. 35 — Chassis ground:

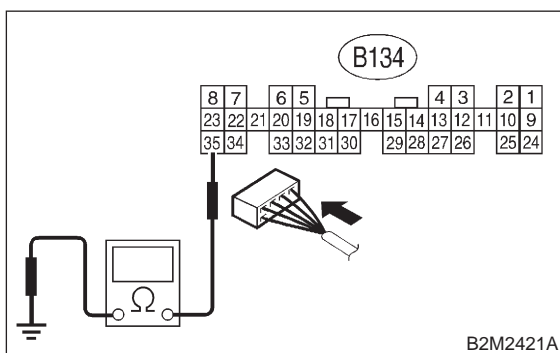

- CHECK** : Is the resistance less than 5 Ω?
- YES** : Go to step 9C11.
- NO** : Repair open circuit in harness between ECM connector and engine grounding terminal.

9C11 : CHECK GROUND CIRCUIT OF ECM.

Measure resistance of harness between ECM and chassis ground.

Connector & terminal
(B136) No. 21 — Chassis ground:

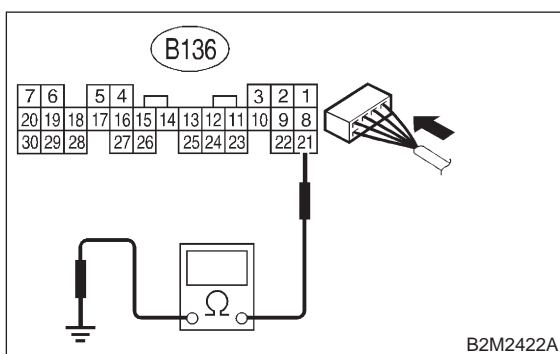

- CHECK** : Is the resistance less than 5 Ω?
- YES** : Go to step 9C12.
- NO** : Repair open circuit in harness between ECM connector and engine grounding terminal.

9C12 : CHECK GROUND CIRCUIT OF ECM.

Measure resistance of harness between ECM and chassis ground.

Connector & terminal
(B136) No. 22 — Chassis ground:

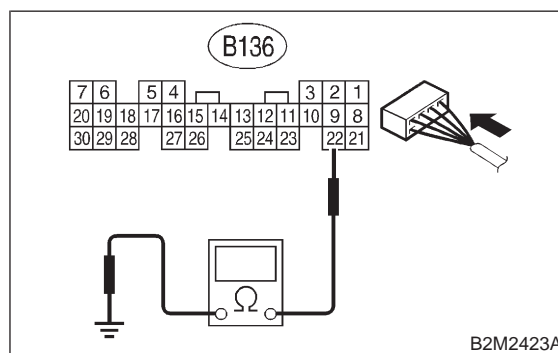

- CHECK** : Is the resistance less than 5 Ω?
- YES** : Go to step 9C13.
- NO** : Repair open circuit in harness between ECM connector and engine grounding terminal.

9C13 : CHECK TRANSMISSION TYPE.

- CHECK** : Is transmission type AT?
- YES** : Check ignition control system. <Ref. to 2-7 [T9D0].>
- NO** : Go to step 9C14.

9C14 : CHECK GROUND CIRCUIT OF ECM.

Measure resistance of harness between ECM and chassis ground.

Connector & terminal

(B135) No. 25 — Chassis ground:

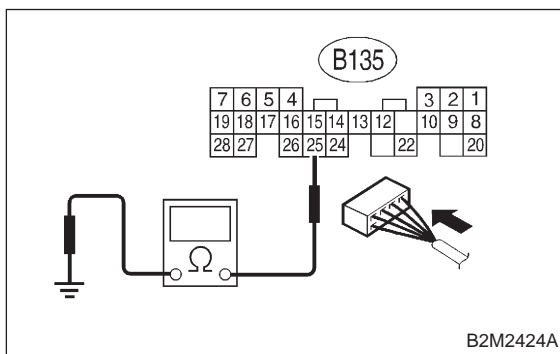

- CHECK** : **Is the resistance less than 5 Ω?**
- YES** : Check ignition control system. <Ref. to 2-7 [T9D0].>
- NO** : Repair open circuit in harness between ECM connector and engine grounding terminal.

MEMO:

D: IGNITION CONTROL SYSTEM

CAUTION:

After repair or replacement of faulty parts, conduct CLEAR MEMORY MODE <Ref. to 2-7 [T3D0].> and INSPECTION MODE <Ref. to 2-7 [T3E0].>

● **WIRING DIAGRAM:**

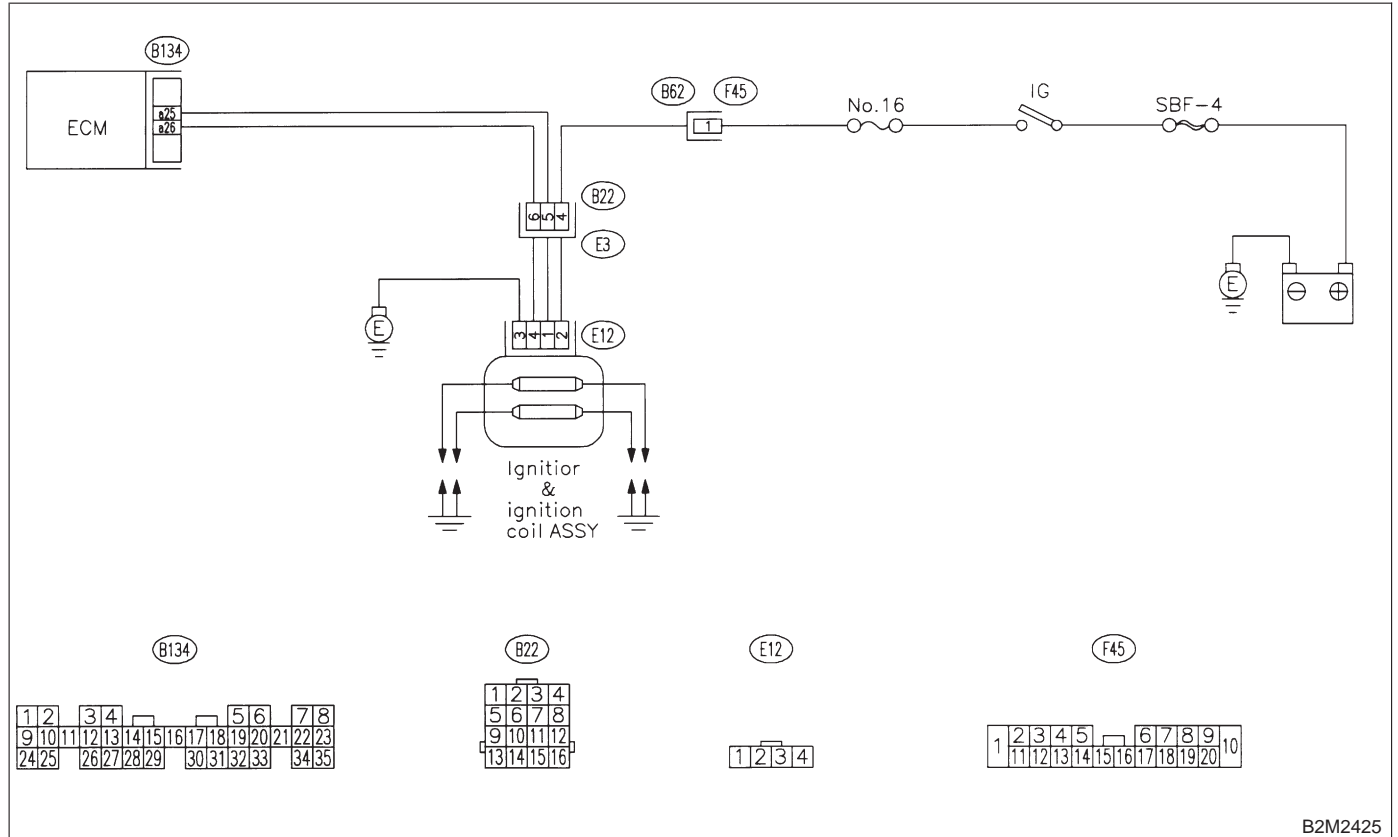

B2M2425

9D1 : CHECK IGNITION SYSTEM FOR SPARKS.

- 1) Remove plug cord cap from each spark plug.
- 2) Install new spark plug on plug cord cap.

CAUTION:

Do not remove spark plug from engine.

- 3) Contact spark plug's thread portion on engine.
- 4) While opening throttle valve fully, crank engine to check that spark occurs at each cylinder.

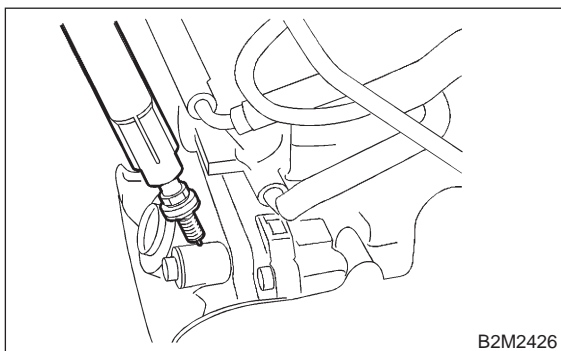

- CHECK** : **Does spark occur at each cylinder?**
- YES** : Check fuel pump system. <Ref. to 2-7 [T9E0].>
- NO** : Go to step **9D2**.

9D2 : CHECK POWER SUPPLY CIRCUIT FOR IGNITION COIL & IGNITOR ASSEMBLY.

- 1) Turn ignition switch to OFF.
- 2) Disconnect connector from ignition coil & ignitor assembly.
- 3) Turn ignition switch to ON.
- 4) Measure power supply voltage between ignition coil & ignitor assembly connector and engine ground.

Connector & terminal

(E12) No. 2 (+) — Engine ground (-):

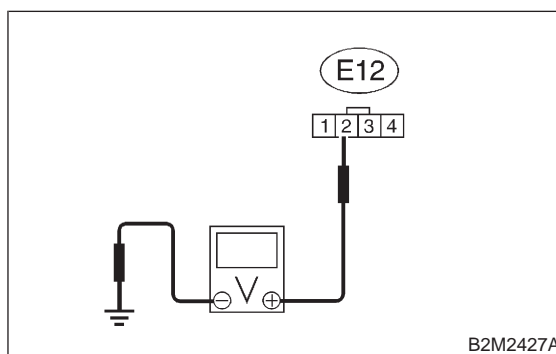

- CHECK** : **Is the voltage more than 10 V?**
- YES** : Go to step **9D3**.
- NO** : Repair harness and connector.

NOTE:

In this case, repair the following:

- Open circuit in harness between ignition coil & ignitor assembly, and ignition switch connector
- Poor contact in coupling connectors (B22 and F45)

9D3 : CHECK HARNESS OF IGNITION COIL & IGNITOR ASSEMBLY GROUND CIRCUIT.

- 1) Turn ignition switch to OFF.
- 2) Measure resistance between ignition coil & ignitor assembly connector and engine ground.

Connector & terminal
(E12) No. 3 — Engine ground:

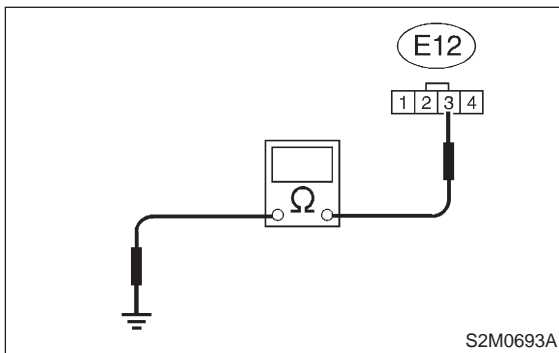

- CHECK** : Is the resistance between less than 5 Ω ?
- YES** : Go to step 9D4.
- NO** : Repair harness and connector.

NOTE:

In this case, repair the following:

- Open circuit in harness between ignition coil & ignitor assembly connector and engine grounding terminal

9D4 : CHECK IGNITION COIL & IGNITOR ASSEMBLY.

- 1) Remove spark plug cords.
- 2) Measure resistance between spark plug cord contact portions to check secondary coil.

Terminals

No. 1 — No. 2:

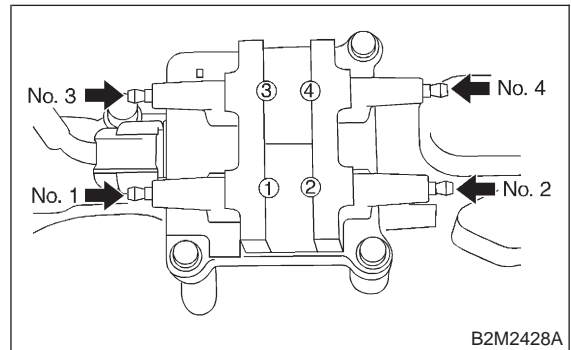

- CHECK** : Is the resistance between 10 and 15 $k\Omega$?
- YES** : Go to step 9D5.
- NO** : Replace ignition coil & ignitor assembly. <Ref. to 6-1 [W4A0].>

9D5 : CHECK IGNITION COIL & IGNITOR ASSEMBLY.

Measure resistance between spark plug cord contact portions to check secondary coil.

Terminals

No. 3 — No. 4:

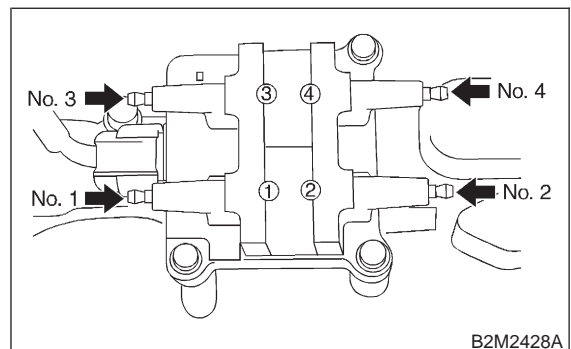

- CHECK** : Is the resistance between 10 and 15 $k\Omega$?
- YES** : Go to step 9D6.
- NO** : Replace ignition coil & ignitor assembly. <Ref. to 6-1 [W4A0].>

9D6 : CHECK INPUT SIGNAL FOR IGNITION COIL & IGNITOR ASSEMBLY.

- 1) Connect connector to ignition coil & ignitor assembly.
- 2) Check if voltage varies synchronously with engine speed when cranking, while monitoring voltage between ignition coil & ignitor assembly connector and engine ground.

Connector & terminal

(E12) No. 1 (+) — Engine ground (-):

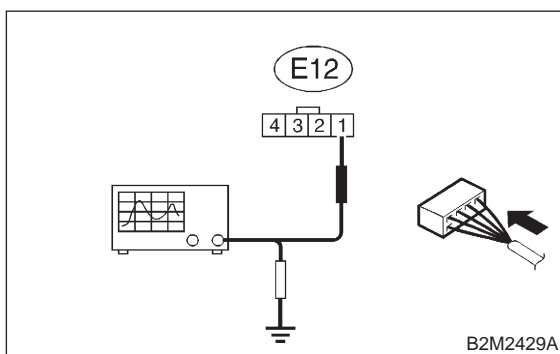

- CHECK** : Is the voltage more than 10 V?
- YES** : Go to step 9D7.
- NO** : Replace ignition coil & ignitor assembly.
<Ref. to 6-1 [W4A0].>

9D7 : CHECK INPUT SIGNAL FOR IGNITION COIL & IGNITOR ASSEMBLY.

Check if voltage varies synchronously with engine speed when cranking, while monitoring voltage between ignition coil & ignitor assembly connector and engine ground.

Connector & terminal

(E12) No. 4 (+) — Engine ground (-):

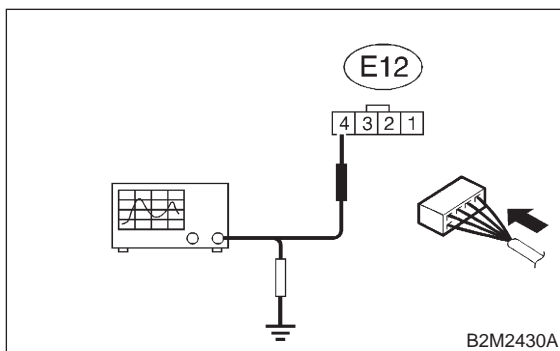

- CHECK** : Is the voltage more than 10 V?
- YES** : Go to step 9D8.
- NO** : Replace ignition coil & ignitor assembly.
<Ref. to 6-1 [W4A0].>

9D8 : CHECK HARNESS BETWEEN ECM AND IGNITION COIL & IGNITOR ASSEMBLY CONNECTOR.

- 1) Turn ignition switch to OFF.
- 2) Disconnect connector from ECM.
- 3) Disconnect connector from ignition coil & ignitor assembly.
- 4) Measure resistance of harness between ECM and ignition coil & ignitor assembly connector.

Connector & terminal

(B134) No. 25 — (E12) No. 1:

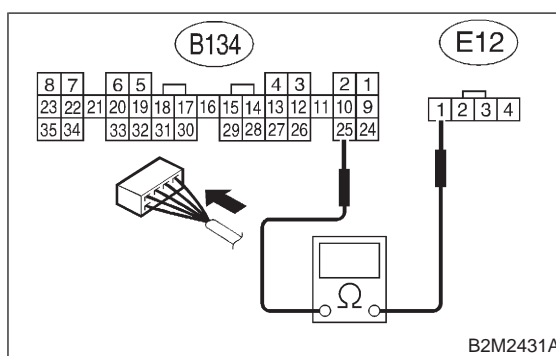

- CHECK** : Is the resistance less than 1 Ω?
- YES** : Go to step 9D9.
- NO** : Repair harness and connector.

NOTE:

In this case, repair the following:

- Open circuit in harness between ECM and ignition coil & ignitor assembly connector
- Poor contact in coupling connector (B22)

9D9 : CHECK HARNESS BETWEEN ECM AND IGNITION COIL & IGNITOR ASSEMBLY CONNECTOR.

Measure resistance of harness between ECM and ignition coil & ignitor assembly connector.

Connector & terminal
(B134) No. 26 — (E12) No. 4:

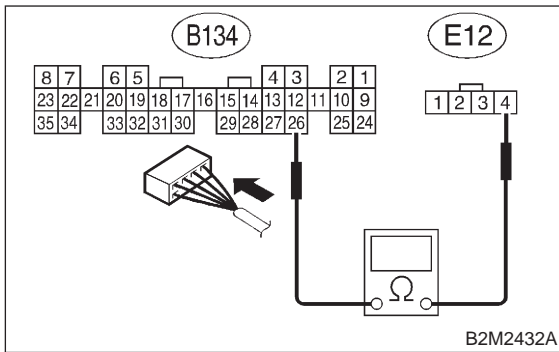

- CHECK** : Is the resistance less than 1 Ω?
- YES** : Go to step 9D10.
- NO** : Repair harness and connector.

NOTE:

In this case, repair the following:

- Open circuit in harness between ECM and ignition coil & ignitor assembly connector
- Poor contact in coupling connector (B22)

9D10 : CHECK HARNESS BETWEEN ECM AND IGNITION COIL & IGNITOR ASSEMBLY CONNECTOR.

Measure resistance of harness between ECM and engine ground.

Connector & terminal:
(B134) No. 25 — Engine ground:

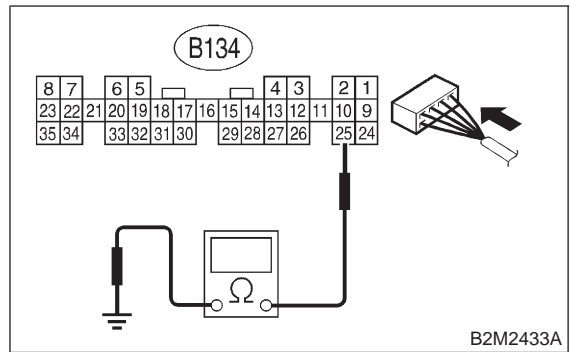

- CHECK** : Is the resistance more than 1 MΩ?
- YES** : Go to step 9D11.
- NO** : Repair ground short circuit in harness between ECM and ignition coil & ignitor assembly connector.

9D11 : CHECK HARNESS BETWEEN ECM AND IGNITION COIL & IGNITOR ASSEMBLY CONNECTOR.

Measure resistance of harness between ECM and engine ground.

Connector & terminal
(B134) No. 26 — Engine ground:

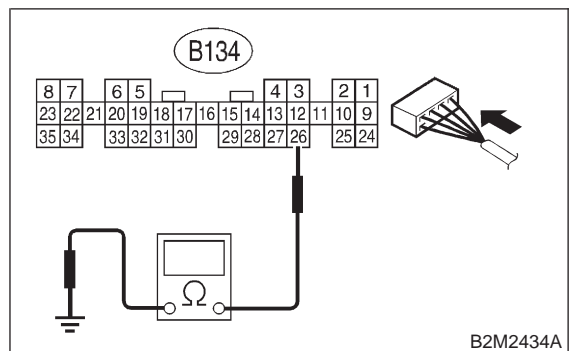

- CHECK** : Is the resistance more than 1 MΩ?
- YES** : Go to step 9D12.
- NO** : Repair ground short circuit in harness between ECM and ignition coil & ignitor assembly connector.

9D12 : CHECK POOR CONTACT.

Check poor contact in ECM connector. <Ref. to FOREWORD [T3C1].>

- CHECK** : *Is there poor contact in ECM connector?*
- YES** : Repair poor contact in ECM connector.
- NO** : Check fuel pump circuit. <Ref. to 2-7 [T9E0].>

E: FUEL PUMP CIRCUIT

CAUTION:

After repair or replacement of faulty parts, conduct CLEAR MEMORY MODE <Ref. to 2-7 [T3D0]> and INSPECTION MODE <Ref. to 2-7 [T3E0]>.

● **WIRING DIAGRAM:**

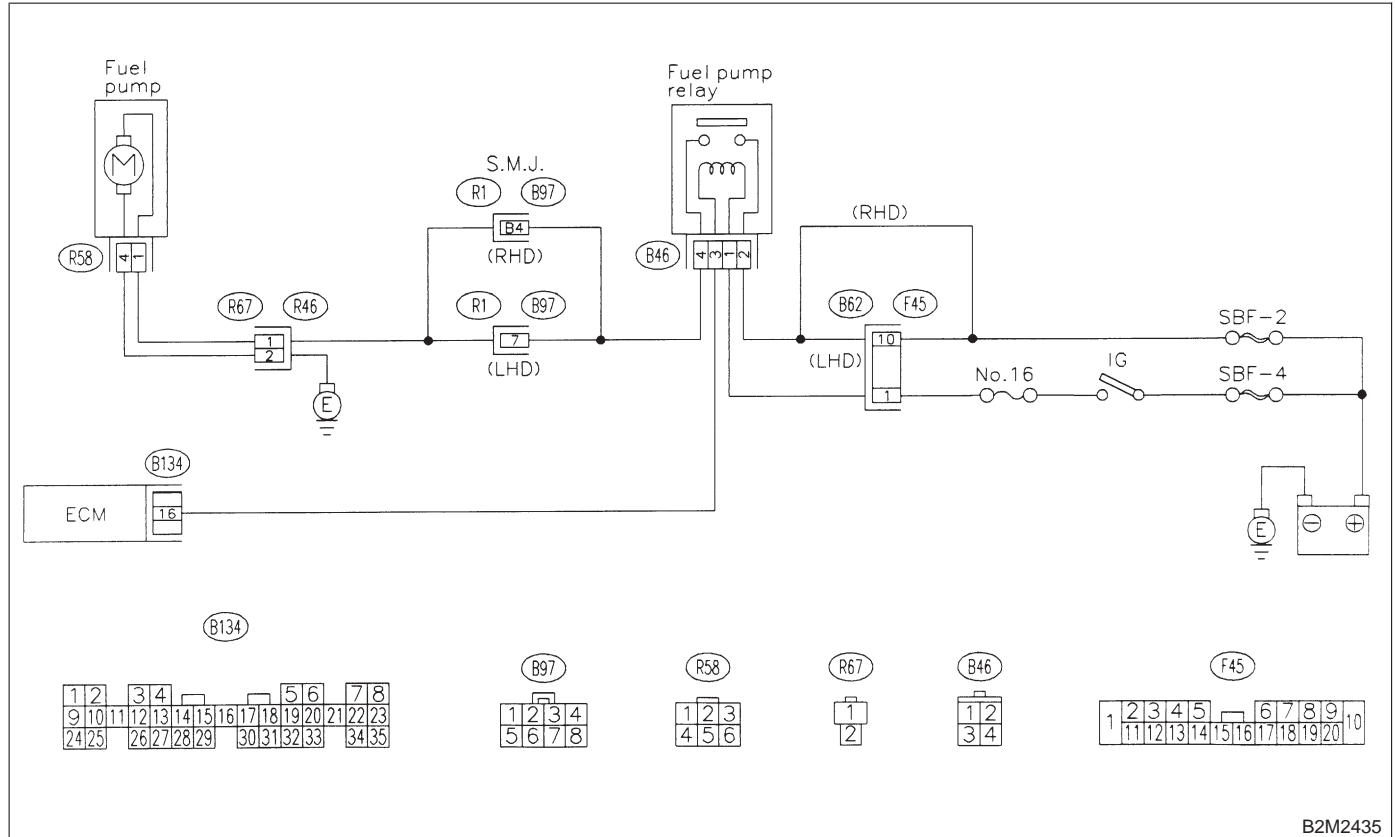

B2M2435

9E1 : CHECK OPERATING SOUND OF FUEL PUMP.

Make sure that fuel pump is in operation for two seconds when turning ignition switch to ON.

NOTE:

Fuel pump operation check can also be executed using Subaru Select Monitor (Function mode: FD01).

For the procedure, refer to "COMPULSORY VALVE OPERATION CHECK MODE". <Ref. to 2-7 [T3F0]>

- CHECK** : Does fuel pump produce operating sound?
- YES** : Check fuel injector circuit. <Ref. to 2-7 [T9F0]>
- NO** : Go to step **9E2**.

9E2 : CHECK GROUND CIRCUIT OF FUEL PUMP.

- 1) Turn ignition switch to OFF.
- 2) Remove fuel pump access hole lid located on the right rear of trunk compartment floor (Sedan) or luggage compartment floor (Wagon).

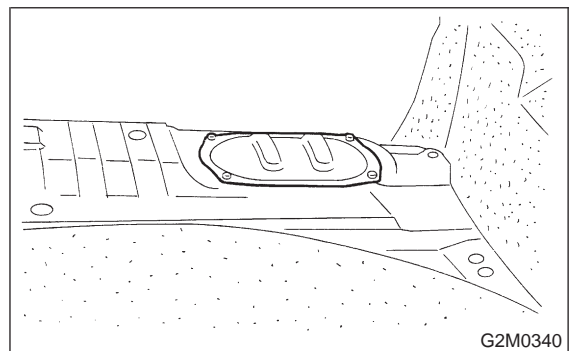

G2M0340

- 3) Disconnect connector from fuel pump.

4) Measure resistance of harness connector between fuel pump and chassis ground.

Connector & terminal

(R58) No. 4 — Chassis ground:

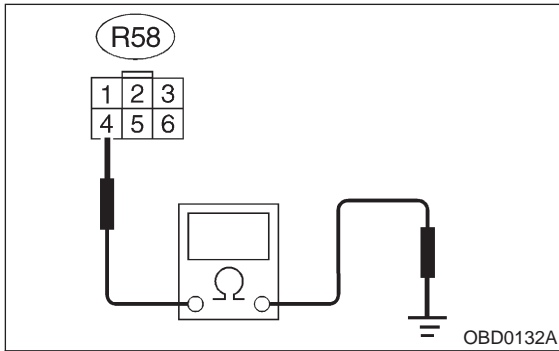

- CHECK** : Is the resistance less than 5 Ω?
- YES** : Go to step 9E3.
- NO** : Repair harness and connector.

NOTE:

In this case, repair the following:

- Open circuit in harness between fuel pump connector and chassis grounding terminal
- Poor contact in coupling connector (R67)

9E3 : CHECK POWER SUPPLY TO FUEL PUMP.

1) Turn ignition switch to ON.
 2) Measure voltage of power supply circuit between fuel pump connector and chassis ground.

Connector & terminal

(R58) No. 1 (+) — Chassis ground (-):

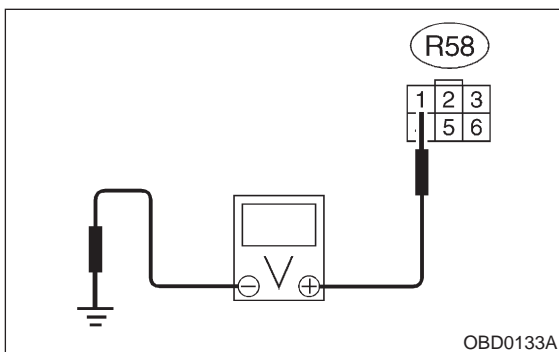

- CHECK** : Is the voltage more than 10 V?
- YES** : Replace fuel pump. <Ref. to 2-8 [W5A0].>
- NO** : Go to step 9E4.

9E4 : CHECK HARNESS BETWEEN FUEL PUMP AND FUEL PUMP RELAY CONNECTOR.

1) Turn ignition switch to OFF.
 2) Measure resistance of harness connector between fuel pump and fuel pump relay.

Connector & terminal

(R58) No. 1 — (B46) No. 4:

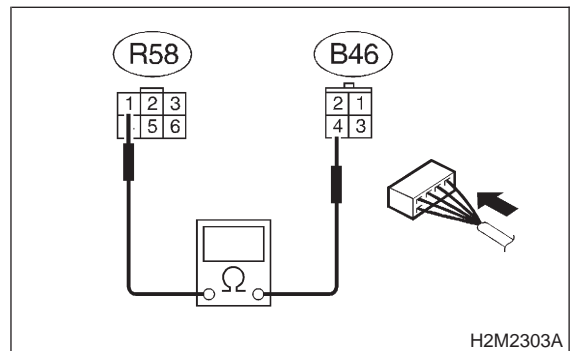

- CHECK** : Is the resistance less than 1 Ω?
- YES** : Go to step 9E5.
- NO** : Repair harness and connector.

NOTE:

In this case, repair the following:

- Open circuit in harness between fuel pump connector and chassis grounding terminal
- Poor contact in coupling connectors (R67 and B97)

9E5 : CHECK HARNESS BETWEEN FUEL PUMP AND FUEL PUMP RELAY CONNECTOR.

Measure resistance of harness between fuel pump and fuel pump relay connector.

Connector & terminal
(R58) No. 1 — Chassis ground:

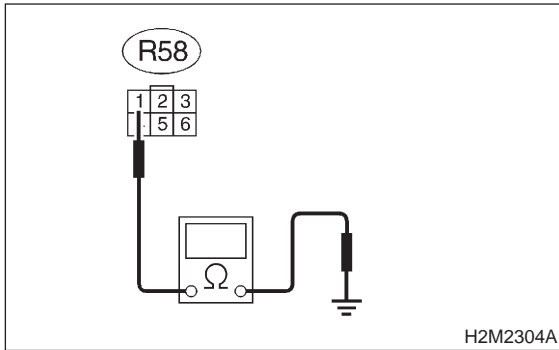

- CHECK** : **Is the resistance more than 1 MΩ?**
- YES** : Go to step **9E6**.
- NO** : Repair short circuit in harness between fuel pump and fuel pump relay connector.

9E6 : CHECK FUEL PUMP RELAY.

- 1) Disconnect connectors from fuel pump relay and main relay.
- 2) Remove fuel pump relay and main relay with bracket.
- 3) Connect battery to fuel pump relay connector terminals No. 1 and No. 3.
- 4) Measure resistance between connector terminals of fuel pump relay.

Terminals
No. 2 — No. 4:

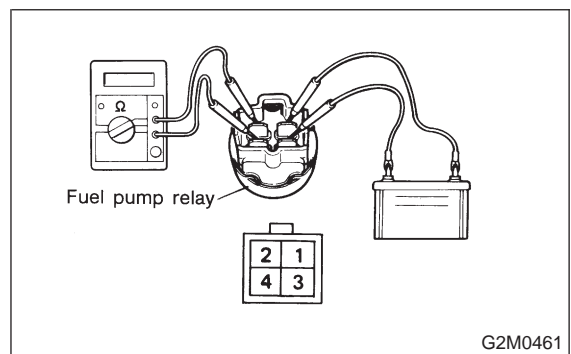

- CHECK** : **Is the resistance less than 10 Ω?**
- YES** : Go to step **9E7**.
- NO** : Replace fuel pump relay. <Ref. to 2-7 [W17A0].>

9E7 : CHECK HARNESS BETWEEN ECM AND FUEL PUMP RELAY CONNECTOR.

- 1) Disconnect connectors from ECM.
- 2) Measure resistance of harness between ECM and fuel pump relay connector.

Connector & terminal

(B134) No. 16 — (B46) No. 3:

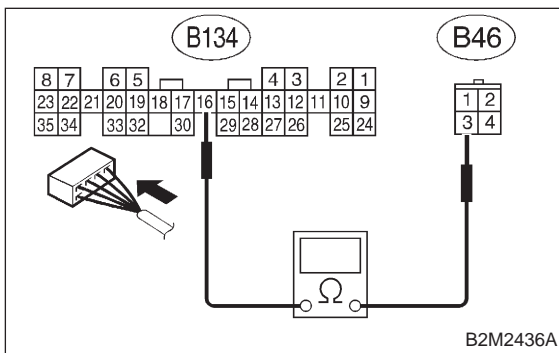

- CHECK** : *Is the resistance less than 1 Ω?*
- YES** : Go to step **9E8**.
- NO** : Repair open circuit in harness between ECM and fuel pump relay connector.

9E8 : CHECK POOR CONTACT.

Check poor contact in ECM connector.

<Ref. to FOREWORD [T3C1].>

- CHECK** : *Is there poor contact in ECM connector?*
- YES** : Repair poor contact in ECM connector.
- NO** : Check fuel injector circuit. <Ref. to 2-7 [T9F0].>

F: FUEL INJECTOR CIRCUIT

CAUTION:

- Check or repair only faulty parts.
- After repair or replacement of faulty parts, conduct CLEAR MEMORY MODE <Ref. to 2-7 [T3D0].> and INSPECTION MODE <Ref. to 2-7 [T3E0].>

● WIRING DIAGRAM:

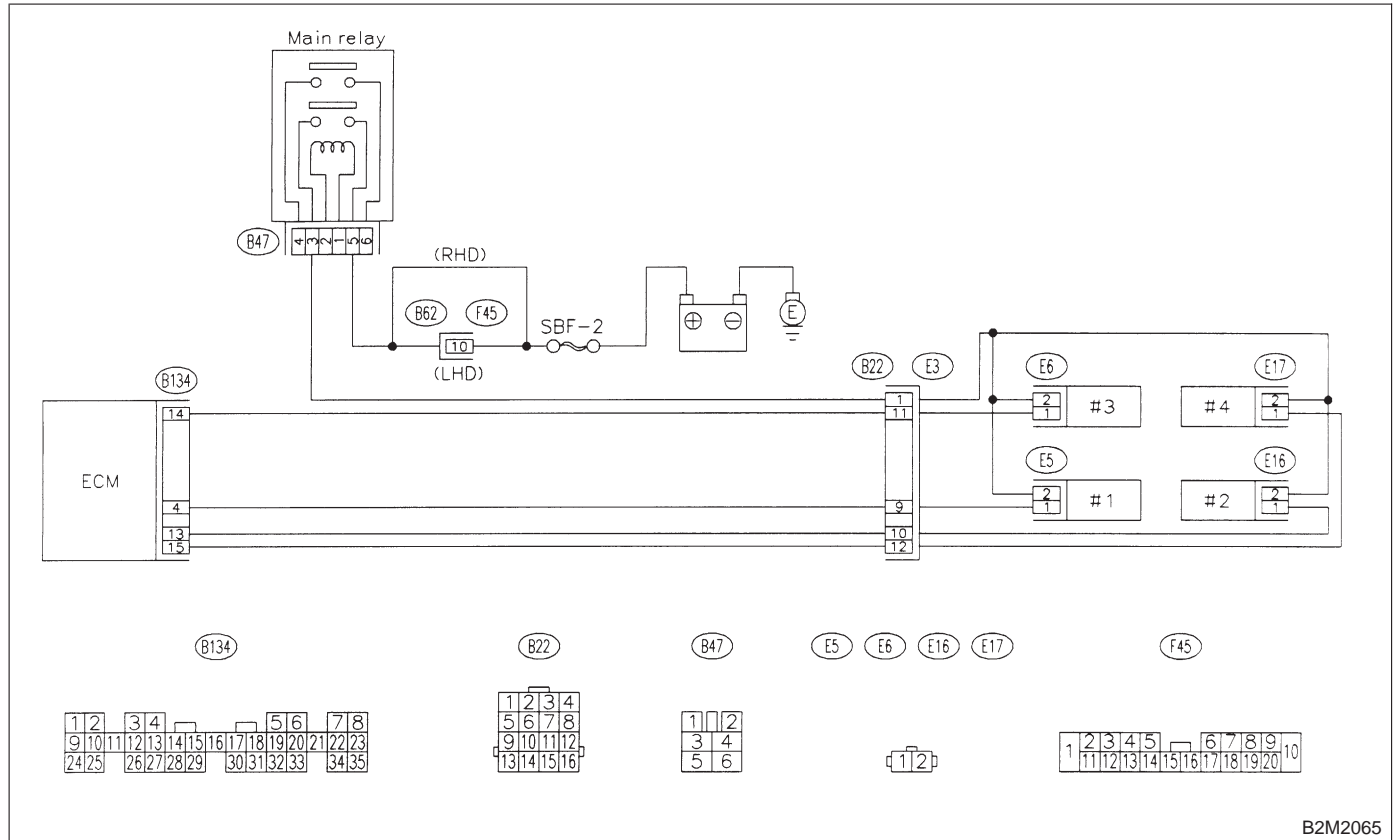

B2M2065

9F1 : CHECK OUTPUT SIGNAL FROM ECM.

- 1) Turn ignition switch to ON.
- 2) Measure voltage between ECM connector and chassis ground on faulty cylinders.

Connector & terminal

- #1 (B134) No. 4 (+) — Chassis ground (-):
- #2 (B134) No. 13 (+) — Chassis ground (-):
- #3 (B134) No. 14 (+) — Chassis ground (-):
- #4 (B134) No. 15 (+) — Chassis ground (-):

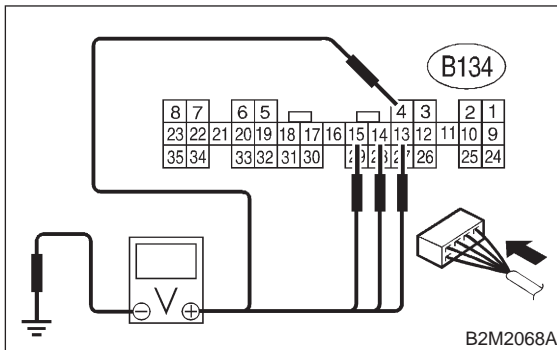

- CHECK** : Is the voltage more than 10 V?
- YES** : Go to step 9F6.
- NO** : Go to step 9F2.

9F2 : CHECK HARNESS BETWEEN FUEL INJECTOR AND ECM CONNECTOR.

- 1) Turn ignition switch to OFF.
- 2) Disconnect connector from fuel injector on faulty cylinders.
- 3) Measure voltage between ECM connector and engine ground on faulty cylinders.

Connector & terminal

- #1 (E5) No. 1 — Engine ground:
- #2 (E16) No. 1 — Engine ground:
- #3 (E6) No. 1 — Engine ground:
- #4 (E17) No. 1 — Engine ground:

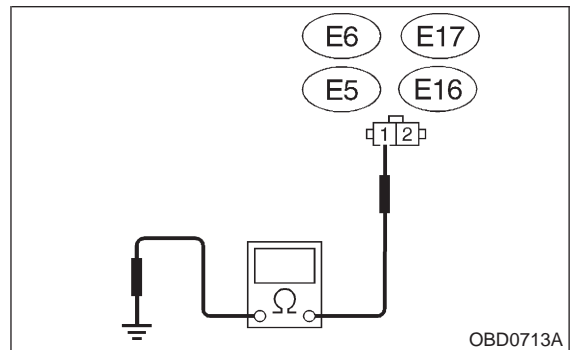

- CHECK** : Is the resistance less than 10 Ω?
- YES** : Repair ground short circuit in harness between fuel injector and ECM connector.
- NO** : Go to step 9F3.

2-7 [T9F3]

ON-BOARD DIAGNOSTICS II SYSTEM

9. Diagnostics for Engine Starting Failure [2200 cc Model]

9F3 : CHECK HARNESS BETWEEN FUEL INJECTOR AND ECM CONNECTOR.

Measure resistance of harness connector between ECM connector and fuel injector on faulty cylinders.

Connector & terminal

#1 (B134) No. 4 — (E5) No. 1:

#2 (B134) No. 13 — (E16) No. 1:

#3 (B134) No. 14 — (E6) No. 1:

#4 (B134) No. 15 — (E17) No. 1:

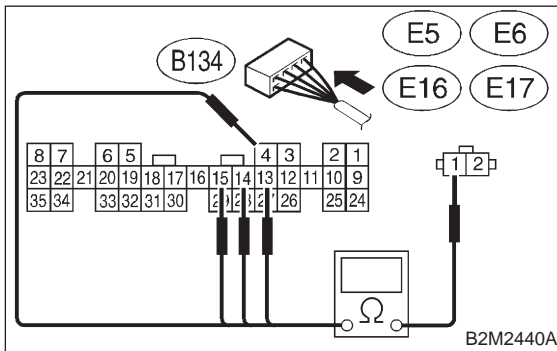

CHECK : Is the resistance less than 1 Ω?

YES : Go to step 9F4.

NO : Repair harness and connector.

NOTE:

In this case, repair the following:

- Open circuit in harness between ECM and fuel injector connector
- Poor contact in coupling connector (B22)

9F4 : CHECK FUEL INJECTOR.

Measure resistance between fuel injector terminals on faulty cylinder.

Terminals

No. 1 — No. 2:

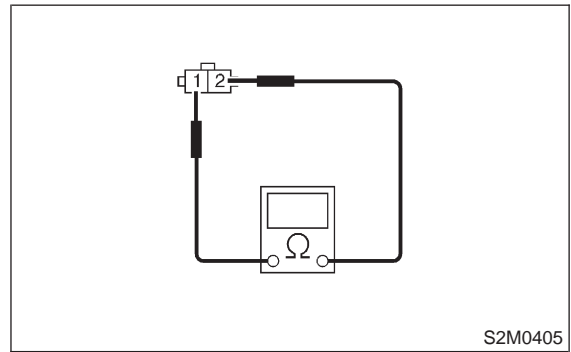

CHECK : Is the resistance between 5 and 20 Ω?

YES : Go to step 9F5.

NO : Replace faulty fuel injector. <Ref. to 2-7 [W14A0].>

9F5 : CHECK POWER SUPPLY LINE.

- 1) Turn ignition switch to ON.
- 2) Measure voltage between fuel injector and engine ground on faulty cylinders.

Connector & terminal

- #1 (E5) No. 2 (+) — Engine ground (-):
- #2 (E16) No. 2 (+) — Engine ground (-):
- #3 (E6) No. 2 (+) — Engine ground (-):
- #4 (E17) No. 2 (+) — Engine ground (-):

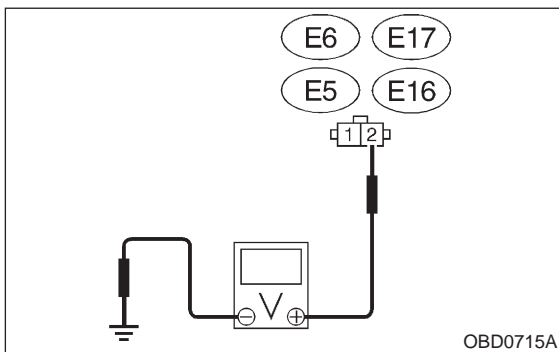

- CHECK** : *Is the voltage more than 10 V?*
- YES** : Repair poor contact in all connectors in fuel injector circuit.
- NO** : Repair harness and connector.

NOTE:

In this case, repair the following:

- Open circuit in harness between main relay and fuel injector connector on faulty cylinders
- Poor contact in coupling connector (B22)
- Poor contact in main relay connector
- Poor contact in fuel injector connector on faulty cylinders

9F6 : CHECK HARNESS BETWEEN FUEL INJECTOR AND ECM CONNECTOR.

- 1) Turn ignition switch to OFF.
- 2) Disconnect connector from fuel injector on faulty cylinder.
- 3) Turn ignition switch to ON.
- 4) Measure voltage between ECM connector and chassis ground on faulty cylinders.

Connector & terminal

- #1 (B134) No. 4 (+) — Chassis ground (-):
- #2 (B134) No. 13 (+) — Chassis ground (-):
- #3 (B134) No. 14 (+) — Chassis ground (-):
- #4 (B134) No. 15 (+) — Chassis ground (-):

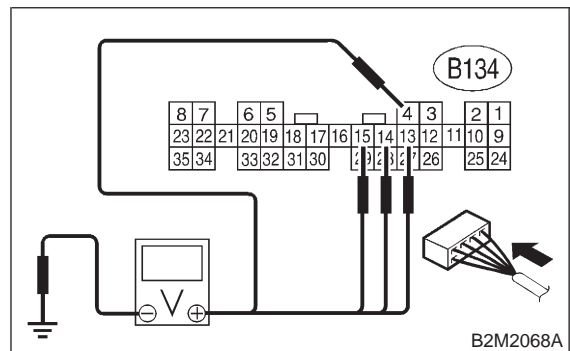

- CHECK** : *Is the voltage more than 10 V?*
- YES** : Repair battery short circuit in harness between ECM and fuel injector. After repair, replace ECM. <Ref. to 2-7 [W15A1].>
- NO** : Go to step 9F7.

2-7 [T9F7]

ON-BOARD DIAGNOSTICS II SYSTEM

9. Diagnostics for Engine Starting Failure [2200 cc Model]

9F7 : CHECK FUEL INJECTOR.

- 1) Turn ignition switch to OFF.
- 2) Measure resistance between fuel injector terminals on faulty cylinder.

Terminals

No. 1 — No. 2:

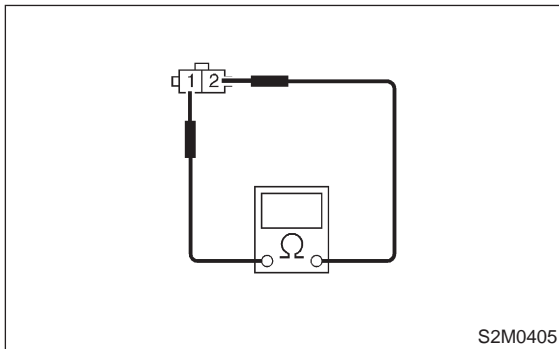

CHECK : *Is the resistance less than 1 Ω ?*

YES : Replace faulty fuel injector <Ref. to 2-7 [W14A0].> and ECM <Ref. to 2-7 [W15A1].>.

NO : Go to step **9F8**.

9F8 : CHECK POOR CONTACT.

Check poor contact in ECM connector. <Ref. to FOREWORD [T3C1].>

CHECK : *Is there poor contact in ECM connector?*

YES : Repair poor contact in ECM connector.

NO : Check crankshaft position sensor circuit.

NOTE:

- California spec. vehicles: <Ref. to 2-7 [T9G0].>
- Except California spec. vehicles: <Ref. to 2-7 [T9H0].>

G: CRANKSHAFT POSITION SENSOR CIRCUIT (CALIFORNIA SPEC. VEHICLES)

CAUTION:

After repair or replacement of faulty parts, conduct CLEAR MEMORY MODE <Ref. to 2-7 [T3D0].> and INSPECTION MODE <Ref. to 2-7 [T3E0].>.

NOTE:

Check crankshaft position sensor circuit.

- LHD vehicles: <Ref. to 2-7 [T12AD0].>
- RHD vehicles: <Ref. to 2-7 [T13AD0].>

● **WIRING DIAGRAM:**

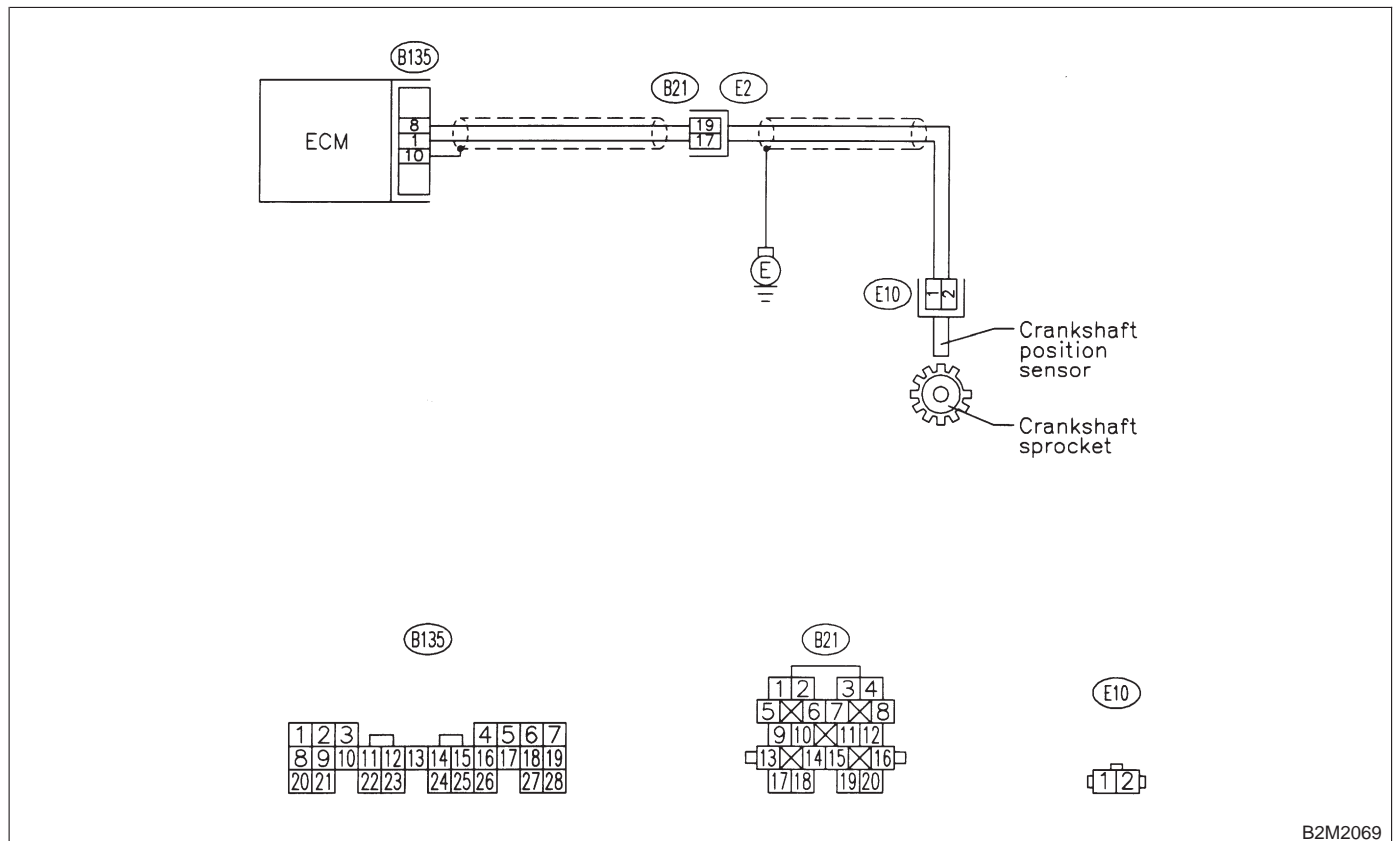

B2M2069

H: CRANKSHAFT POSITION SENSOR CIRCUIT (EXCEPT CALIFORNIA SPEC. VEHICLES)

CAUTION:

After repair or replacement of faulty parts, conduct CLEAR MEMORY MODE <Ref. to 2-7 [T3D0].> and INSPECTION MODE <Ref. to 2-7 [T3E0].>

NOTE:

Check crankshaft position sensor circuit.

- LHD vehicles: <Ref. to 2-7 [T14AC0].>
- RHD vehicles: <Ref. to 2-7 [T15AC0].>

● **WIRING DIAGRAM:**

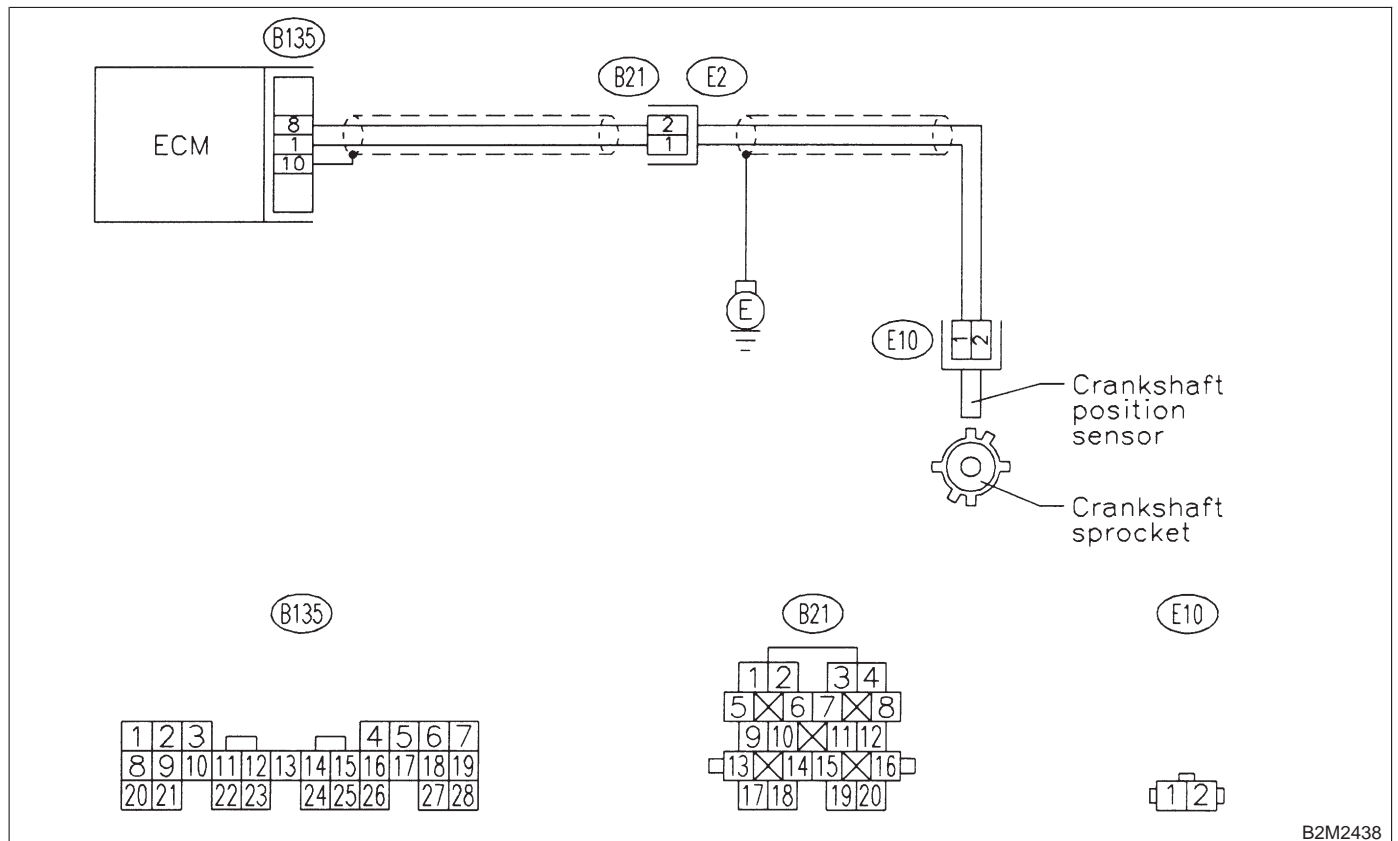

B2M2438

I: CAMSHAFT POSITION SENSOR CIRCUIT

CAUTION:

After repair or replacement of faulty parts, conduct CLEAR MEMORY MODE <Ref. to 2-7 [T3D0].> and INSPECTION MODE <Ref. to 2-7 [T3E0].>

NOTE:

Check camshaft position sensor circuit.

- California spec. LHD vehicles: <Ref. to 2-7 [T12AF0].>
- California spec. RHD vehicles: <Ref. to 2-7 [T13AF0].>
- Except California spec. LHD vehicles: <Ref. to 2-7 [T14AE0].>
- Except California spec. RHD vehicles: <Ref. to 2-7 [T15AE0].>

● WIRING DIAGRAM:

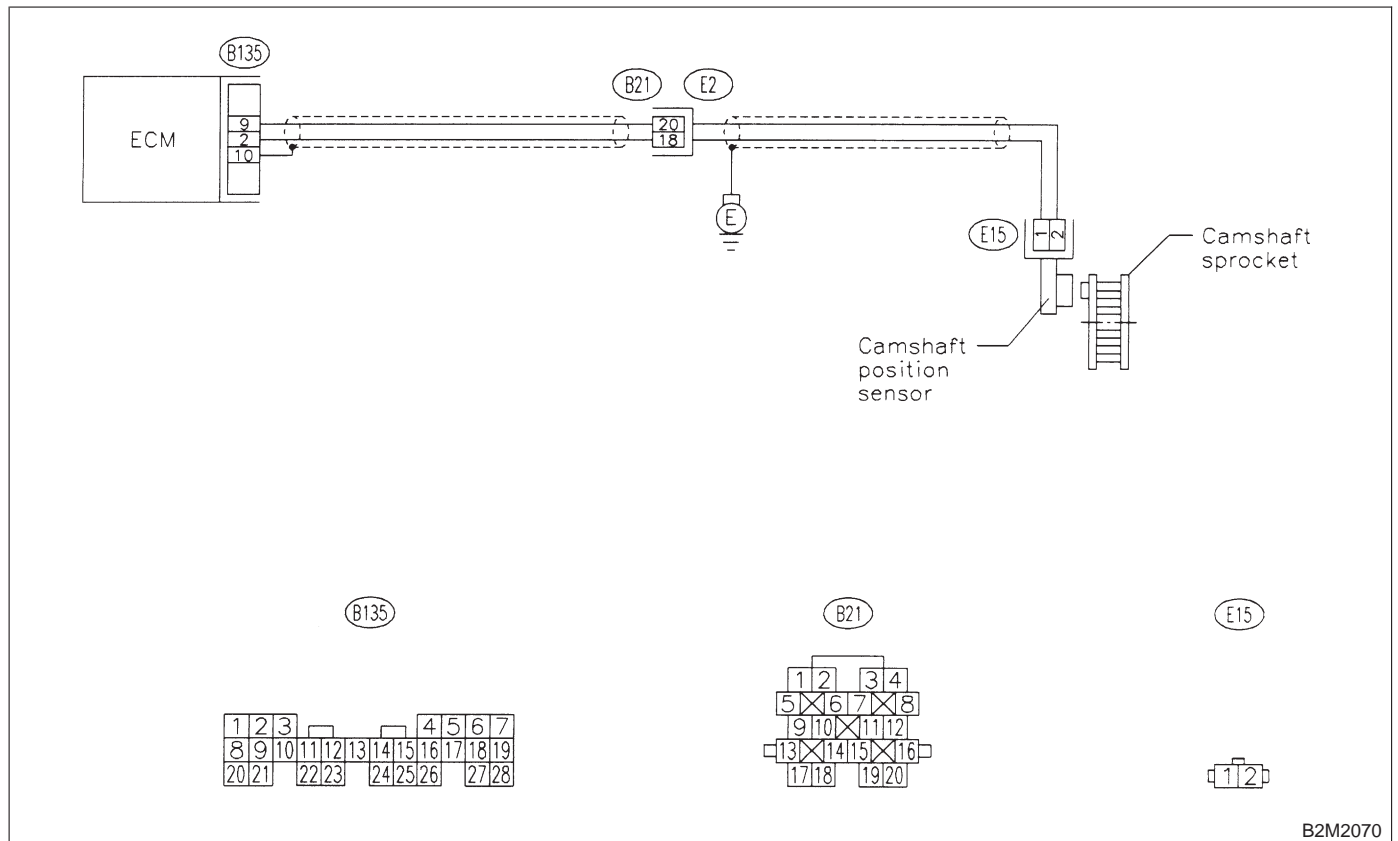

MEMO: