

1. Manual Transmission and Differential

Item		Model		
		AWD		
		2200 cc	2500 cc	2500 cc OUTBACK
Type		5-forward speeds with synchromesh and 1-reverse		
Transmission gear ratio		1st	3.545	
		2nd	2.111	
		3rd	1.448	
		4th	1.088	
		5th	0.780	0.871
		Reverse	3.333	
Front reduction gear	Final	Type of gear	Hypoid	
		Gear ratio	3.900	4.111
Rear reduction gear	Transfer	Type of gear	Helical	
		Gear ratio	1.000	
	Final	Type of gear	Hypoid	
		Gear ratio	3.900	4.111
Front differential	Type and number of gear		Straight bevel gear (Bevel pinion: 2, Bevel gear: 2)	
Center differential	Type and number of gear		Straight bevel gear (Bevel pinion: 2, Bevel gear: 2 and viscous coupling)	
Transmission gear oil		GL-5		
Transmission oil capacity		3.5 ℓ (3.7 US qt, 3.1 Imp qt)		

2. Transmission Gear Oil

Recommended oil

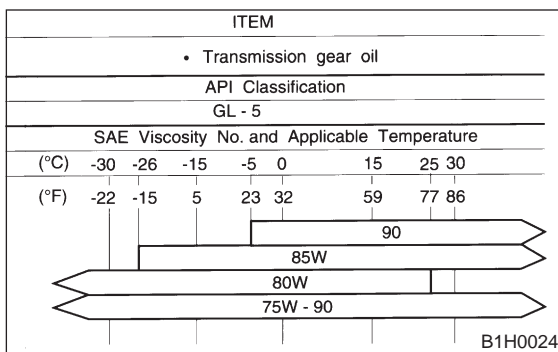

3. Transmission Case Assembly

Drive pinion shim adjustment

Drive pinion shim			
Part No.	Thickness mm (in)	Part No.	Thickness mm (in)
32295AA031	0.150 (0.0059)	32295AA071	0.250 (0.0098)
32295AA041	0.175 (0.0069)	32295AA081	0.275 (0.0108)
32295AA051	0.200 (0.0079)	32295AA091	0.300 (0.0118)
32295AA061	0.225 (0.0089)	32295AA101	0.500 (0.0197)

Hypoid gear backlash

0.13 — 0.18 mm (0.0051 — 0.0071 in)

Selection of main shaft rear plate

Main shaft rear plate		
Dimension "A" mm (in)	Part No.	Mark
4.00 — 4.13 (0.1575 — 0.1626)	32294AA041	1
3.87 — 3.99 (0.1524 — 0.1571)	32294AA051	2

1. Manual Transmission and Differential

Item		Model		
		AWD		
		2200 cc	2500 cc	2500 cc OUTBACK
Type		5-forward speeds with synchromesh and 1-reverse		
Transmission gear ratio		1st	3.545	
		2nd	2.111	
		3rd	1.448	
		4th	1.088	
		5th	0.780	0.871
		Reverse	3.333	
Front reduction gear	Final	Type of gear	Hypoid	
		Gear ratio	3.900	4.111
Rear reduction gear	Transfer	Type of gear	Helical	
		Gear ratio	1.000	
	Final	Type of gear	Hypoid	
		Gear ratio	3.900	4.111
Front differential	Type and number of gear		Straight bevel gear (Bevel pinion: 2, Bevel gear: 2)	
Center differential	Type and number of gear		Straight bevel gear (Bevel pinion: 2, Bevel gear: 2 and viscous coupling)	
Transmission gear oil		GL-5		
Transmission oil capacity		3.5 ℓ (3.7 US qt, 3.1 Imp qt)		

2. Transmission Gear Oil

Recommended oil

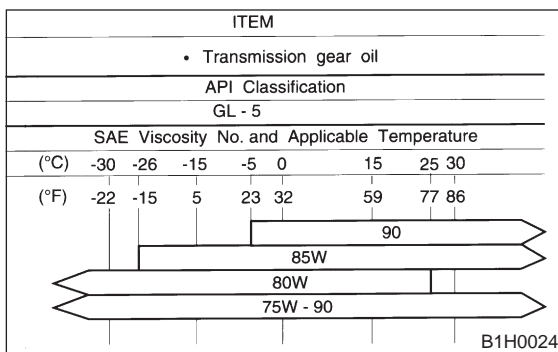

3. Transmission Case Assembly

Drive pinion shim adjustment

Drive pinion shim			
Part No.	Thickness mm (in)	Part No.	Thickness mm (in)
32295AA031	0.150 (0.0059)	32295AA071	0.250 (0.0098)
32295AA041	0.175 (0.0069)	32295AA081	0.275 (0.0108)
32295AA051	0.200 (0.0079)	32295AA091	0.300 (0.0118)
32295AA061	0.225 (0.0089)	32295AA101	0.500 (0.0197)

Hypoid gear backlash

0.13 — 0.18 mm (0.0051 — 0.0071 in)

Selection of main shaft rear plate

Main shaft rear plate		
Dimension "A" mm (in)	Part No.	Mark
4.00 — 4.13 (0.1575 — 0.1626)	32294AA041	1
3.87 — 3.99 (0.1524 — 0.1571)	32294AA051	2

1. Manual Transmission and Differential

Item		Model		
		AWD		
		2200 cc	2500 cc	2500 cc OUTBACK
Type		5-forward speeds with synchromesh and 1-reverse		
Transmission gear ratio		1st	3.545	
		2nd	2.111	
		3rd	1.448	
		4th	1.088	
		5th	0.780	0.871
		Reverse	3.333	
Front reduction gear	Final	Type of gear	Hypoid	
		Gear ratio	3.900	4.111
Rear reduction gear	Transfer	Type of gear	Helical	
		Gear ratio	1.000	
	Final	Type of gear	Hypoid	
		Gear ratio	3.900	4.111
Front differential	Type and number of gear		Straight bevel gear (Bevel pinion: 2, Bevel gear: 2)	
Center differential	Type and number of gear		Straight bevel gear (Bevel pinion: 2, Bevel gear: 2 and viscous coupling)	
Transmission gear oil		GL-5		
Transmission oil capacity		3.5 ℓ (3.7 US qt, 3.1 Imp qt)		

2. Transmission Gear Oil

Recommended oil

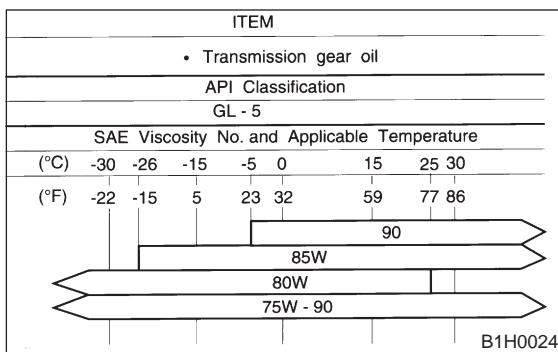

3. Transmission Case Assembly

Drive pinion shim adjustment

Drive pinion shim			
Part No.	Thickness mm (in)	Part No.	Thickness mm (in)
32295AA031	0.150 (0.0059)	32295AA071	0.250 (0.0098)
32295AA041	0.175 (0.0069)	32295AA081	0.275 (0.0108)
32295AA051	0.200 (0.0079)	32295AA091	0.300 (0.0118)
32295AA061	0.225 (0.0089)	32295AA101	0.500 (0.0197)

Hypoid gear backlash

0.13 — 0.18 mm (0.0051 — 0.0071 in)

Selection of main shaft rear plate

Main shaft rear plate		
Dimension "A" mm (in)	Part No.	Mark
4.00 — 4.13 (0.1575 — 0.1626)	32294AA041	1
3.87 — 3.99 (0.1524 — 0.1571)	32294AA051	2

4. Drive Pinion Assembly

Preload adjustment of thrust bearing

Starting torque

0.3 — 0.8 N·m (3 — 8 kg-m, 2.6 — 6.9 in-lb)

Adjusting washer No. 1	
Part No.	Thickness mm (in)
803025051	3.925 (0.1545)
803025052	3.950 (0.1555)
803025053	3.975 (0.1565)
803025054	4.000 (0.1575)
803025055	4.025 (0.1585)
803025056	4.050 (0.1594)
803025057	4.075 (0.1604)

Adjusting washer No. 2	
Part No.	Thickness mm (in)
803025059	3.850 (0.1516)
803025054	4.000 (0.1575)
803025058	4.150 (0.1634)

Assemble a driven shaft and 1st driven gear that are selected for the proper radial clearance adjustment

Driven shaft		1st driven gear
Part No.	Diameter A mm (in)	Part No.
32229AA150	49.959 — 49.966 (1.9669 — 1.9672)	32231AA730
32229AA140	49.967 — 49.975 (1.9672 — 1.9675)	32231AA720

5. Reverse Idler Gear

Adjustment of reverse idler gear position

Reverse idler gear to transmission case (LH) wall clearance

6.0 — 7.5 mm (0.236 — 0.295 in)

Reverse shifter lever		
Part No.	Mark	Remarks
32820AA070	7	Further from case wall
32820AA080	8	Standard
32820AA090	9	Closer to the case wall

After installing a suitable reverse shifter lever, adjust reverse idler gear to transmission case wall clearance to within 0 to 0.5 mm (0 to 0.020 in) using washers.

Washer (20.5 × 26 × t)			
Part No.	Thickness mm (in)	Part No.	Thickness mm (in)
803020151	0.4 (0.016)	803020154	1.9 (0.075)
803020152	1.1 (0.043)	803020155	2.3 (0.091)
803020153	1.5 (0.059)	—	—

4. Drive Pinion Assembly

Preload adjustment of thrust bearing

Starting torque

0.3 — 0.8 N·m (3 — 8 kg-m, 2.6 — 6.9 in-lb)

Adjusting washer No. 1	
Part No.	Thickness mm (in)
803025051	3.925 (0.1545)
803025052	3.950 (0.1555)
803025053	3.975 (0.1565)
803025054	4.000 (0.1575)
803025055	4.025 (0.1585)
803025056	4.050 (0.1594)
803025057	4.075 (0.1604)

Adjusting washer No. 2	
Part No.	Thickness mm (in)
803025059	3.850 (0.1516)
803025054	4.000 (0.1575)
803025058	4.150 (0.1634)

Assemble a driven shaft and 1st driven gear that are selected for the proper radial clearance adjustment

Driven shaft		1st driven gear
Part No.	Diameter A mm (in)	Part No.
32229AA150	49.959 — 49.966 (1.9669 — 1.9672)	32231AA730
32229AA140	49.967 — 49.975 (1.9672 — 1.9675)	32231AA720

5. Reverse Idler Gear

Adjustment of reverse idler gear position

Reverse idler gear to transmission case (LH) wall clearance

6.0 — 7.5 mm (0.236 — 0.295 in)

Reverse shifter lever		
Part No.	Mark	Remarks
32820AA070	7	Further from case wall
32820AA080	8	Standard
32820AA090	9	Closer to the case wall

After installing a suitable reverse shifter lever, adjust reverse idler gear to transmission case wall clearance to within 0 to 0.5 mm (0 to 0.020 in) using washers.

Washer (20.5 × 26 × t)			
Part No.	Thickness mm (in)	Part No.	Thickness mm (in)
803020151	0.4 (0.016)	803020154	1.9 (0.075)
803020152	1.1 (0.043)	803020155	2.3 (0.091)
803020153	1.5 (0.059)	—	—

6. Shifter Fork And Rod

Select suitable shifter forks so that both coupling sleeve and reverse driven gear are positioned in the center of their synchromesh mechanisms.

1st-2nd shifter fork		
Part No.	Mark	Remarks
32804AA060	1	Approach to 1st gear by 0.2 mm (0.008 in)
32804AA070	No mark	Standard
32804AA080	3	Approach to 2nd gear by 0.2 mm (0.008 in)

3rd-4th shifter fork		
Part No.	Mark	Remarks
32810AA061	1	Approach to 4th gear by 0.2 mm (0.008 in)
32810AA071	No mark	Standard
32810AA101	3	Approach to 3rd gear by 0.2 mm (0.008 in)

5th shifter fork		
Part No.	Mark	Remarks
32812AA200	1	Approach to 5th gear by 0.2 mm (0.008 in)
32812AA210	No mark	Standard
32812AA220	3	Become distant from 5th gear by 0.2 mm (0.008 in)

Rod end clearance

- A: 1st-2nd — 3rd-4th
0.5 — 1.5 mm (0.020 — 0.059 in)
- B: 3rd-4th — 5th
0.6 — 1.4 mm (0.024 — 0.055 in)

7. Transfer Case

Neutral position adjustment

Adjustment shim	
Part No.	Thickness mm (in)
32190AA000	0.15 (0.0059)
32190AA010	0.30 (0.0118)

Reverse accent shaft		
Part No.	Mark	Remarks
32188AA090	X	Neutral position is closer to 1st.
32188AA100	Y	Standard
32188AA110	Z	Neutral position is closer to reverse gear.

Reverse check plate adjustment

Reverse check plate			
Part No.	Mark	Angle θ	Remarks
32189AA000	0	28°	Arm stops closer to 5th gear.
32189AA010	1	31°	Arm stops closer to 5th gear.
33189AA020	2	34°	Arm stops in the center.
32189AA030	3	37°	Arm stops closer to reverse gear.
32189AA040	4	40°	Arm stops closer to reverse gear.

6. Shifter Fork And Rod

Select suitable shifter forks so that both coupling sleeve and reverse driven gear are positioned in the center of their synchromesh mechanisms.

1st-2nd shifter fork		
Part No.	Mark	Remarks
32804AA060	1	Approach to 1st gear by 0.2 mm (0.008 in)
32804AA070	No mark	Standard
32804AA080	3	Approach to 2nd gear by 0.2 mm (0.008 in)

3rd-4th shifter fork		
Part No.	Mark	Remarks
32810AA061	1	Approach to 4th gear by 0.2 mm (0.008 in)
32810AA071	No mark	Standard
32810AA101	3	Approach to 3rd gear by 0.2 mm (0.008 in)

5th shifter fork		
Part No.	Mark	Remarks
32812AA200	1	Approach to 5th gear by 0.2 mm (0.008 in)
32812AA210	No mark	Standard
32812AA220	3	Become distant from 5th gear by 0.2 mm (0.008 in)

Rod end clearance

- A: 1st-2nd — 3rd-4th
0.5 — 1.5 mm (0.020 — 0.059 in)
- B: 3rd-4th — 5th
0.6 — 1.4 mm (0.024 — 0.055 in)

7. Transfer Case

Neutral position adjustment

Adjustment shim	
Part No.	Thickness mm (in)
32190AA000	0.15 (0.0059)
32190AA010	0.30 (0.0118)

Reverse accent shaft		
Part No.	Mark	Remarks
32188AA090	X	Neutral position is closer to 1st.
32188AA100	Y	Standard
32188AA110	Z	Neutral position is closer to reverse gear.

Reverse check plate adjustment

Reverse check plate			
Part No.	Mark	Angle θ	Remarks
32189AA000	0	28°	Arm stops closer to 5th gear.
32189AA010	1	31°	Arm stops closer to 5th gear.
33189AA020	2	34°	Arm stops in the center.
32189AA030	3	37°	Arm stops closer to reverse gear.
32189AA040	4	40°	Arm stops closer to reverse gear.

8. Extension Assembly

Thrust washer (52 × 61 × t) to ball bearing side clearance

0.05 — 0.30 mm (0.0020 — 0.0118 in)

Thrust washer (52 × 61 × t)	
Part No.	Thickness mm (in)
803052021	0.50 (0.0197)
803052022	0.75 (0.0295)
803052023	1.00 (0.0394)

Thrust washer to center differential side clearance
0.15 — 0.35 mm (0.0059 — 0.0138 in)

Thrust washer (52 × 61 × t)	
Part No.	Thickness mm (in)
803036050	0.9 (0.035)
803036054	1.0 (0.039)
803036051	1.1 (0.043)
803036055	1.2 (0.047)
803036052	1.3 (0.051)
803036056	1.4 (0.055)
803036053	1.5 (0.059)
803036057	1.6 (0.063)
803036058	1.7 (0.067)

9. Front Differential

Bevel gear to pinion backlash

0.13 — 0.18 mm (0.0051 — 0.0071 in)

Washer (38.1 × 50 × t)			
Part No.	Thickness mm (in)	Part No.	Thickness mm (in)
803038021	0.925 — 0.950 (0.0364 — 0.0374)	803038023	1.025 — 1.050 (0.0404 — 0.0413)
	803038022		0.975 — 1.000 (0.0384 — 0.0394)

Pinion shaft to axle drive shaft clearance
0 — 0.2 mm (0 — 0.008 in)

Snap ring (Outer-28)			
Part No.	Thickness mm (in)	Part No.	Thickness mm (in)
805028011	1.05 (0.0413)	805028012	1.20 (0.0472)

8. Extension Assembly

Thrust washer (52 × 61 × t) to ball bearing side clearance

0.05 — 0.30 mm (0.0020 — 0.0118 in)

Thrust washer (52 × 61 × t)	
Part No.	Thickness mm (in)
803052021	0.50 (0.0197)
803052022	0.75 (0.0295)
803052023	1.00 (0.0394)

Thrust washer to center differential side clearance
0.15 — 0.35 mm (0.0059 — 0.0138 in)

Thrust washer (52 × 61 × t)	
Part No.	Thickness mm (in)
803036050	0.9 (0.035)
803036054	1.0 (0.039)
803036051	1.1 (0.043)
803036055	1.2 (0.047)
803036052	1.3 (0.051)
803036056	1.4 (0.055)
803036053	1.5 (0.059)
803036057	1.6 (0.063)
803036058	1.7 (0.067)

9. Front Differential

Bevel gear to pinion backlash

0.13 — 0.18 mm (0.0051 — 0.0071 in)

Washer (38.1 × 50 × t)			
Part No.	Thickness mm (in)	Part No.	Thickness mm (in)
803038021	0.925 — 0.950 (0.0364 — 0.0374)	803038023	1.025 — 1.050 (0.0404 — 0.0413)
	803038022		0.975 — 1.000 (0.0384 — 0.0394)

Pinion shaft to axle drive shaft clearance
0 — 0.2 mm (0 — 0.008 in)

Snap ring (Outer-28)			
Part No.	Thickness mm (in)	Part No.	Thickness mm (in)
805028011	1.05 (0.0413)	805028012	1.20 (0.0472)

COMPONENT PARTS

1. Transmission Case

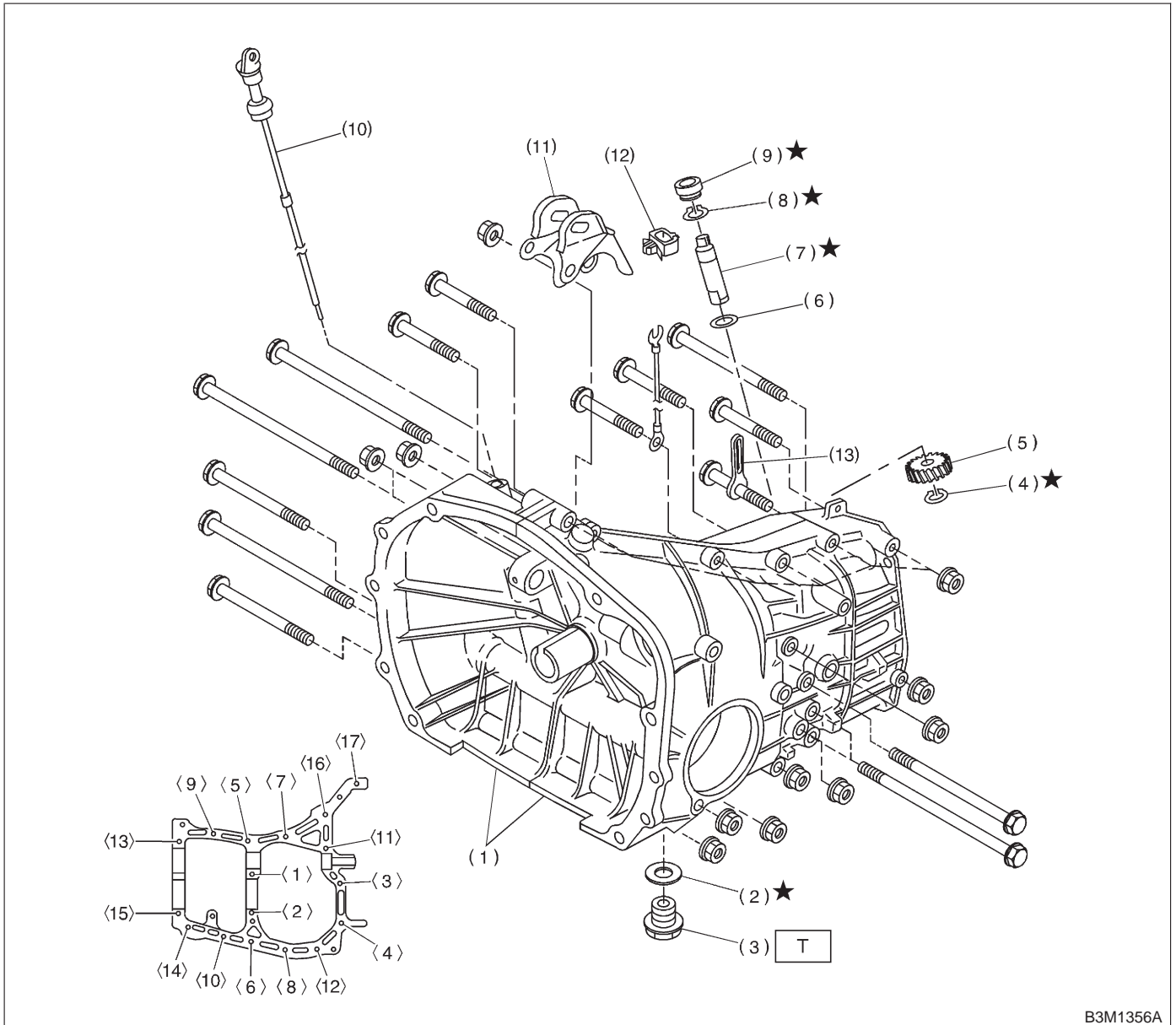

B3M1356A

- (1) Transmission case ASSY
- (2) Gasket
- (3) Drain plug
- (4) Snap ring (Outer)
- (5) Speedometer driven gear
- (6) Washer
- (7) Speedometer shaft
- (8) Snap ring (Outer)
- (9) Oil seal
- (10) Oil level gauge
- (11) Pitching stopper bracket
- (12) Clamp

(13) Clip

Tightening torque: N·m (kg·m, ft·lb)
T: 44±3 (4.5±0.3, 32.5±2.2)

Size	All models	Torque
8 mm bolt	<5> — <15>	25±2 N·m (2.5±0.2 kg·m, 18.1±1.4 ft·lb)
10 mm bolt	<1> — <4> <16> — <17>	39±2 N·m (4.0±0.2 kg·m, 28.9±1.4 ft·lb)

2. Drive Pinion Assembly

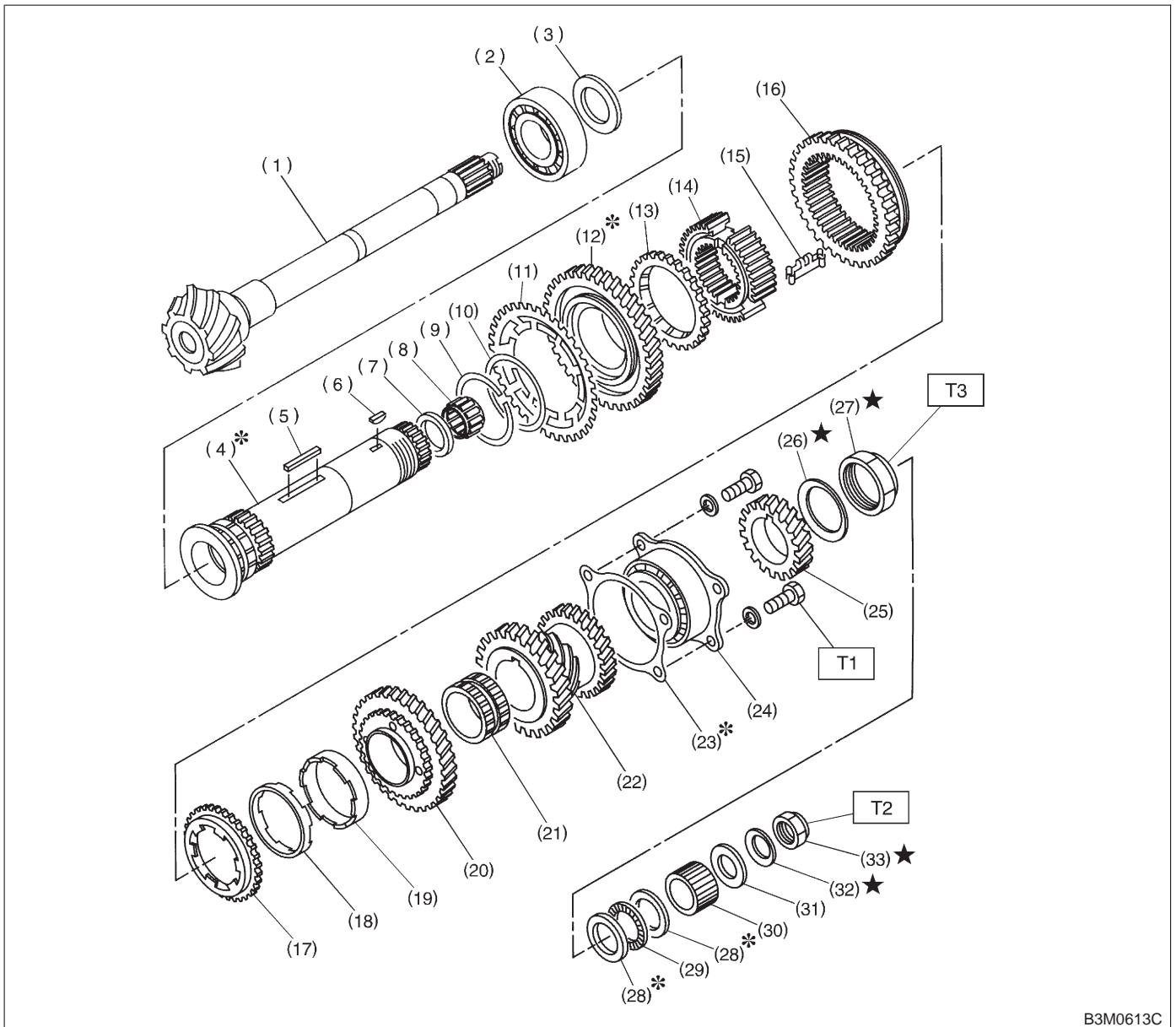

B3M0613C

- | | | |
|-------------------------|-------------------------------|-------------------------------------|
| (1) Drive pinion shaft | (14) 1st-2nd synchronizer hub | (27) Lock nut |
| (2) Roller bearing | (15) Insert key | (28) Washer |
| (3) Washer | (16) Reverse driven gear | (29) Thrust bearing |
| (4) Driven shaft | (17) Outer baulk ring | (30) Differential bevel gear sleeve |
| (5) Key | (18) Synchro cone | (31) Washer |
| (6) Woodruff key | (19) Inner baulk ring | (32) Lock washer |
| (7) Drive pinion collar | (20) 2nd driven gear | (33) Lock nut |
| (8) Needle bearing | (21) 2nd driven gear bush | |
| (9) Snap ring (Outer) | (22) 3rd-4th driven gear | |
| (10) Washer | (23) Driven pinion shim | |
| (11) Sub gear | (24) Roller bearing | |
| (12) 1st driven gear | (25) 5th driven gear | |
| (13) Baulk ring | (26) Lock washer | |

Tightening torque: N-m (kg-m, ft-lb)

T1: 29±3 (3.0±0.3, 21.7±2.2)

T2: 118±8 (12.0±0.8, 86.8±5.8)

T3: 265±10 (27±1, 195±7)

3-1 [C3A0]

3. Main Shaft Assembly

COMPONENT PARTS

3. Main Shaft Assembly

A: 2200 cc MODEL

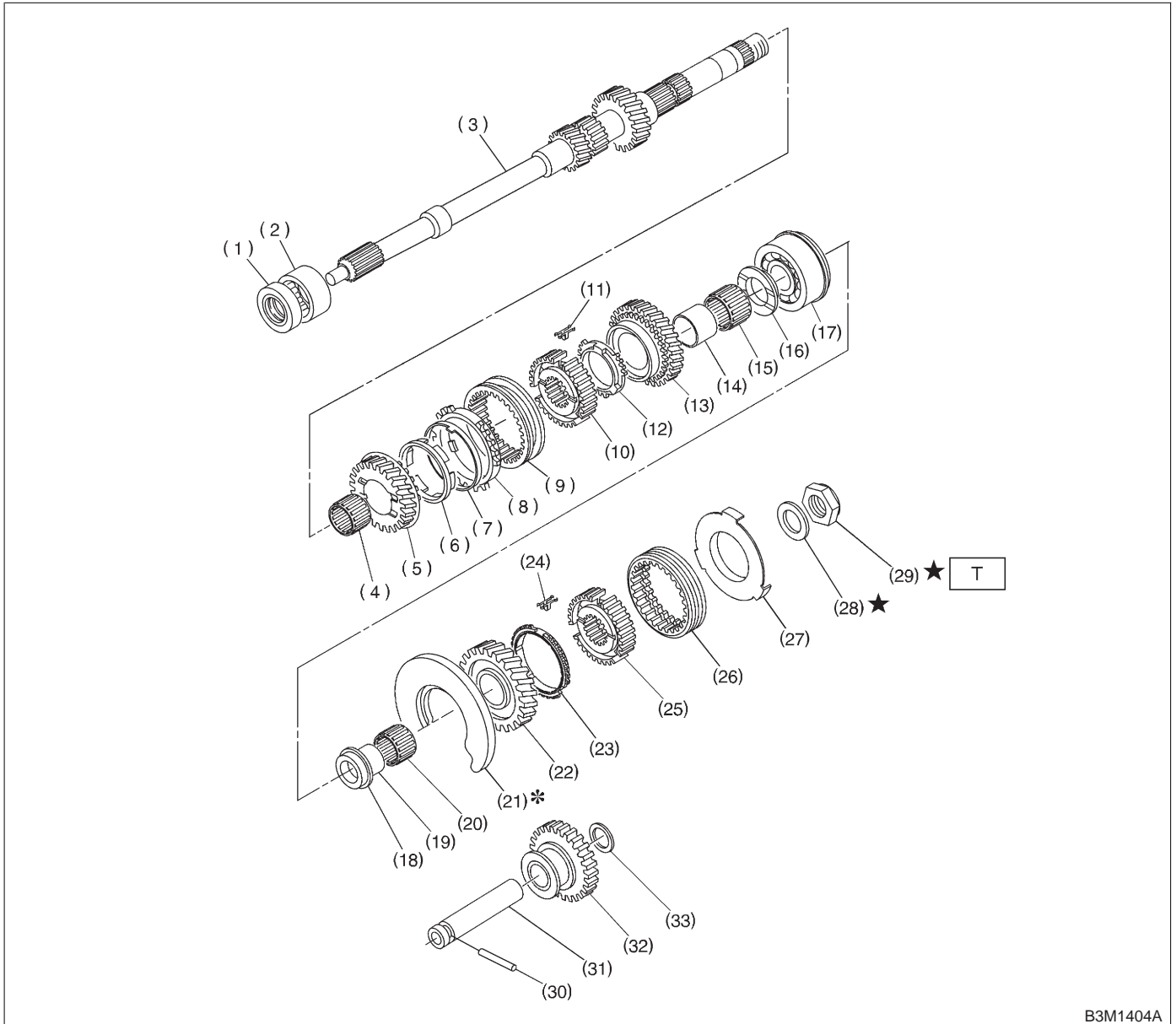

B3M1404A

- | | | |
|------------------------------------|------------------------------------|---------------------------------|
| (1) Oil seal | (13) 4th drive gear | (25) Synchronizer hub (5th-Rev) |
| (2) Needle bearing | (14) 4th needle bearing race | (26) Coupling sleeve (5th-Rev) |
| (3) Transmission main shaft | (15) Needle bearing | (27) Insert stopper plate |
| (4) Needle bearing | (16) 4th gear thrust washer | (28) Lock washer |
| (5) 3rd drive gear | (17) Ball bearing | (29) Lock nut |
| (6) Inner baulk ring | (18) 5th gear thrust washer | (30) Straight pin |
| (7) Synchro cone | (19) 5th needle bearing race | (31) Reverse idler gear shaft |
| (8) Outer baulk ring | (20) Needle bearing | (32) Reverse idler gear |
| (9) Coupling sleeve (3rd-4th) | (21) Main shaft rear plate | (33) Washer |
| (10) Synchronizer hub (3rd-4th) | (22) 5th drive gear | |
| (11) Shifting insert key (3rd-4th) | (23) Baulk ring (5th) | |
| (12) Baulk ring (4th) | (24) Shifting insert key (5th-Rev) | |

Tightening torque: N-m (kg-m, ft-lb)

T: 118±6 (12.0±0.6, 86.8±4.3)

COMPONENT PARTS

[C3B0] 3-1
3. Main Shaft Assembly

B: 2500 cc MODEL

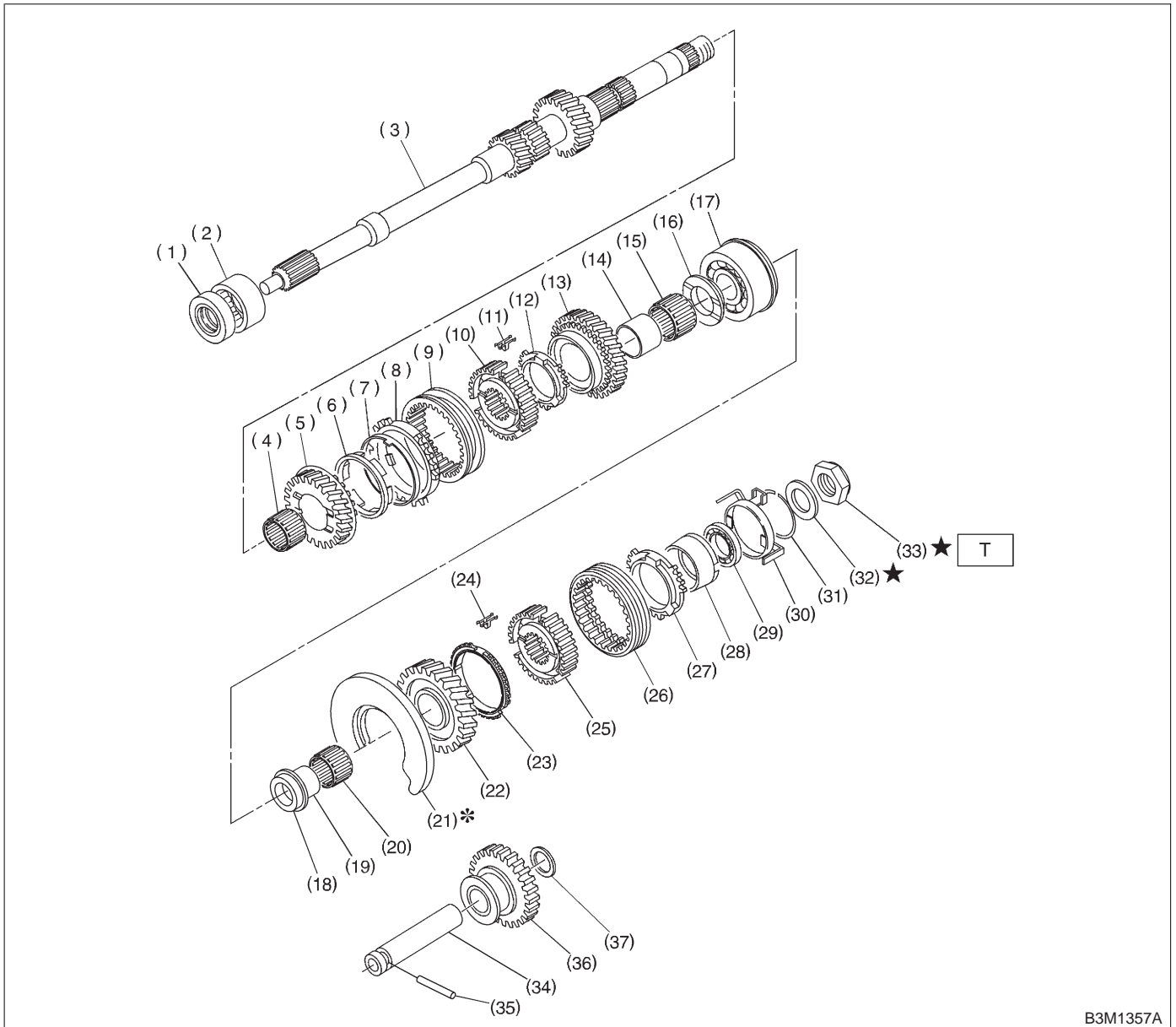

B3M1357A

- | | | |
|---------------------------------|---------------------------------|-------------------------------|
| (1) Oil seal | (15) Needle bearing | (29) Ball bearing |
| (2) Needle bearing | (16) 4th gear thrust washer | (30) Synchro cone stopper |
| (3) Transmission main shaft | (17) Ball bearing | (31) Snap ring |
| (4) Needle bearing | (18) 5th gear thrust washer | (32) Lock washer |
| (5) 3rd drive gear | (19) 5th needle bearing race | (33) Lock nut |
| (6) Inner baulk ring | (20) Needle bearing | (34) Straight pin |
| (7) Synchro cone (3rd) | (21)* Main shaft rear plate | (35) Reverse idler gear shaft |
| (8) Outer baulk ring | (22) 5th drive gear | (36) Reverse idler gear |
| (9) Coupling sleeve (3rd-4th) | (23) 5th baulk ring | (37) Washer |
| (10) Synchronizer hub (3rd-4th) | (24) Shift insert key (5th-Rev) | |
| (11) Shift insert key (3rd-4th) | (25) Synchronizer hub (5th-Rev) | |
| (12) 4th baulk ring | (26) Coupling sleeve | |
| (13) 4th drive gear | (27) Rev baulk ring | |
| (14) 4th needle bearing race | (28) Synchro cone (Rev) | |

Tightening torque: N-m (kg-m, ft-lb)
T: 118±6 (12.0±0.6, 86.8±4.3)

4. Shifter Fork and Shifter Rod

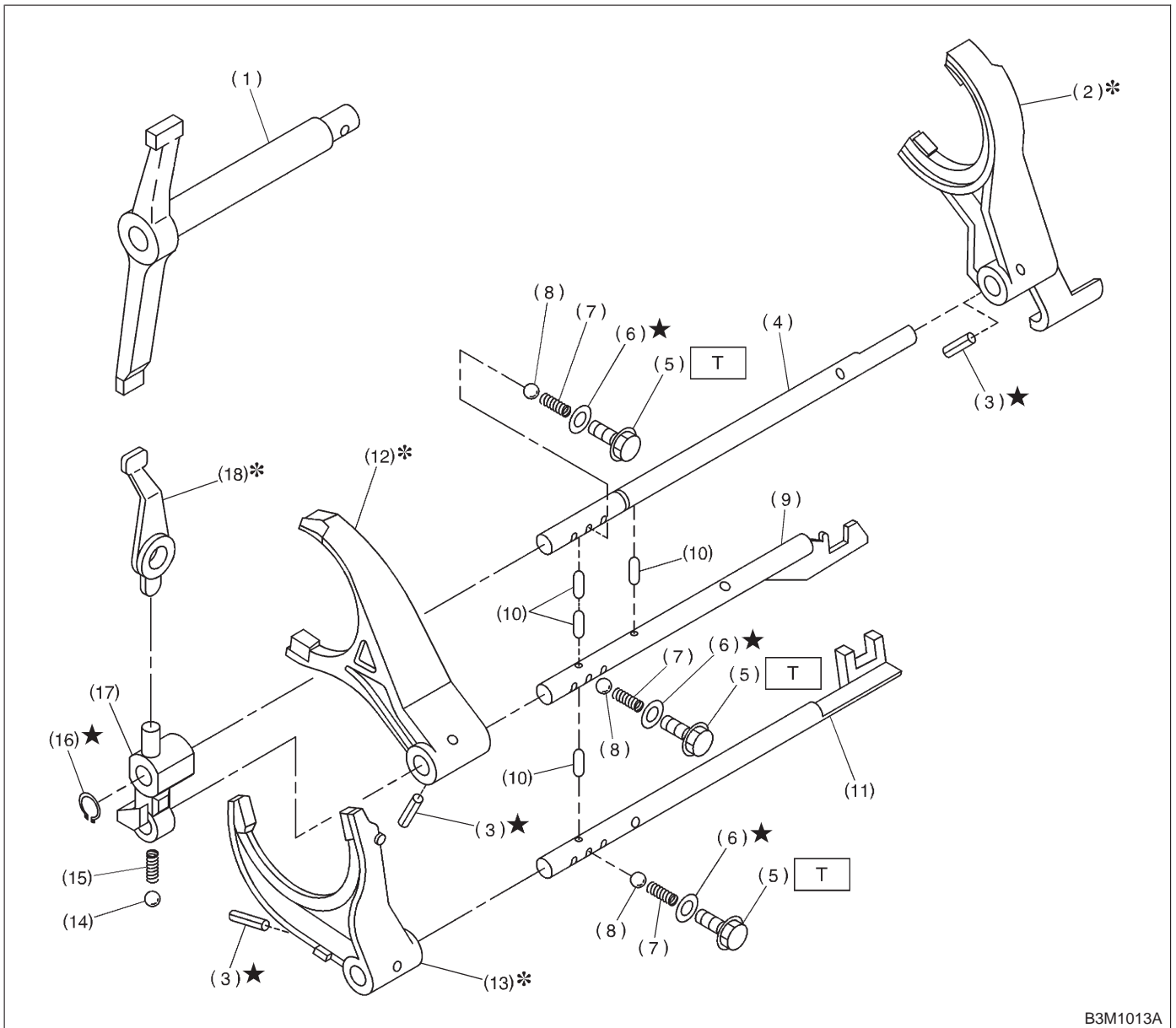

B3M1013A

- | | | |
|--------------------------|----------------------------|----------------------------|
| (1) Shifter arm | (9) 3rd-4th fork rod | (17) Reverse fork rod arm |
| (2) 5th shifter fork | (10) Interlock plunger | (18) Reverse shifter lever |
| (3) Straight pin | (11) 1st-2nd fork rod | |
| (4) Reverse fork rod | (12)* 3rd-4th shifter fork | |
| (5) Checking ball plug | (13)* 1st-2nd shifter fork | |
| (6) Gasket | (14) Ball | |
| (7) Checking ball spring | (15) Spring | |
| (8) Ball | (16)* Snap ring (Outer) | |

Tightening torque: N-m (kg-m, ft-lb)
T: 19.6±1.5 (2.00±0.15, 14.5±1.1)

5. Transfer Case and Extension

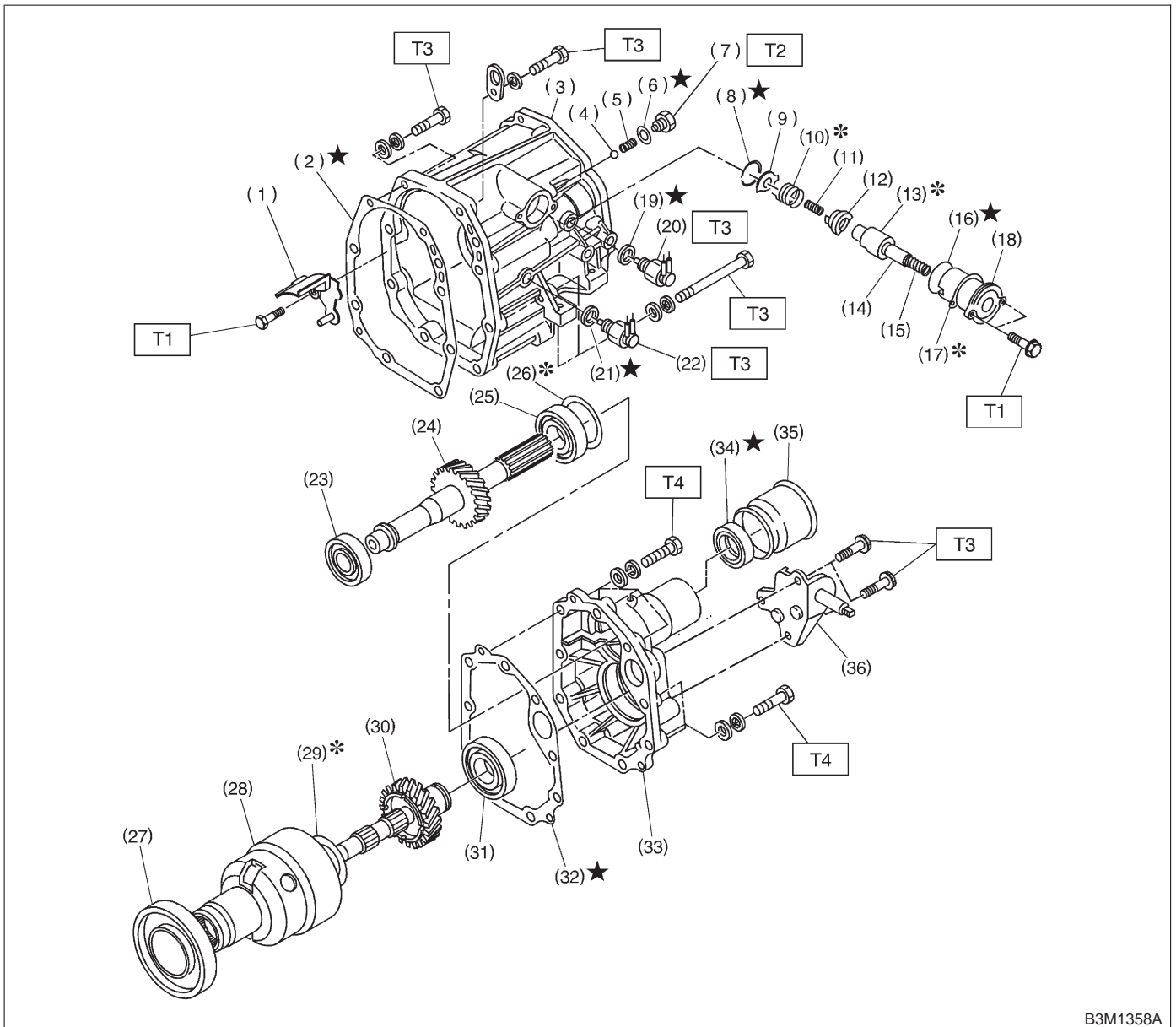

B3M1358A

- | | | |
|----------------------------|----------------------------|--------------------|
| (1) Oil guide | (16) O-ring | (31) Ball bearing |
| (2) Gasket | (17) Adjusting select shim | (32) Gasket |
| (3) Transfer case | (18) Reverse check sleeve | (33) Extension |
| (4) Ball | (19) Gasket | (34) Oil seal |
| (5) Reverse accent spring | (20) Neutral switch | (35) Dust cover |
| (6) Gasket | (21) Gasket | (36) Shift bracket |
| (7) Plug | (22) Back-up light switch | |
| (8) Snap ring (Inner) | (23) Ball bearing | |
| (9) Reverse check plate | (24) Adjusting washer | |
| (10) Reverse check spring | (25) Ball bearing | |
| (11) Reverse return spring | (26) Adjusting washer | |
| (12) Reverse check cam | (27) Ball bearing | |
| (13) Reverse accent shaft | (28) Center differential | |
| (14) Return spring cap | (29) Adjusting washer | |
| (15) Return spring | (30) Transfer drive gear | |

Tightening torque: N-m (kg-m, ft-lb)

T1: 5±1 (0.5±0.1, 3.6±0.7)

T2: 10±1 (1.0±0.1, 7.2±0.7)

T4: 25±2 (2.5±0.2, 18.1±1.4)

T4: 37±3 (3.8±0.3, 27.5±2.2)

6. Front Differential

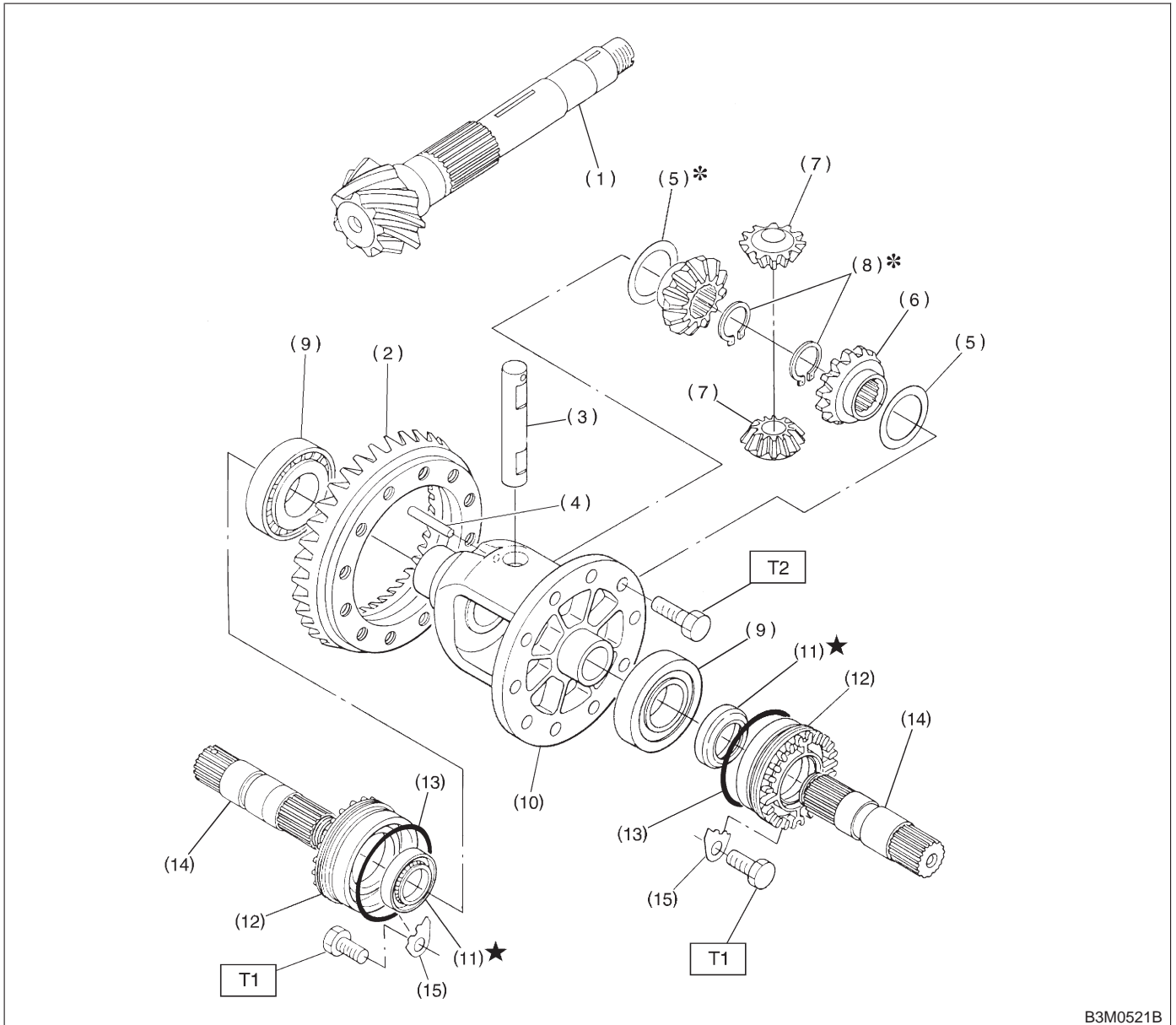

B3M0521B

- | | |
|-------------------------------|---------------------------------|
| (1) Drive pinion shaft | (8) Snap ring (Outer) |
| (2) Hypoid driven gear | (9) Roller bearing |
| (3) Pinion shaft | (10) Differential case |
| (4) Straight pin | (11) Oil seal |
| (5) Washer | (12) Differential side retainer |
| (6) Differential bevel gear | (13) O-ring |
| (7) Differential bevel pinion | (14) Axle drive shaft |

- (15) Retainer lock plate

Tightening torque: N-m (kg-m, ft-lb)

T1: 25±5 (2.5±0.5, 18.1±3.6)

T2: 62±5 (6.3±0.5, 45.6±3.6)

1. General

A: PRECAUTIONS

- 1) Clean oil, grease, dirt and dust from transmission.
- 2) Remove drain plug to drain oil. After draining, retighten it as before.

CAUTION:

Replace gasket with a new one.

Tightening torque:

44±3 N·m (4.5±0.3 kg·m, 32.5±2.2 ft·lb)

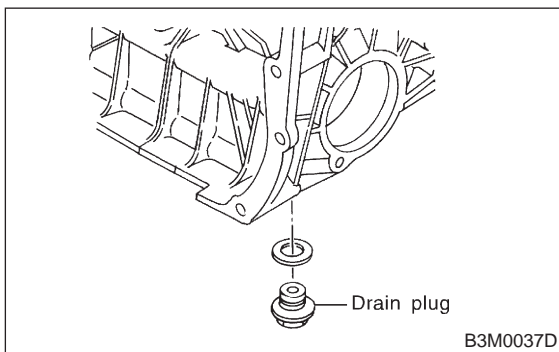

- 3) Attach transmission to ST.
ST 499937100 TRANSMISSION STAND SET

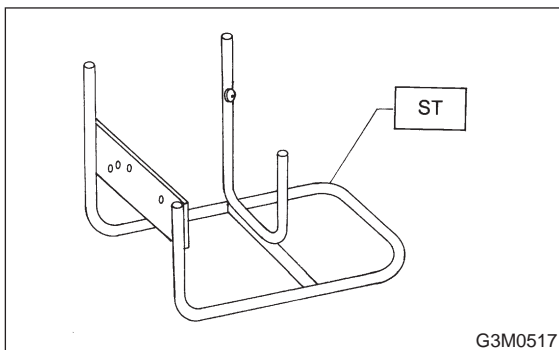

- 4) Rotating parts should be coated with oil prior to assembly.
- 5) All disassembled parts, if to be reused, should be reinstalled in the original positions and directions.
- 6) Gaskets and lock washers must be replaced with new ones.
- 7) Liquid gasket should be used where specified to prevent leakage.
- 8) Fill transmission gear oil through the oil level gauge hole up to upper point level gauge. <Ref. to 1-5 [G9A1].>

B: INSPECTION

Disassembled parts should be washed clean first and then inspected carefully.

- 1) Bearings

Replace bearings in the following cases:

- Bearings whose balls, outer races and inner races are broken or rusty.
- Worn bearings
- Bearings that fail to turn smoothly or make abnormal noise when turned after gear oil lubrication.
- The ball bearing on the rear side of the drive pinion shaft should be checked for smooth rotation before the drive pinion assembly is disassembled. In this case, because a preload is working on the bearing, its rotation feels like it is slightly dragging unlike the other bearings.

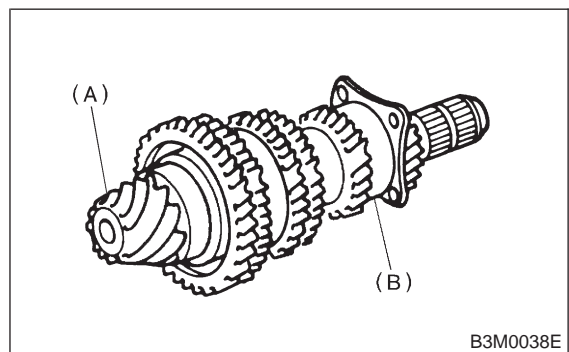

- (A) Drive pinion shaft
- (B) Ball bearing

- Bearings having other defects
- 2) Bushing (each gear)
Replace the bushing in the following cases:
 - When the sliding surface is damaged or abnormally worn.
 - When the inner wall is abnormally worn.
 - 3) Gears
 - Replace gears with new ones if their tooth surfaces are broken, damaged, or excessively worn.
 - Correct or replace if the cone that contacts the baulk ring is rough or damaged.
 - Correct or replace if the inner surface or end face is damaged.
 - 4) Baulk ring
Replace the ring in the following cases:
 - When the inner surface and end face are damaged.
 - When the ring inner surface is abnormally or partially worn down.

3-1 [W1B0]

1. General

SERVICE PROCEDURE

- If the gap between the end faces of the ring and the gear splined part is excessively small when the ring is pressed against the cone.

Clearance (A):

0.5 — 1.0 mm (0.020 — 0.040 in)

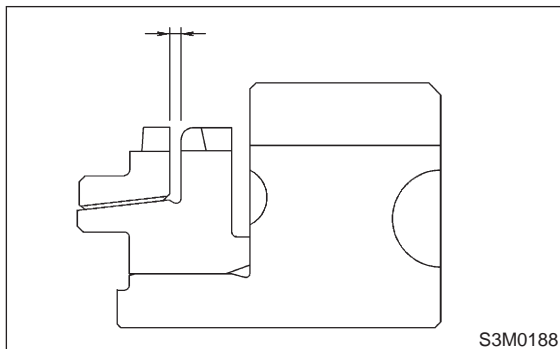

- When the contact surface of the synchronizer ring insert is scored or abnormally worn down.

5) Shifting insert

Replace the insert if deformed, excessively worn, or defective in any way.

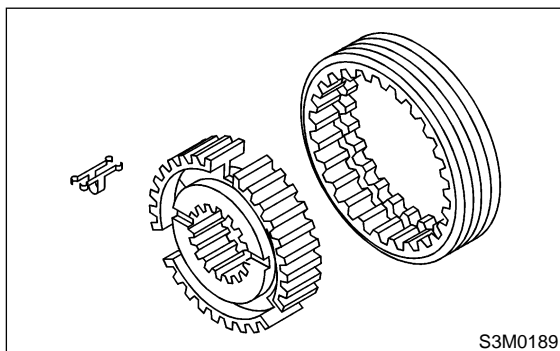

6) Oil seal

Replace the oil seal if the lip is deformed, hardened, damaged, worn, or defective in any way.

7) O-ring

Replace the O-ring if the sealing face is deformed, hardened, damaged, worn, or defective in any way.

8) Gearshift mechanism

Repair or replace the gearshift mechanism if excessively worn, bent, or defective in any way.

9) Differential gear

Repair or replace the differential gear in the following cases:

- The hypoid drive gear and drive pinion shaft tooth surface are damaged, excessively worn, or seized.
- The roller bearing on the drive pinion shaft has a worn or damaged roller path.
- There is damage, wear, or seizure of the differential bevel pinion, differential bevel gear, washer, pinion shaft, and straight pin.
- The differential case has worn or damaged sliding surfaces.

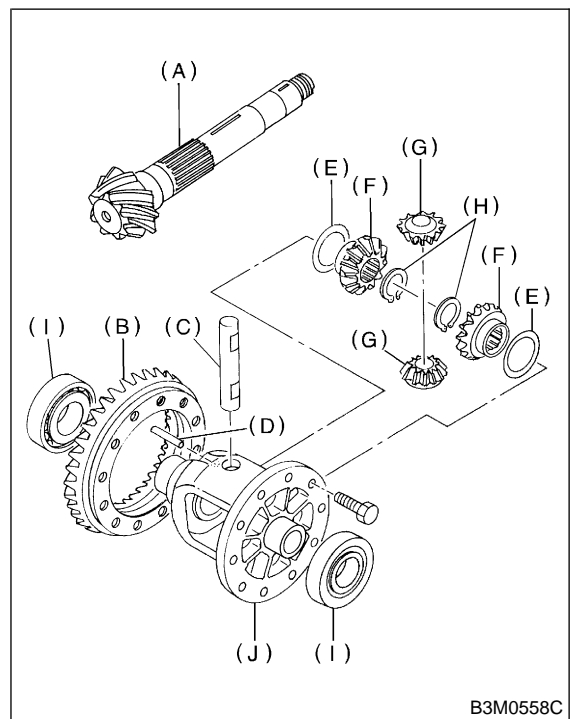

- (A) Drive pinion shaft
- (B) Hypoid driven gear
- (C) Pinion shaft
- (D) Straight pin
- (E) Washer
- (F) Differential bevel gear
- (G) Differential bevel pinion
- (H) Snap ring
- (I) Roller bearing
- (J) Differential case

2. Transmission Case

A: DISASSEMBLY

1. SEPARATION OF TRANSMISSION

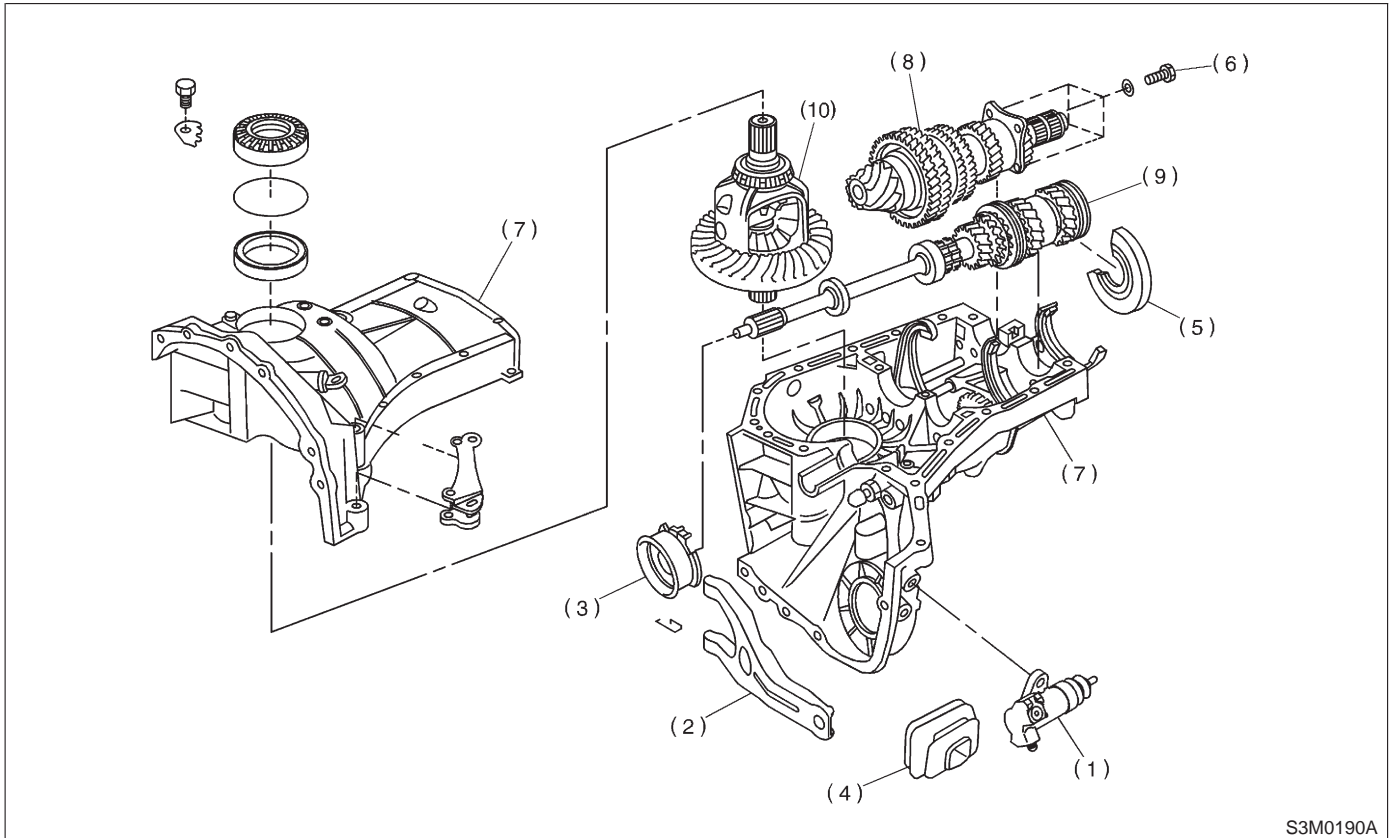

S3M0190A

- | | | |
|---------------------------|---------------------------|-------------------------|
| (1) Operating cylinder | (5) Bolt | (9) Main shaft ASSY |
| (2) Release lever | (6) Main shaft rear plate | (10) Front differential |
| (3) Release bearing | (7) Transmission case | |
| (4) Release lever sealing | (8) Drive pinion ASSY | |

1) Remove clutch release lever. <Ref. to 2-10 [W3A0].>

3) Remove bearing mounting bolts.

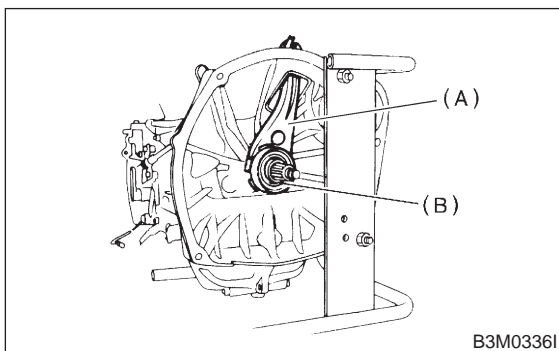

B3M0336I

- (A) Clutch release lever
(B) Release bearing

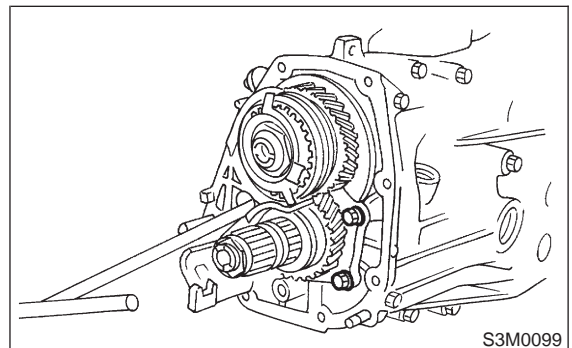

S3M0099

2) Remove transfer case assembly. <Ref. to 3-1 [W5A0].>

3-1 [W2A1]

2. Transmission Case

SERVICE PROCEDURE

4) Remove main shaft rear plate.

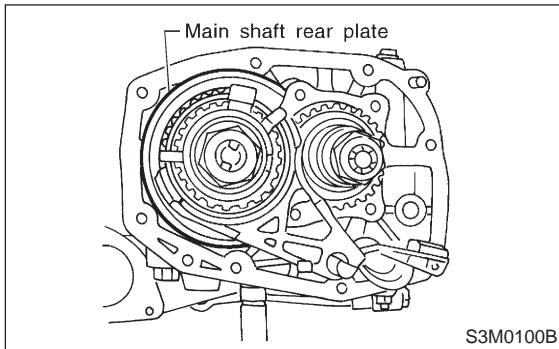

5) Put vinyl tape around splines of right and left axle drive shafts to prevent damage to oil seals.

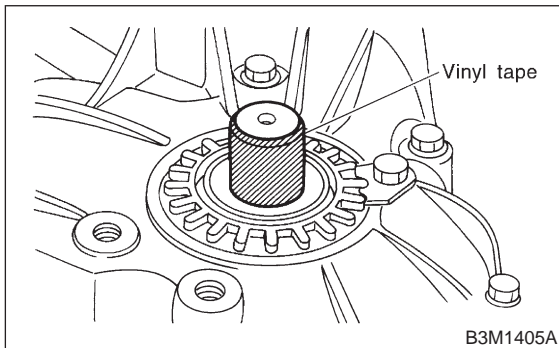

6) Separate transmission case into right and left cases by loosening seventeen coupling bolts and nuts.

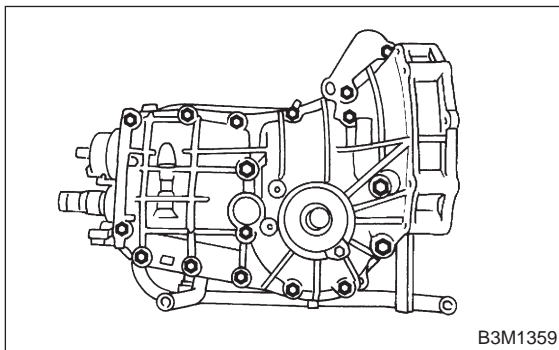

7) Remove drive pinion shaft assembly from left side transmission case.

NOTE:

Use a hammer handle, etc. to remove if too tight.

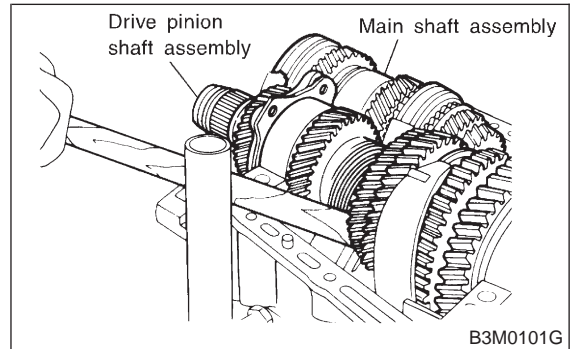

8) Remove main shaft assembly.

9) Remove differential assembly.

CAUTION:

- Be careful not to confuse right and left roller bearing outer races.
- Be careful not to damage retainer oil seal.

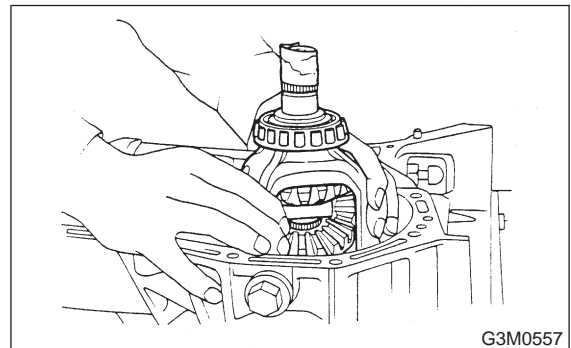

2. TRANSMISSION CASE

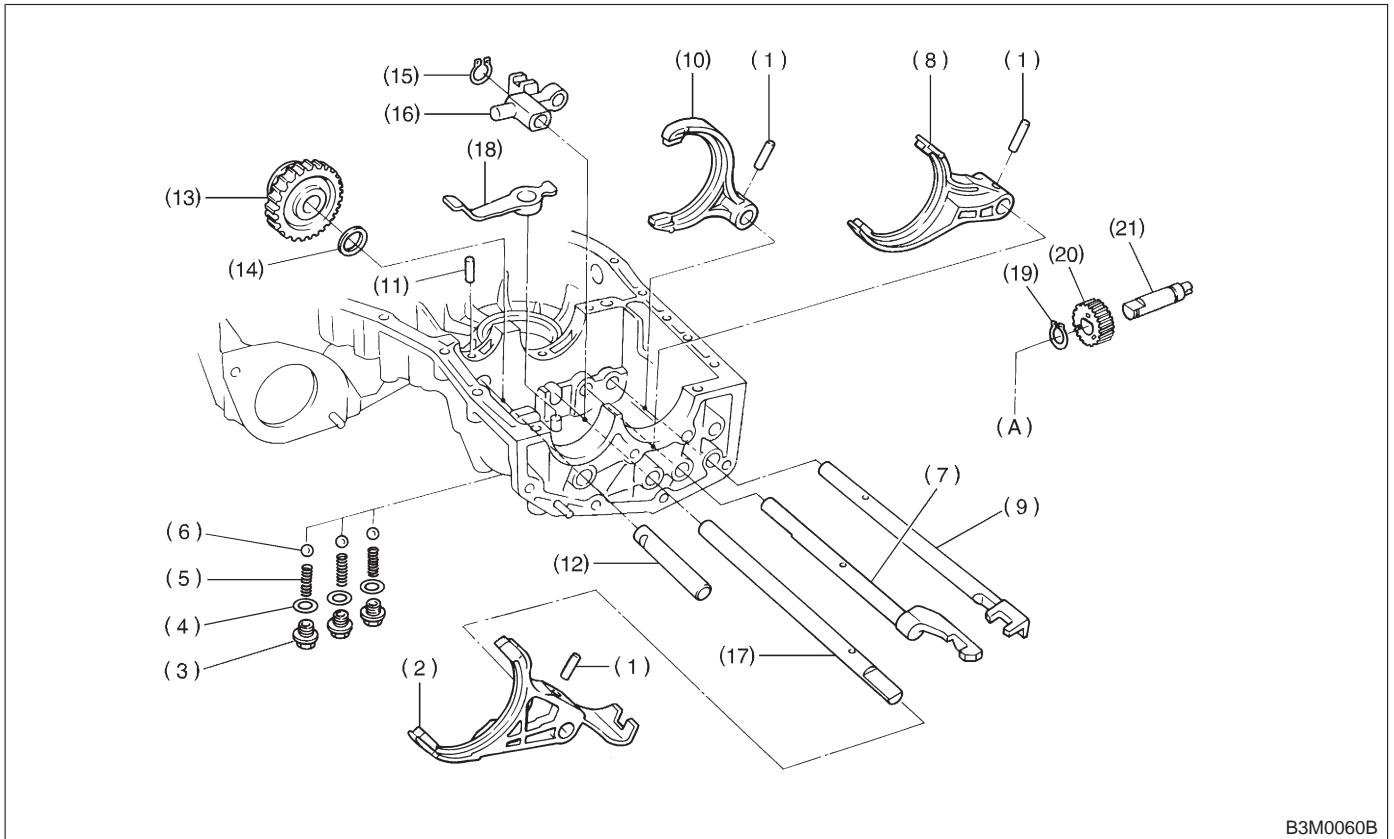

B3M0060B

- | | | |
|--------------------------|-------------------------------|--|
| (1) Straight pin | (9) 1st-2nd fork rod | (17) Reverse fork rod |
| (2) 5th shifter fork | (10) 1st-2nd shifter fork | (18) Reverse shifter lever |
| (3) Checking ball plug | (11) Straight pin | (19) Snap ring (RH side) |
| (4) Gasket | (12) Reverse idler gear shaft | (20) Speedometer driven gear (RH side) |
| (5) Checking ball spring | (13) Reverse idler gear | (21) Speedometer shaft (RH side) |
| (6) Ball | (14) Washer | (A) Front right hand transmission case |
| (7) 3rd-4th fork rod | (15) Snap ring | |
| (8) 3rd-4th shifter fork | (16) Reverse fork rod arm | |

1) Drive out straight pin with ST, and remove 5th shifter fork.

ST 398791700 STRAIGHT PIN REMOVER

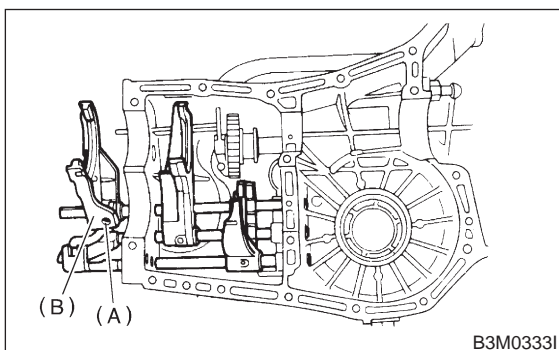

- (A) Straight pin
(B) 5th shifter fork

2) Remove plugs, springs and checking balls.

3-1 [W2A2]

2. Transmission Case

SERVICE PROCEDURE

3) Drive out straight pin, and pull out 3-4 fork rod and shifter fork.

NOTE:

When removing rod, keep other rods in neutral. Also, when pulling out straight pin, remove it toward inside of case so that it may not hit against case.

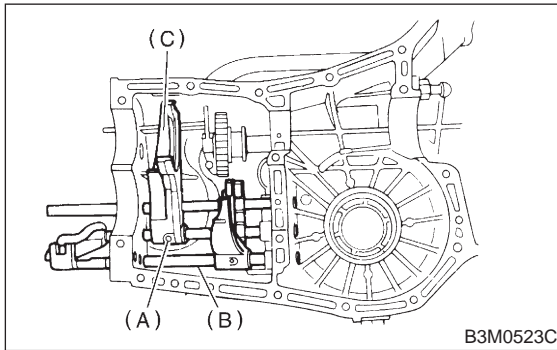

- (A) Straight pin
- (B) 3-4 fork rod
- (C) Shifter fork

4) Drive out straight pin, and pull out 1-2 fork rod and shifter fork.

5) Pull out straight pin, and remove idler gear shaft, reverse idler gear and washer.

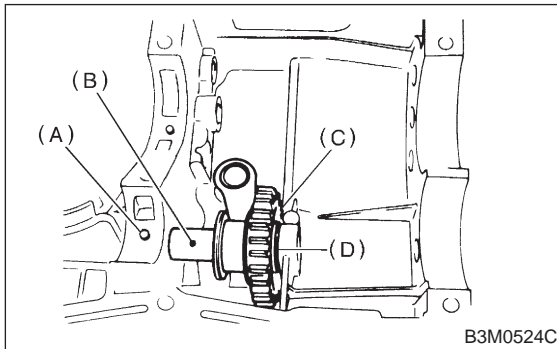

- (A) Straight pin
- (B) Idler gear shaft
- (C) Idler gear
- (D) Washer

6) Remove outer snap ring, and pull out reverse shifter rod arm from reverse fork rod. Then take out ball, spring and interlock plunger from rod. And then remove rod.

NOTE:

When pulling out reverse shifter rod arm, be careful not to let ball pop out of arm.

7) Remove reverse shifter lever.

8) Remove differential side retainers using ST. ST 499787000 WRENCH ASSY

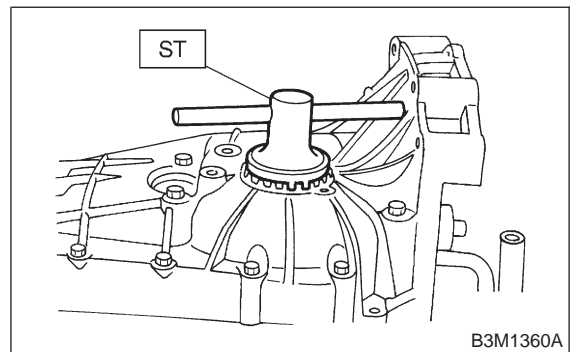

9) Remove outer snap ring and pull out speedometer driven gear. Next, remove vehicle speed sensor 2, oil seal, speedometer shaft and washer.

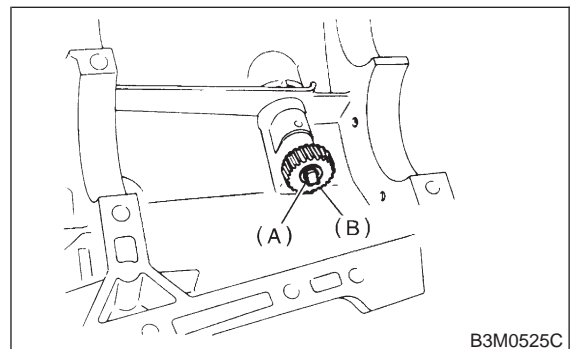

- (A) Outer snap ring
- (B) Speedometer driven gear

B: ASSEMBLY

1. TRANSMISSION CASE

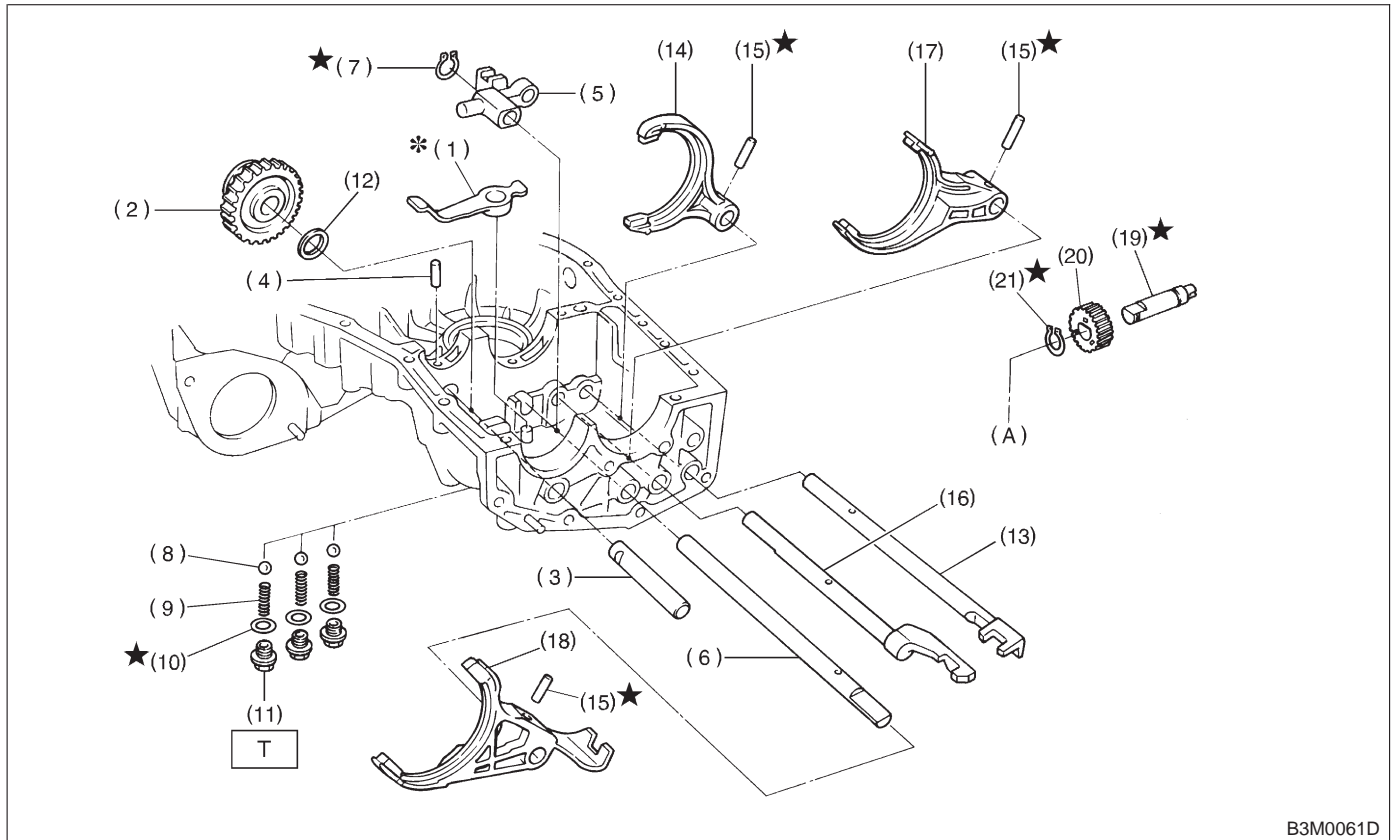

B3M0061D

- | | | |
|------------------------------|---------------------------|-------------------------------------|
| (1) Reverse shifter lever | (10) Washer | (19) Speedometer shaft |
| (2) Reverse idler gear | (11) Checking ball plug | (20) Speedometer driven gear |
| (3) Reverse idler gear shaft | (12) Washer | (21) Snap ring |
| (4) Straight pin | (13) 1st-2nd fork rod | (A) To right hand transmission case |
| (5) Reverse fork rod arm | (14) 1st-2nd shifter fork | |
| (6) Reverse fork rod | (15) Straight pin | |
| (7) Snap ring | (16) 3rd-4th fork rod | |
| (8) Ball | (17) 3rd-4th shifter fork | |
| (9) Checking ball spring | (18) 5th shifter fork | |

Tightening torque: N-m (kg-m, ft-lb)

**T: 19.6±0.1
(2.00±0.015, 14.5±0.1)**

1) Position interlock plungers (5.56 × 19.6), one plunger in hole between 1-2 and 3-4 fork rod holes, and one plunger in hole between 3-4 and reverse fork rod holes.

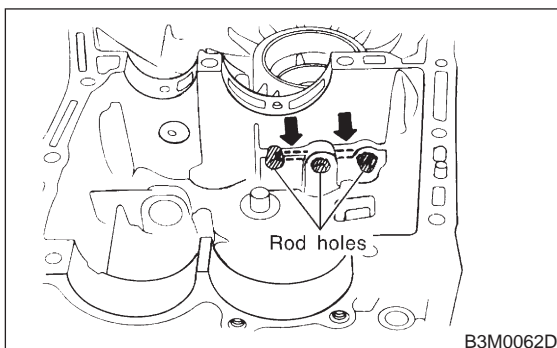

B3M0062D

3-1 [W2B1]

2. Transmission Case

SERVICE PROCEDURE

2) Install reverse shifter lever, reverse idler gear and reverse idler gear shaft, and secure with straight pin.

NOTE:

Be sure to install reverse idler shaft from the rear side.

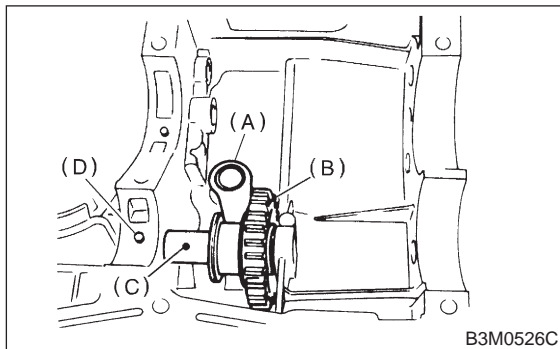

- (A) Reverse shifter lever
- (B) Reverse idler gear
- (C) Reverse idler gear shaft
- (D) Straight pin

3) Install reverse arm fork spring, ball and interlock plunger (5.56 × 19.6) to reverse fork rod arm. Insert reverse fork rod into hole in reverse fork rod arm, and hold it with outer snap ring using ST.

CAUTION:

Apply grease to plunger to prevent it from falling.

ST 399411700 ACCENT BALL INSTALLER

4) Position ball (7.1438), spring and gasket in reverse shifter rod hole, on left side transmission case, and tighten checking ball plug.

CAUTION:

Replace gasket with a new one.

5) Move reverse shifter rod toward REV side. Adjust clearance between reverse idler gear and transmission case wall, using reverse shifter lever.

Clearance A:

6.0 — 7.5 mm (0.236 — 0.295 in)

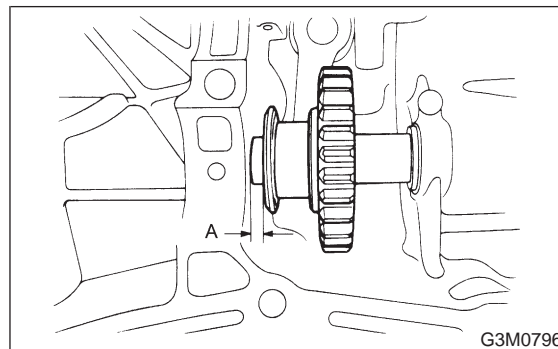

Reverse shifter lever		
Part No.	No.	Remarks
32820AA070	7	Further from case wall
32820AA080	8	Standard
32820AA090	9	Closer to case wall

6) After installing a suitable reverse shifter lever, shift into neutral. Using a thickness gauge, measure clearance between reverse idler gear and transmission case wall and adjust with washer(s).

Clearance:

0 — 0.5 mm (0 — 0.020 in)

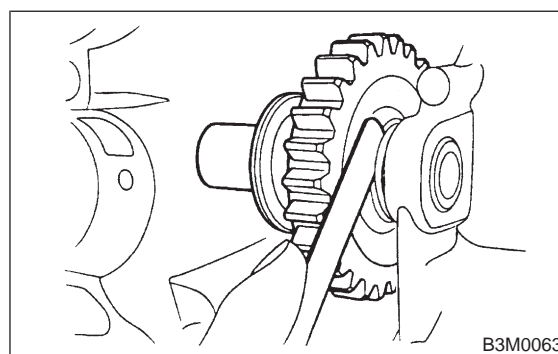

Washer (20.5 × 26 × t)	
Part No.	Thickness mm (in)
803020151	0.4 (0.016)
803020152	1.1 (0.043)
803020153	1.5 (0.059)
803020154	1.9 (0.075)
803020155	2.3 (0.091)

7) Install 1-2 fork rod into 1-2 shifter fork via the hole on the rear of transmission case.

8) Align the holes in rod and fork, and drive straight pin (6 × 22) into these holes using ST.

ST 398791700 STRAIGHT PIN REMOVER

CAUTION:
Replace straight pin with a new one.

NOTE:

- Set other rods to neutral.
- Make sure interlock plunger (5.56 × 19.6) is on the 3-4 fork rod side.

9) Install interlock plunger (3 × 11.9) onto 3-4 fork rod.

CAUTION:
Apply a coat of grease to plunger to prevent it from falling.

10) Install 3-4 fork rod into 3-4 shifter fork via the hole on the rear of transmission case.

11) Align the holes in rod and fork, and drive straight pin (6 × 22) into these holes.

ST 398791700 STRAIGHT PIN REMOVER

CAUTION:
Replace straight pin with a new one.

NOTE:

- Set reverse fork rod to neutral.
- Make sure interlock plunger (installed before) is on the reverse fork rod side.

12) Install 5th shifter fork onto the rear of reverse fork rod. Align holes in the two parts and drive straight pin into place.

CAUTION:
Replace straight pin with a new one.

ST 398791700 STRAIGHT PIN REMOVER

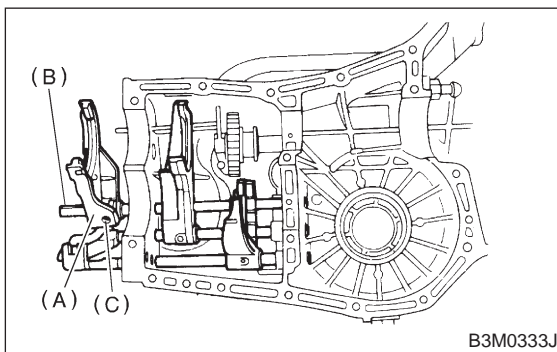

- (A) 5th shifter fork
- (B) Reverse fork rod
- (C) Straight pin

13) Position balls, checking ball springs and gas-kets into 3-4 and 1-2 rod holes, and install plugs.

CAUTION:
Replace gasket with a new one.

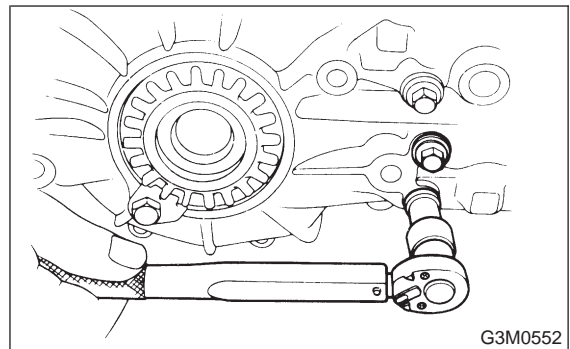

14) Install washer and speedometer shaft, and press fit oil seal with ST.

CAUTION:
Use new oil seal, if it has been removed.

ST 899824100 or 499827000 PRESS

15) Install vehicle speed sensor 2.

CAUTION:
Use new vehicle speed sensor 2, if it has been removed.

Tightening torque:
 $5.9 \pm 1.5 \text{ N-m}$ ($60 \pm 15 \text{ kg-cm}$, $52 \pm 13 \text{ in-lb}$)

16) Install speedometer driven gear and snap ring.

CAUTION:
Use a new snap ring, if it has been removed.

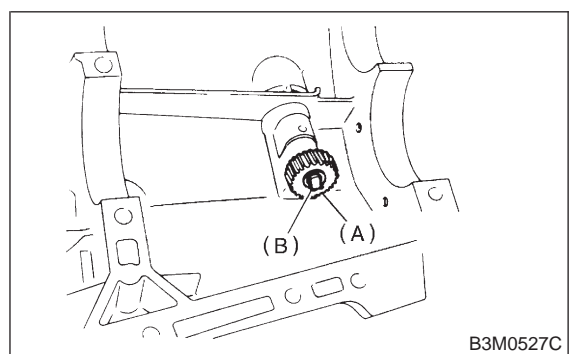

- (A) Speedometer driven gear
- (B) Snap ring

2. COMBINATION OF TRANSMISSION CASE

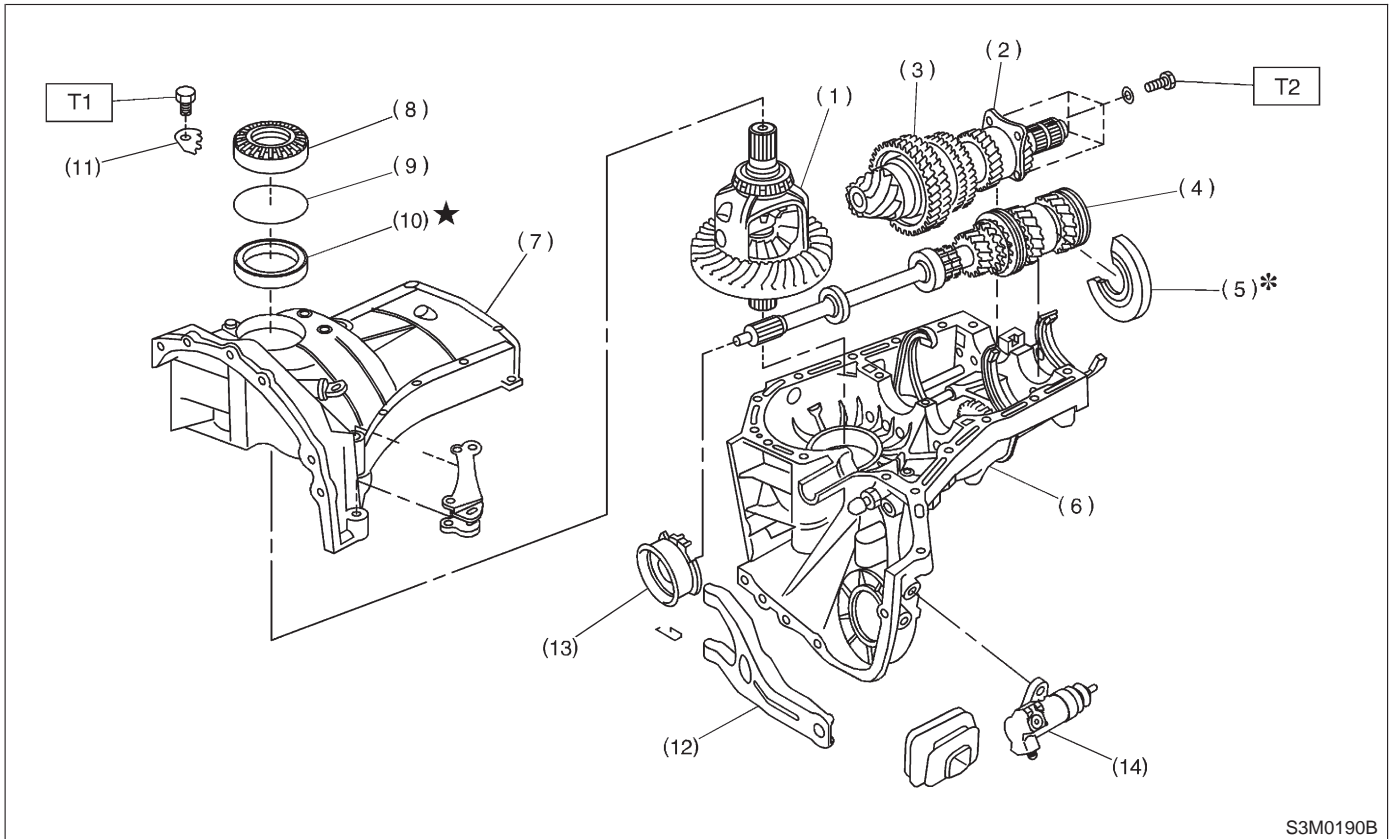

S3M0190B

- | | | |
|----------------------------|--------------------------------|---|
| (1) Differential ASSY | (8) Differential side retainer | (14) Operating cylinder (2500 cc model) |
| (2) Drive pinion shim | (9) O-ring | |
| (3) Drive pinion ASSY | (10) Oil seal | |
| (4) Main shaft ASSY | (11) Retainer lock plate | |
| (5) Main shaft rear plate | (12) Release lever | |
| (6) Transmission case (LH) | (13) Release bearing | |
| (7) Transmission case (RH) | | |

Tightening torque: N·m (kg·m, ft·lb)

T1: 25 (2.5, 18)

T2: 29±3 (3.0±0.3, 21.7±2.2)

1) Alignment marks/numbers on hypoid gear set
 The upper number on driven pinion is the match number for combining it with hypoid driven gear. The lower number is for shim adjustment. If no lower number is shown, the value is zero. The number on hypoid driven gear indicates a number for combination with drive pinion.

2) Place drive pinion shaft assembly on right hand transmission main case without shim and tighten bearing mounting bolts.

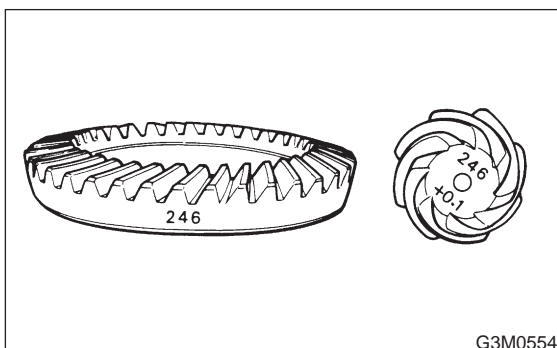

G3M0554

3) Inspection and adjustment of ST

NOTE:

- Loosen the two bolts and adjust so that the scale indicates 0.5 correctly when the plate end and the scale end are on the same level.
- Tighten the two bolts.

ST 499917500 DRIVE PINION GAUGE ASSY

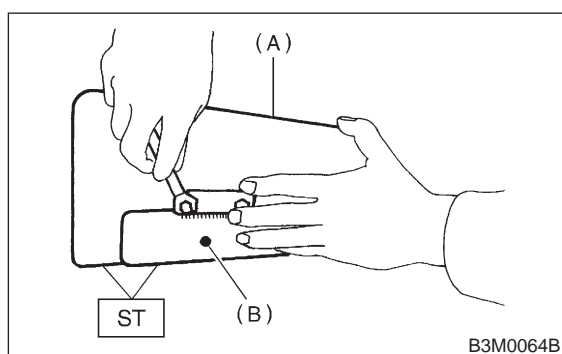

- (A) Plate
(B) Scale

4) Position the ST by inserting the knock pin of ST into the knock hole in the transmission case.

ST 499917500 DRIVE PINION GAUGE ASSY

5) Slide the drive pinion gauge scale with finger tip and read the value at the point where it matches with the end face of drive pinion.

ST 499917500 DRIVE PINION GAUGE ASSY

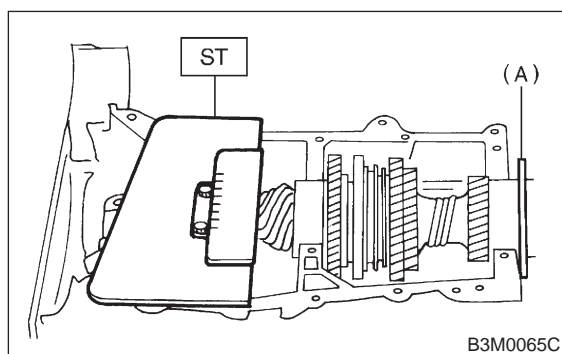

- (A) Adjust clearance to zero without shim.

6) The thickness of shim shall be determined by adding the value indicated on drive pinion to the value indicated on the ST. (Add if the number on drive pinion is prefixed by + and subtract if the number is prefixed by -.)

ST 499917500 DRIVE PINION GAUGE ASSY

7) Select one to three shims from the next table for the value determined as described above and take a shim thickness which is closest to the said value.

Drive pinion shim	
Part No.	Thickness mm (in)
32295AA031	0.150 (0.0059)
32295AA041	0.175 (0.0069)
32295AA051	0.200 (0.0079)
32295AA061	0.225 (0.0089)
32295AA071	0.250 (0.0098)
32295AA081	0.275 (0.0108)
32295AA091	0.300 (0.0118)
32295AA101	0.500 (0.0197)

8) Install differential assembly on left hand transmission case.

CAUTION:

Be careful not to fold the sealing lip of oil seal.

NOTE:

Wrap the left and right splined sections of axle shaft with vinyl tape to prevent scratches.

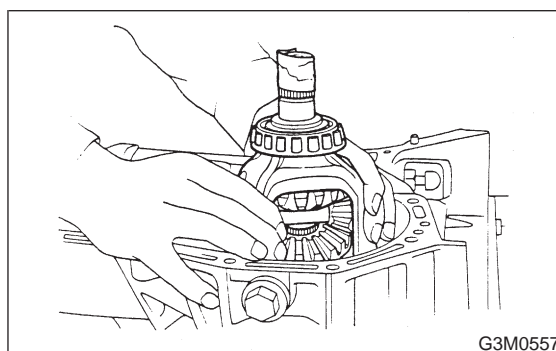

9) Install needle bearing and oil seal onto the front of transmission main shaft assembly, and position in left side transmission case.

CAUTION:

- Wrap clutch splined section with vinyl tape to prevent damage to oil seal.
- Apply grease (Unilube #2 or equivalent) to the sealing lip of oil seal.
- Use a new oil seal.

3-1 [W2B2]

2. Transmission Case

SERVICE PROCEDURE

NOTE:

- Align the end face of seal with surface A of left side transmission main case when installing oil seal.

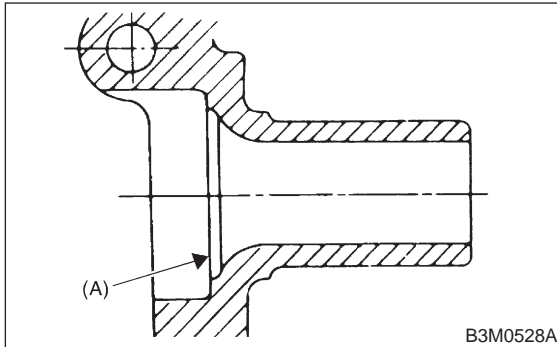

- Be careful not to drop oil seal when installing right side transmission main case.
- Make sure straight pin is positioned in hole in needle bearing's outer race.

10) Install drive pinion shaft assembly with shims selected before into transmission case.

NOTE:

Ensure that the knock pin of the case is fitted into the hole in the bearing outer race.

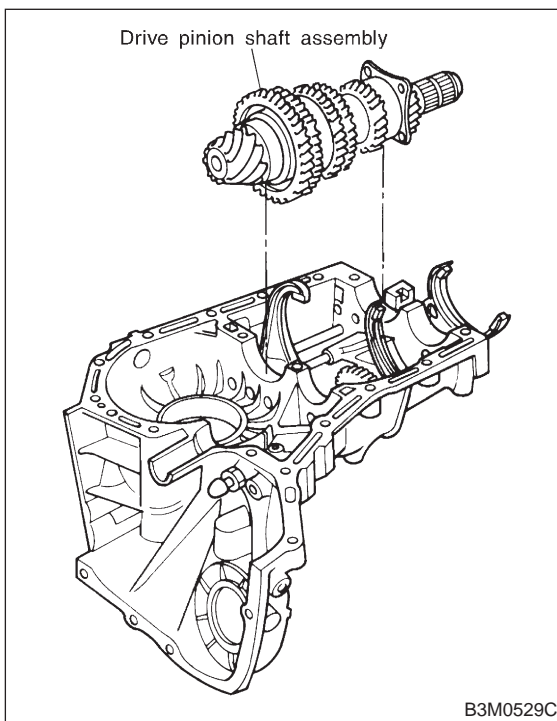

11) Set transmission main shaft assembly and drive pinion shaft assembly in position (so there is no clearance between the two when moved all the way to the front). Select suitable 1st-2nd, 3rd-4th and 5th shifter fork so that coupling sleeve and reverse driven gear are positioned in the center of their synchronizing mechanisms.

1st driven gear to reverse driven gear

Clearance (a): 9.5 mm (0.374 in)

Reverse driven gear to 2nd driven gear

Clearance (b): 9.5 mm (0.374 in)

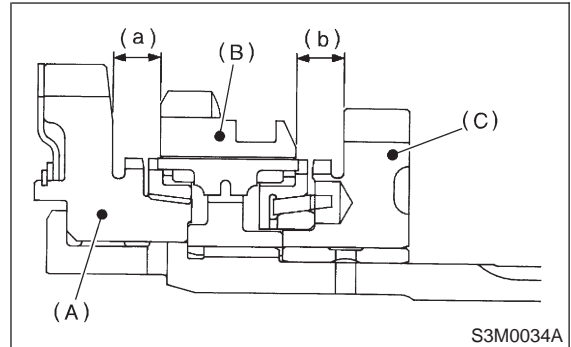

- (A) 1st driven gear
- (B) Reverse driven gear
- (C) 2nd driven gear

1st-2nd shifter fork		
Part No.	No.	Remarks
32804AA060	1	Approach to 1st gear by 0.2 mm (0.008 in)
32804AA070	No mark	Standard
32804AA080	3	Approach to 2nd gear by 0.2 mm (0.008 in)

3rd-4th gear to coupling sleeve

Clearance (a): 9.3 mm (0.366 in)

Coupling sleeve to 4th driven gear

Clearance (b): 9.3 mm (0.366 in)

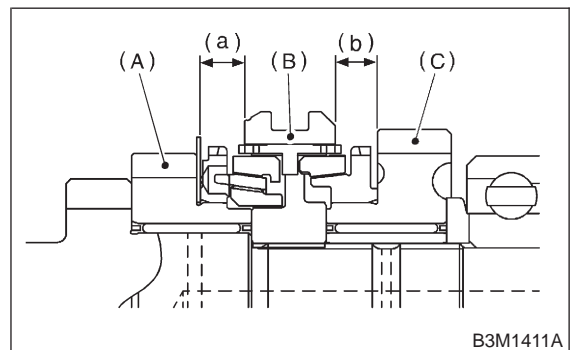

- (A) 3rd-4th
- (B) Coupling sleeve
- (C) 4th driven gear

3rd-4th shifter fork		
Part No.	No.	Remarks
32810AA061	1	Approach to 4th gear by 0.2 mm (0.008 in)
32810AA071	No mark	Standard
32810AA101	3	Approach to 3rd gear by 0.2 mm (0.008 in)

5th driven gear to coupling sleeve
Clearance (a): 9.3 mm (0.366 in)

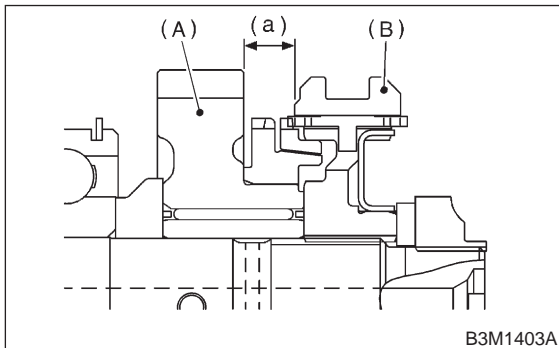

- (A) 5th driven gear
- (B) Coupling sleeve

5th shifter fork		
Part No.	No.	Remarks
32812AA200	4	Approach to 5th gear by 0.2 mm (0.008 in)
32812AA210	No mark	Standard
32812AA220	6	Become distant from 5th gear by 0.2 mm (0.008 in)

12) Measure rod end clearances (A) and (B). If any clearance is not within specifications, replace rod or fork as required.

(A): 1st-2nd to 3rd-4th	0.4 — 1.4 mm (0.016 — 0.055 in)
(B): 3rd-4th to 5th	0.5 — 1.3 mm (0.020 — 0.051 in)

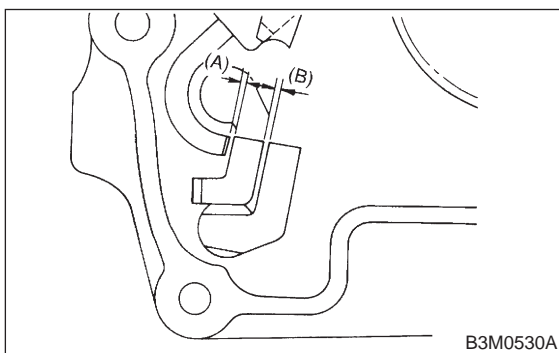

13) Wipe off grease, oil and dust on the mating surfaces of transmission cases with white gasoline, and apply liquid gasket, and then put case right side and left side together.

Liquid gasket:
THREE BOND 1215 or equivalent

14) Tighten 17 bolts with bracket, clip, etc. as shown in the figure.

NOTE:

- Insert bolts from the bottom and tighten nuts at the top.
- Put cases together so that drive pinion shim and input shaft holder shim are not caught up in between.
- Confirm that speedometer gear is meshed.

Tightening torque:

8 mm bolt

25±2 N·m (2.5±0.2 kg·m, 18.1±1.4 ft-lb)

★ 10 mm bolt

39±3 N·m (4.0±0.3 kg·m, 28.9±2.2 ft-lb)

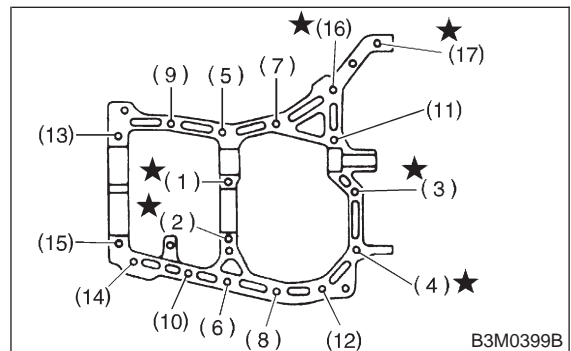

15) Tighten ball bearing attachment bolts.

Tightening torque:

29±3 N·m (3.0±0.3 kg·m, 21.7±2.2 ft-lb)

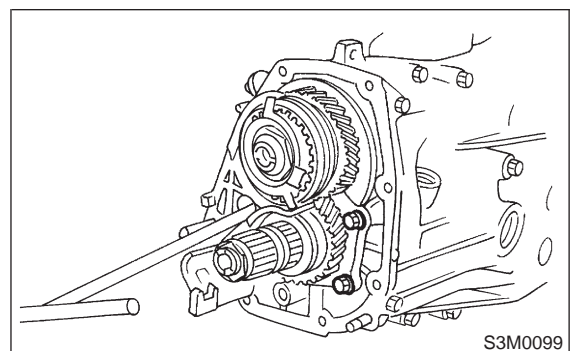

3-1 [W2B2]

2. Transmission Case

SERVICE PROCEDURE

16) Backlash adjustment of hypoid gear and pre-load adjustment of roller bearing

NOTE:

Support drive pinion assembly with ST.

ST 498427100 STOPPER

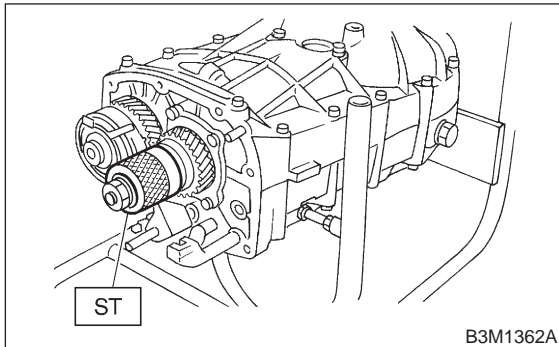

17) Place the transmission with case left side facing downward and put ST1 on bearing cup.

18) Screw retainer assembly into left case from the bottom with ST2. Fit ST3 on the transmission main shaft. Shift gear into 4th or 5th and turn the shaft several times. Screw in the retainer while turning ST3 until a slight resistance is felt on ST2. This is the contact point of hypoid gear and drive pinion shaft. Repeat the above sequence several times to ensure the contact point.

ST1 399780104 WEIGHT

ST2 499787000 WRENCH ASSY

ST3 499927100 HANDLE

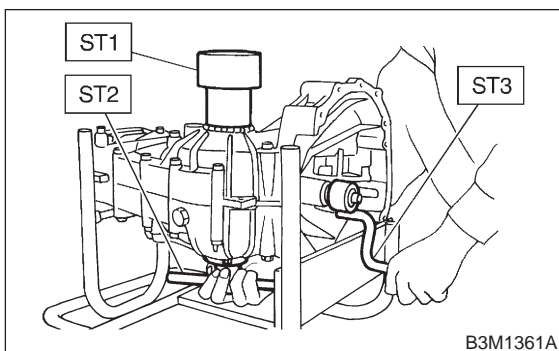

19) Remove weight and screw in retainer without O-ring on the upper side and stop at the point where slight resistance is felt.

NOTE:

At this point, the backlash between the hypoid gear and drive pinion shaft is zero.

ST 499787000 WRENCH ASSY

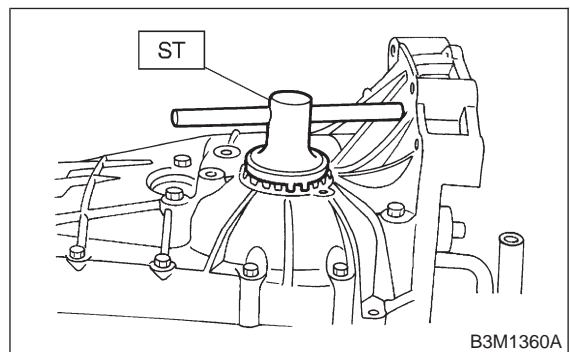

20) Fit lock plate. Loosen the retainer on the lower side by 1-1/2 notches of lock plate and turn in the retainer on the upper side by the same amount in order to obtain the backlash.

NOTE:

The notch on the lock plate moves by 1/2 notch if the plate is turned upside down.

21) Turn in the retainer on the upper side additionally by 1 notch in order to apply preload on taper roller bearing.

22) Tighten temporarily both the upper and lower lock plates and mark both holder and lock plate for later readjustment.

23) Turn transmission main shaft several times while tapping around retainer lightly with plastic hammer.

24) Set ST1 and ST2. Insert the needle through transmission oil drain plug hole so that the needle comes in contact with the tooth surface at a right angle and check the backlash.

ST1 498247001 MAGNET BASE
ST2 498247100 DIAL GAUGE
ST3 498255400 PLATE

NOTE:

- If backlash is outside specified range, adjust it by turning holder in right side case.
- Each time holder rotates one tooth, backlash changes by 0.05 mm (0.0020 in).

Backlash:

0.13 — 0.18 mm (0.0051 — 0.0071 in)

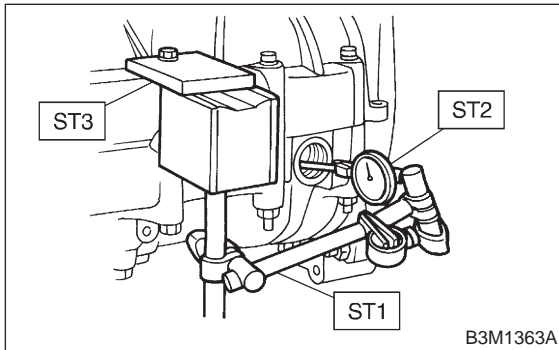

25) Check tooth contact of hypoid gear as follows: Apply a uniform thin coat of red lead on both tooth surfaces of 3 or 4 teeth of the hypoid gear. Move the hypoid gear back and forth by turning the transmission main shaft until a definite contact pattern is developed on hypoid gear, and judge whether face contact is correct. If it is incorrect, make the following correction.

- Tooth contact is correct.

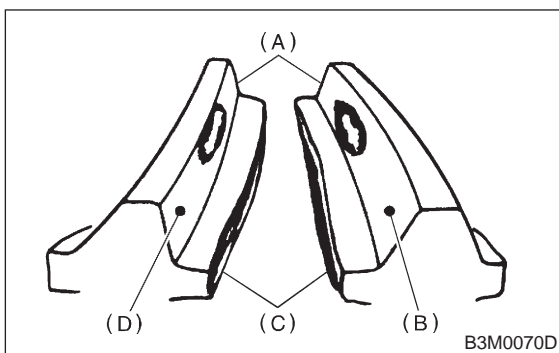

- (A) Toe
- (B) Coast side
- (C) Heel
- (D) Drive side

- Backlash is excessive.

To reduce backlash, loosen holder on the upper side (case right side) and turn in the holder on the lower side (case left side) by the same amount.

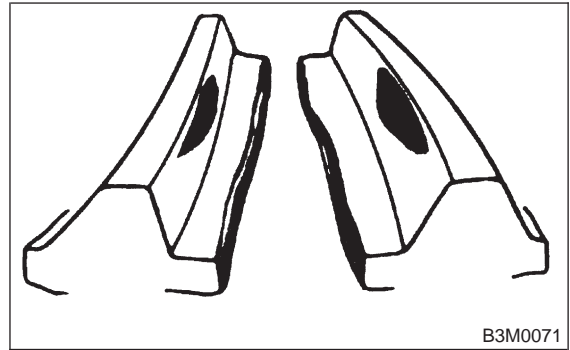

- Backlash is insufficient.

To increase backlash, loosen holder on the lower side (case left side) and turn in the holder on the upper side (case right side) by the same amount.

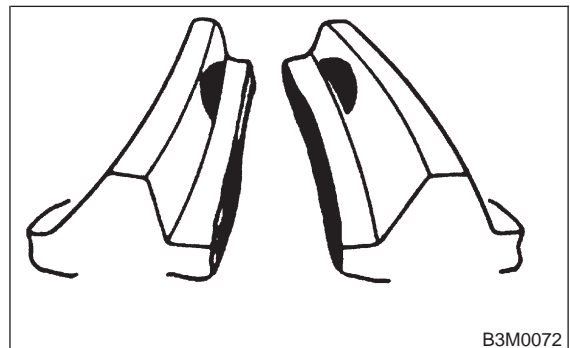

- The drive pinion shim selected before is too thick. Reduce its thickness.

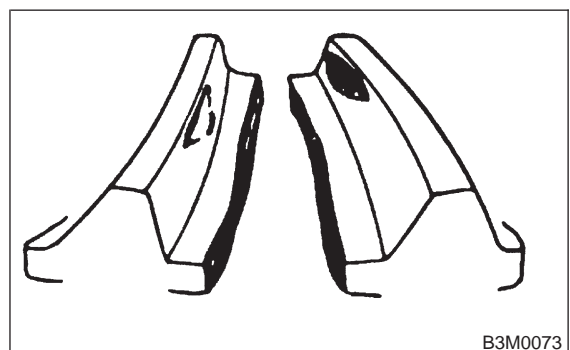

3-1 [W2B2]

2. Transmission Case

SERVICE PROCEDURE

- The drive pinion shim selected before is too thin. Increase its thickness.

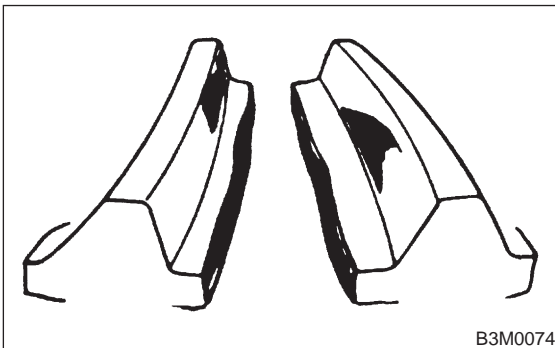

26) After checking the tooth contact of hypoid gears, remove the lock plate. Then loosen retainer until the O-ring groove appears. Fit O-ring into the groove and tighten retainer into the position where retainer has been tightened in. Tighten lock plate.

NOTE:

Carry out this job on both upper and lower retainers.

Tightening torque:

T: 25 ± 3 N·m (2.5 ± 0.3 kg·m, 18.1 ± 2.2 ft·lb)

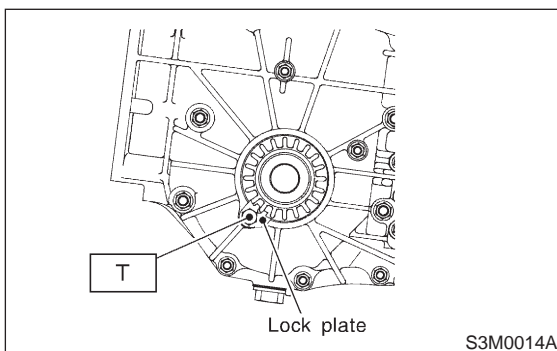

27) Selecting of main shaft rear plate
Using ST, measure the amount (A) of ball bearing protrusion from transmission main case surface and select the proper plate in the following table:
ST 498147000 DEPTH GAUGE

NOTE:

Before measuring, tap the end of main shaft with a plastic hammer lightly in order to make the clearance zero between the main case surface and the moving flange of bearing.

Dimension (A) mm (in)	Part No.	Mark
4.00 — 4.13 (0.1575 — 0.1626)	32294AA041	1
3.87 — 3.99 (0.1524 — 0.1571)	32294AA051	2

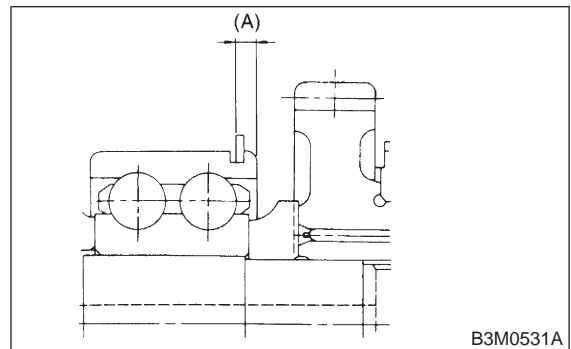

28) Install clutch release lever and bearing. <Ref. to 2-10 [W3C0].>

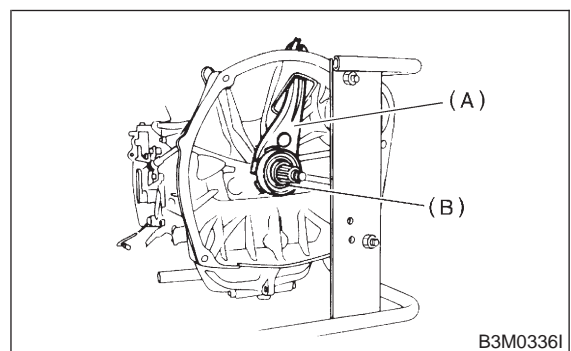

- (A) Clutch release lever
- (B) Release bearing

3. Drive Pinion Assembly

A: DISASSEMBLY

1. DRIVE PINION SHAFT

1) Straighten lock nut at staked portion. Remove the lock nut using ST1, ST2 and ST3.

ST1 899884100 HOLDER
ST2 498427100 STOPPER
ST3 899988608 SOCKET WRENCH

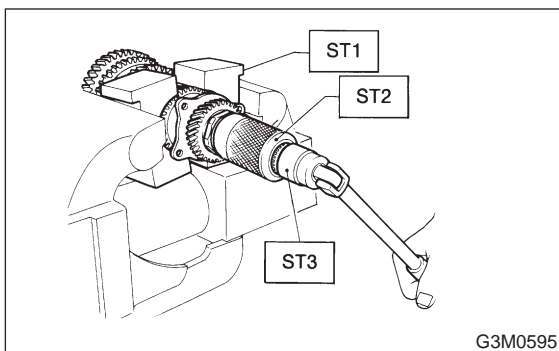

2) Withdraw drive pinion from driven shaft. Remove differential bevel gear sleeve, adjusting washer No. 1, adjusting washer No. 2, thrust bearing, needle bearing, drive pinion collar, needle bearing and thrust bearing.

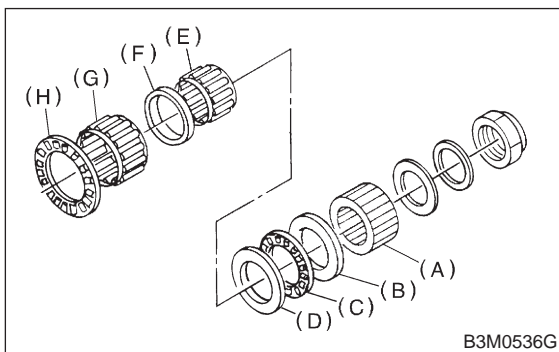

- (A) Differential bevel gear sleeve
- (B) Washer No. 1 (25 × 37.5 × t)
- (C) Thrust bearing (25 × 37.5 × 3)
- (D) Washer No. 2 (25 × 37.5 × 4)
- (E) Needle bearing (25 × 30 × 20)
- (F) Drive pinion collar
- (G) Needle bearing (30 × 37 × 23)
- (H) Thrust bearing (33 × 50 × 3)

3) Remove roller bearing and washer (33 × 50 × 5) using ST and press.

CAUTION:

Do not reuse roller bearing.

ST 498077000 REMOVER

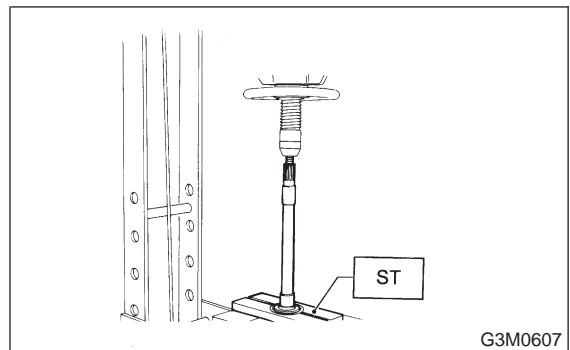

2. DRIVEN GEAR ASSEMBLY

CAUTION:

Attach a cloth to the end of driven shaft (on the frictional side of thrust needle bearing) during disassembly or reassembly to prevent damage.

1) Straighten lock nut at staked portion. Remove the lock nut using ST1 and ST2.

ST1 499987300 SOCKET WRENCH (50)
ST2 899884100 HOLDER

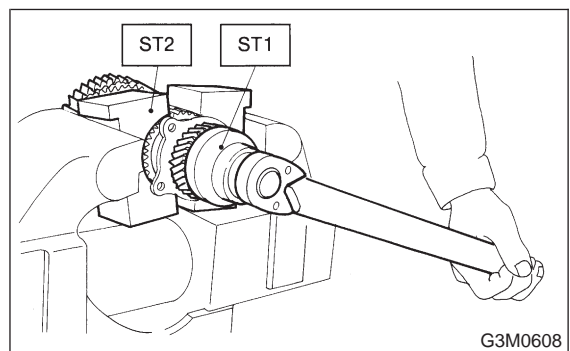

2) Remove 5th driven gear using ST.
ST 499857000 5TH DRIVEN GEAR REMOVER

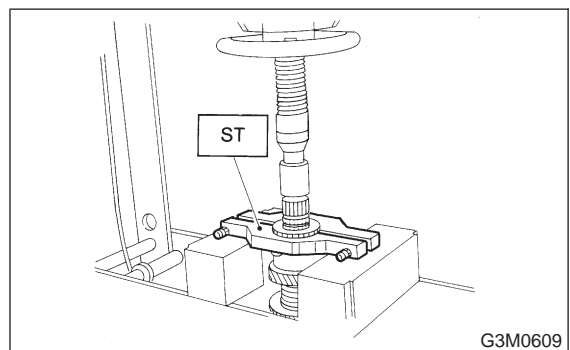

3) Remove woodruff key.

3-1 [W3B1]

3. Drive Pinion Assembly

SERVICE PROCEDURE

4) Remove roller bearing (42 × 74 × 40), 3rd-4th driven gear using ST1 and ST2.

ST1 499757002 SNAP RING PRESS

ST2 899714110 REMOVER

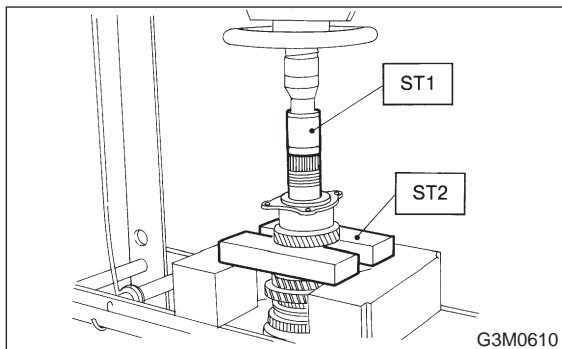

5) Remove the key.

6) Remove 2nd driven gear, inner baulk ring, synchro cone and outer baulk ring.

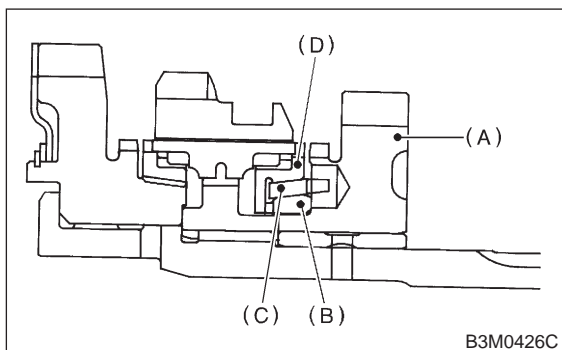

- (A) 2nd driven gear
- (B) Inner baulk ring
- (C) Synchro coner
- (D) Outer baulk ring

7) Remove 1st driven gear, 2nd gear bushing, gear and hub using ST1 and ST2.

NOTE:

Replace gear and hub if necessary. Do not attempt to disassemble if at all possible because they must engage at a specified point. If they have to be disassembled, mark the engaging point beforehand.

ST1 499757002 SNAP RING PRESS

ST2 899714110 REMOVER

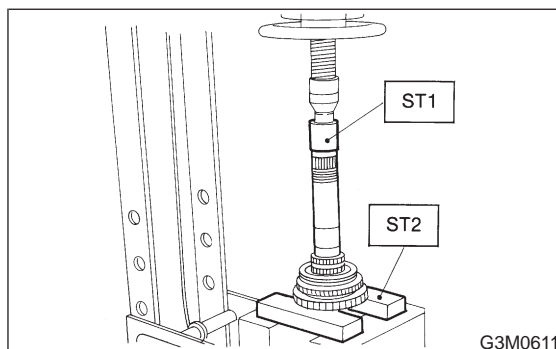

8) Remove sub gears for 1st and 2nd driven gear.

B: ASSEMBLY

1. GEAR AND HUB ASSEMBLY

Assemble gear and hub assembly.

NOTE:

- Use new gear and hub assembly, if gear or hub have been replaced.
- Be sure the insert keys are correctly located in the insert key grooves inside the reverse driven gear.

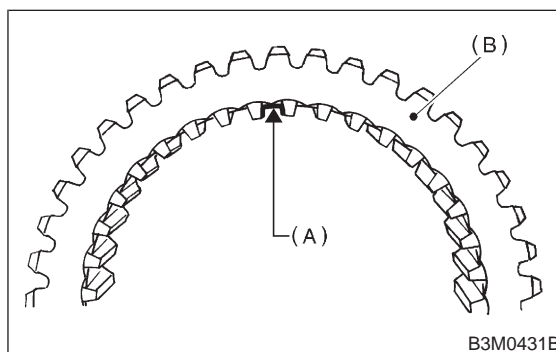

- (A) Key grooves
- (B) Reverse driven gear

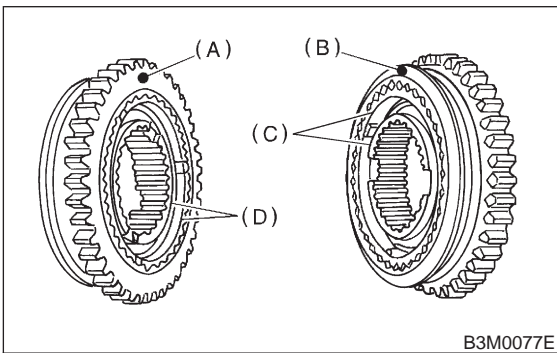

- (A) 1st gear side
- (B) 2nd gear side
- (C) Flush surface
- (D) Stepped surface

2. DRIVEN GEAR ASSEMBLY

Assemble a driven shaft and 1st driven gear that select for adjustment the proper radial clearance.

Driven shaft		1st driven gear
Part No.	Diameter (A) mm (in)	Part No.
32229AA150	49.959 — 49.966 (1.9669 — 1.9672)	32231AA730
32229AA140	49.967 — 49.975 (1.9672 — 1.9675)	32231AA720

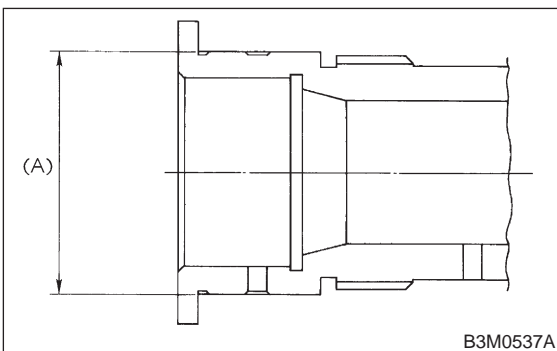

- 1) Install sub gear to 1st driven gear.
- 2) Install 1st driven gear, 1st baulk ring, gear and hub assembly onto driven shaft.

NOTE:

Take care to install gear hub in proper direction.

- 3) Install 2nd driven gear bushing onto driven shaft using ST1, ST2 and press.
ST1 499277200 INSTALLER
ST2 499587000 INSTALLER

CAUTION:

Attach a cloth to the end of driven shaft to prevent damage.

NOTE:

When press fitting, align oil holes of shaft and bush.

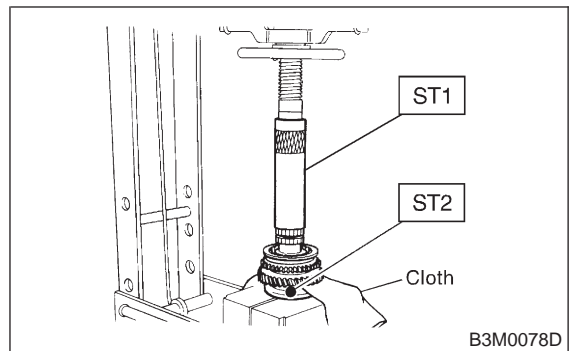

- 4) Install 2nd driven gear, inner baulk ring, synchro cone, outer baulk ring and insert onto driven shaft.

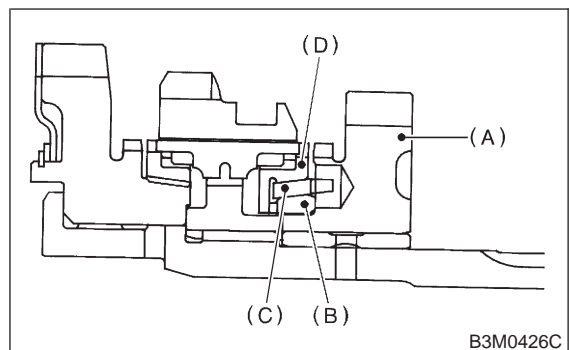

- (A) 2nd driven gear
- (B) Inner baulk ring
- (C) Synchro cone
- (D) Outer baulk ring

3-1 [W3B3]

3. Drive Pinion Assembly

SERVICE PROCEDURE

5) After installing key on driven shaft, install 3rd-4th driven gear using ST and press.

NOTE:

Align groove in baulk ring with insert.

ST 499277200 INSTALLER

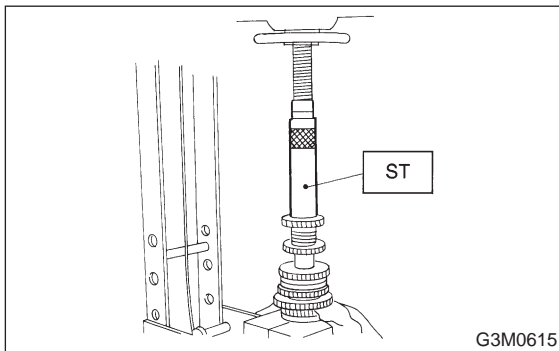

6) Install a set of roller bearings (42 × 74 × 40) onto the driven shaft using ST and press.

ST 499277200 INSTALLER

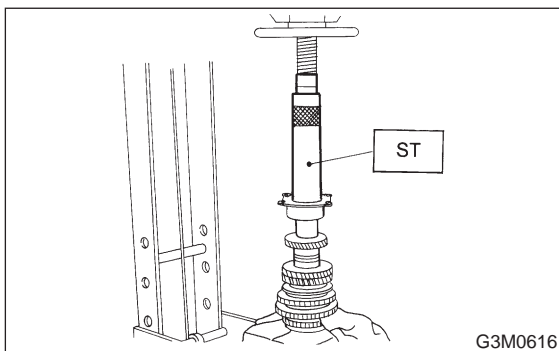

7) Position woodruff key in groove on the rear of driven shaft. Install 5th driven gear onto drive shaft using ST and press.

ST 499277200 INSTALLER

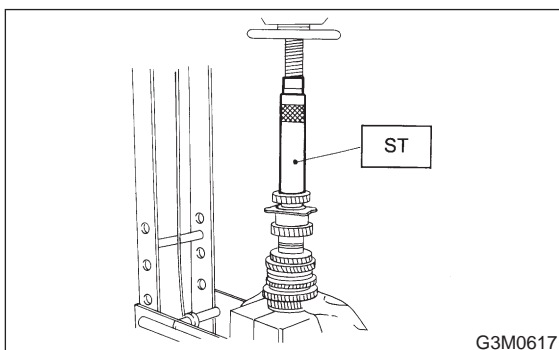

8) Install lock washer (42 × 53 × 2). Install lock nut (42 × 13) and tighten to the specified torque using ST.

ST 499987300 SOCKET WRENCH (50)

Tightening torque:

265±10 N·m (27±1 kg·m, 195±7 ft·lb)

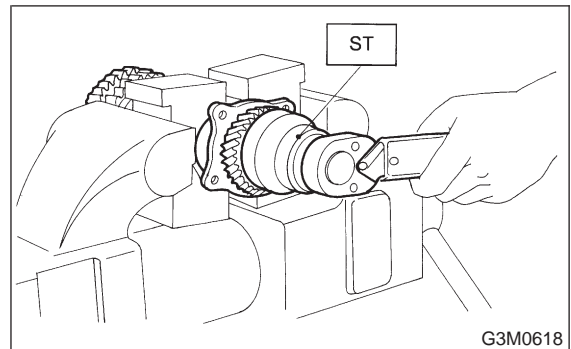

NOTE:

- Stake lock nut at two points.
- Using spring balancer, check that starting torque of roller bearing is 0.1 to 1.5 N·m (0.01 to 0.15 kg·m, 0.07 to 1.1 ft·lb).

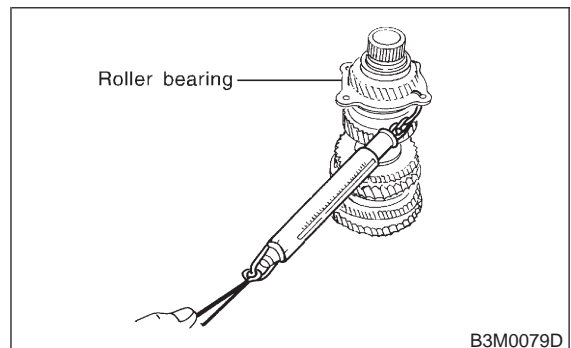

3. DRIVE PINION SHAFT

1) Install roller bearing onto drive pinion. Install washer (33 × 50 × 5) using ST1, ST2 and press.

ST1 499277100 BUSH 1-2 INSTALLER

ST2 499277200 INSTALLER

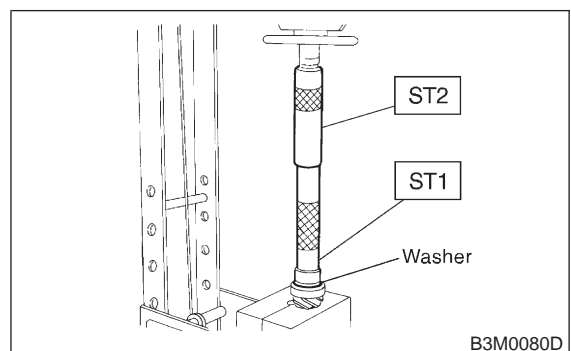

NOTE:

When installing roller bearing, note its directions (front and rear) because knock pin hole in outer race is offset.

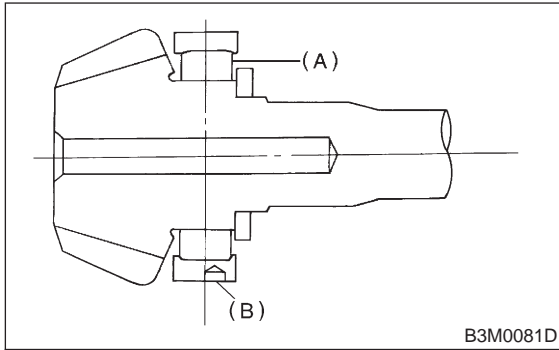

- (A) Roller bearing
- (B) Knock pin hole

2) Install thrust bearing (33 × 50 × 3) and needle bearing (30 × 37 × 23). Install driven shaft assembly.

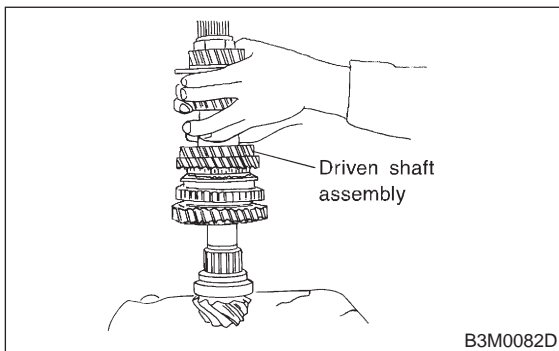

3) Install drive pinion collar, needle bearing, adjusting washer No. 2, thrust bearing, adjusting washer No. 1 and differential bevel gear sleeve in that order.

NOTE:

Be careful because spacer must be installed in proper direction.

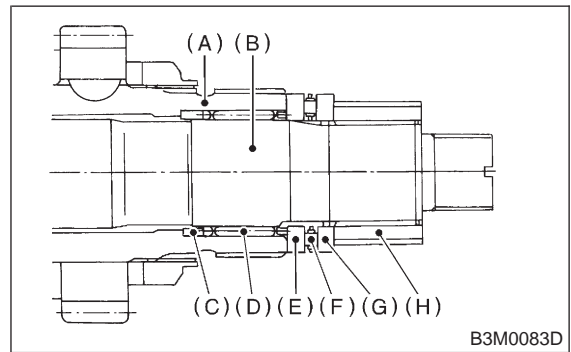

- (A) Driven shaft
- (B) Drive shaft
- (C) Drive pinion collar
- (D) Needle bearing (25 × 30 × 20)
- (E) Washer No. 2 (25 × 36 × 4)
- (F) Thrust bearing (25 × 37.5 × 3)
- (G) Washer No. 1 (25 × 36 × t)
- (H) Differential bevel gear sleeve

C: ADJUSTMENT

1. THRUST BEARING PRELOAD

1) After completing the preceding steps 1) through 3), select adjusting washer No. 2 so that dimension (H) is zero through visual check. Position washer (18.3 × 30 × 4) and lock washer (18 × 30 × 2) and install lock nut (18 × 13.5).

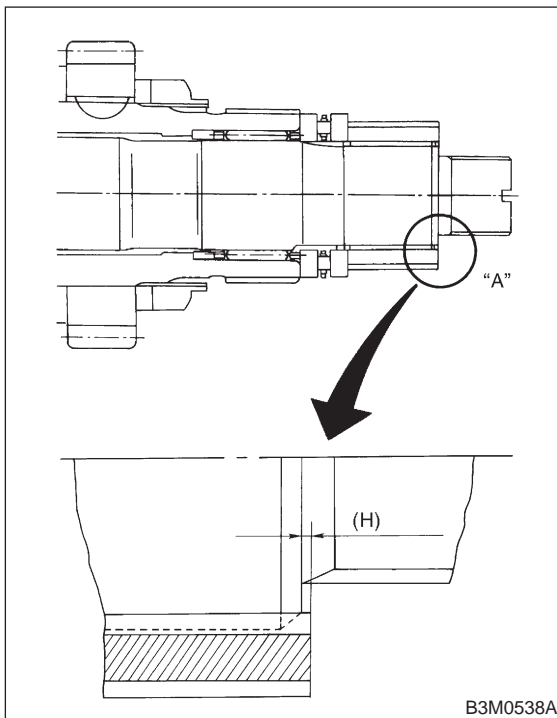

2) Using ST1, ST2 and ST3, tighten lock nut to the specified torque.

- ST1 899884100 HOLDER
- ST2 498427100 STOPPER
- ST3 899988608 SOCKET WRENCH (27)

Tightening torque:
118±8 N·m (12±0.8 kg·m, 86.8±5.8 ft·lb)

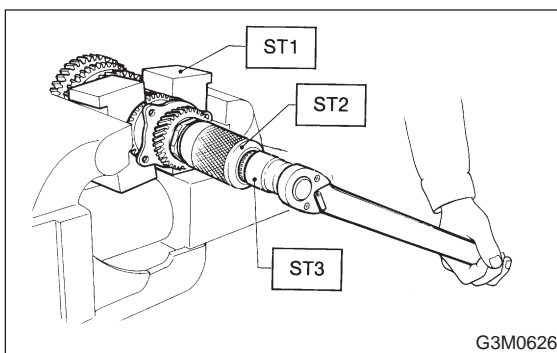

3) After removing ST2, measure starting torque using torque driver.

- ST1 899884100 HOLDER
- ST3 899988608 SOCKET WRENCH (27)

Starting torque:
54±25 N·m (5.5±2.5 kg·m, 40±18 ft·lb)

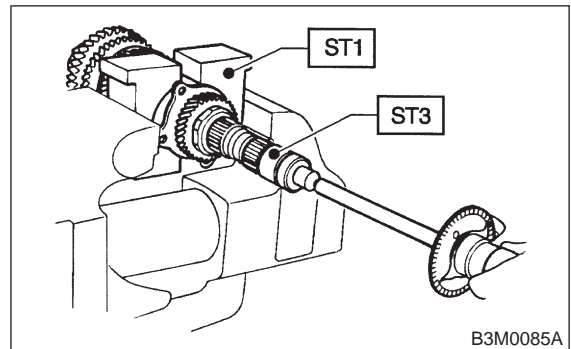

4) If starting torque is not within specified limit, select new adjusting washer No. 1 and recheck starting torque.

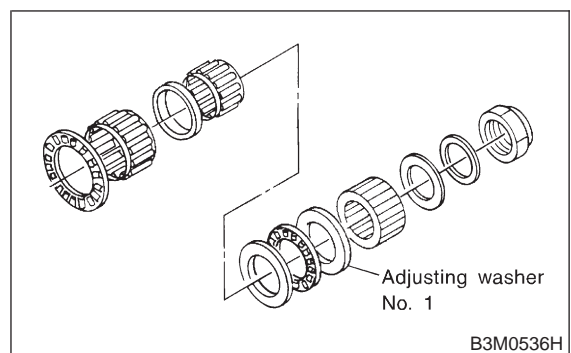

Adjusting washer No. 1	
Part No.	Thickness mm (in)
803025051	3.925 (0.1545)
803025052	3.950 (0.1555)
803025053	3.975 (0.1565)
803025054	4.000 (0.1575)
803025055	4.025 (0.1585)
803025056	4.050 (0.1594)
803025057	4.075 (0.1604)

5) If specified starting torque range cannot be obtained when a No. 1 adjusting washer is used, then select a suitable No. 2 adjusting washer from those listed in the following table. Repeat steps 1) through 4) to adjust starting torque.

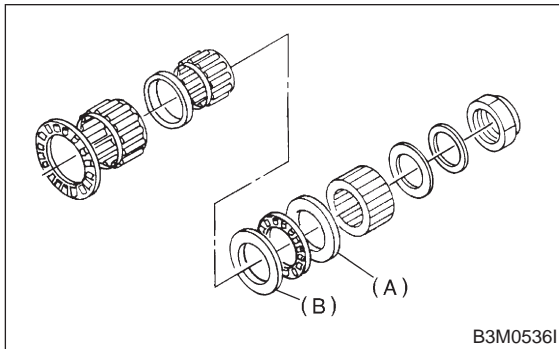

(A) Adjusting washer No. 1
(B) Adjusting washer No. 2

Starting torque	Dimension H	Washer No. 2
Low	Small	Select thicker one.
High	Large	Select thinner one.

Adjusting washer No. 2	
Part No.	Thickness mm (in)
803025059	3.850 (0.1516)
803025054	4.000 (0.1575)
803025058	4.150 (0.1634)

6) Recheck that starting torque is within specified range, then clinch lock nut at four positions.

4. Main Shaft Assembly

A: DISASSEMBLY

1. 2200 cc MODEL

- 1) Put vinyl tape around main shaft splines to protect oil seal from damage. Then pull out oil seal and needle bearing by hand.
- 2) Remove lock nut from transmission main shaft assembly.

NOTE:

Remove caulking before taking off lock nut.

- ST1 498937000 TRANSMISSION HOLDER
ST2 499987003 SOCKET WRENCH (35)

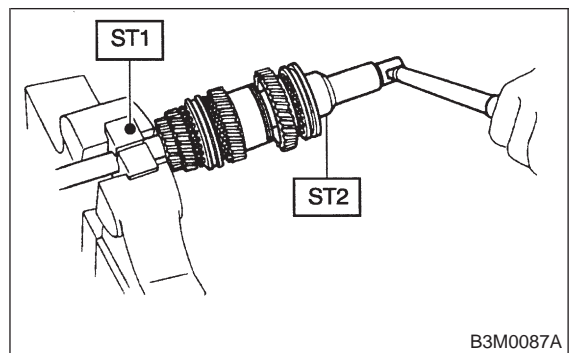

- 3) Remove insert stopper plate, sleeve and hub assembly No. 2, baulk ring, 5th drive gear, and needle bearing.

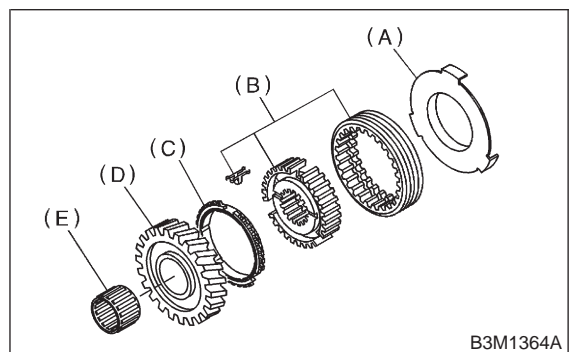

- (A) Insert stopper plate
(B) Sleeve and hub assembly No. 2
(C) Baulk ring
(D) 5th drive gear
(E) Needle bearing (32 × 36 × 25.7)

3-1 [W4A2]

4. Main Shaft Assembly

SERVICE PROCEDURE

4) Using ST1 and ST2, remove the rest of parts.

NOTE:

Replace sleeve and hub with new ones. Do not attempt to disassemble because they must engage at a specified point. If they should be disassembled, marking engagement point on splines beforehand.

ST1 899864100 REMOVER

ST2 899714110 REMOVER

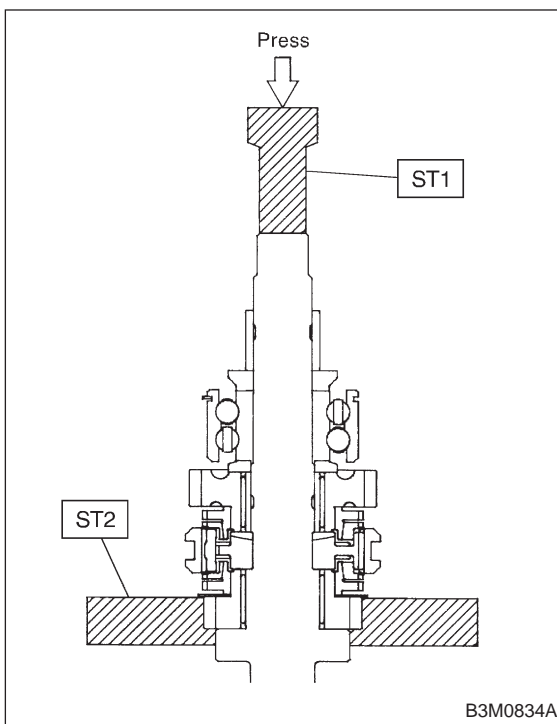

2. 2500 cc MODEL

1) Put vinyl tape around main shaft splines to protect oil seal from damage. Then pull out oil seal and needle bearing by hand.

2) Remove lock nut from transmission main shaft assembly.

NOTE:

Remove caulking before taking off lock nut.

ST1 498937000 TRANSMISSION HOLDER

ST2 499987003 SOCKET WRENCH (35)

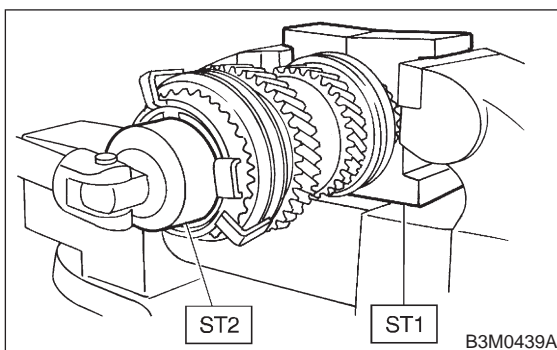

3) Remove 5th-Rev sleeve and hub assembly, baulk ring, 5th drive gear and needle bearing (32 x 36 x 25.7).

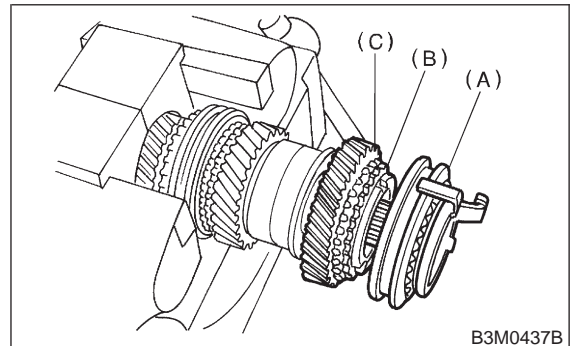

(A) 5th-Rev sleeve and hub ASSY

(B) Baulk ring

(C) 5th drive gear

4) Remove snap ring and synchro cone stopper from 5th-Rev sleeve and hub assembly.

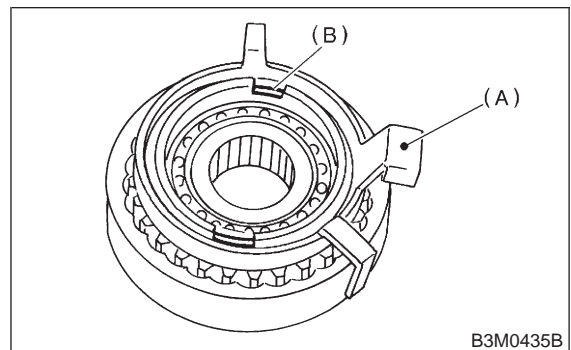

(A) Synchro cone

(B) Snap ring

5) Using ST1 and ST2 and a press, remove ball bearing, synchro cone and baulk ring (Rev).

NOTE:

- Replace sleeve and hub with new ones. Do not attempt to disassemble because they must engage at a specified point. If they should be disassembled, mark engagement point on splines beforehand.

- Do not reuse ball bearing.

ST1 499757002 SNAP RING PRESS

ST2 498077400 SYNCHRO CONE REMOVER

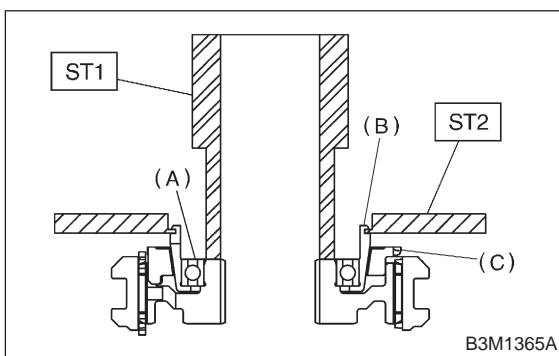

- (A) Ball bearing
- (B) Synchro cone
- (C) Baulk ring

6) Using ST1 and ST2, remove the rest of parts.

NOTE:

Replace sleeve and hub with new ones. Do not attempt to disassemble because they must engage at a specified point. If they should be disassembled, marking engagement point on splines beforehand.

ST1 899864100 REMOVER

ST2 899714110 REMOVER

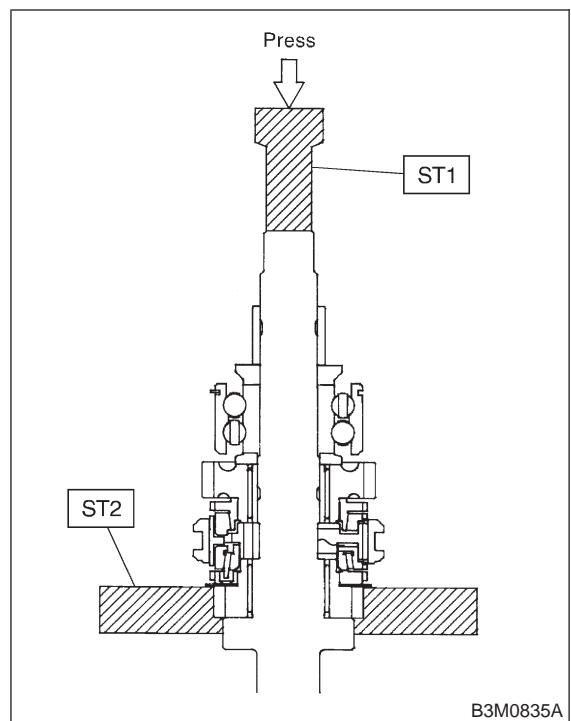

5) If specified starting torque range cannot be obtained when a No. 1 adjusting washer is used, then select a suitable No. 2 adjusting washer from those listed in the following table. Repeat steps 1) through 4) to adjust starting torque.

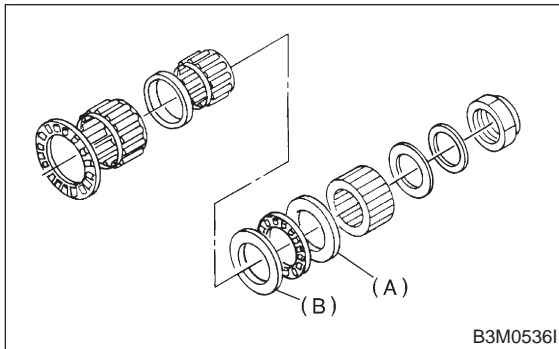

- (A) Adjusting washer No. 1
- (B) Adjusting washer No. 2

Starting torque	Dimension H	Washer No. 2
Low	Small	Select thicker one.
High	Large	Select thinner one.

Adjusting washer No. 2	
Part No.	Thickness mm (in)
803025059	3.850 (0.1516)
803025054	4.000 (0.1575)
803025058	4.150 (0.1634)

6) Recheck that starting torque is within specified range, then clinch lock nut at four positions.

4. Main Shaft Assembly

A: DISASSEMBLY

1. 2200 cc MODEL

- 1) Put vinyl tape around main shaft splines to protect oil seal from damage. Then pull out oil seal and needle bearing by hand.
- 2) Remove lock nut from transmission main shaft assembly.

NOTE:

Remove caulking before taking off lock nut.

- ST1 498937000 TRANSMISSION HOLDER
- ST2 499987003 SOCKET WRENCH (35)

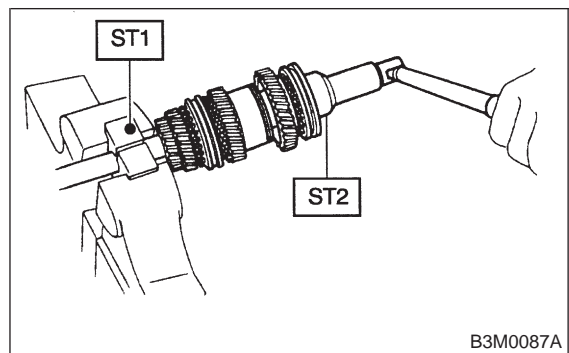

- 3) Remove insert stopper plate, sleeve and hub assembly No. 2, baulk ring, 5th drive gear, and needle bearing.

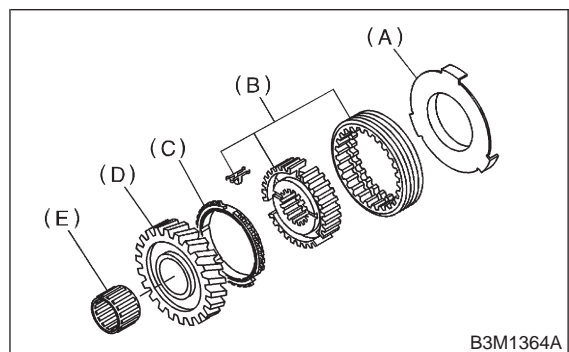

- (A) Insert stopper plate
- (B) Sleeve and hub assembly No. 2
- (C) Baulk ring
- (D) 5th drive gear
- (E) Needle bearing (32 × 36 × 25.7)

3-1 [W4A2]

4. Main Shaft Assembly

SERVICE PROCEDURE

4) Using ST1 and ST2, remove the rest of parts.

NOTE:

Replace sleeve and hub with new ones. Do not attempt to disassemble because they must engage at a specified point. If they should be disassembled, marking engagement point on splines beforehand.

ST1 899864100 REMOVER

ST2 899714110 REMOVER

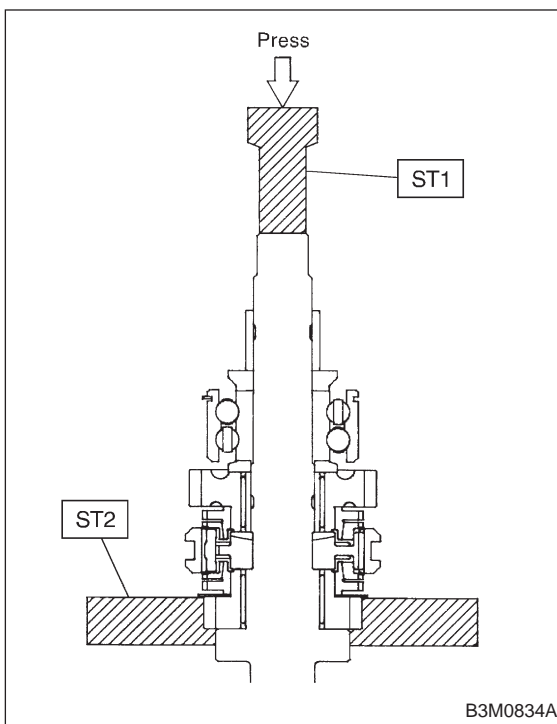

2. 2500 cc MODEL

1) Put vinyl tape around main shaft splines to protect oil seal from damage. Then pull out oil seal and needle bearing by hand.

2) Remove lock nut from transmission main shaft assembly.

NOTE:

Remove caulking before taking off lock nut.

ST1 498937000 TRANSMISSION HOLDER

ST2 499987003 SOCKET WRENCH (35)

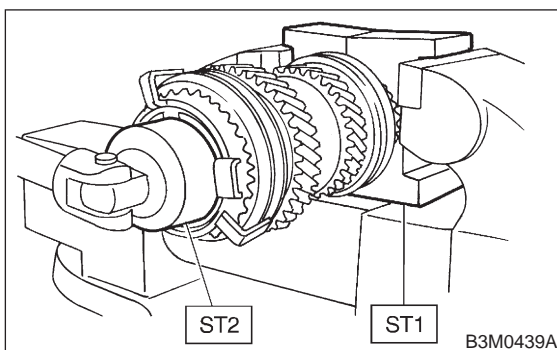

3) Remove 5th-Rev sleeve and hub assembly, baulk ring, 5th drive gear and needle bearing (32 x 36 x 25.7).

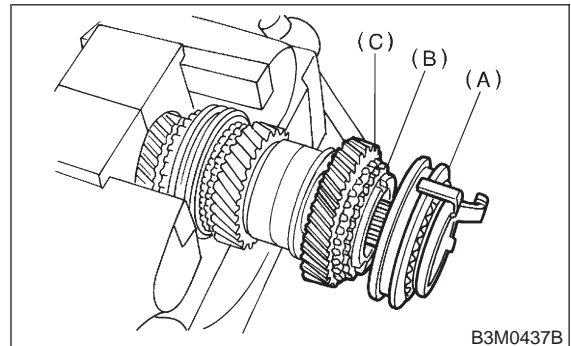

(A) 5th-Rev sleeve and hub ASSY

(B) Baulk ring

(C) 5th drive gear

4) Remove snap ring and synchro cone stopper from 5th-Rev sleeve and hub assembly.

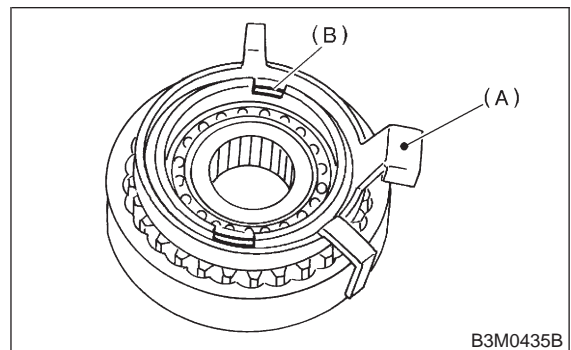

(A) Synchro cone

(B) Snap ring

5) Using ST1 and ST2 and a press, remove ball bearing, synchro cone and baulk ring (Rev).

NOTE:

- Replace sleeve and hub with new ones. Do not attempt to disassemble because they must engage at a specified point. If they should be disassembled, mark engagement point on splines beforehand.

- Do not reuse ball bearing.

ST1 499757002 SNAP RING PRESS

ST2 498077400 SYNCHRO CONE REMOVER

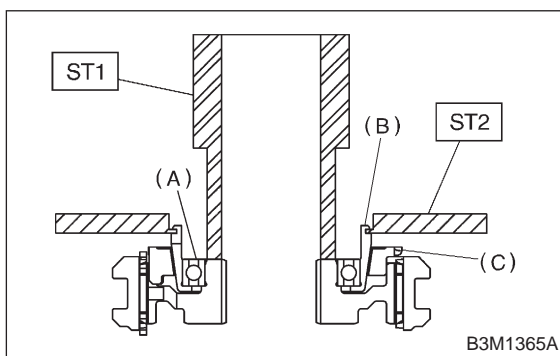

- (A) Ball bearing
- (B) Synchro cone
- (C) Baulk ring

6) Using ST1 and ST2, remove the rest of parts.

NOTE:

Replace sleeve and hub with new ones. Do not attempt to disassemble because they must engage at a specified point. If they should be disassembled, marking engagement point on splines beforehand.

ST1 899864100 REMOVER

ST2 899714110 REMOVER

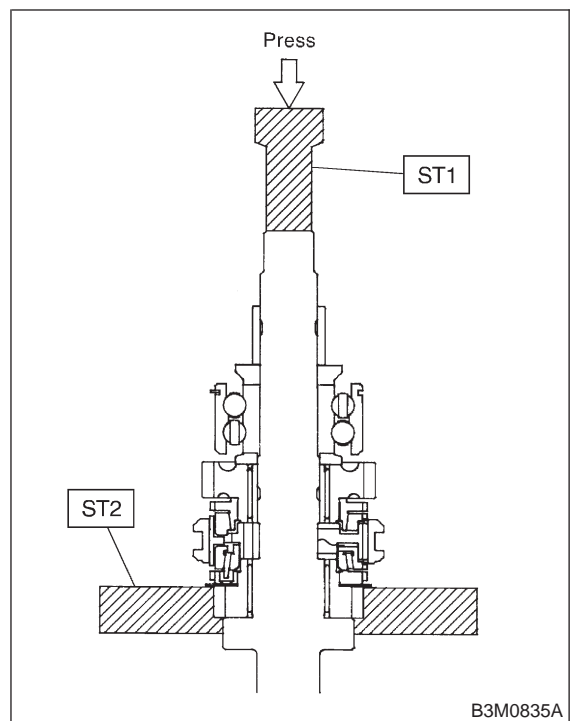

B: ASSEMBLY

1. 2200 cc MODEL

1) Assemble sleeve and hub assembly for 3rd-4th and, 5th synchronizing.

NOTE:

Position open ends of spring 120° apart.

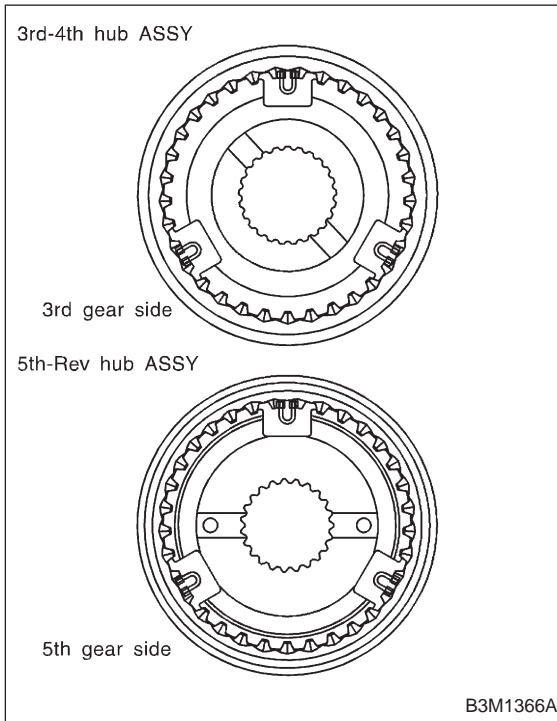

2) Install 3rd drive gear, baulk ring, and sleeve and hub assembly for 3rd-4th needle bearing (32 × 36 × 25.7) on transmission main shaft.

NOTE:

Align groove in baulk ring with shifting insert.

3) Install 4th needle bearing race onto transmission main shaft using ST1, ST2 and a press.

ST1 899714110 REMOVER

ST2 499877000 RACE 4-5 INSTALLER

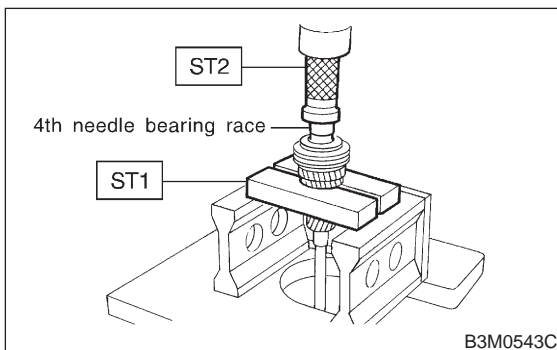

4) Install baulk ring, needle bearing (32 × 30 × 25.7), 4th drive gear and 4th gear thrust washer to transmission main shaft.

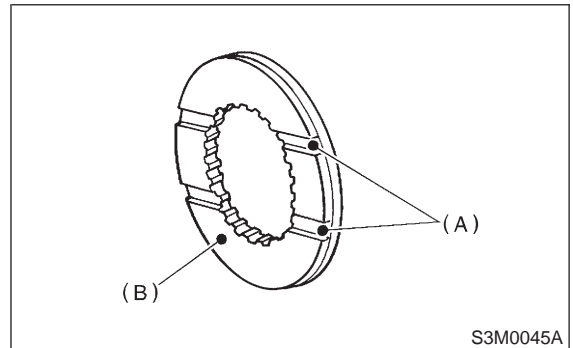

(A) Groove

(B) 4th gear side

5) Drive ball bearing onto the rear section of transmission main shaft using ST1, ST2 and a press.

ST1 899714110 REMOVER

ST2 499877000 RACE 4-5 INSTALLER

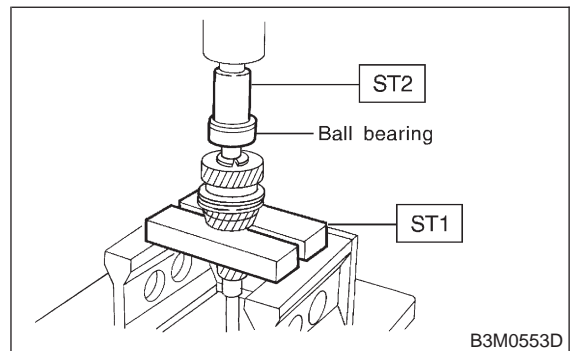

6) Using ST1 and ST2, install the 5th gear thrust washer and 5th needle bearing race onto the rear section of transmission main shaft.

NOTE:

Face thrust washer in the correct direction.

ST1 899714110 REMOVER

ST2 499877000 RACE 4-5 INSTALLER

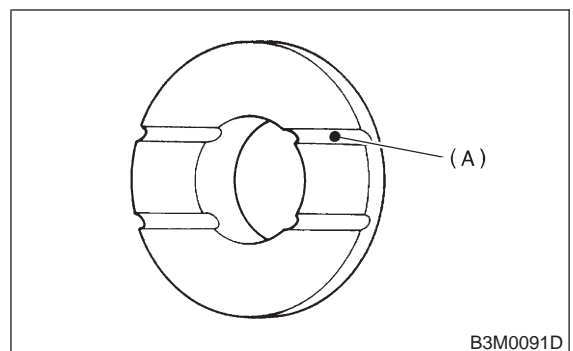

(A) Face this surface to 5th gear side.

7) Install the following parts to the rear section of transmission main shaft.

NOTE:

- Align groove in baulk ring with shifting insert.
- Be sure to fit pawl of insert stopper plate into 4 mm (0.16 in) dia. hole in the boss section of synchronizer hub.

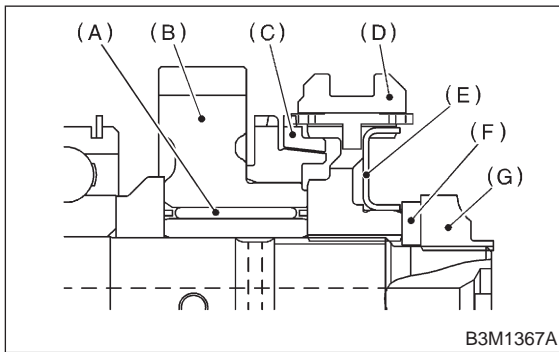

- (A) Needle bearing (32 × 36 × 25.7)
- (B) 5th drive gear
- (C) Baulk ring
- (D) Sleeve and hub assembly
- (E) Insert stopper plate
- (F) Lock washer (22 × 38 × 2)
- (G) Lock nut

8) Tighten lock nuts (22 × 13) to the specified torque using ST1 and ST2.

NOTE:

Secure lock nuts in two places after tightening.

- ST1 499987003 SOCKET WRENCH (35)
- ST2 498937000 TRANSMISSION HOLDER

Tightening torque:

118±6 N·m (12.0±0.6 kg·m, 86.8±4.3 ft·lb)

2. 2500 cc MODEL

1) Assemble sleeve and hub assembly for 3rd-4th and, 5th synchronizing.

NOTE:

Position open ends of spring 120° apart.

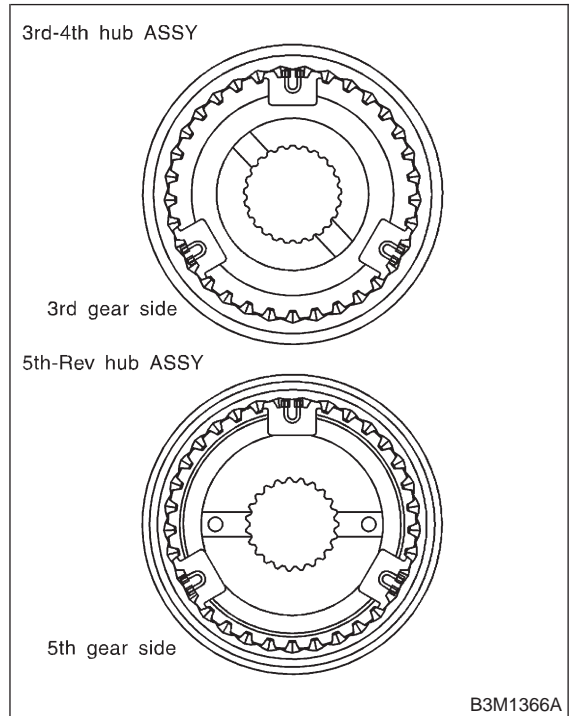

2) Install 3rd drive gear, outer baulk ring, synchro cone, inner baulk ring, sleeve and hub assembly for 3rd needle bearing on transmission main shaft.

NOTE:

Align groove in baulk ring with insert key.

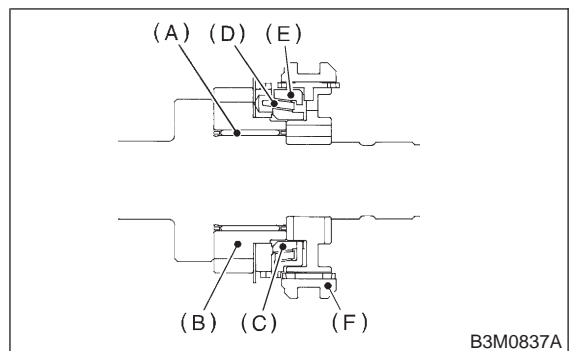

- (A) 3rd needle bearing (32 × 36 × 25.7)
- (B) 3rd drive gear
- (C) Inner baulk ring
- (D) Synchro cone
- (E) Outer baulk ring
- (F) Sleeve and hub ASSY

3-1 [W4B2]

4. Main Shaft Assembly

SERVICE PROCEDURE

3) Install 4th needle bearing race onto transmission main shaft using ST1, ST2 and a press.

ST1 899714110 REMOVER

ST2 499877000 RACE 4-5 INSTALLER

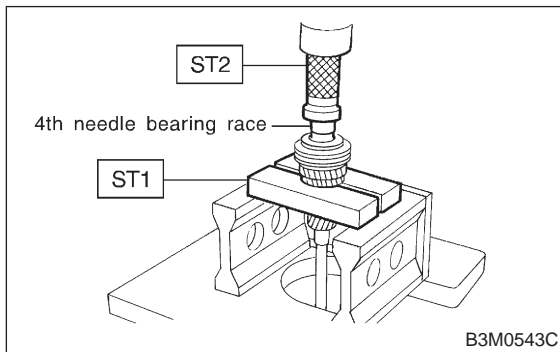

4) Install baulk ring, needle bearing (32 × 30 × 25.7), 4th drive gear and 4th gear thrust washer to transmission main shaft.

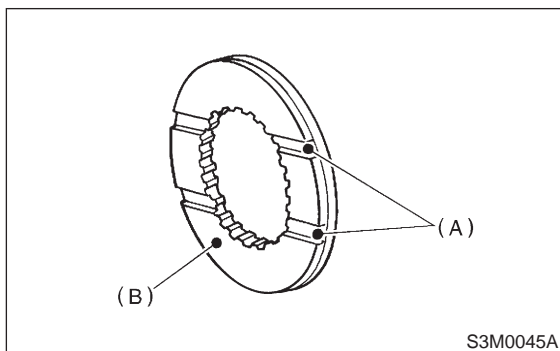

(A) Groove

(B) 4th gear side

5) Drive ball bearing onto the rear section of transmission main shaft using ST1, ST2 and a press.

ST1 899714110 REMOVER

ST2 499877000 RACE 4-5 INSTALLER

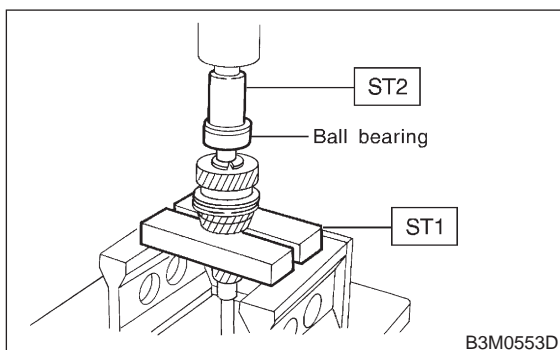

6) Using ST1 and ST2, install the 5th gear thrust washer and 5th needle bearing race onto the rear section of transmission main shaft.

NOTE:

Face thrust washer in the correct direction.

ST1 899714110 REMOVER

ST2 499877000 RACE 4-5 INSTALLER

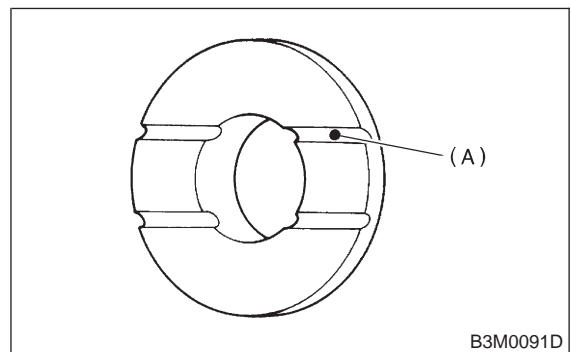

(A) Face this surface to 5th gear side.

7) Install bearing onto synchro cone.

8) Install baulk ring and synchro cone onto 5th-Rev sleeve and hub assembly using ST and a press.

NOTE:

- Using new ball bearing.

- After press fitting, make sure synchro cone rotates freely.

ST 499757002 SNAP RING PRESS

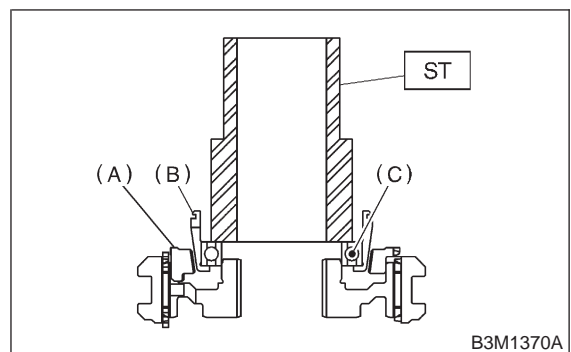

(A) Baulk ring

(B) Synchro cone

(C) Ball bearing

9) Install synchro cone stopper and snap ring to 5th-Rev sleeve and hub assembly.

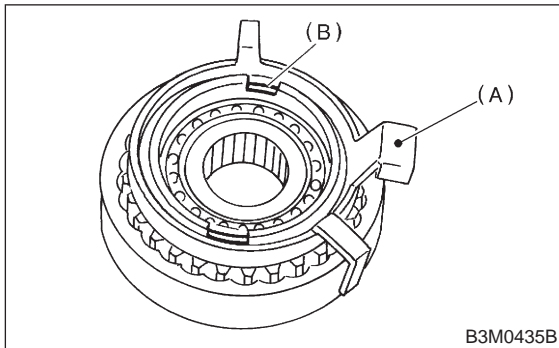

- (A) Synchro cone stopper
- (B) Snap ring

10) Install the rest parts to the rear section of transmission main shaft.

NOTE:

After groove in baulk ring with shifting insert.

- ST 499987003 SOCKET WRENCH
- ST 498937000 TRANSMISSION HOLDER

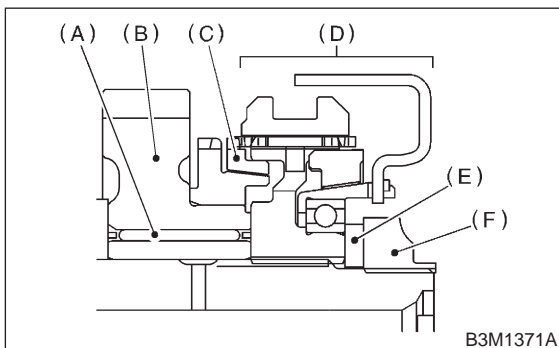

- (A) Needle bearing (32 x 36 x 25.7)
- (B) 5th drive gear
- (C) Baulk ring
- (D) 5th-Rev sleeve and hub ASSY
- (E) Lock washer (22 x 38 x 2)
- (F) Lock nuts (22 x 13)

11) Tighten lock nuts to the specified torque using ST1 and ST2.

NOTE:

Secure lock nuts in two places after tightening.

- ST1 499987000 SOCKET WRENCH
- ST2 498937000 TRANSMISSION HOLDER

Tightening torque:

118±6 N·m (12.0±0.6 kg·m, 86.8±4.3 ft·lb)

5. Transfer Case and Extension

A: REMOVAL

1) Remove back-up light switch and neutral switch.

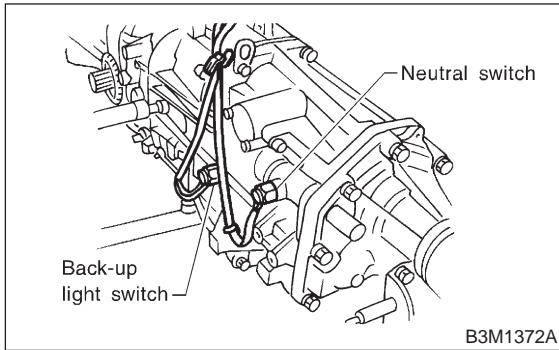

2) Remove transfer case with extension assembly.

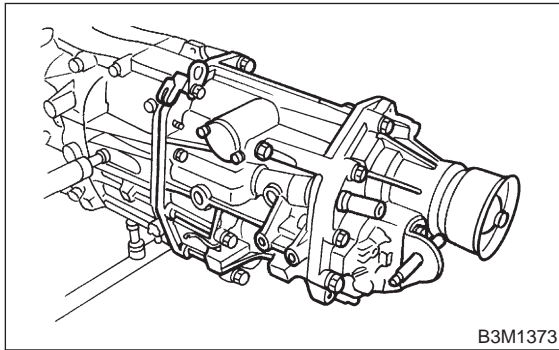

3) Remove shifter arm.

B: DISASSEMBLY

1. SEPARATION OF TRANSFER CASE AND EXTENSION ASSEMBLY

1) Separate transfer case and extension assembly.

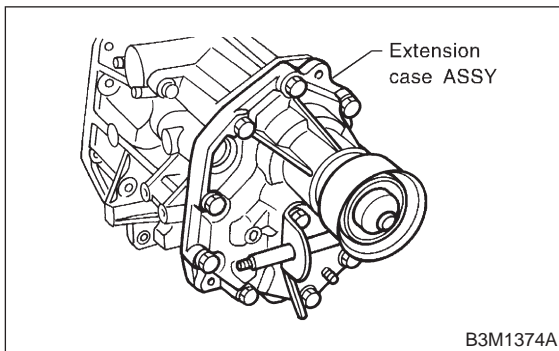

2) Remove transfer driven gear and center differential as a set.

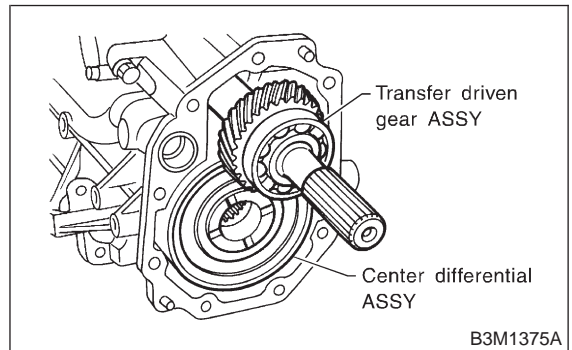

3) Remove thrust washer.

2. TRANSFER CASE

1) Remove plug, spring and reverse check ball.

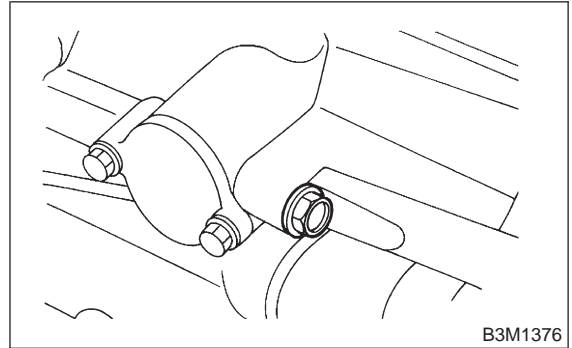

2) Remove reverse check assembly.

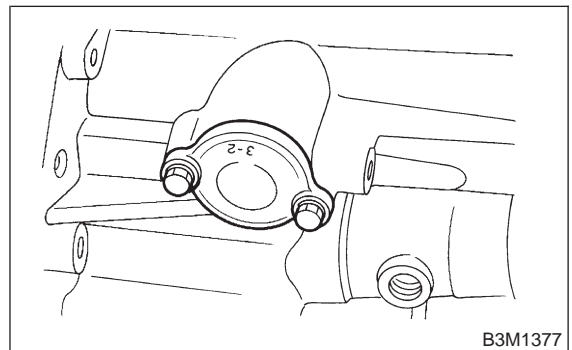

3) Remove oil guide.

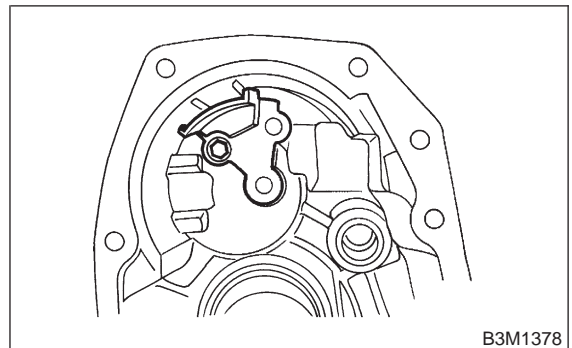

3. EXTENSION

- 1) Remove transfer drive gear assembly.

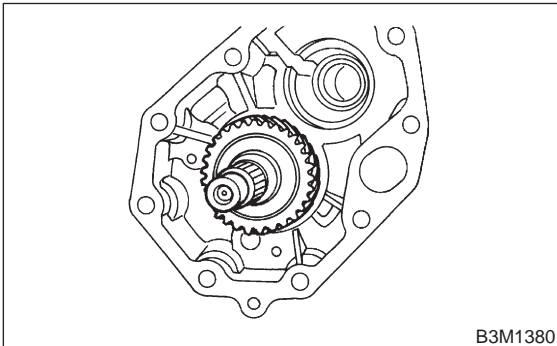

- 2) Remove shift bracket.

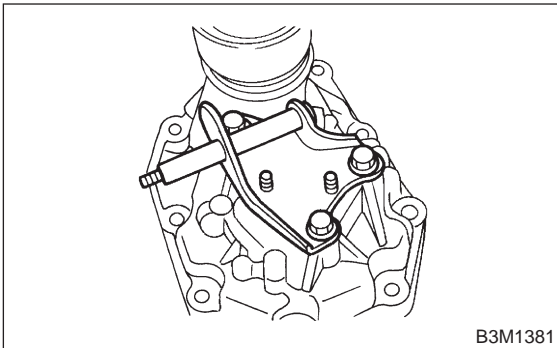

- 3) Using ST, remove ball bearing from transfer drive gear.

ST 498077100 REMOVER

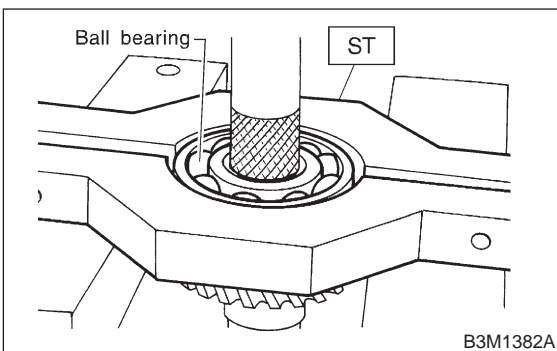

- 4) Remove oil seal from extension case.

4. REVERSE CHECK SLEEVE

- 1) Using a standard screwdriver, remove snap ring.

NOTE:

Replace snap ring with a new one if deformed or weakened.

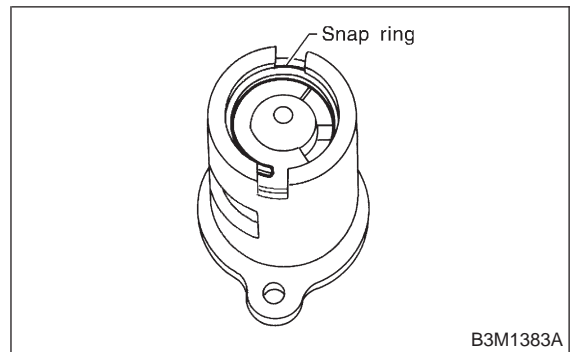

- 2) Remove reverse check plate, reverse check spring, reverse check cam, return spring (5th-Rev), reverse accent shaft, return spring cap and return spring (1st-2nd).

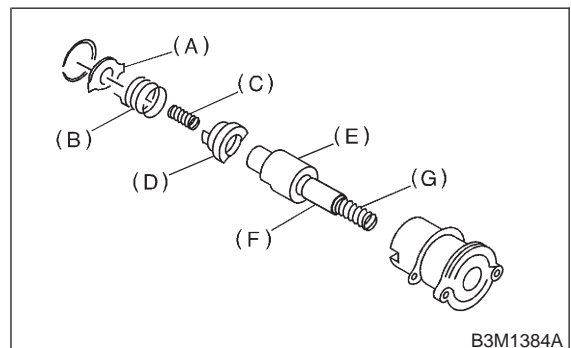

- (A) Reverse check plate
- (B) Reverse check spring
- (C) Return spring (5th-Rev)
- (D) Reverse check cam
- (E) Reverse accent shaft
- (F) Return spring cap
- (G) Return spring (1st-2nd)

5. Transfer Case and Extension

3) Remove O-ring.

NOTE:

- Reverse check sleeve assembly uses an O-ring which should not be scratched.
- Be careful not to break adjustment shim placed between reverse check sleeve assembly and case.

5. TRANSFER DRIVEN GEAR

1) Using ST, remove ball bearing from transfer driven gear

ST 498077000 REMOVER

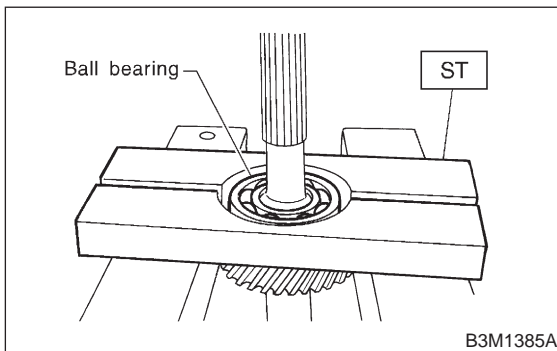

2) Using ST, remove ball bearing from transfer driven gear

ST 899864100 REMOVER

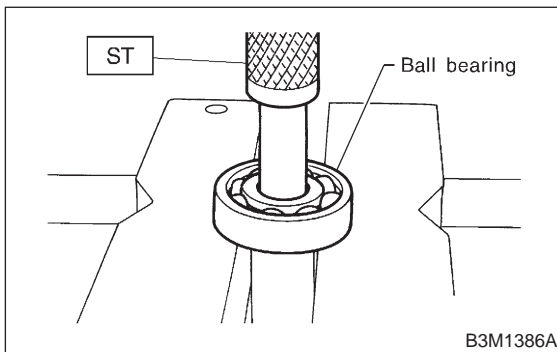

C: ASSEMBLY

1. EXTENSION

1) Install ball bearing to transfer drive gear.

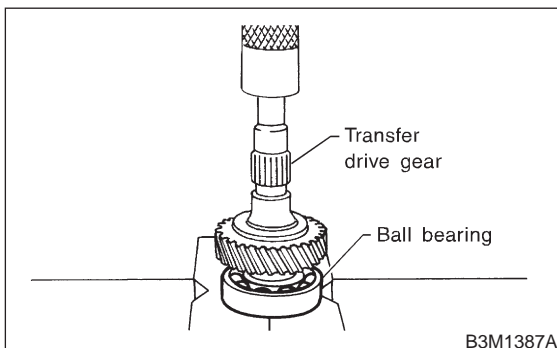

2) Using ST, install oil seal to extension case.

CAUTION:

Use new oil seal.

ST 498057300 INSTALLER

3) Install shift bracket to extension case.

Tightening torque:

25±2 N·m (2.5±0.2 kg·m, 18.1±1.4 ft·lb)

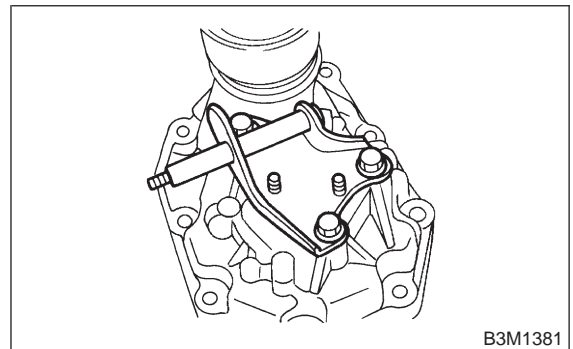

4) Install transfer drive gear to extension case.

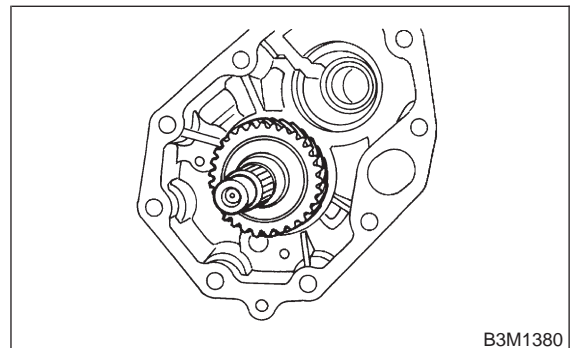

2. REVERSE CHECK SLEEVE

1) Install return spring (1st-2nd), return spring cap, reverse accent shaft, check cam, return spring and check spring onto reverse check sleeve.

NOTE:

Be sure the bent section of reverse check spring is positioned in the groove in check cam.

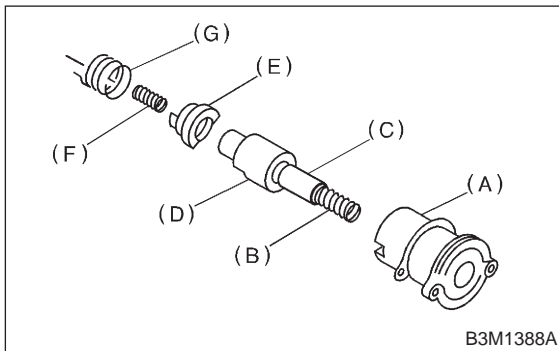

- (A) Reverse check sleeve
- (B) Return spring (1st-2nd)
- (C) Return spring cap
- (D) Reverse accent shaft
- (E) Return spring (5th-Rev)
- (F) Reverse check cam
- (G) Reverse check spring

- 2) Hook the bent section of reverse check spring over reverse check plate.
- 3) Rotate cam so that the protrusion of reverse check cam is at the opening in plate.
- 4) With cam held in that position, install plate onto reverse check sleeve and hold with snap ring.
- 5) Position O-ring in groove in sleeve.

CAUTION:

- Make sure the cutout section of reverse accent shaft is aligned with the opening in reverse check sleeve.
- Spin cam by hand for smooth rotation.
- Move cam and shaft all the way toward plate and release.

If cam does not return properly, replace reverse check spring; if shaft does not, check for scratches on the inner surface of sleeve. If sleeve is in good order, replace spring.

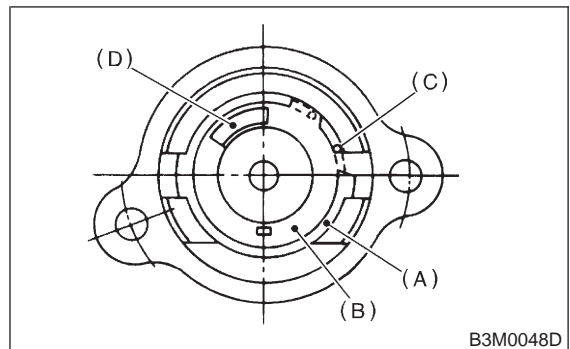

- (A) Snap ring
- (B) Reverse check plate
- (C) Check spring
- (D) Check cam

- Select a suitable reverse accent shaft and reverse check plate. <Ref. to 3-1 [W5E0].>

3. TRANSFER CASE

1) Install oil guide to transfer case.

Tightening torque:

6.4±0.5 N-m (0.65±0.05 kg-m, 4.7±0.4 ft-lb)

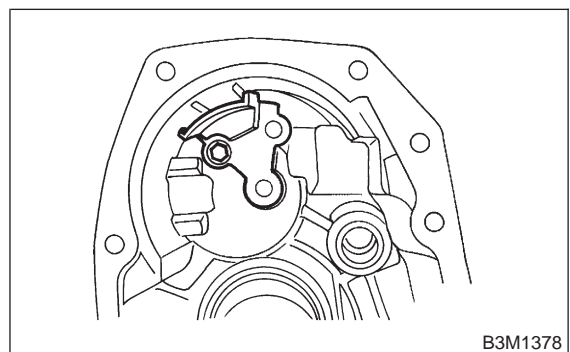

3-1 [W5C4]

SERVICE PROCEDURE

5. Transfer Case and Extension

- 2) Install reverse check sleeve assembly to transfer case.

Tightening torque:

$6.4 \pm 0.5 \text{ N}\cdot\text{m}$ ($0.65 \pm 0.05 \text{ kg}\cdot\text{m}$, $4.7 \pm 0.4 \text{ ft}\cdot\text{lb}$)

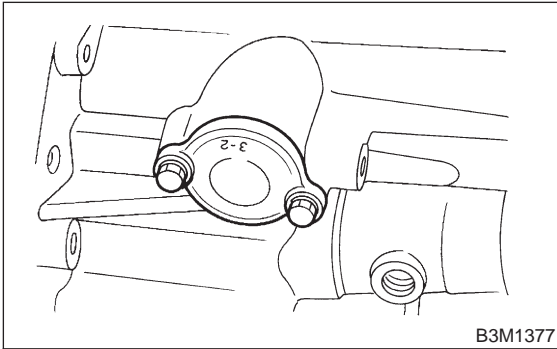

- 3) Install ball, reverse accent spring, washer and plug to transfer case.

Tightening torque:

$10 \pm 1 \text{ N}\cdot\text{m}$ ($1.0 \pm 0.1 \text{ kg}\cdot\text{m}$, $7.2 \pm 0.7 \text{ ft}\cdot\text{lb}$)

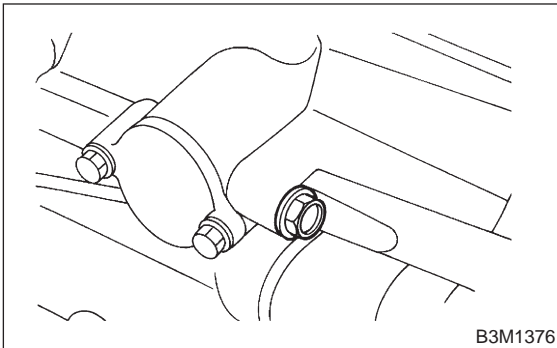

4. TRANSFER DRIVEN GEAR

- 1) Install ball bearing to transfer driven gear.

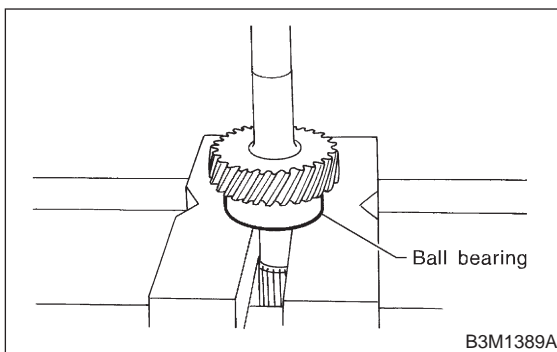

- 2) Install ball bearing to transfer driven gear.

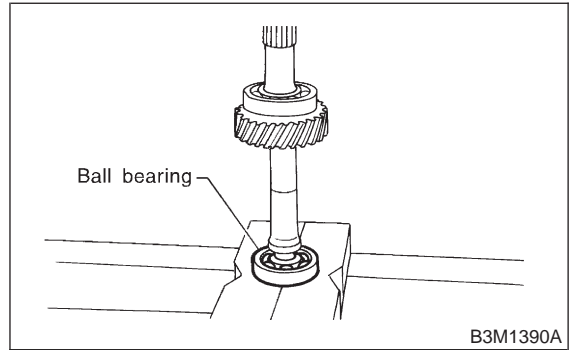

5. COMBINATION OF TRANSFER CASE AND EXTENSION ASSEMBLY

- 1) Install center differential and transfer driven gear into transfer case.

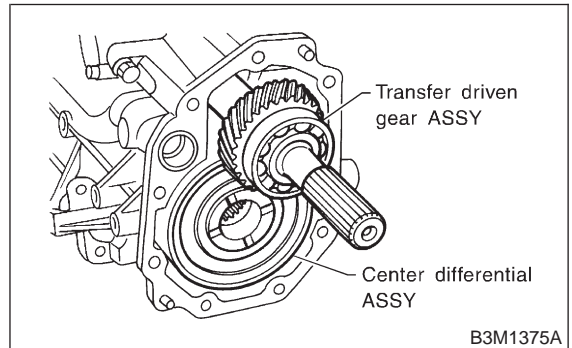

- 2) Measure height "W" between transfer case and ball bearing on the transfer driven gear.

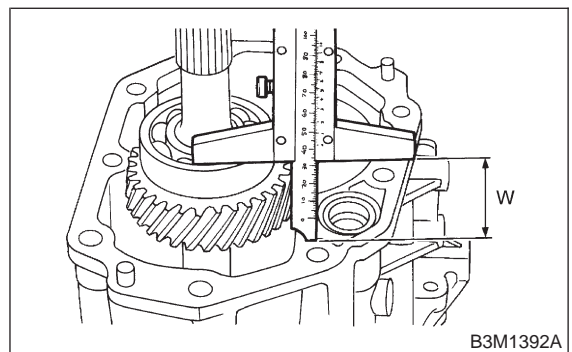

- 3) Measure depth "X".

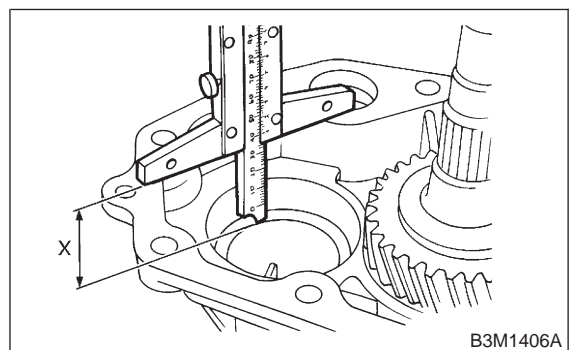

4) Calculate space "Y" using the following equation: $Y = X - W + 0.24 \text{ mm (0.0094 in)}$ [Thickness of gasket]

5) Select suitable washer in the following table:

Standard clearance between thrust washer and ball bearing:

0.05 — 0.30 mm (0.0020 — 0.0118 in)

Space "Y" mm (in)	Thrust washer (52 × 61 × t)	
	Part No.	Thickness mm (in)
0.55 — 0.79 (0.0217 — 0.0311)	803052021	0.50 (0.0197)
0.80 — 1.04 (0.0315 — 0.0409)	803052022	0.75 (0.0295)
1.05 — 1.30 (0.0413 — 0.0512)	803052023	1.00 (0.0394)

6) Fit thrust washers on transfer drive shaft.

7) Measure depth "S" between transfer case and center differential.

ST 398643600 GAUGE

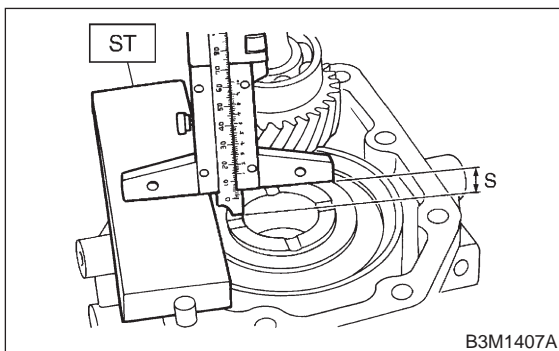

8) Measure depth "T" between extension case and transfer drive gear.

ST 398643600 GAUGE

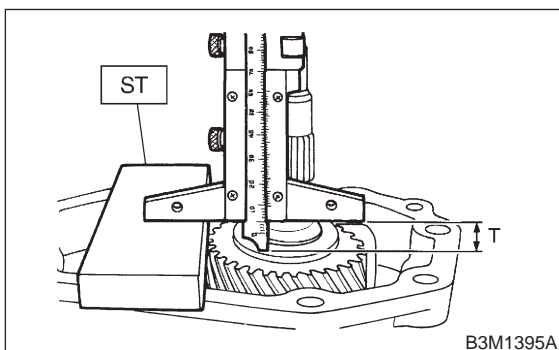

9) Calculate space "U" using the following equation: $U = S + T - 0.24 \text{ mm (0.0094 in)}$ [Thickness of gasket]

10) Select suitable washer in the following table:

Standard clearance:

0.15 — 0.35 mm (0.0059 — 0.0138 in)

Thrust washer	
Part No.	Thickness mm (in)
803036050	0.9 (0.035)
803036054	1.0 (0.039)
803036051	1.1 (0.043)
803036055	1.2 (0.047)
803036052	1.3 (0.051)
803036056	1.4 (0.055)
803036053	1.5 (0.059)
803036057	1.6 (0.063)
803036058	1.7 (0.067)

11) Fit thrust washer on center differential.

12) Install extension assembly into transfer case.

Tightening torque:

37±3 N·m (3.8±0.3 kg·m, 27.5±2.2 ft·lb)

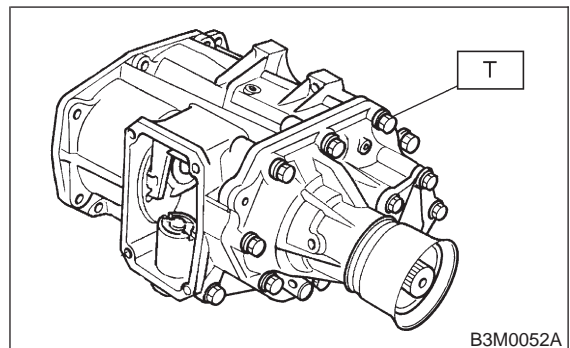

D: INSTALLATION

1) Install shifter arm to transfer case.

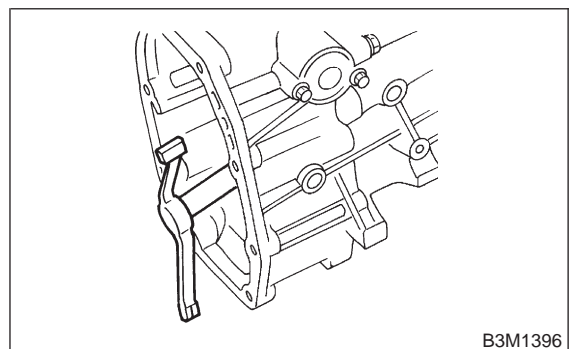

2) Hang the shifter arm on the 3rd-4th fork rod.

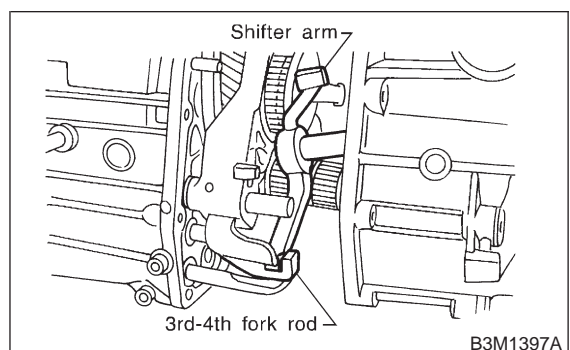

3) Install transfer case with extension assembly to transmission case.

Tightening torque:

24.5±2.0 N·m (2.50±0.20 kg·m, 18.1±1.4 ft·lb)

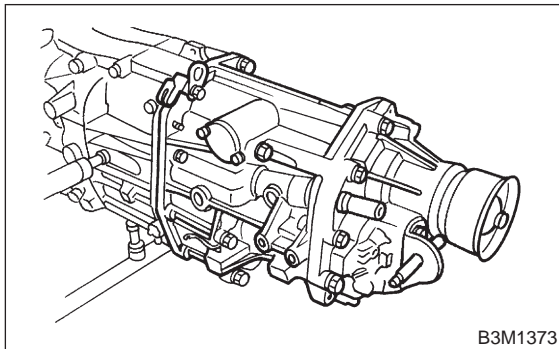

E: ADJUSTMENT

1. NEUTRAL POSITION ADJUSTMENT

- 1) Shift gear into 3rd gear position.
- 2) Shifter arm turns lightly toward the 1st/2nd gear side but heavily toward the reverse gear side because of the function of the return spring, until arm contacts the stopper.
- 3) Make adjustment so that the heavy stroke (reverse side) is a little more than the light stroke (1st/2nd side).
- 4) To adjust, remove bolts holding reverse check sleeve assembly to the case, move sleeve assembly outward, and place adjustment shim (0 to 1 ea.) between sleeve assembly and case to adjust the clearance.

CAUTION:

Be careful not to break O-ring when placing shim(s).

NOTE:

- When shim is removed, the neutral position will move closer to reverse; when shim is added, the neutral position will move closer to 1st gear.
- If shims alone cannot adjust the clearance, replace reverse accent shaft and re-adjust.

Adjustment shim	
Part No.	Thickness mm (in)
32190AA000	0.15 (0.0059)
32190AA010	0.30 (0.0118)

Reverse accent shaft		
Part No.	Mark	Remarks
32188AA090	X	Neutral position is closer to 1st gear.
32188AA100	Y	Standard
32188AA110	Z	Neutral position is closer to reverse gear.

2. REVERSE CHECK PLATE ADJUSTMENT

- 1) Shift shifter arm to “5th” and then to reverse to see if reverse check mechanism operates properly.
- 2) Also check to see if arm returns to neutral when released from the reverse position. If arm does not return properly, replace reverse check plate.

Reverse check plate			
Part No.	(A): No.	Angle θ	Remarks
32189AA000	0	28°	Arm stops closer to 5th gear.
32189AA010	1	31°	Arm stops closer to 5th gear.
32189AA020	2	34°	Arm stops in the center.
32189AA030	3	37°	Arm stops closer to reverse gear.
32189AA040	4	40°	Arm stops closer to reverse gear.

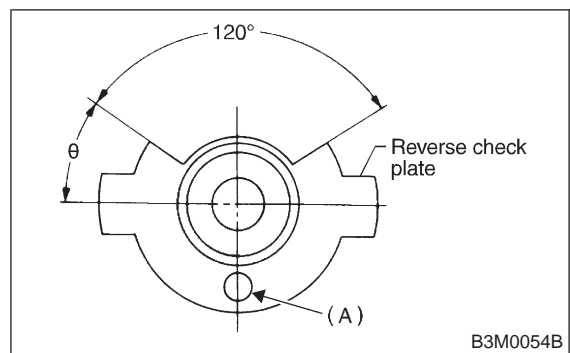

- 3) Install neutral position switch and back-up light switch to transfer case.

Tightening torque:

24.5±2.0 N·m (2.50± 0.20 kg·m, 18.1±1.4 ft·lb)

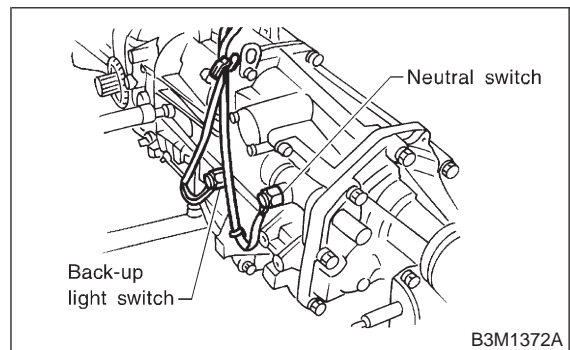

6. Front Differential

A: DISASSEMBLY

1) Remove right and left snap rings from differential, and then remove two axle drive shafts.

NOTE:

During reassembly, reinstall each axle drive shaft in the same place from which it was removed.

2) Loosen twelve bolts and remove hypoid drive gear.

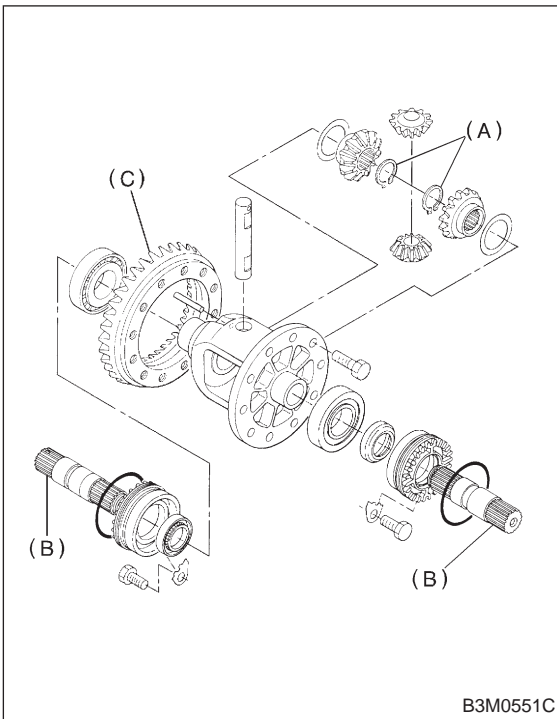

- (A) Snap ring
- (B) Axle drive shaft
- (C) Hypoid drive gear

3) Drive out straight pin from differential assembly toward hypoid driven gear.

ST 899904100 REMOVER

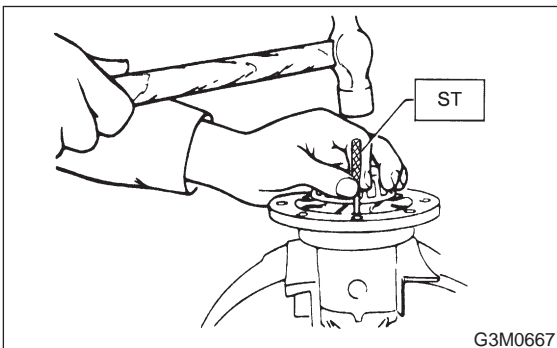

4) Pull out pinion shaft, and remove differential bevel pinion and gear and washer.

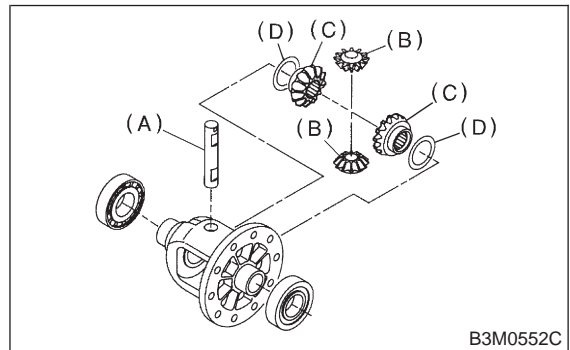

- (A) Pinion shaft
- (B) Bevel pinion
- (C) Bevel gear
- (D) Washer

5) Remove roller bearing using ST.
ST 399527700 PULLER SET

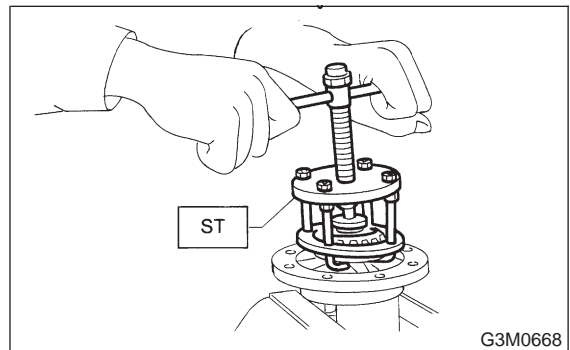

B: ASSEMBLY

1) Install bevel gear and bevel pinion together with washers, and insert pinion shaft.

NOTE:

Face the chamfered side of washer toward gear.

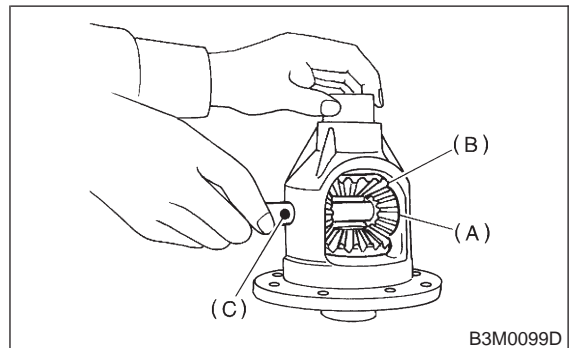

- (A) Bevel pinion
- (B) Bevel gear
- (C) Pinion shaft

3-1 [W6B0]

6. Front Differential

SERVICE PROCEDURE

2) Measure backlash between bevel gear and pinion. If it is not within specifications, install a suitable washer to adjust it.

NOTE:

Be sure the pinion gear tooth contacts adjacent gear teeth during measurement.

ST1 498247001 MAGNET BASE

ST2 498247100 DIAL GAUGE

Standard backlash:

0.13 — 0.18 mm (0.0051 — 0.0071 in)

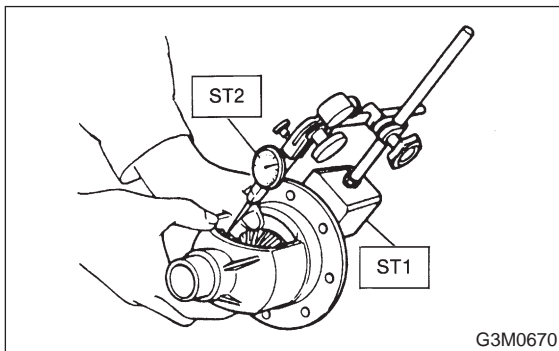

Washer (38.1 × 50 × t)	
Part No.	Thickness mm (in)
803038021	0.925 — 0.950 (0.0364 — 0.0374)
803038022	0.975 — 1.000 (0.0384 — 0.0394)
803038023	1.025 — 1.050 (0.0404 — 0.0413)

3) Align pinion shaft and differential case at their holes, and drive straight pin into holes from the hypoid driven gear side, using ST.

NOTE:

Lock straight pin after installing.

ST 899904100 REMOVER

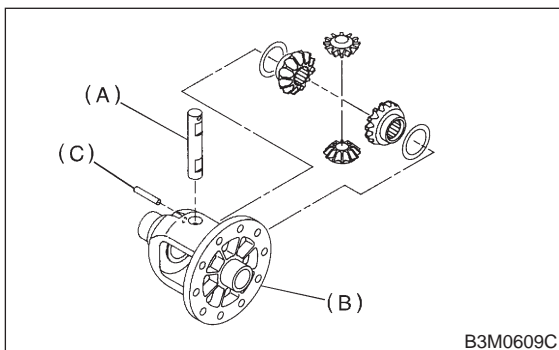

- (A) Pinion shaft
- (B) Differential case
- (C) Straight pin

4) Install roller bearing (40 × 80 × 19.75) to differential case.

NOTE:

Be careful because roller bearing outer races are used as a set.

ST1 499277100 BUSH 1-2 INSTALLER

ST2 398497701 ADAPTER

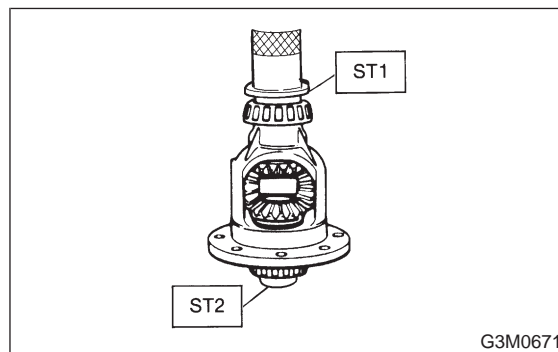

5) Install hypoid driven gear to differential case using twelve bolts.

Tightening torque:

T: 62±5 N·m (6.3±0.5 kg·m, 45.6±3.6 ft·lb)

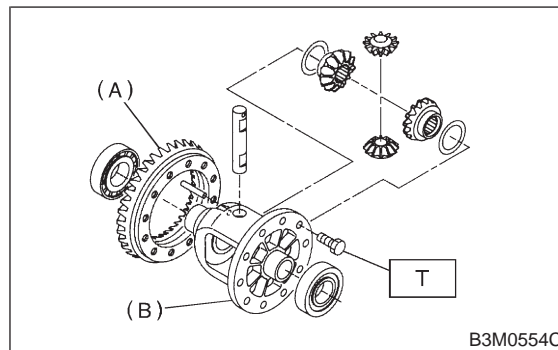

- (A) Hypoid driven gear
- (B) Differential case

6) Position drive axle shaft in differential case and hold it with outer snap ring (28). Using a thickness gauge, measure clearance between the shaft and case is within specifications.

NOTE:

If it is not within specifications, replace snap ring with a suitable one.

Clearance:

0 — 0.2 mm (0 — 0.008 in)

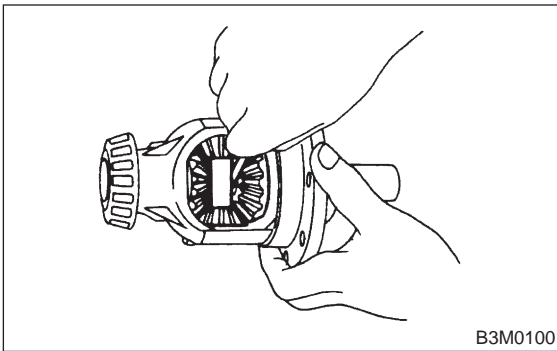

Snap ring (Outer-28)	
Part No.	Thickness mm (in)
805028011	1.05 (0.0413)
805028012	1.20 (0.0472)

7. Center Differential

A: DISASSEMBLY AND ASSEMBLY

1) Remove ball bearing using ST.

CAUTION:

Do not reuse ball bearing.

ST 498077300 CENTER DIFFERENTIAL BEARING REMOVER

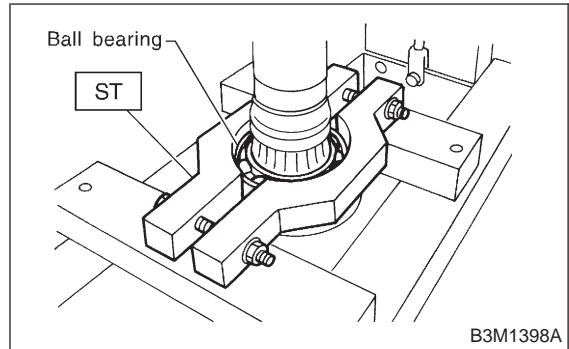

2) Install ball bearing to center differential assembly.

NOTE:

Do not disassemble center differential because it is a non-disassemble part.

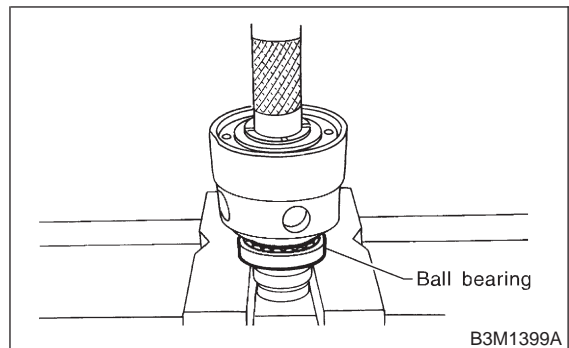

6) Position drive axle shaft in differential case and hold it with outer snap ring (28). Using a thickness gauge, measure clearance between the shaft and case is within specifications.

NOTE:

If it is not within specifications, replace snap ring with a suitable one.

Clearance:

0 — 0.2 mm (0 — 0.008 in)

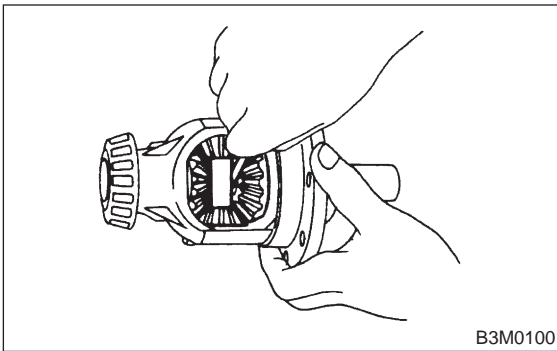

Snap ring (Outer-28)	
Part No.	Thickness mm (in)
805028011	1.05 (0.0413)
805028012	1.20 (0.0472)

7. Center Differential

A: DISASSEMBLY AND ASSEMBLY

1) Remove ball bearing using ST.

CAUTION:

Do not reuse ball bearing.

ST 498077300 CENTER DIFFERENTIAL BEARING REMOVER

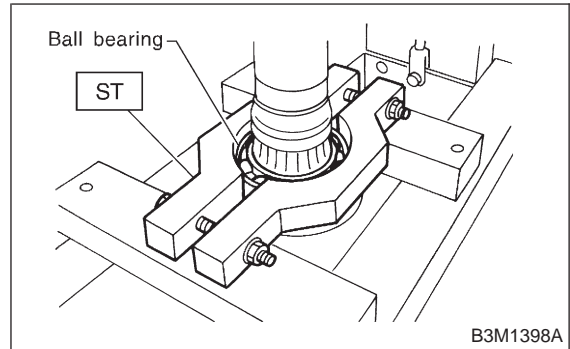

2) Install ball bearing to center differential assembly.

NOTE:

Do not disassemble center differential because it is a non-disassemble part.

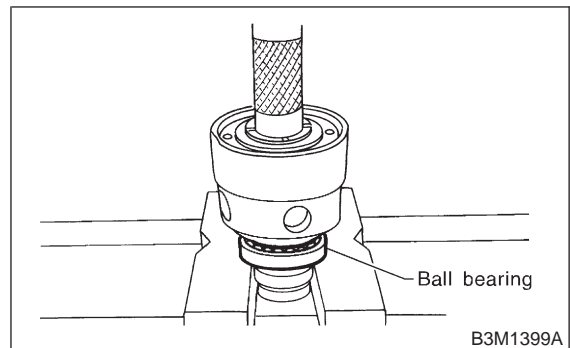

1. Manual Transmission

Symptom	Possible cause	Remedy
1. Gears are difficult to intermesh. NOTE: The cause for difficulty in shifting gears can be classified into two kinds: one is malfunction of the gear shift system and the other is malfunction of the transmission. However, if the operation is heavy and engagement of the gears is difficult, defective clutch disengagement may also be responsible. Check whether the clutch is correctly functioning, before checking the gear shift system and transmission.	(a) Worn, damaged or burred chamfer of internal spline of sleeve and reverse driven gear	Replace.
	(b) Worn, damaged or burred chamfer of spline of gears	Replace.
	(c) Worn or scratched bushings	Replace.
	(d) Incorrect contact between synchronizer ring and gear cone or wear	Correct or replace.
2. Gear slips out. ● Gear slips out when coasting on rough road. ● Gear slips out during acceleration.	(a) Defective pitching stopper adjustment	Adjust
	(b) Loose engine mounting bolts	Tighten or replace.
	(c) Worn fork shifter, broken shifter fork rail spring	Replace.
	(d) Worn or damaged ball bearing	Replace.
	(e) Excessive clearance between splines of synchronizer hub and synchronizer sleeve	Replace.
	(f) Worn tooth step of synchronizer hub (responsible for slip- out of 3rd gear)	Replace.
	(g) Worn 1st driven gear, needle bearing and race	Replace.
	(h) Worn 2nd driven gear, needle bearing and race	Replace.
	(i) Worn 3rd drive gear and bushing	Replace.
	(j) Worn 4th drive gear and bushing	Replace.
3. Unusual noise comes from transmission. NOTE: If an unusual noise is heard when the vehicle is parked with its engine idling and if the noise ceases when the clutch is disengaged, it may be considered that the noise comes from the transmission.	(k) Worn reverse idler gear and bushing	Replace.
	(a) Insufficient or improper lubrication	Lubricate or replace with specified oil.
	(b) Worn or damaged gears and bearings NOTE: If the trouble is only wear of the tooth surfaces, merely a high roaring noise will occur at high speeds, but if any part is broken, rhythmical knocking sound will be heard even at low speeds.	Replace.

2. Differential

Symptom	Possible cause	Remedy
<p>1. Broken differential (case, gear, bearing, etc.) NOTE: Abnormal noise will develop and finally it will become impossible to continue to run due to broken pieces obstructing the gear revolution.</p>	(a) Insufficient or improper oil	Disassemble differential and replace broken components and at the same time check other components for any trouble, and replace if necessary
	(b) Use of vehicle under severe conditions such as excessive load and improper use of clutch	Readjust bearing preload and backlash and face contact of gears.
	(c) Improper adjustment of taper roller bearing	Adjust.
	(d) Improper adjustment of drive pinion and hypoid driven gear	Adjust.
	(e) Excessive backlash due to worn differential side gear, washer or differential pinion vehicle under severe operating conditions.	Add recommended oil to specified level. Do not use vehicle under severe operating conditions.
	(f) Loose hypoid driven gear clamping bolts	Tighten.
<p>2. Differential and hypoid gear noises Troubles of the differential and hypoid gear always appear as noise problems. Therefore noise is the first indication of the trouble. However noises from the engine, muffler, tire, exhaust gas, bearing, body, etc. are easily mistaken for the differential noise. Pay special attention to the hypoid gear noise because it is easily confused with other gear noises. There are the following four kinds of noises.</p> <ul style="list-style-type: none"> ● Gear noise when driving: If noise increases as vehicle speed increases it may be due to insufficient gear oil, incorrect gear engagement, damaged gears, etc. ● Gear noise when coasting: Damaged gears due to maladjusted bearings and incorrect shim adjustment ● Bearing noise when driving or when coasting: Cracked, broken or damaged bearings ● Noise which mainly occurs when turning: Unusual noise from differential side gear, differential pinion, differential pinion shaft, etc. 	(a) Insufficient oil	Lubricate.
	(b) Improper adjustment of hypoid driven gear and drive pinion	Check tooth contact.
	(c) Worn teeth of hypoid driven gear and drive pinion	Replace as a set. Readjust bearing preload.
	(d) Loose roller bearing	Readjust hypoid driven gear to drive pinion backlash and check tooth contact.
	(e) Distorted hypoid driven gear or differential case	Replace.
	(f) Worn washer and differential pinion shaft	Replace.

MEMO:

1. Automatic Transmission and Differential

A: SPECIFICATIONS

Torque converter clutch	Type		Symmetric, 3 element, single stage, 2 phase torque converter		
	Stall torque ratio	2200 cc	2.1 — 2.3		
		2500 cc	1.8 — 2.0		
		OUTBACK	2.2 — 2.4		
	Nominal diameter	2200 cc	236 mm (9.29 in)		
		2500 cc	246 mm (9.69 in)		
	Stall speed (at sea level)	2200 cc	2,200 — 2,600 rpm		
2500 cc		2,200 — 2,600 rpm			
OUTBACK		2,300 — 2,700 rpm			
One-way clutch		Sprague type one-way clutch			
Automatic transmission	Transmission	Type	4-forward, 1-reverse, double-row planetary gears		
		Control element	Multi-plate clutch		3 sets
			Multi-plate brake		2 sets
			One-way clutch (sprague type)		1 set
		Gear ratio	1st	2200 cc	2.785
				2500 cc	3.027
			2nd	2200 cc	1.545
				2500 cc	1.619
			3rd		1.000
			4th		0.694
			Reverse		2.272
		Tooth number of planetary gear	Front sun gear		33
			Front pinion		21
			Front internal gear		75
			Rear sun gear	2200 cc	42
				2200 cc	37
			Rear pinion	2200 cc	17
				2500 cc	19
			Rear internal gear		75
			Plate number of high clutch		Drive plate & driven plate
Plate number of reverse clutch		Drive plate & driven plate	2		
Plate number of 2-4 brake		Drive plate & driven plate	3		
Plate number of low clutch	Drive plate & driven plate	2200 cc	5		
		2500 cc	6		
Plate number of low & reverse brake	Drive plate & driven plate	2200 cc	5		
		2500 cc	6		

SPECIFICATIONS AND SERVICE DATA

[S1A0] 3-2











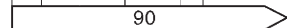

1. Automatic Transmission and Differential

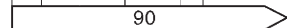
Automatic transmission	Transmission	Selector position		P (Park)	Transmission in neutral, output member immovable, and engine start possible		
				R (Reverse)	Transmission in reverse for backing		
				N (Neutral)	Transmission in neutral, and engine start possible		
				D (Drive)	Automatic gear change 1st ← → 2nd ← → 3rd ← → 4th		
				3 (3rd)	Automatic gear change 1st ← → 2nd ← → 3rd ← 4th		
				2 (2nd)	2nd gear locked (Deceleration possible 4th → 3rd → 2nd)		
				1 (1st)	1st gear locked (Deceleration possible 4th → 3rd → 2nd → 1st)		
	Oil pump	Control method		Hydraulic remote control			
		Type		Trochoid constant-displacement pump			
		Driving method		Driven by engine			
		Number of teeth		Inner rotor	9		
	Outer rotor			10			
	Hydraulic control	Type		Electronic/hydraulic control [Four forward speed changes by electrical signals of vehicle speed and accelerator (throttle) opening]			
		Fluid		Dexron II or Dexron III type Automatic transmission fluid			
		Fluid capacity	2200 cc	8.4 — 8.7 ℓ (8.9 — 9.2 US qt, 7.4 — 7.7 Imp qt)			
	2500 cc		9.3 — 9.6 ℓ (9.8 — 10.1 US qt, 8.2 — 8.4 Imp qt)				
	Lubrication	Lubrication system		Forced feed lubrication with oil pump			
		Oil		Automatic transmission fluid (above mentioned.)			
	Cooling	Cooling system		Liquid-cooled cooler incorporated in radiator			
	Harness	Inhibitor switch		12 poles			
		Transmission harness		17 poles			
	Transfer	Transfer clutch		Hydraulic multi-plate clutch			
		Plate number of transfer clutch	Drive plate & driven plate	2200 cc	4		
				2500 cc	5		
		Control method		Electronic, hydraulic type			
		Lubricant		The same Automatic Transmission Fluid used in automatic transmission.			
	1st reduction gear ratio		1.000 (53/53)				

3-2 [S1A0]

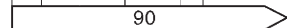
SPECIFICATIONS AND SERVICE DATA

1. Automatic Transmission and Differential

Final reduction	Final gear ratio	Front drive	2200 cc	4.111 (37/9)														
			2500 cc	4.444 (40/9)														
	Lubrication oil	<p style="text-align: center;">ITEM</p> <p style="text-align: center;">• Front differential gear oil</p> <p style="text-align: center;">API Classification</p> <p style="text-align: center;">GL - 5</p> <table border="1" style="width: 100%; border-collapse: collapse;"> <thead> <tr> <th colspan="2">SAE Viscosity No. and Applicable Temperature</th> </tr> <tr> <th>(°C)</th> <th>-30 -26 -15 -5 0 15 25 30</th> </tr> <tr> <th>(°F)</th> <th>-22 -15 5 23 32 59 77 86</th> </tr> </thead> <tbody> <tr> <td style="text-align: center;">90</td> <td style="text-align: center;">  </td> </tr> <tr> <td style="text-align: center;">85W</td> <td style="text-align: center;">  </td> </tr> <tr> <td style="text-align: center;">80W</td> <td style="text-align: center;">  </td> </tr> <tr> <td style="text-align: center;">80W-90</td> <td style="text-align: center;">  </td> </tr> </tbody> </table> <p style="text-align: right;">H3M1235A</p>			SAE Viscosity No. and Applicable Temperature		(°C)	-30 -26 -15 -5 0 15 25 30	(°F)	-22 -15 5 23 32 59 77 86	90		85W		80W		80W-90	
	SAE Viscosity No. and Applicable Temperature																	
	(°C)	-30 -26 -15 -5 0 15 25 30																
(°F)	-22 -15 5 23 32 59 77 86																	
90																		
85W																		
80W																		
80W-90																		
Oil capacity	Front drive	1.2 ℓ (1.3 US qt, 1.1 Imp qt)																
ATF cooling system	Radiation capacity	1.977 kW (1,700 kcal/h, 6,746 BTU/h)																

MEMO:

B: ADJUSTING PARTS

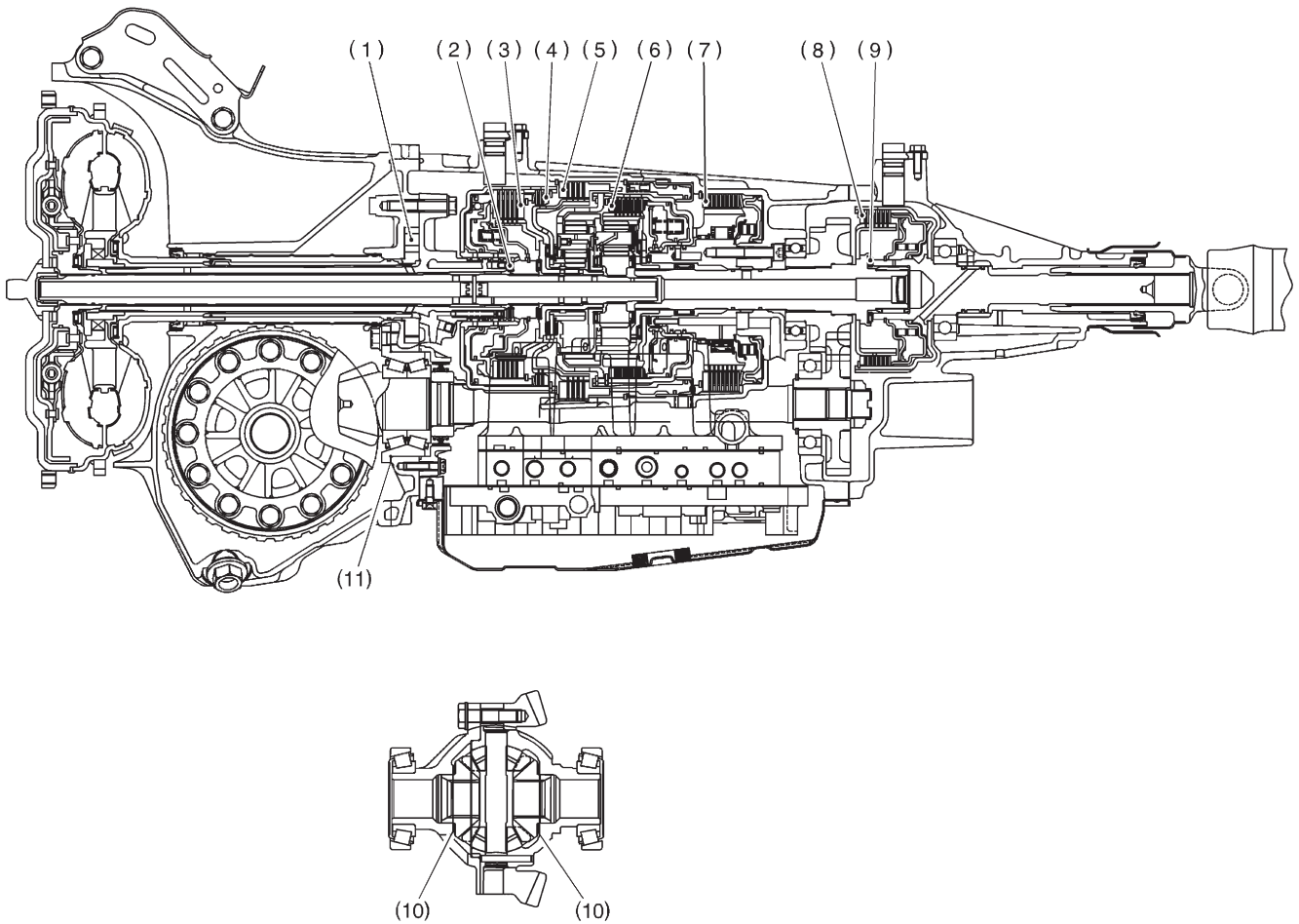

SPECIFICATIONS AND SERVICE DATA

[S1B0] 3-2

1. Automatic Transmission and Differential

No.	Part Name	Part Number	Dimension mm (in)	Application
1	Rotor (Oil pump)	15008AA060 15008AA070 15008AA080	11.37 — 11.38 (0.4476 — 0.4480) 11.38 — 11.39 (0.4480 — 0.4484) 11.39 — 11.40 (0.4484 — 0.4488)	Adjusting side clearance of oil pump
2	Thrust bearing	806528050 806528060 806528070 806528080 806528090 806528100	4.11 (0.1618) 4.3 (0.169) 4.5 (0.177) 4.7 (0.185) 4.9 (0.193) 5.1 (0.201)	Adjusting total end play
3	Retaining plate (High clutch)	31567AA710 31567AA720 31567AA730 31567AA740 31567AA670 31567AA680 31567AA690 31567AA700	4.7 (0.185) 4.8 (0.189) 4.9 (0.193) 5.0 (0.197) 5.1 (0.201) 5.2 (0.205) 5.3 (0.209) 5.4 (0.213)	Adjusting clearance of high clutch
4	Retaining plate (Reverse clutch)	31567AA750 31567AA760 31567AA770 31567AA780 31567AA790 31567AA800 31567AA810 31567AA820	3.8 (0.150) 4.0 (0.157) 4.2 (0.165) 4.4 (0.173) 4.6 (0.181) 4.8 (0.189) 5.0 (0.197) 5.2 (0.205)	Adjusting clearance of reverse clutch
5	Retaining plate (2-4 brake)	31567AA610 31567AA620 31567AA630 31567AA640 31567AA650 31567AA660	5.6 (0.220) 5.8 (0.228) 6.0 (0.236) 6.2 (0.244) 6.4 (0.252) 6.6 (0.260)	Adjusting clearance of 2-4 brake
6	Retaining plate (Low clutch)	31567AA830 31567AA840 31567AA850 31567AA860 31567AA870	3.8 (0.150) 4.0 (0.157) 4.2 (0.165) 4.4 (0.173) 4.6 (0.181)	Adjusting clearance of low clutch
7	Retaining plate (Low and reverse brake)	31667AA320 31667AA330 31667AA340 31667AA350 31667AA360 31667AA370 31667AA380	4.2 (0.165) 4.5 (0.177) 4.8 (0.189) 5.1 (0.201) 5.4 (0.213) 5.7 (0.224) 6.0 (0.236)	Adjusting clearance of low and reverse brake
8	Pressure plate (Transfer clutch)	31593AA151 31593AA161 31593AA171 31593AA181	3.3 (0.130) 3.7 (0.146) 4.1 (0.161) 4.5 (0.177)	Adjusting clearance of transfer clutch
9	Thrust bearing (Transfer clutch)	806536020 806535030 806535040 806535050 806535060 806535070 806535090	3.8 (0.150) 4.0 (0.157) 4.2 (0.165) 4.4 (0.173) 4.6 (0.181) 4.8 (0.189) 5.0 (0.197)	Adjusting end play of transfer clutch
10	Washer (Front differential)	803038021 803038022 803038023	0.95 (0.0374) 1.00 (0.0394) 1.05 (0.0413)	Adjusting backlash of differential bevel gear

3-2 [S1B0]**SPECIFICATIONS AND SERVICE DATA**1. Automatic Transmission and Differential

No.	Part Name	Part Number	Dimension mm (in)	Application
11	Drive pinion shim	31451AA050	0.150 (0.0059)	Adjusting drive pinion shim
		31451AA060	0.175 (0.0069)	
		31451AA070	0.200 (0.0079)	
		31451AA080	0.225 (0.0089)	
		31451AA090	0.250 (0.0098)	
		31451AA100	0.275 (0.0108)	

MEMO:

C: LOCATION AND INSTALLING DIRECTION OF THRUST NEEDLE BEARING

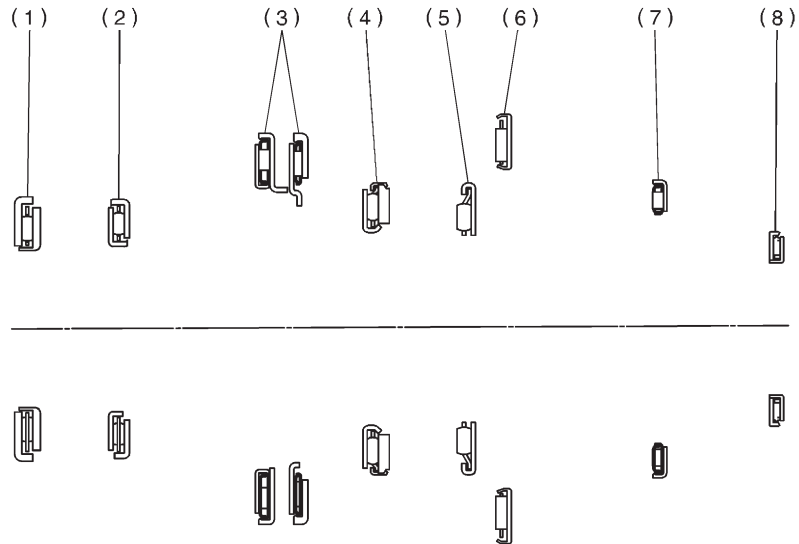
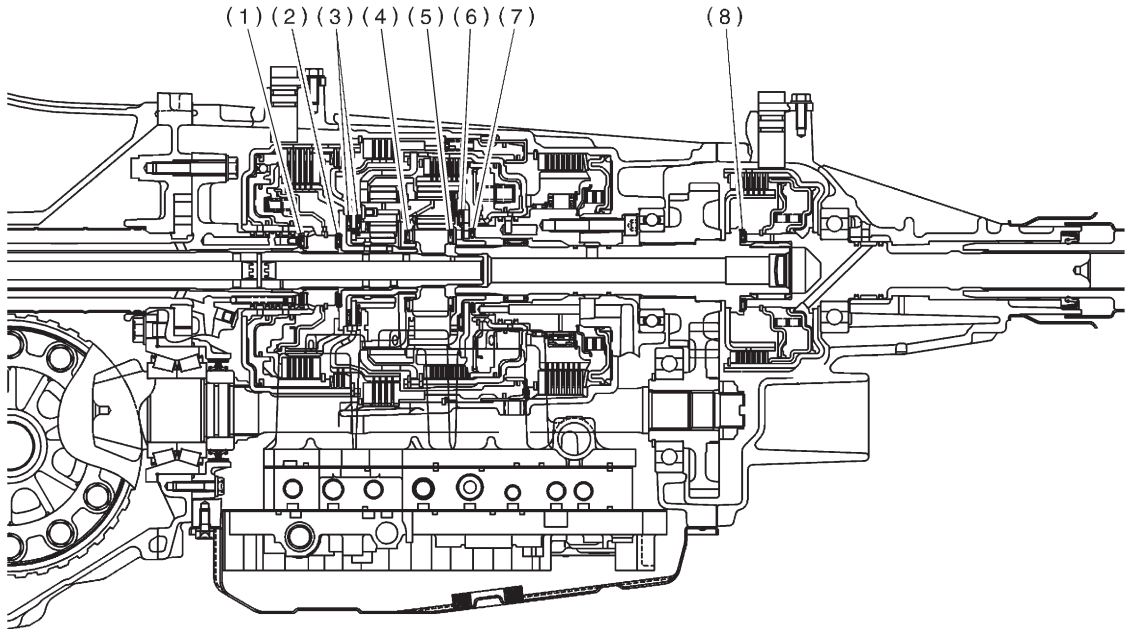

SPECIFICATIONS AND SERVICE DATA

[S1D1] 3-2

1. Automatic Transmission and Differential

No.	Part Name	Part Number	Inside diameter mm (in)	Outside diameter mm (in)	Dimension mm (in)	Application
(1)	Thrust needle bearing	806528050 806528060 806528070 806528080 806528090 806528100	28.5 (1.122)	48 (1.89)	4.1 (0.161) 4.3 (0.169) 4.5 (0.177) 4.7 (0.185) 4.9 (0.193) 5.1 (0.201)	Adjusting total end play
(2)	Thrust needle bearing	806530040	30 (1.18)	47 (1.85)	3.8 (0.150)	Place of high clutch
(3)	Thrust needle bearing	806551020	51 (2.01)	71 (2.80)	3.3 (0.130)	Place of front sun gear
(4)	Thrust needle bearing	806535120	35 (1.38)	53 (2.09)	4.8 (0.189)	Place of rear sun gear
(5)	Thrust needle bearing	806534060	35 (1.38)	53 (2.09)	3.3 (0.130)	Place of rear sun gear
(6)	Thrust needle bearing	806558030	58 (2.28)	78 (3.07)	2.8 (0.110)	Place of rear internal gear
(7)	Thrust needle bearing	806541020	39.7 (1.563)	54 (2.13)	3.6 (0.142)	Place of one-way clutch
(8)	Thrust needle bearing	806536020 806535030 806535040 806535050 806535060 806535070 806535090	36 (1.42)	53 (2.09)	3.8 (0.150) 4.0 (0.157) 4.2 (0.165) 4.4 (0.173) 4.6 (0.181) 4.8 (0.189) 5.0 (0.197)	Adjusting end play of transfer clutch

D: FLUID PASSAGES

1. TRANSMISSION CASE (FRONT SIDE)

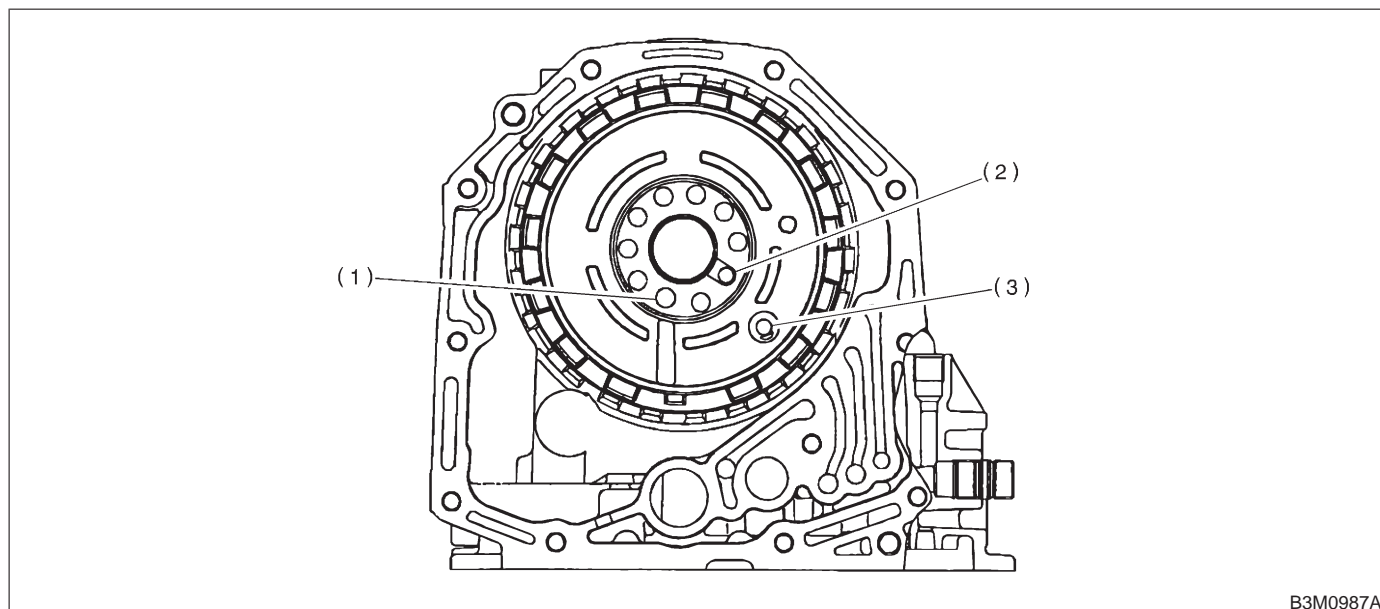

(1) Low clutch pressure

(2) Oil cooler inlet pressure

(3) Low & reverse brake pressure

3-2 [S1D2]

SPECIFICATIONS AND SERVICE DATA

1. Automatic Transmission and Differential

2. TRANSMISSION CASE (LH SIDE)

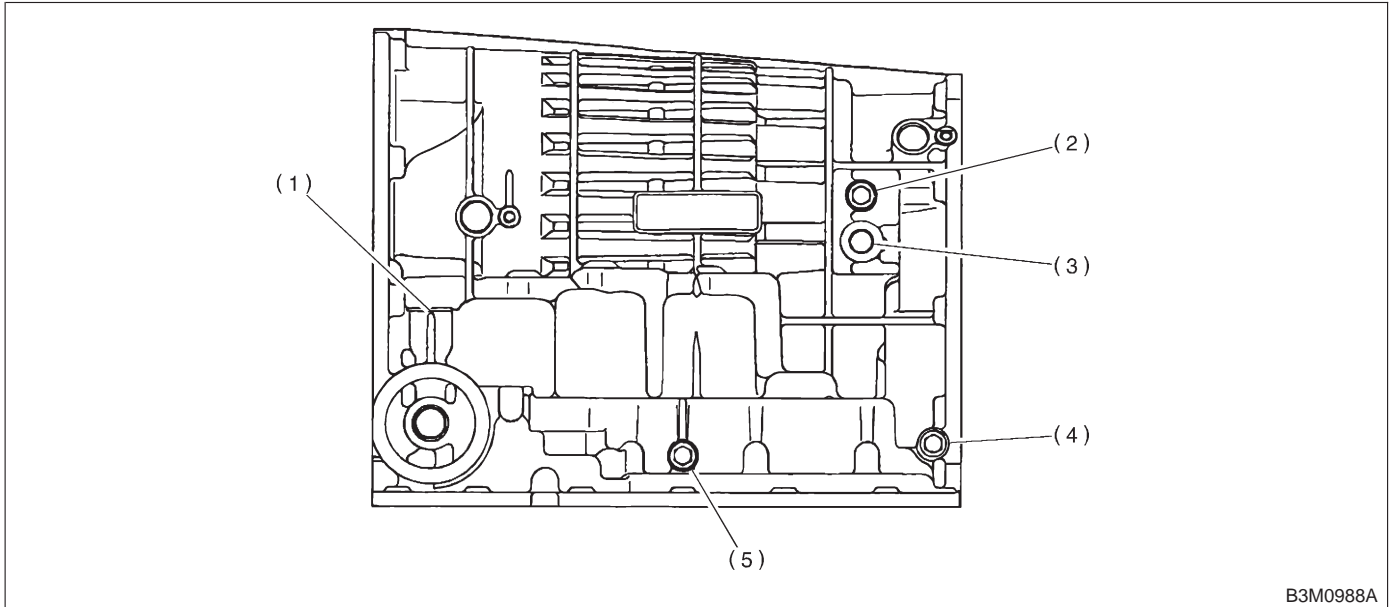

B3M0988A

- | | | |
|----------------------------------|-------------------------------|------------------------|
| (1) Oil cooler outlet pressure | (3) Oil cooler inlet pressure | (5) 2-4 brake pressure |
| (2) Low & reverse brake pressure | (4) Low clutch pressure | |

3. TRANSMISSION CASE (REAR SIDE)

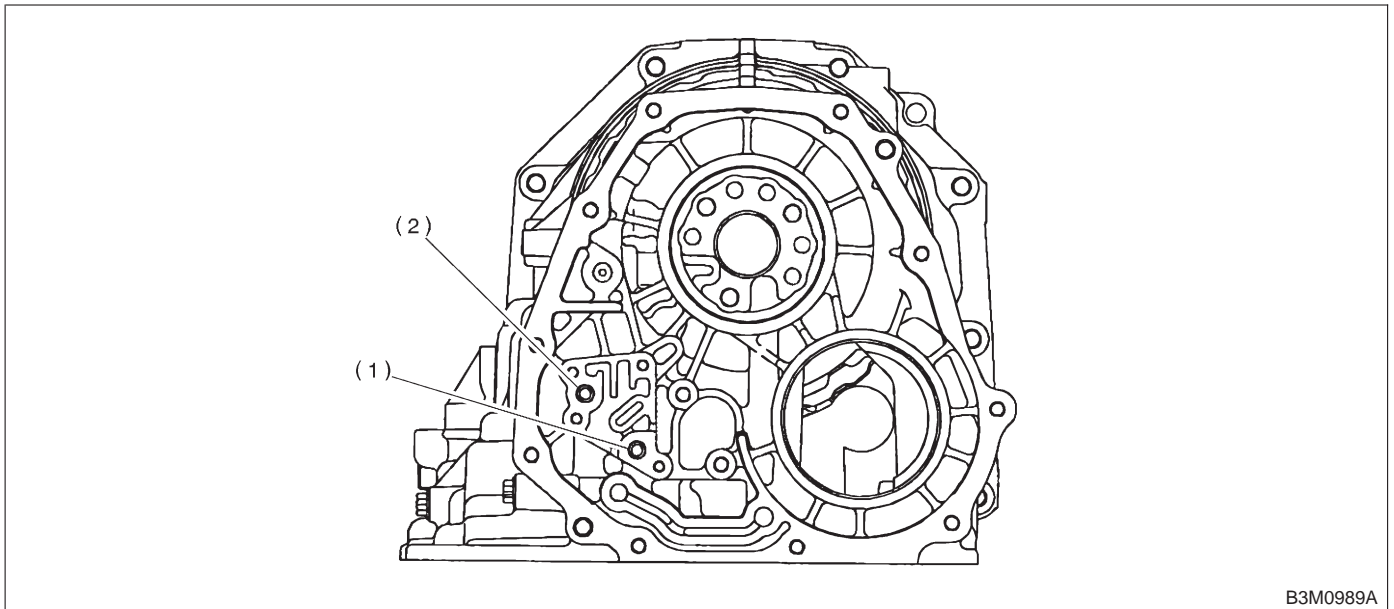

B3M0989A

- | | |
|--------------------|-------------------|
| (1) Pilot pressure | (2) Line pressure |
|--------------------|-------------------|

4. OIL PUMP COVER

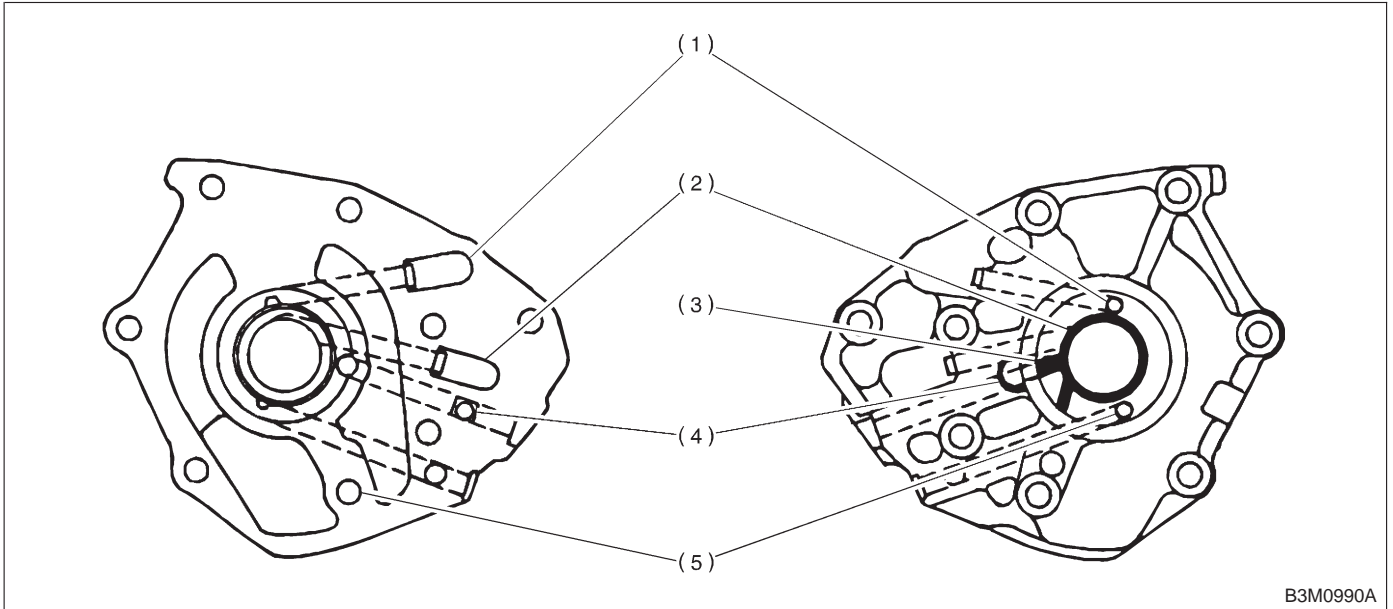

B3M0990A

- | | | |
|------------------------------|----------------------------|-----------------------------|
| (1) High clutch pressure | (3) Front lubricating hole | (5) Reverse clutch pressure |
| (2) Lock-up release pressure | (4) Lock-up apply pressure | |

5. OIL PUMP HOUSING

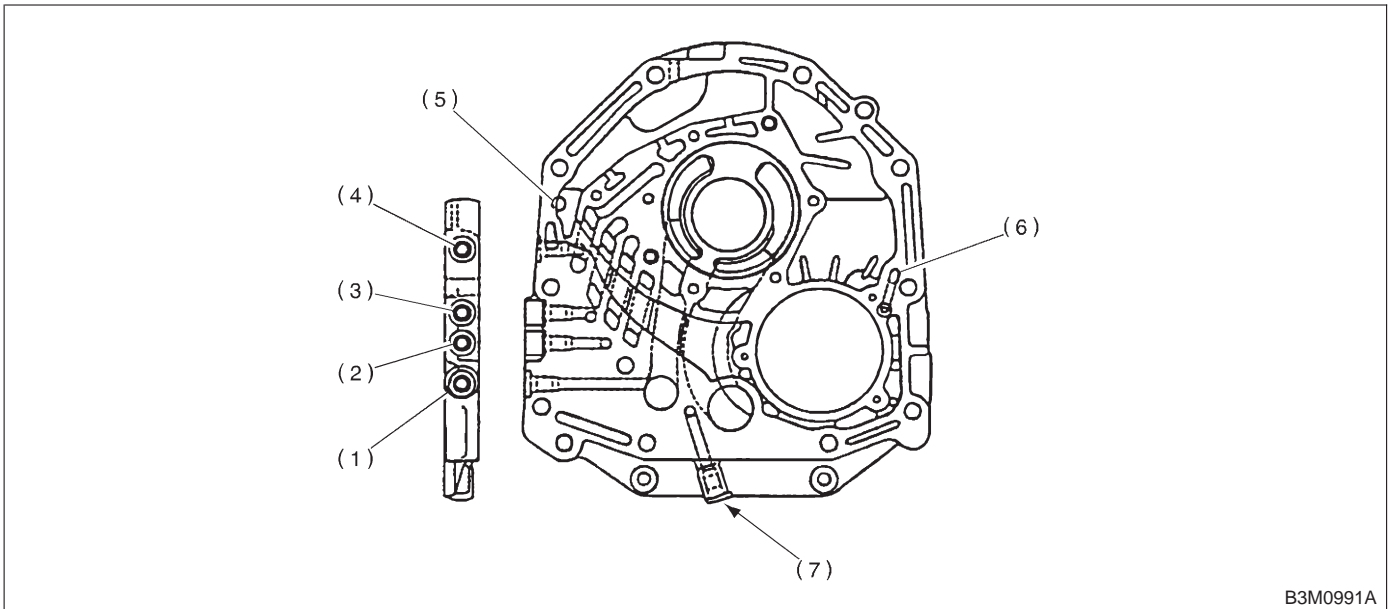

B3M0991A

- | | | |
|------------------------------|--------------------------|-----------------------------|
| (1) Oil pump outlet pressure | (4) High clutch pressure | (7) Reverse clutch pressure |
| (2) Lock-up apply pressure | (5) Drain | |
| (3) Lock-up release pressure | (6) Air breather | |

6. TRANSMISSION CASE

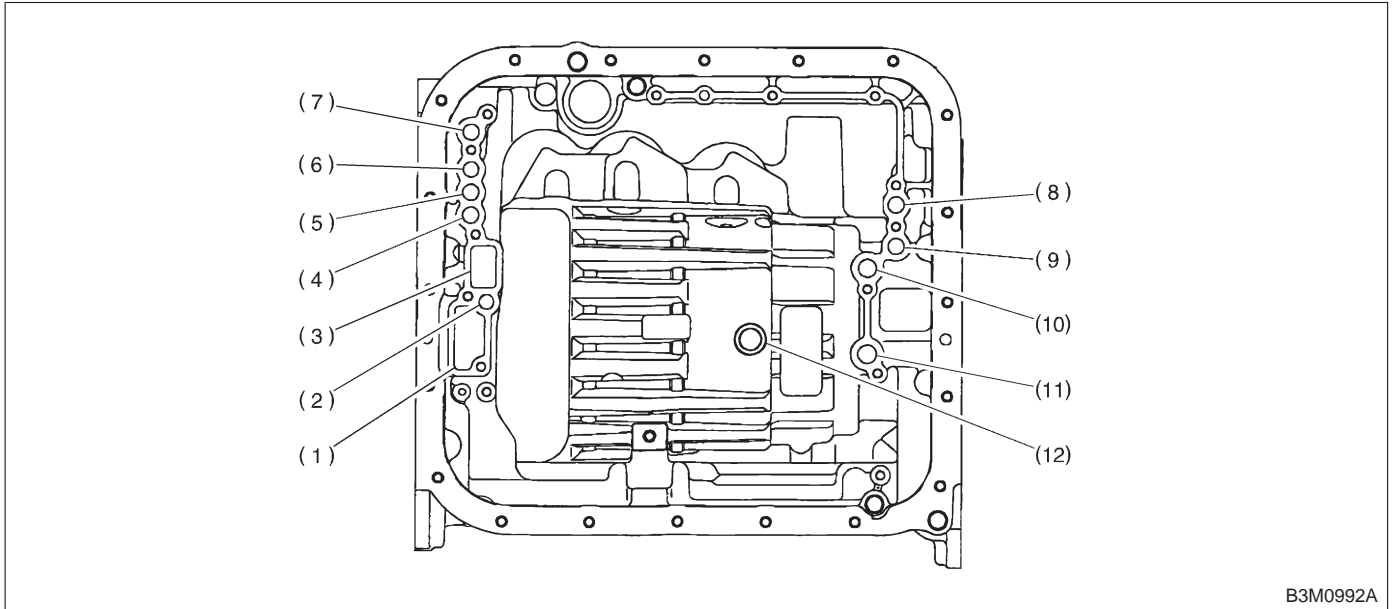

B3M0992A

- | | | |
|-----------------------------|--------------------------------|-----------------------------------|
| (1) Oil pump inlet port | (5) Lock-up release pressure | (9) Pilot pressure |
| (2) Reverse clutch pressure | (6) High clutch pressure | (10) Low & reverse brake pressure |
| (3) Oil pump outlet port | (7) Oil cooler outlet pressure | (11) Low clutch pressure |
| (4) Lock-up apply pressure | (8) Line pressure | (12) 2-4 brake pressure |

7. EXTENSION CASE

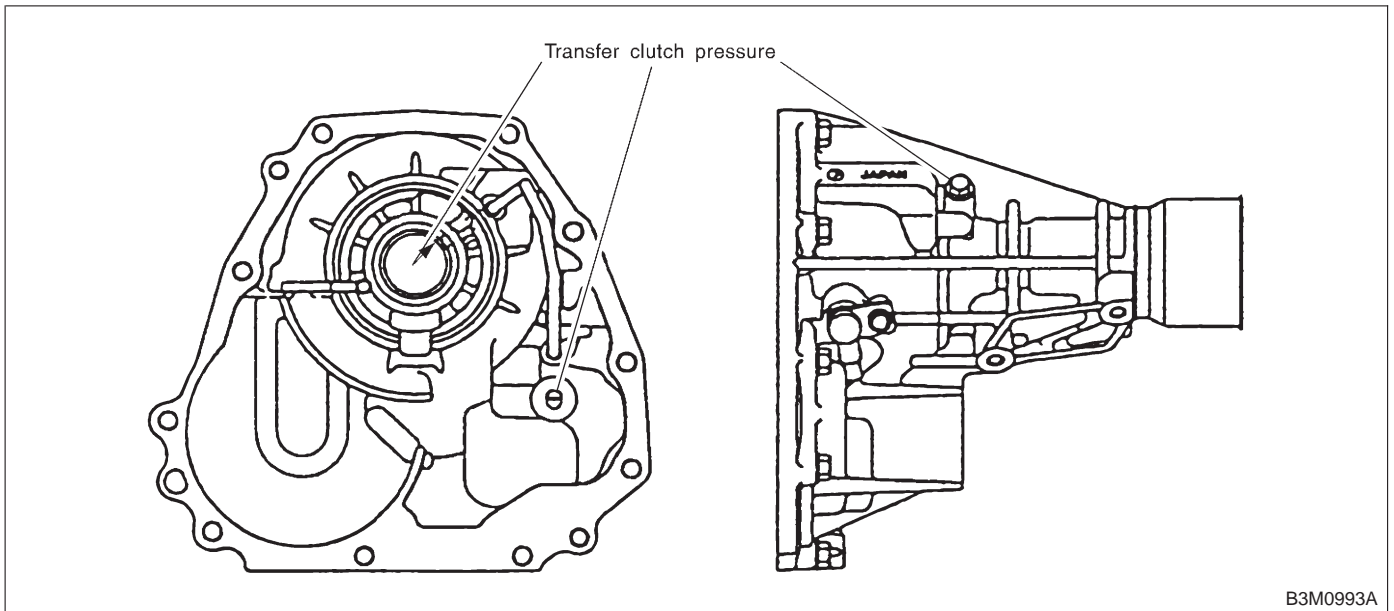

B3M0993A

1. Torque Converter Clutch and Case

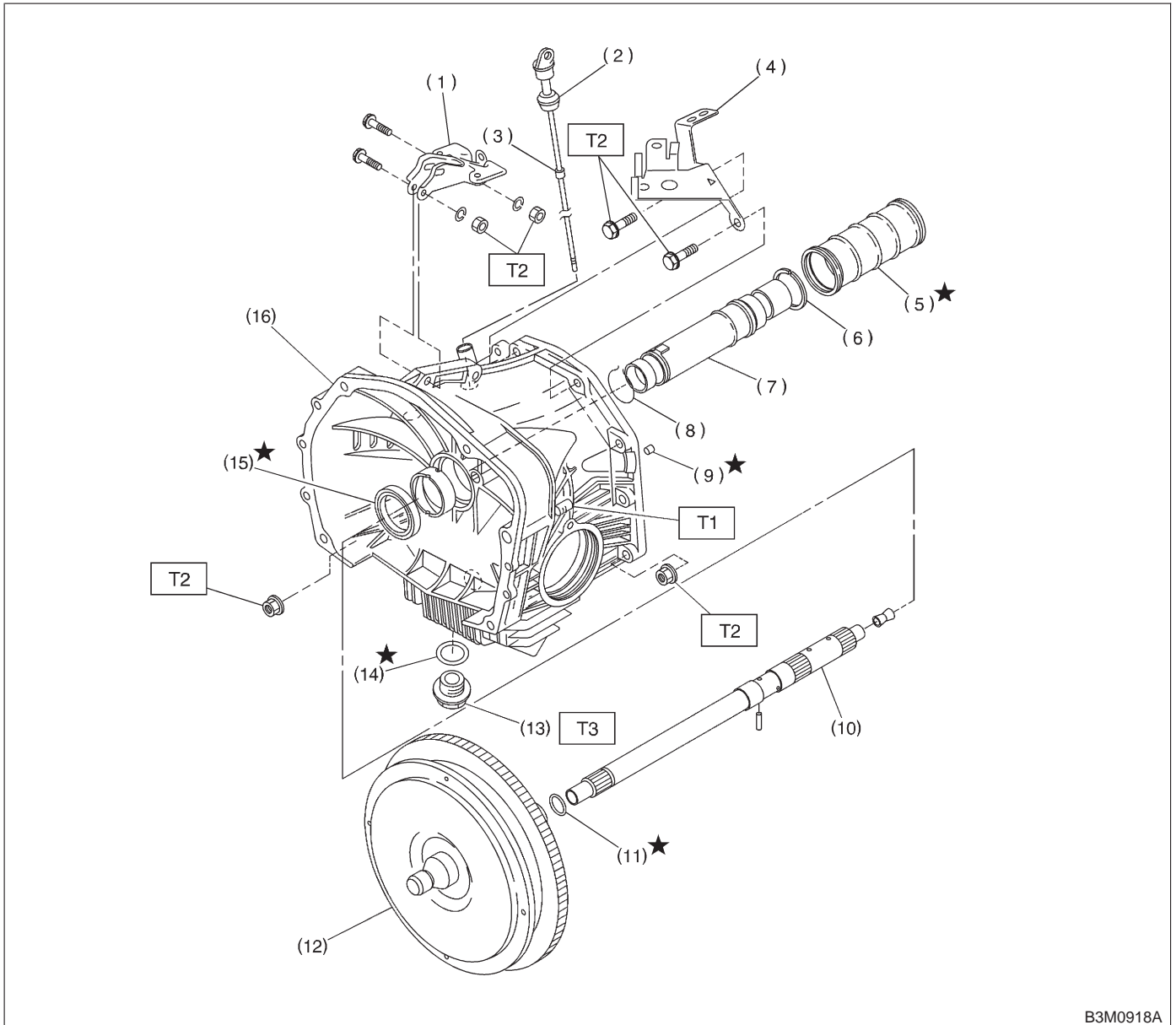

B3M0918A

- | | |
|----------------------------------|-----------------------------------|
| (1) Pitching stopper bracket | (9) Oil drain pipe |
| (2) O-ring | (10) Input shaft |
| (3) Differential oil level gauge | (11) O-ring |
| (4) Stay | (12) Torque converter clutch |
| (5) Seal pipe | (13) Drain plug |
| (6) Seal ring | (14) Gasket |
| (7) Oil pump shaft | (15) Oil seal |
| (8) Clip | (16) Torque converter clutch case |

Tightening torque: N-m (kg-m, ft-lb)

T1: 18±5 (1.8±0.5, 13.0±3.6)

T2: 41±3 (4.2±0.3, 30.4±2.2)

T3: 44±3 (4.5±0.3, 32.5±2.2)

2. Oil Pump

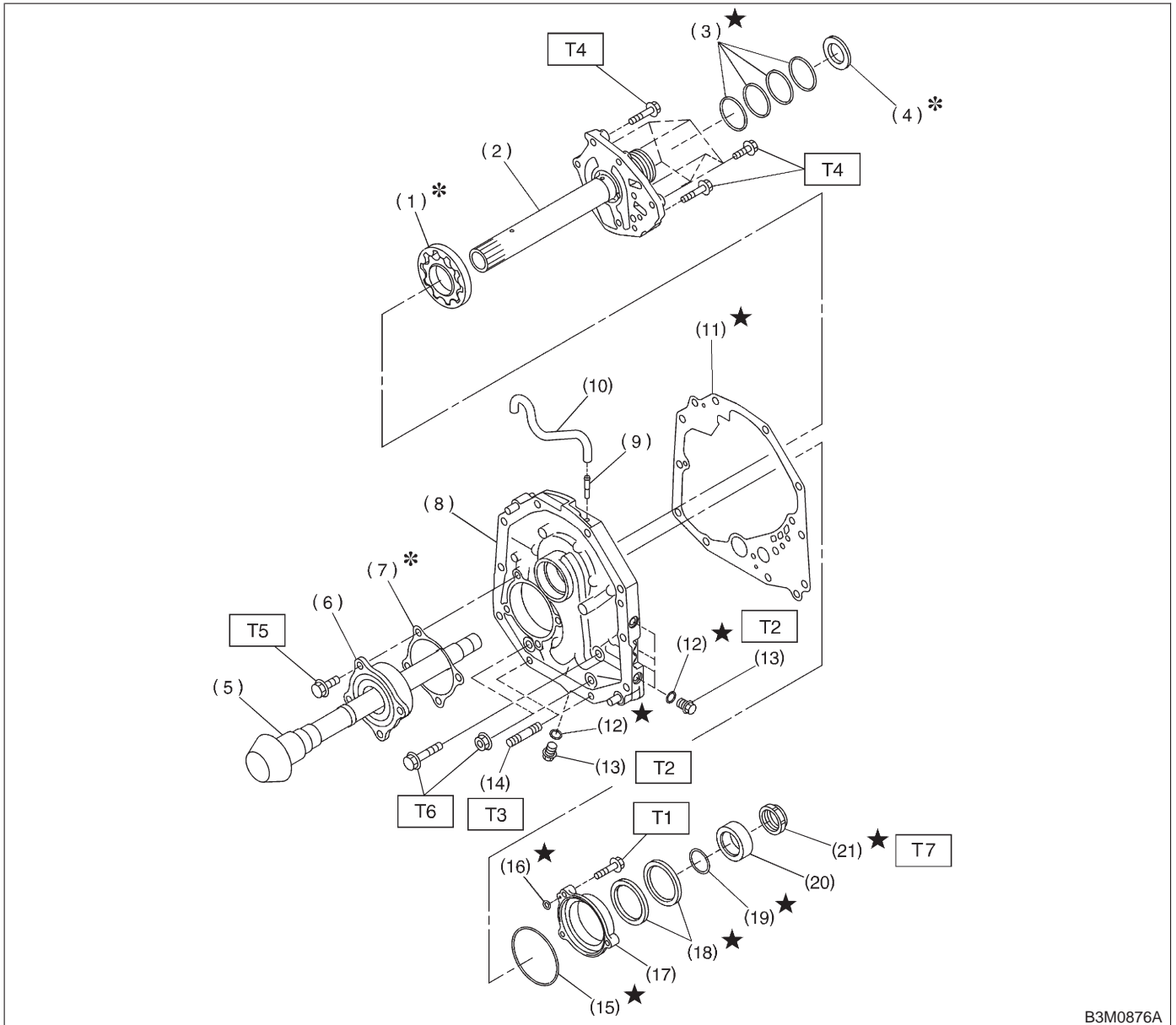

B3M0876A

- | | |
|---------------------------|--------------------------|
| (1) Oil pump rotor | (12) O-ring |
| (2) Oil pump cover | (13) Test plug |
| (3) Seal ring | (14) Stud bolt |
| (4) Thrust needle bearing | (15) O-ring |
| (5) Drive pinion shaft | (16) O-ring |
| (6) Roller bearing | (17) Oil seal retainer |
| (7) Shim | (18) Oil seal |
| (8) Oil pump housing | (19) O-ring |
| (9) Nipple | (20) Drive pinion collar |
| (10) Air breather hose | (21) Lock nut |
| (11) Gasket | |

Tightening torque: N-m (kg-m, ft-lb)

T1: 7±1 (0.7±0.1, 5.1±0.7)

T2: 13±1 (1.3±0.1, 9.4±0.7)

T3: 18±5 (1.8±0.5, 13.0±3.6)

T4: 25±2 (2.5±0.2, 18.1±1.4)

T5: 39±3 (4.0±0.3, 28.9±2.2)

T6: 41±3 (4.2±0.3, 30.4±2.2)

T7: 121±5 (12.3±0.5, 89.0±3.6)

COMPONENT PARTS

[C200] 3-2
2. Oil Pump

MEMO:

3. Transmission Case and Control Device

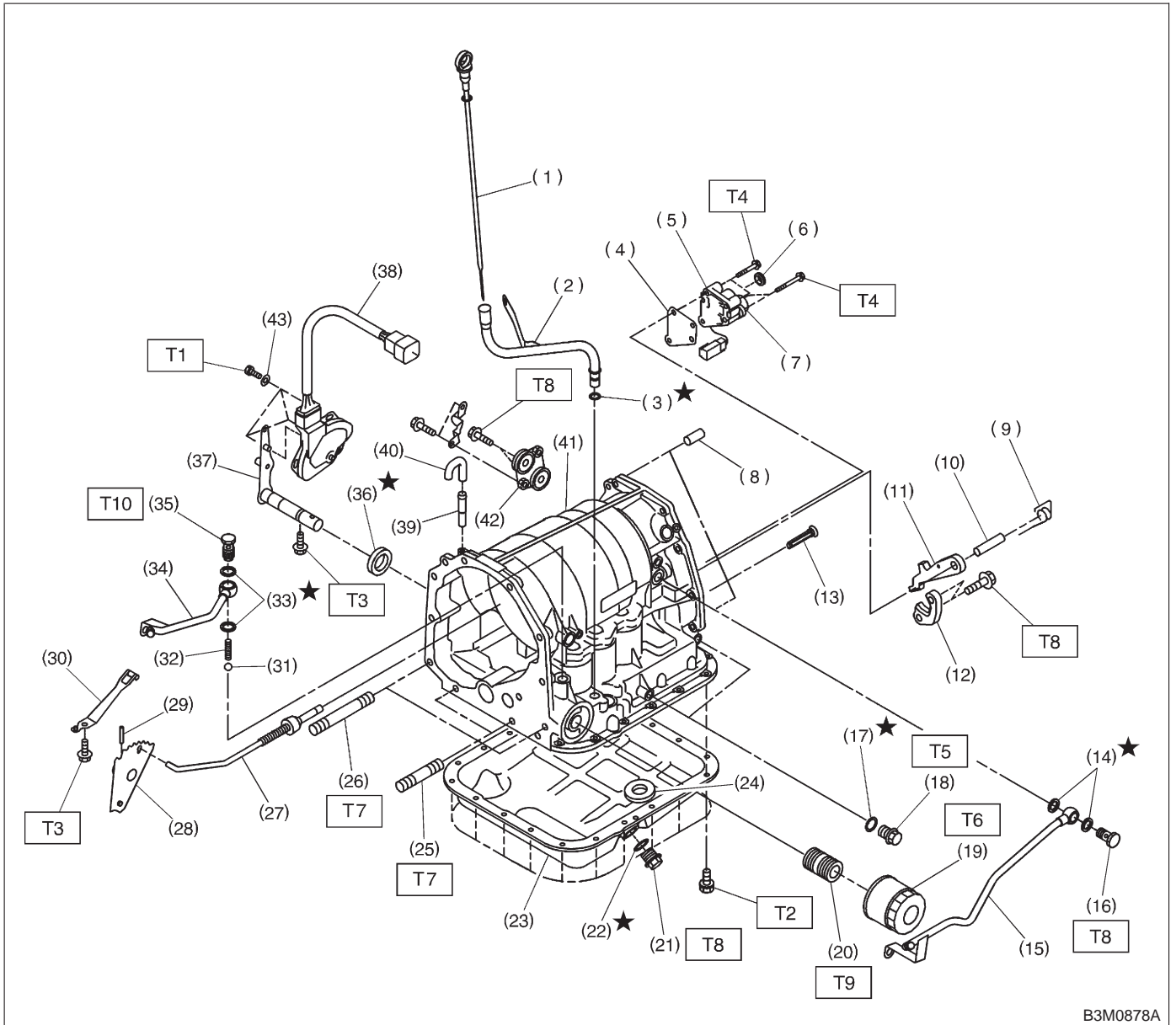

COMPONENT PARTS

[C300] 3-2

3. Transmission Case and Control Device

- (1) Oil level gauge
- (2) Oil charger pipe
- (3) O-ring
- (4) Transfer valve plate
- (5) Transfer valve ASSY
- (6) Transfer clutch seal
- (7) Duty solenoid C (Transfer)
- (8) Straight pin
- (9) Return spring
- (10) Shaft
- (11) Parking pawl
- (12) Parking support
- (13) Inlet filter
- (14) Gasket
- (15) Inlet pipe
- (16) Union screw
- (17) O-ring
- (18) Test plug
- (19) Oil filter
- (20) Oil filter stud bolt
- (21) Drain plug
- (22) Gasket
- (23) Oil pan
- (24) Magnet
- (25) Stud bolt (Short)
- (26) Stud bolt (Long)
- (27) Parking rod
- (28) Manual plate
- (29) Spring pin
- (30) Detention spring
- (31) Ball
- (32) Spring
- (33) Gasket
- (34) Outlet pipe
- (35) Union screw
- (36) Oil seal
- (37) Select lever
- (38) Inhibitor switch ASSY

- (39) Nipple
- (40) Air breather hose
- (41) Transmission case
- (42) Plate ASSY
- (43) Washer

Tightening torque: N-m (kg-m, ft-lb)

T1: 3.4±0.5 (0.35±0.05, 2.5±0.4)

T2: 4.9±0.5 (0.50±0.05, 3.6±0.4)

T3: 5.9±1.0 (0.60±0.10, 4.3±0.7)

T4: 7.8±1.0 (0.80±0.10, 5.8±0.7)

T5: 12.7±1.0 (1.30±0.10, 9.4±0.7)

T6: 13.7±2.0 (1.4±0.2, 10.1±1.4)

T7: 17.7±2.9 (1.80±0.30, 13.0±2.2)

T8: 24.5±2.0 (2.50±0.20, 18.1±1.4)

T9: 24.5±2.9 (2.5±0.3, 18.1±2.2)

T10: 34.3±2.9 (3.50±0.30, 25.3±2.2)

4. Control Valve and Harness Routing

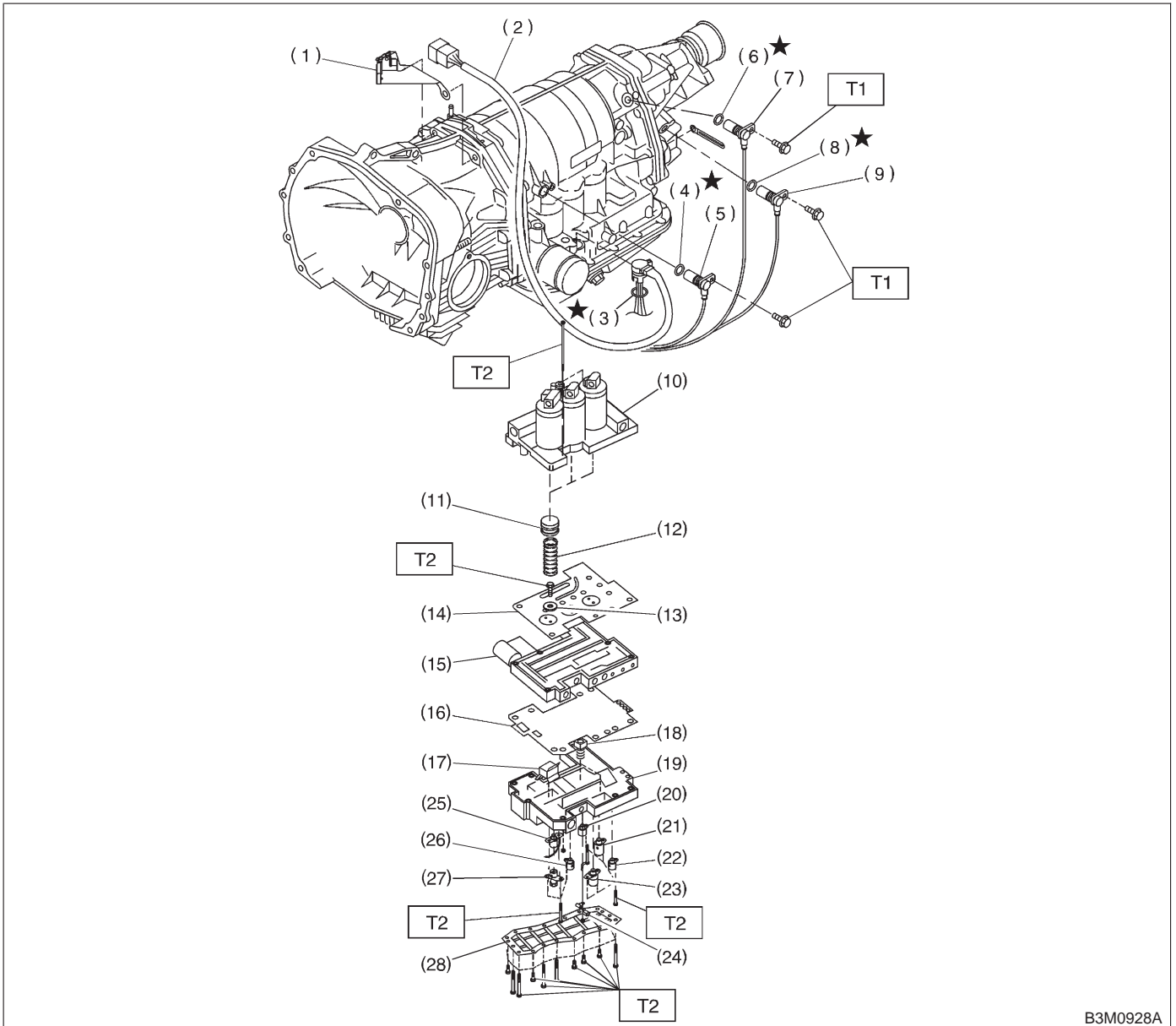

B3M0928A

- | | | |
|---|----------------------------------|--------------------------------------|
| (1) Stay | (12) Accumulator spring | (24) ATF temperature sensor |
| (2) Transmission harness | (13) Side plate | (25) Duty solenoid A (Line pressure) |
| (3) O-ring | (14) Separate plate | (26) Low clutch timing solenoid |
| (4) O-ring | (15) Middle valve body | (27) Duty solenoid B (Lock-up) |
| (5) Torque converter turbine speed sensor | (16) Separate plate | (28) Oil strainer |
| (6) O-ring | (17) Fluid filter | |
| (7) Vehicle speed sensor 2 (Front) | (18) Fluid filter | |
| (8) O-ring | (19) Lower valve body | |
| (9) Vehicle speed sensor 1 (Rear) | (20) Shift solenoid 2 | |
| (10) Upper valve body | (21) Shift solenoid 1 | |
| (11) Accumulator piston | (22) 2-4 brake timing solenoid | |
| | (23) Duty solenoid D (2-4 brake) | |

Tightening torque: N·m (kg·m, ft·lb)

T1: 7±1 (0.7±0.1, 5.1±0.7)

T2: 8±1 (0.8±0.1, 5.8±0.7)

5. High Clutch and Reverse Clutch

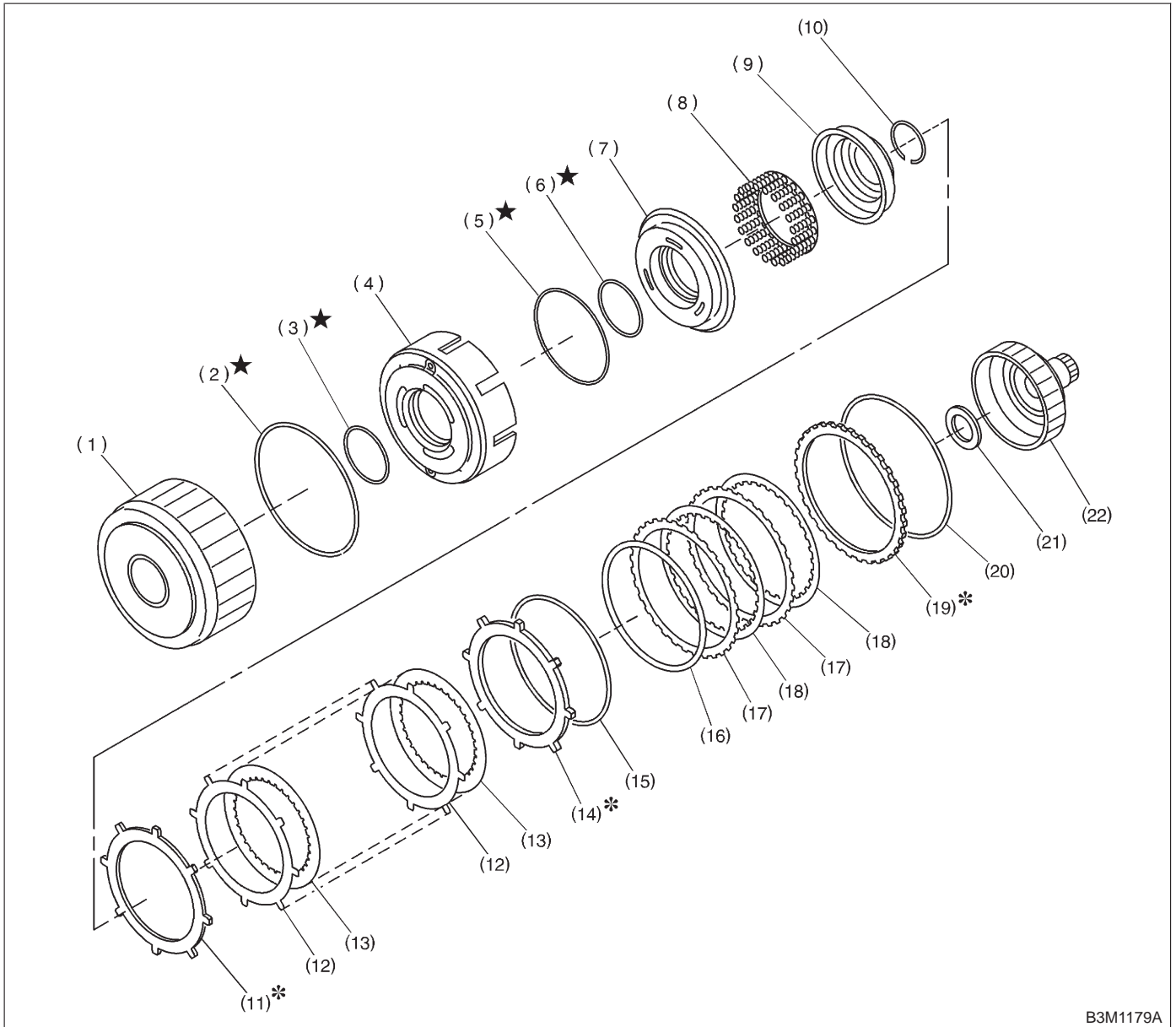

B3M1179A

- | | | |
|---------------------------|-----------------------------|----------------------------|
| (1) High clutch drum | (9) Cover | (17) Driven plate |
| (2) Lip seal | (10) Snap ring | (18) Drive plate |
| (3) Lathe cut seal ring | (11) Driven plate (Thicker) | (19) Retaining plate |
| (4) Reverse clutch piston | (12) Driven plate (Thinner) | (20) Snap ring |
| (5) Lathe cut seal ring | (13) Drive plate | (21) Thrust needle bearing |
| (6) Lathe cut seal ring | (14) Retaining plate | (22) High clutch hub |
| (7) High clutch piston | (15) Snap ring | |
| (8) Spring retainer | (16) Dish plate | |

6. Planetary Gear and 2-4 Brake

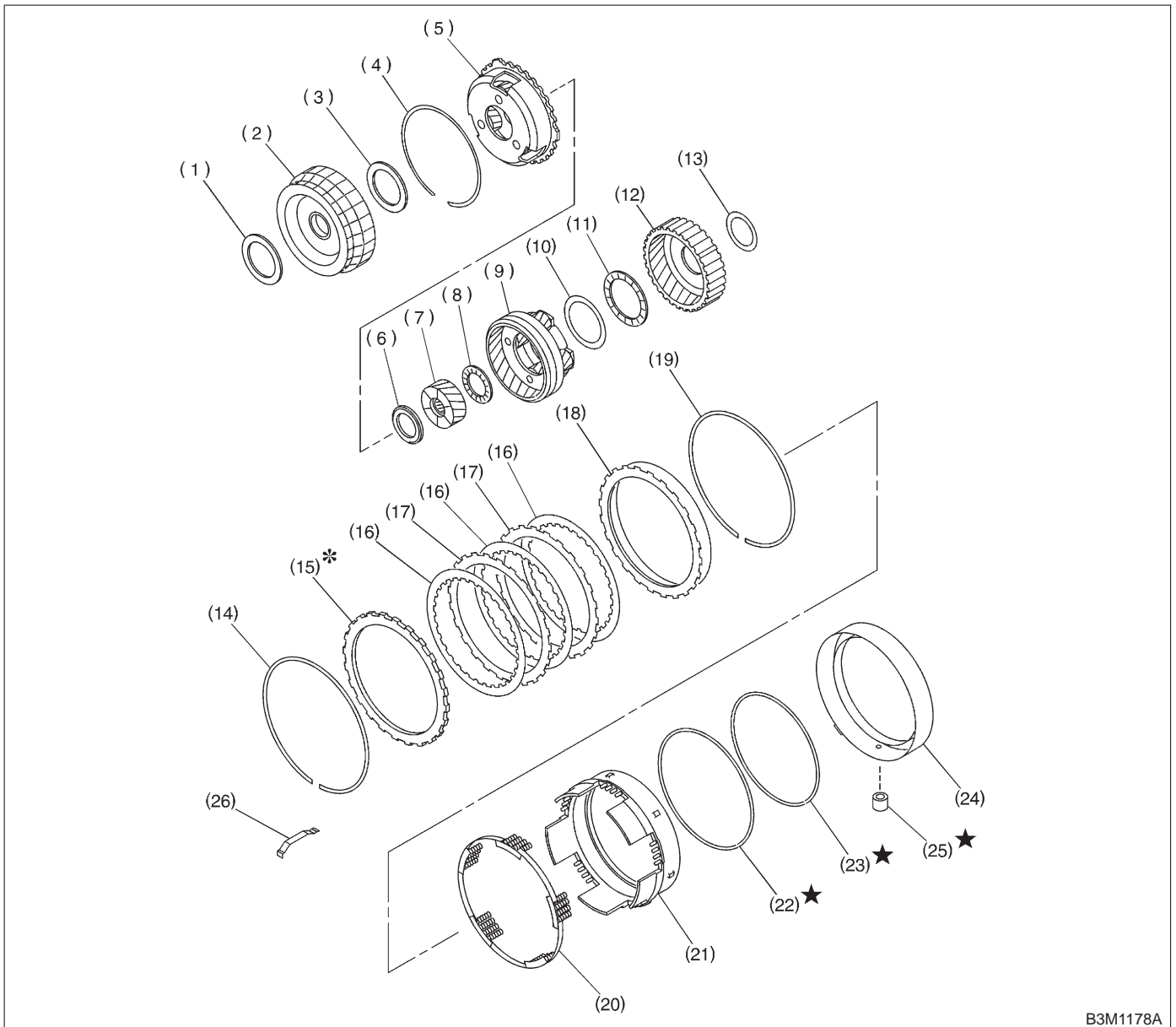

B3M1178A

- | | | |
|-----------------------------|----------------------------|--------------------------------|
| (1) Thrust needle bearing | (10) Washer | (19) Snap ring |
| (2) Front sun gear | (11) Thrust needle bearing | (20) Spring retainer |
| (3) Thrust needle bearing | (12) Rear internal gear | (21) 2-4 brake piston |
| (4) Snap ring | (13) Washer | (22) Lathe cut seal ring |
| (5) Front planetary carrier | (14) Snap ring | (23) Lathe cut seal ring |
| (6) Thrust needle bearing | (15) Retaining plate | (24) 2-4 brake piston retainer |
| (7) Rear sun gear | (16) Drive plate | (25) 2-4 brake seal |
| (8) Thrust needle bearing | (17) Driven plate | (26) Leaf spring |
| (9) Rear planetary carrier | (18) Pressure rear plate | |

7. Low Clutch and Low & Reverse Brake

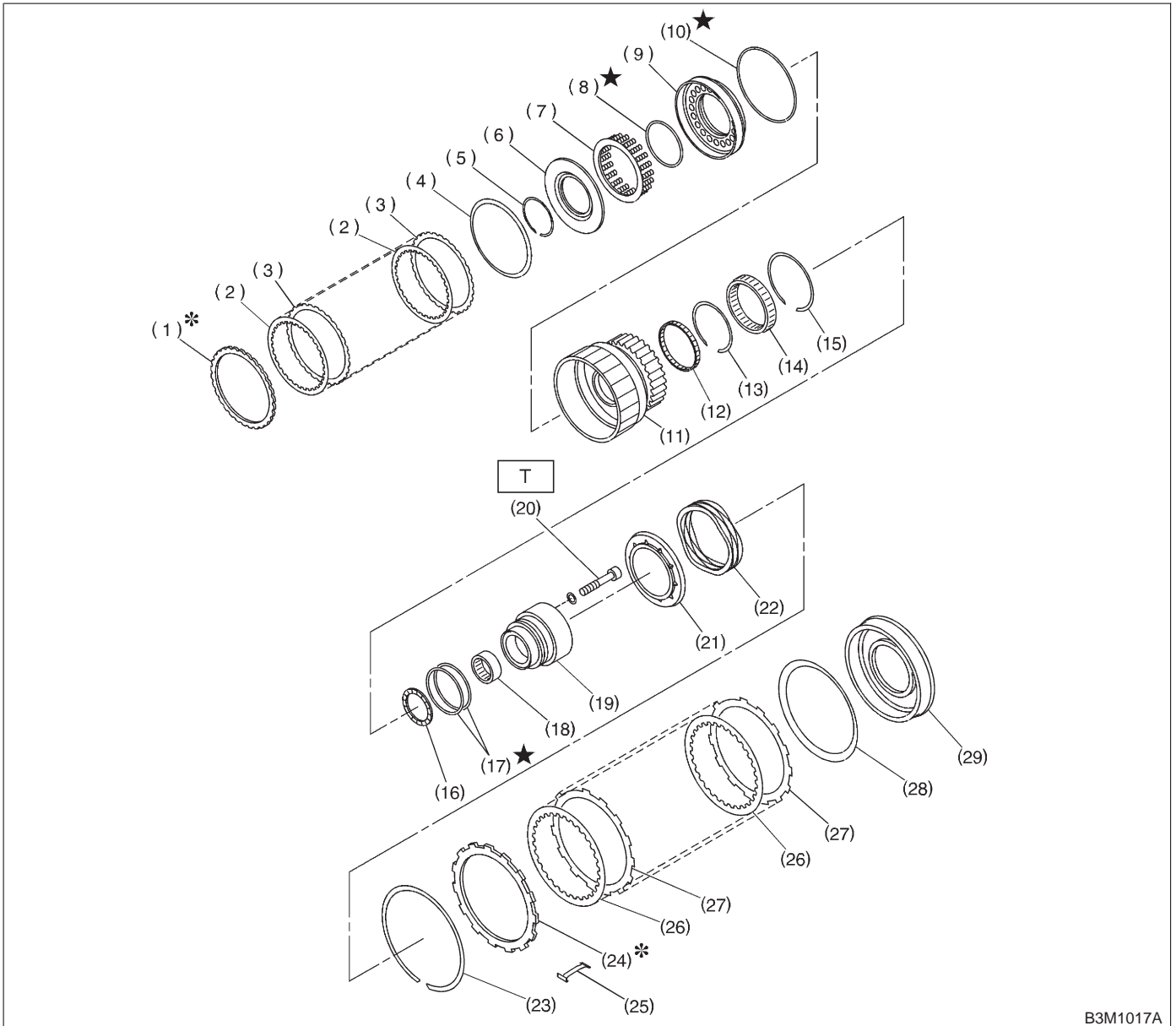

B3M1017A

- | | | |
|--------------------------|--------------------------------|-----------------------------------|
| (1) Retaining plate | (12) Needle bearing | (23) Snap ring |
| (2) Drive plate | (13) Snap ring | (24) Retaining plate |
| (3) Driven plate | (14) One-way clutch | (25) Leaf spring |
| (4) Dish plate | (15) Snap ring | (26) Drive plate |
| (5) Snap ring | (16) Thrust needle bearing | (27) Driven plate |
| (6) Cover | (17) Seal ring | (28) Dish plate |
| (7) Spring retainer | (18) Needle bearing | (29) Low and reverse brake piston |
| (8) Lathe cut seal ring | (19) One-way clutch inner race | |
| (9) Low piston | (20) Socket bolt | |
| (10) Lathe cut seal ring | (21) Spring retainer | |
| (11) Low clutch drum | (22) Return spring | |

Tightening torque: N-m (kg-m, ft-lb)
T: 25±2 (2.5±0.2, 18.1±1.4)

8. Reduction Gear

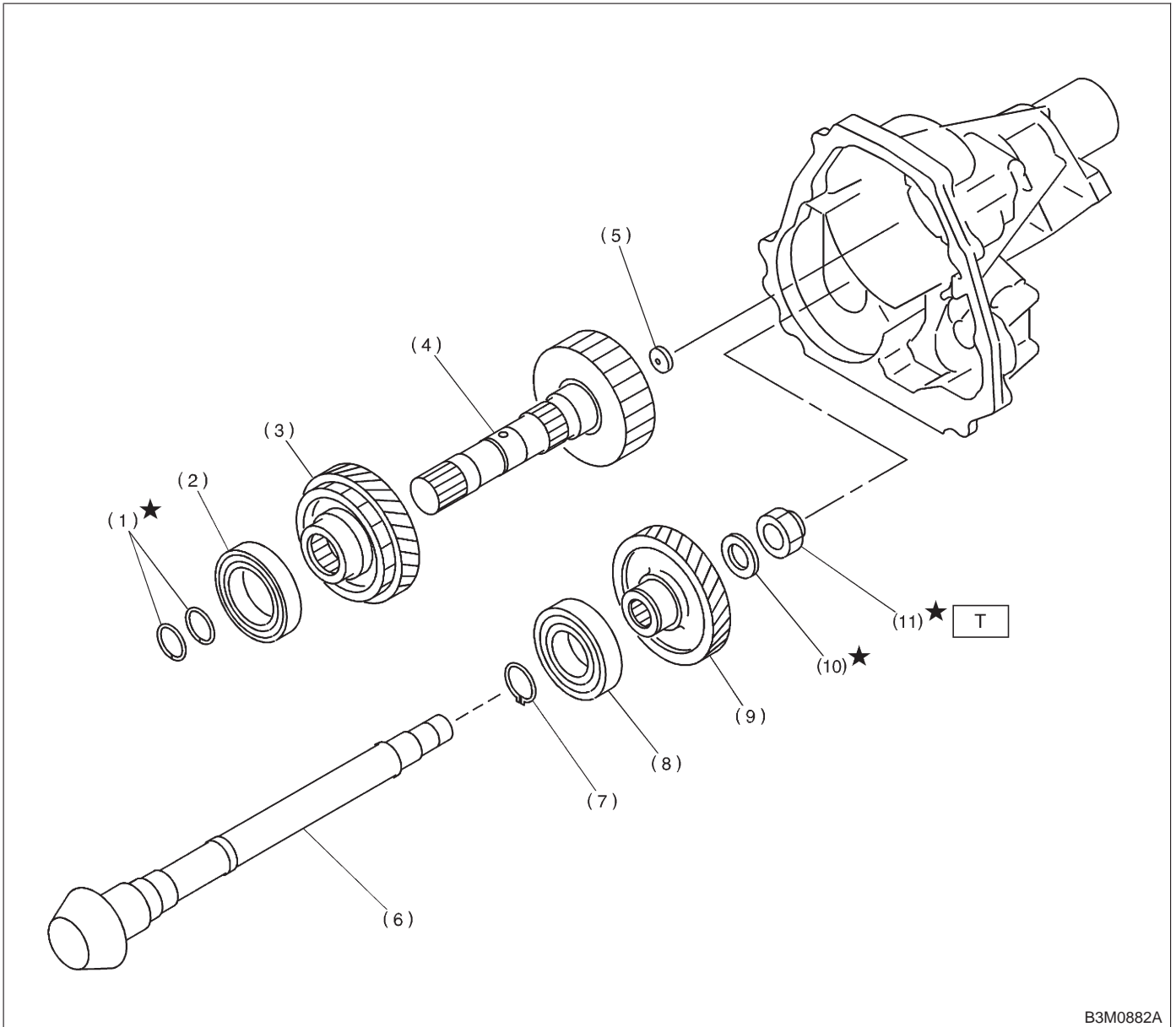

- (1) Seal ring
- (2) Ball bearing
- (3) Reduction drive gear
- (4) Reduction drive shaft
- (5) Plug

- (6) Drive pinion shaft
- (7) Snap ring
- (8) Ball bearing
- (9) Reduction driven gear
- (10) Washer

- (11) Lock nut

Tightening torque: N-m (kg-m, ft-lb)
T: 100±5 (10.2±0.5, 73.8±3.6)

9. Differential Case

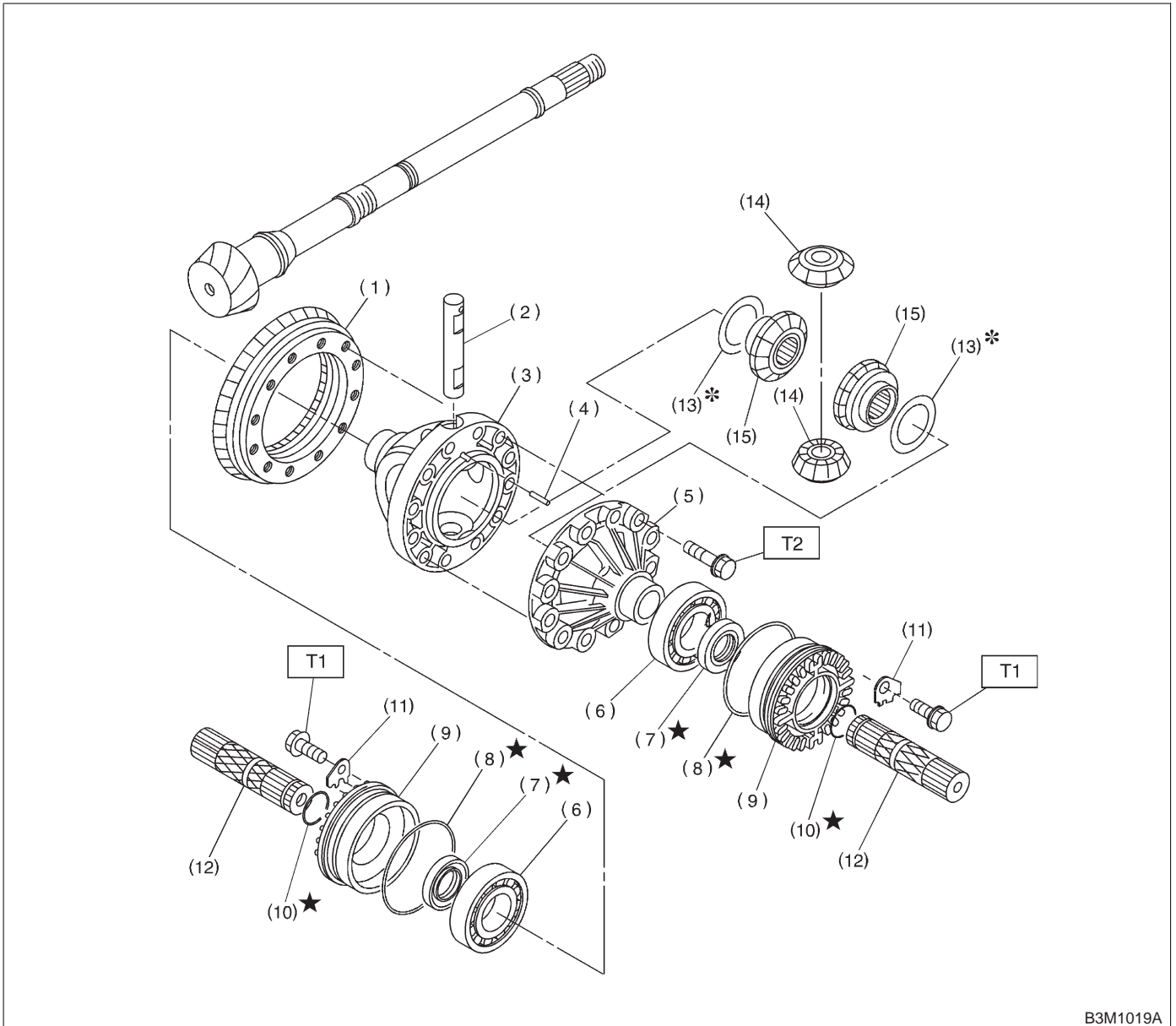

B3M1019A

- (1) Crown gear
- (2) Pinion shaft
- (3) Differential case (RH)
- (4) Straight pin
- (5) Differential case (LH)
- (6) Taper roller bearing
- (7) Oil seal
- (8) O-ring
- (9) Differential side retainer
- (10) Circlip
- (11) Lock plate
- (12) Axle shaft

- (13) Washer
- (14) Differential bevel pinion
- (15) Differential bevel gear

Tightening torque: N-m (kg-m, ft-lb)

T1: 25±2 (2.5±0.2, 18.1±1.4)

T2: 62±5 (6.3±0.5, 45.6±3.6)

10. Transfer and Extension

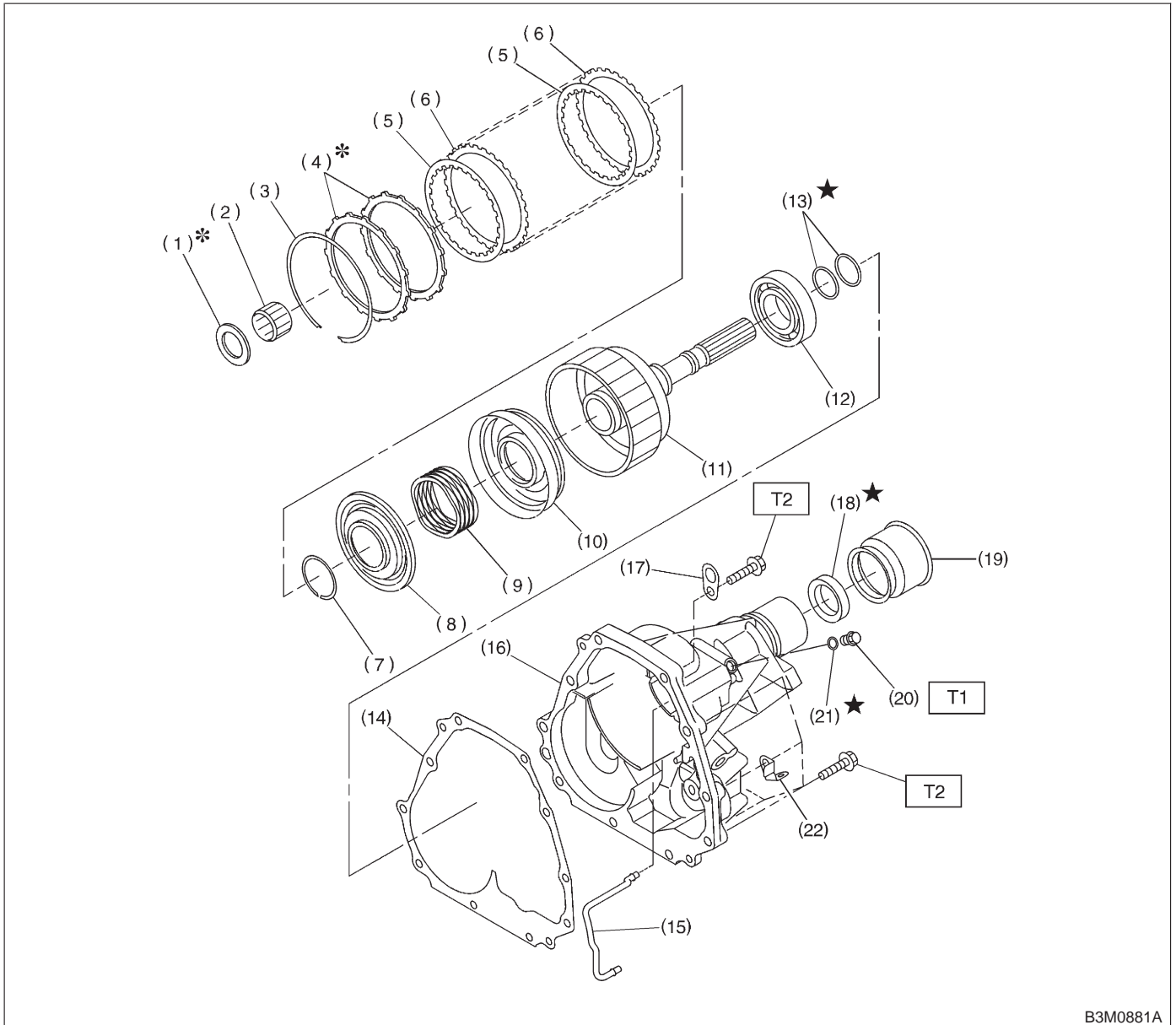

B3M0881A

- (1) Thrust needle bearing
- (2) Needle bearing
- (3) Snap ring
- (4) Pressure plate
- (5) Drive plate
- (6) Driven plate
- (7) Snap ring
- (8) Transfer piston seal
- (9) Return spring

- (10) Transfer clutch piston
- (11) Rear drive shaft
- (12) Ball bearing
- (13) Seal ring
- (14) Gasket
- (15) Transfer clutch pipe
- (16) Extension case
- (17) Transmission hanger
- (18) Oil seal

- (19) Dust seal
- (20) Test plug
- (21) O-ring
- (22) Clip

Tightening torque: N-m (kg-m, ft-lb)

T1: 13±1 (1.3±0.1, 9.4±0.7)

T2: 25±2 (2.5±0.2, 18.1±1.4)

1. General

A: PRECAUTION

When disassembling or assembling the automatic transmission, observe the following instructions.

1) Workshop

Provide a place that is clean and free from dust. Principally the conventional workshop is suitable except for a dusty place. In a workshop where grinding work, etc. which produces fine particles is done, make independent place divided by the vinyl curtain or the equivalent.

2) Work table

The size of 1 x 1.5 m (40 x 60 in) is large enough to work, and it is more desirable that its surface be covered with flat plate like iron plate which is not rusted too much.

3) Cleaning of exterior

(1) Clean the exterior surface of transmission with steam and/or kerosene prior to disassembly, however it should be noted that vinyl tape be placed on the air breather or oil level gauge to prevent infiltration of the steam into the transmission and also the cleaning job be done away from the place of disassembly and assembly.

(2) Partial cleaning will do, depending on the extent of disassembly (such as when disassembly is limited to some certain parts).

4) Disassembly, assembly and cleaning

(1) Disassemble and assemble the transmission while inspecting the parts in accordance with the Diagnostics.

(2) During job, do not use gloves. Do not clean the parts with rags: Use chamois or nylon cloth.

(3) Pay special attention to the air to be used for cleaning. Get the moisture and the dust rid of the air as much as possible. Be careful not to scratch or dent any part while checking for proper operation with an air gun.

(4) Complete the job from cleaning to completion of assembly as continuously and speedily as possible in order to avoid occurrence of secondary troubles caused by dust. When stopping the job unavoidably cover the parts with clean chamois or nylon cloth to keep them away from any dust.

(5) Use kerosene, white gasoline or the equivalent as washing fluid. Use always new fluid for cleaning the automatic transmission parts and never reuse. The used fluid is usable in disassemble and assemble work of engine and manual transmission.

(6) Although the cleaning should be done by dipping into the washing fluid or blowing of the pressurized washing fluid, the dipping is more desirable. (Do not rub with a brush.) Assemble

the parts immediately after the cleaning without exposure to the air for a while. Besides in case of washing rubber parts, perform the job quickly not to dip them into the washing fluid for long time.

(7) Apply the automatic transmission fluid (ATF) onto the parts immediately prior to assembly, and the specified tightening torque should be observed carefully.

(8) Use vaseline if it is necessary to hold parts in the position when assembling.

(9) Drain ATF and differential gear oil into a saucer so that the conditions of fluid and oil can be inspected.

(10) Do not support axle drive shaft, stator shaft, input shaft or various pipes when moving transmission from one place to another.

(11) Always discard old oil seals and O-ring, and install new ones.

(12) Always discard old oil seals and O-ring, and install new ones.

(13) Be sure to replace parts which are damaged, worn, scratched, discolored, etc.

B: INSPECTION

1. ATF LEVEL

1) Raise ATF temperature to 60 to 80°C (140 to 176°F) from 40 to 60°C (104 to 140°F) (when cold) by driving a distance of 5 to 10 km (3 to 6 miles).

NOTE:

The level of ATF varies with fluid temperature. Pay attention to the fluid temperature when checking oil level.

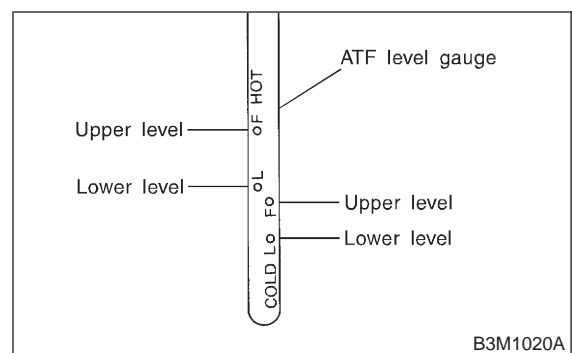

2) Make sure the vehicle is level. After selecting all positions (P, R, N, D, 3, 2, 1), set the selector lever in "P" range. Measure fluid level with the engine idling.

NOTE:

After running, idle the engine for one or two minutes before measurement.

3) If the fluid level is below the center between upper and lower marks, add the recommended ATF until the fluid level is found within the specified

1. General

range (above the center between upper and lower marks). When the transmission is hot, the level should be above the center of upper and lower marks, and when it is cold, the level should be found below the center of these two marks.

CAUTION:

- Use care not to exceed the upper limit level.
- ATF level varies with temperature. Remember that the addition of fluid to the upper limit mark when the transmission is cold will result in the overfilling of fluid.

4) Fluid temperature rising speed

- By idling the engine

Time for temperature rise to 60°C (140°F) with atmospheric temperature of 0°C (32°F): More than 25 minutes

<Reference>

Time for temperature rise to 30°C (86°F) with atmospheric temperature of 0°C (32°F): Approx. 8 minutes

- By running the vehicle

Time for temperature rise to 60°C (140°F) with atmospheric temperature of 0°C (32°F): More than 10 minutes

5) Method for checking fluid level upon delivery or at periodic inspection

Check fluid level after a warm-up run of approx. 10 minutes. During the warm-up period, the automatic transmission functions can also be checked.

2. DIFFERENTIAL GEAR OIL LEVEL

1) Ensure the vehicle is in safe condition.

NOTE:

Do not check the oil level nor add oil to the case with the front end of the vehicle jacked-up; this will result in an incorrect reading of the oil level.

2) Check whether the oil level is between the upper (F) and lower (L) marks. If it is below the lower limit mark, add oil until the level reaches the upper mark.

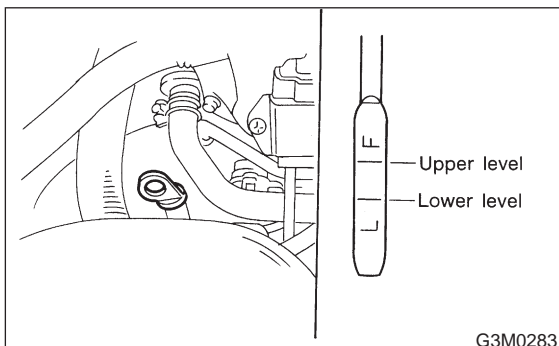

G3M0283

3. OIL LEAKAGE

It is difficult to accurately determine the precise position of a oil leak, since the surrounding area also becomes wet with oil. The places where oil seals and gaskets are used are as follows:

1) Jointing portion of the case

- Transmission case and oil pump housing jointing portion

- Torque converter clutch case and oil pump housing jointing portion

- Transmission case and extension case jointing portion

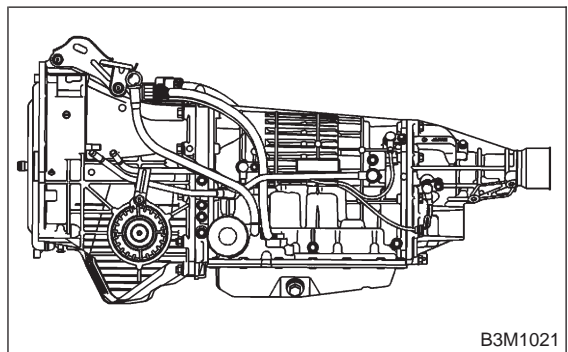

B3M1021

2) Torque converter clutch case

- Engine crankshaft oil seal
- Torque converter clutch impeller sleeve oil seal
- ATF cooler pipe connector
- Torque converter clutch
- Torque converter clutch case
- Axle shaft oil seal
- O-ring on the outside diameter of axle shaft oil seal holder
- O-ring on the differential oil gauge
- Differential oil drain plug
- Location of steel balls

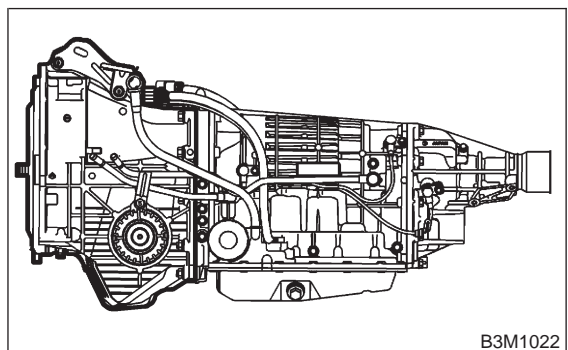

B3M1022

- 3) Oil pump housing
- Oil pump housing (Defective casting)
 - O-ring on the test plugs
 - Differential gear breather

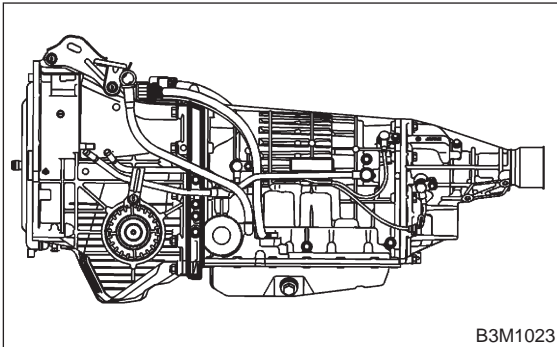

- 5) Extension case
- Extension case (Defective casting)
 - O-ring on the vehicle speed sensor 1 (Rear)
 - Rear drive shaft oil seal
 - O-ring on the test plugs

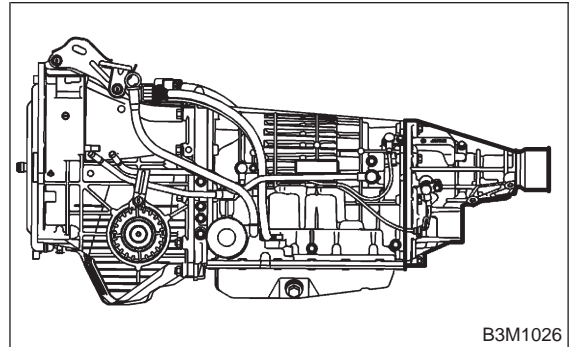

- 4) Automatic transmission case
- Transmission case (Defective casting)
 - Mating surface of oil pan
 - O-ring on the test plugs
 - Oil supply pipe connector
 - ATF cooler pipe connector and gasket
 - Oil pan drain plug
 - O-ring on the transmission harness holder
 - Oil pump plugs
 - ATF breather
 - Shift lever oil seal
 - O-ring on the vehicle speed sensor 2 (Front)
 - O-ring on the turbine revolution sensor
 - ATF filter oil seal

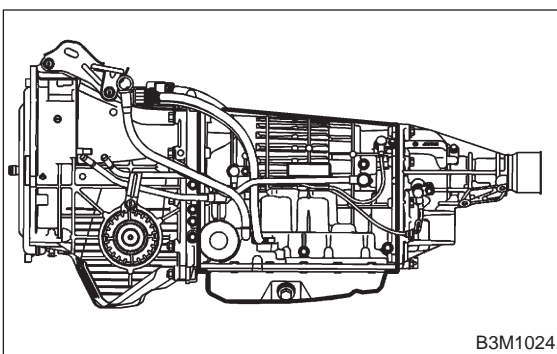

2. Inhibitor Switch

A: INSPECTION

When driving condition or starter motor operation is erroneous, first check the shift linkage for improper operation. If the shift linkage is functioning properly, check the inhibitor switch.

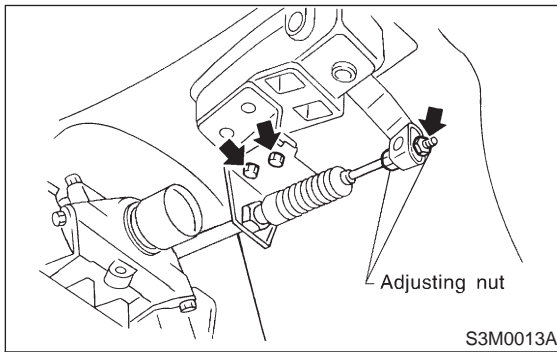

- 1) Disconnect cable end from select lever.
- 2) Disconnect inhibitor switch connector.
- 3) Check continuity in inhibitor switch circuits with select lever moved to each position.

CAUTION:

Also check that continuity in ignition circuit does not exist when select lever is in R, D, 3, 2 and 1 ranges.

NOTE:

If inhibitor switch is inoperative, check for poor contact of connector on transmission side.

	Position	Pin No.
Signal sent to TCM	P	4 — 3
	R	4 — 2
	N	4 — 1
	D	4 — 8
	3	4 — 7
	2	4 — 6
	1	4 — 5
Ignition circuit	P/N	12 — 11
Back-up light circuit	R	10 — 9

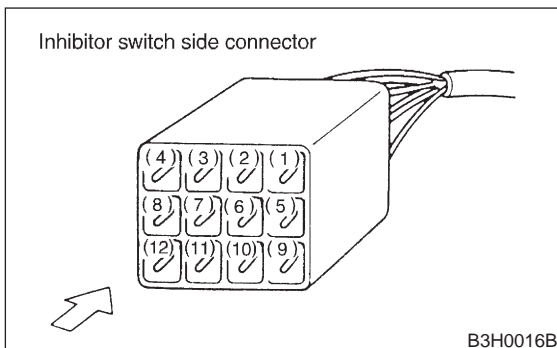

- 4) Check if there is continuity at equal points when the select lever is turned 1.5° in both directions from the N range.

If there is continuity in one direction and the continuity in the other or if there is continuity at unequal points, adjust the inhibitor switch.

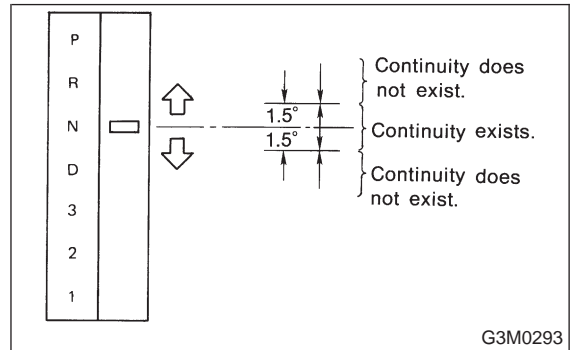

B: ADJUSTMENT

- 1) Loosen the three inhibitor switch securing bolts.
- 2) Shift the select lever to the N range.
- 3) Insert ST as vertical as possible into the holes in the inhibitor switch lever and switch body.
ST 499267300 STOPPER PIN

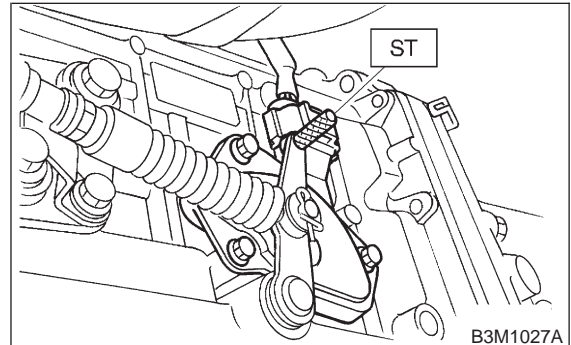

- 4) Tighten the three inhibitor switch bolts.

Tightening torque:

3.4±0.5 N-m (0.35±0.05 kg-m, 2.5±0.4 ft-lb)

- 5) Repeat the above checks. If the inhibitor switch is determined to be “faulty”, replace it.

C: REMOVAL

- 1) Move select lever to neutral position.
- 2) Remove air intake chamber and duct. (Except 2200 cc California spec. vehicles) <Ref. to 2-7 [W1A0].>
- 3) Remove air cleaner case and duct. (2200 cc California spec. vehicles) <Ref. to 2-7 [W1A0].> and <Ref. to 2-7 [W18A0].>
- 4) Disconnect inhibitor switch connector.

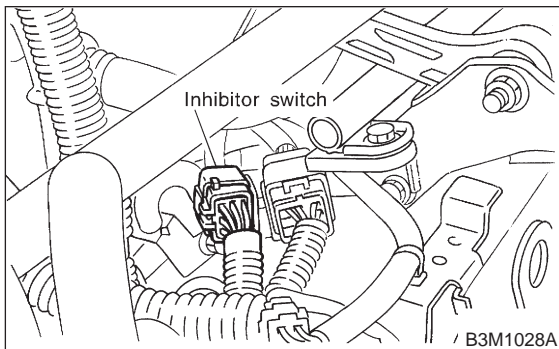

- 5) Remove front exhaust pipe. <Ref. to 2-9 [W1A0].>
- 6) Remove snap pin from range select lever.

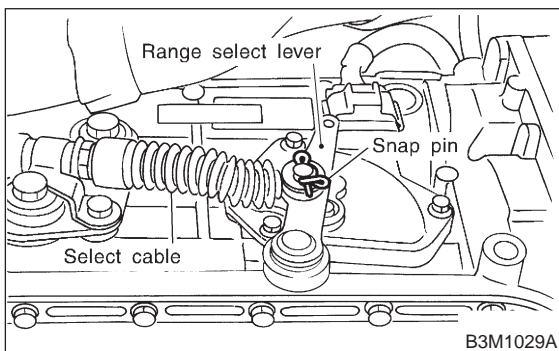

- 7) Remove plate assembly from transmission case.

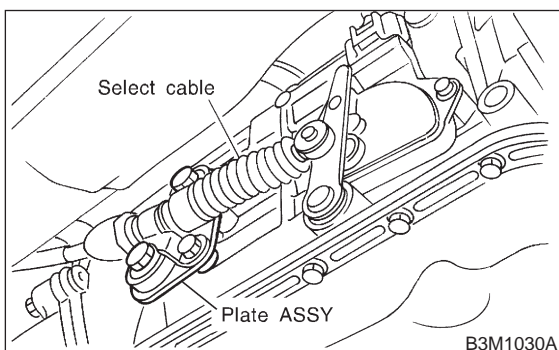

- 8) Remove bolts.

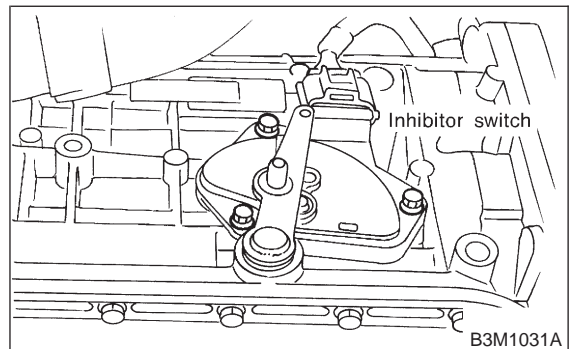

- 9) Move range select lever to parking position (left side).

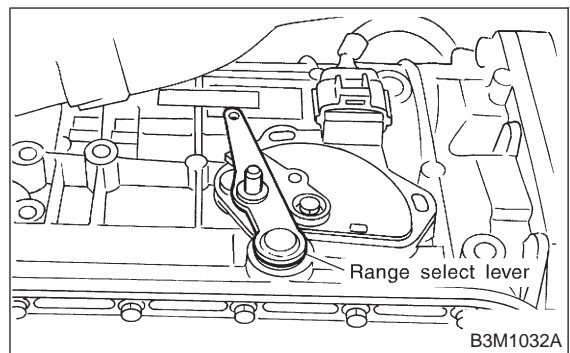

- 10) Remove inhibitor switch from transmission.

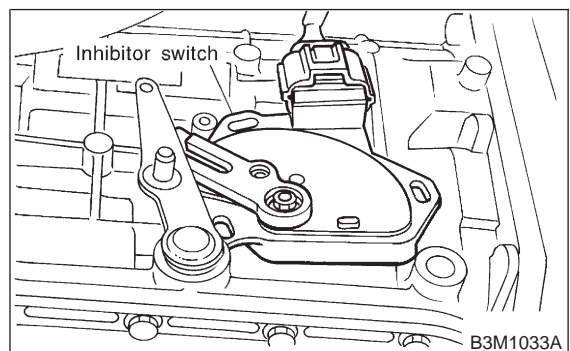

D: INSTALLATION

- 1) Install inhibitor switch to transmission case.

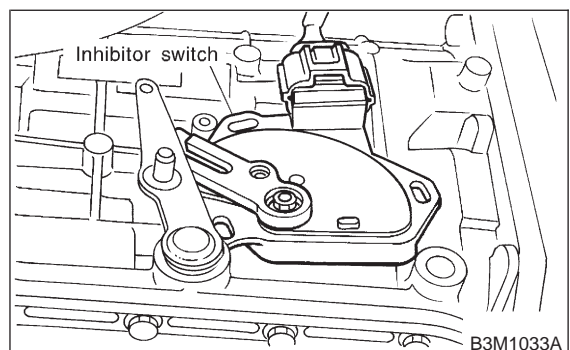

3-2 [W2D0]

2. Inhibitor Switch

SERVICE PROCEDURE

- 2) Move range select lever to neutral position.
- 3) Using ST, tighten bolts of inhibitor switch. <Ref. to 3-2 [W2B0].>

ST 499267300 STOPPER PIN

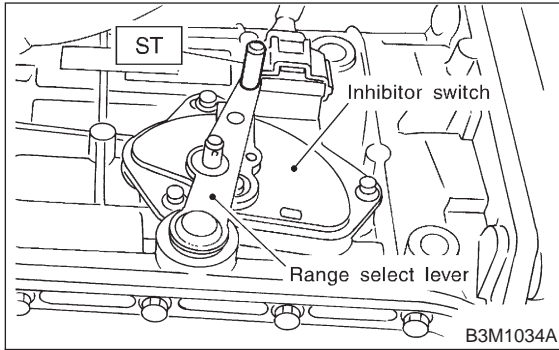

- 4) Install select cable to range select lever.
- 5) Install plate assembly to transmission.

Tightening torque:

T: 24.5±2.0 N·m (2.50±0.20 kg·m, 18.1±1.4 ft·lb)

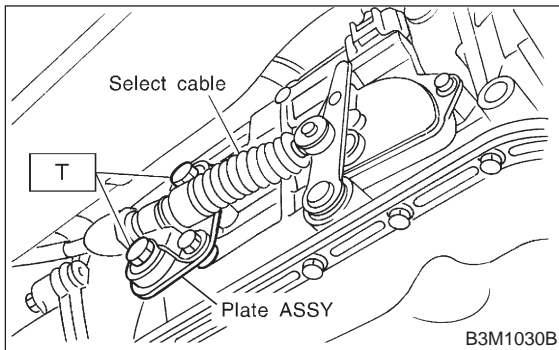

- 6) Install snap pin to range select lever.

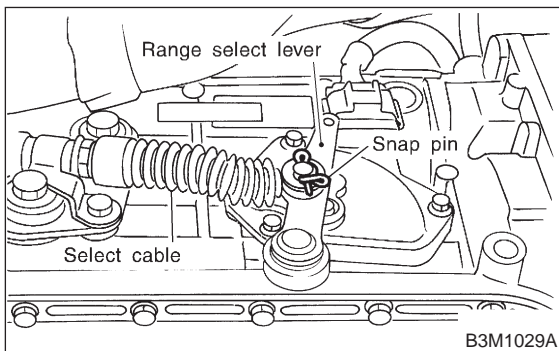

- 7) Install front exhaust pipe. <Ref. to 2-9 [W1B0].>
- 8) Connect inhibitor switch connector.

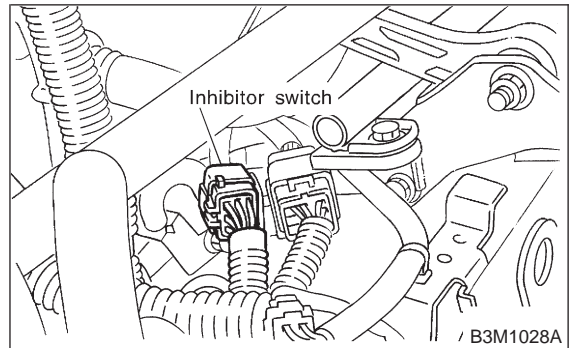

- 9) Install air intake chamber and duct. (Except 2200 cc California spec. vehicles) <Ref. to 2-7 [W1A0].>
- 10) Install air cleaner case and duct. (2200 cc California spec. vehicles) <Ref. to 2-7 [W1A0].> and <Ref. to 2-7 [W18A0].>

3. Sensor (in transmission)

A: INSPECTION

- 1) Remove air intake chamber and duct.
- 2) Disconnect transmission connector.

- 3) Check each sensor, solenoid and ground system for short circuits.

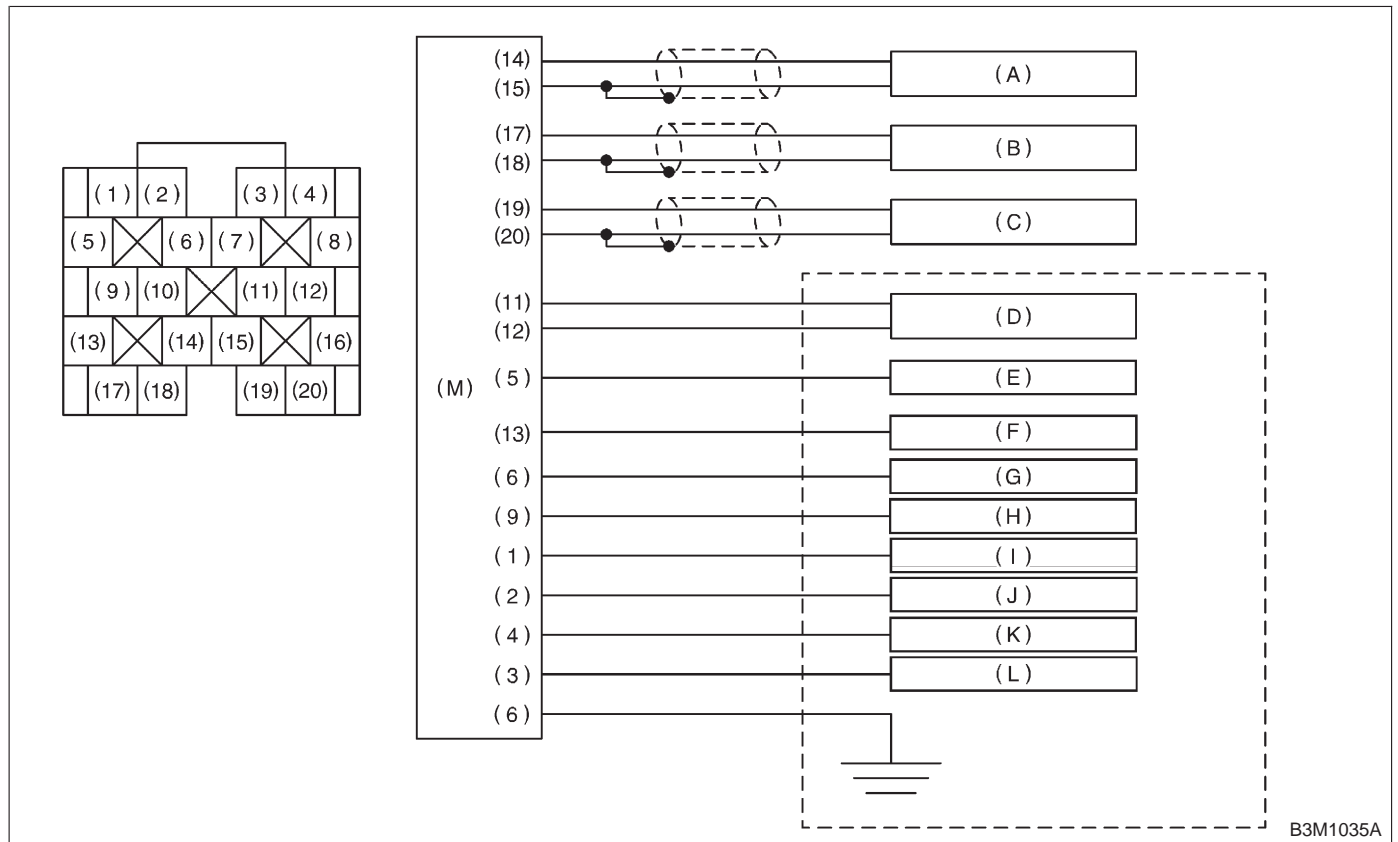
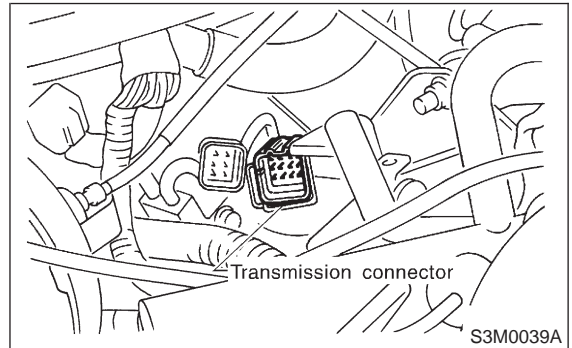
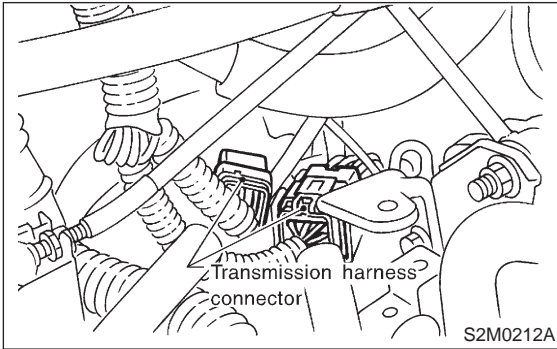

- (A) Torque converter turbine speed sensor
- (B) Vehicle speed sensor 2 (Front)
- (C) Vehicle speed sensor 1 (Rear)
- (D) ATF temperature sensor

- (E) Duty solenoid A (Line pressure)
- (F) Duty solenoid B (Lock-up)
- (G) Duty solenoid C (Transfer)
- (H) Duty solenoid D (2-4 brake)
- (I) Shift solenoid 1

- (J) Shift solenoid 2
- (K) 2-4 brake timing solenoid
- (L) Low clutch timing solenoid
- (M) Transmission connector

1. EVALUATION

NOTE:

If part is faulty, its resistance value will be different from the standard value indicated above.

Part name	Terminal	Resistance (Ω)
Vehicle speed sensor 1	17 — 18	450 — 650
Vehicle speed sensor 2	19 — 20	450 — 650
ATF temperature sensor	11 — 12	2,100 — 2,900/ 20°C (68°F) 275 — 375/ 80°C (176°F)
Torque converter turbine speed sensor	14 — 15	450 — 650
Shift solenoid 1	1 — 16	10 — 17
Shift solenoid 2	2 — 16	10 — 17
Duty solenoid A (Line pressure solenoid)	5 — 16	2.0 — 4.5
Duty solenoid B (Lock-up solenoid)	13 — 16	10 — 17
Duty solenoid D (2-4 brake solenoid)	9 — 16	2.0 — 4.5
Low clutch timing solenoid	3 — 16	10 — 16
2-4 brake timing solenoid	4 — 16	10 — 16
Duty solenoid C (Transfer clutch solenoid)	6 — 16	10 — 17

4. Shift Solenoid, Duty Solenoid and Valve

A: REMOVAL

- 1) Clean transmission exterior.
- 2) Drain ATF completely.

NOTE:

Tighten ATF drain plug after draining ATF.

Tightening torque:

25±2 N·m (2.5±0.2 kg·m, 18.1±1.4 ft·lb)

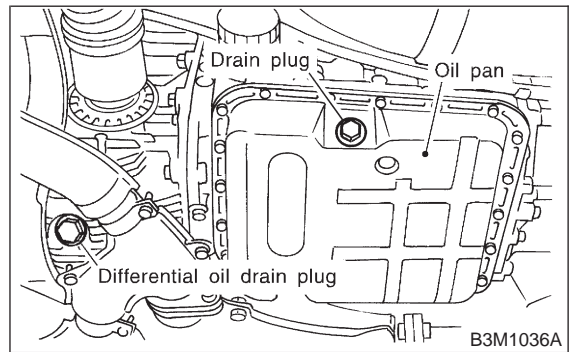

- 3) Remove oil pan.

NOTE:

Drain oil into a container.

- 4) Disconnect solenoid and sensor connectors. Remove connectors from clip and disconnect connectors at 8 places.

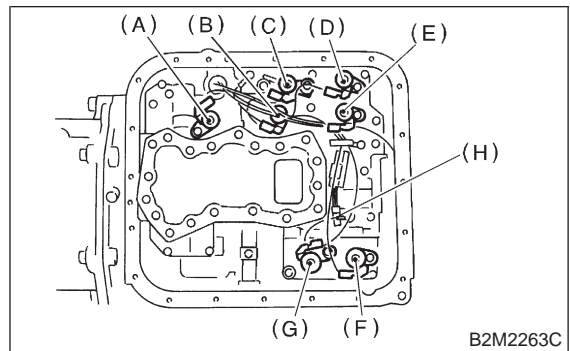

- (A) Lock-up duty solenoid (Blue)
- (B) Low clutch timing solenoid (Gray)
- (C) Line pressure duty solenoid (Red)
- (D) Shift solenoid 2 (Yellow)
- (E) Shift solenoid 1 (Green)
- (F) 2-4 brake timing solenoid (Black)
- (G) 2-4 brake duty solenoid (Red)
- (H) ATF temperature sensor

1. EVALUATION

NOTE:

If part is faulty, its resistance value will be different from the standard value indicated above.

Part name	Terminal	Resistance (Ω)
Vehicle speed sensor 1	17 — 18	450 — 650
Vehicle speed sensor 2	19 — 20	450 — 650
ATF temperature sensor	11 — 12	2,100 — 2,900/ 20°C (68°F) 275 — 375/ 80°C (176°F)
Torque converter turbine speed sensor	14 — 15	450 — 650
Shift solenoid 1	1 — 16	10 — 17
Shift solenoid 2	2 — 16	10 — 17
Duty solenoid A (Line pressure solenoid)	5 — 16	2.0 — 4.5
Duty solenoid B (Lock-up solenoid)	13 — 16	10 — 17
Duty solenoid D (2-4 brake solenoid)	9 — 16	2.0 — 4.5
Low clutch timing solenoid	3 — 16	10 — 16
2-4 brake timing solenoid	4 — 16	10 — 16
Duty solenoid C (Transfer clutch solenoid)	6 — 16	10 — 17

4. Shift Solenoid, Duty Solenoid and Valve

A: REMOVAL

- 1) Clean transmission exterior.
- 2) Drain ATF completely.

NOTE:

Tighten ATF drain plug after draining ATF.

Tightening torque:

25±2 N·m (2.5±0.2 kg·m, 18.1±1.4 ft·lb)

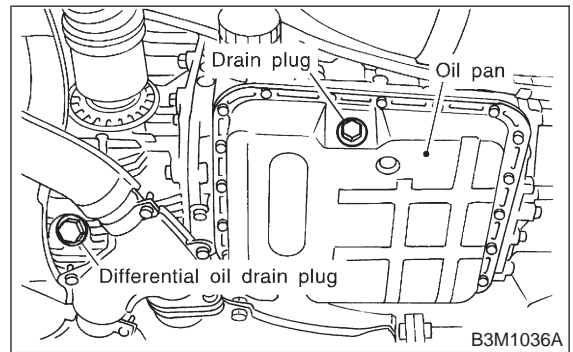

- 3) Remove oil pan.

NOTE:

Drain oil into a container.

- 4) Disconnect solenoid and sensor connectors. Remove connectors from clip and disconnect connectors at 8 places.

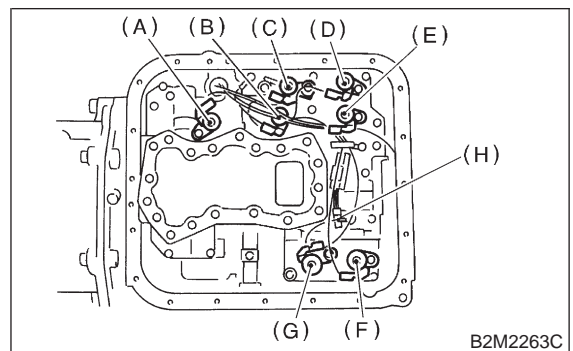

- (A) Lock-up duty solenoid (Blue)
- (B) Low clutch timing solenoid (Gray)
- (C) Line pressure duty solenoid (Red)
- (D) Shift solenoid 2 (Yellow)
- (E) Shift solenoid 1 (Green)
- (F) 2-4 brake timing solenoid (Black)
- (G) 2-4 brake duty solenoid (Red)
- (H) ATF temperature sensor

5) Remove control valve body.

CAUTION:

When removing control valve body, be careful not to interfere with transfer duty solenoid C wiring.

NOTE:

Be careful because oil flows from valve body.

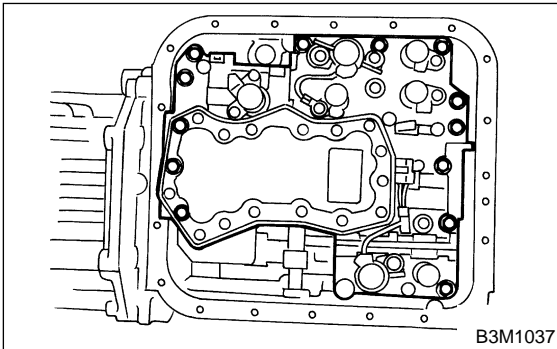

6) Remove oil strainer.

NOTE:

Be careful because oil flows from oil strainer.

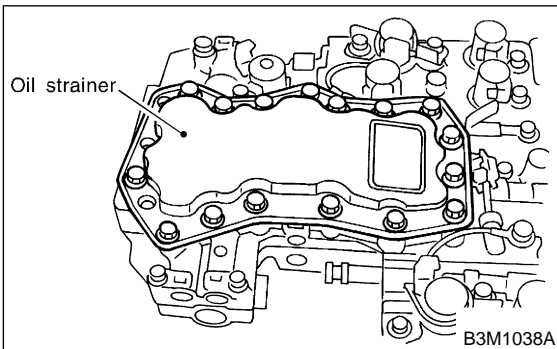

7) Remove solenoids and duty solenoids.

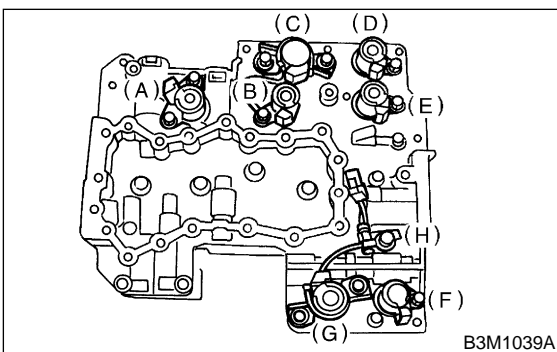

- (A) Lock-up duty solenoid (Blue)
- (B) Low clutch timing solenoid (Gray)
- (C) Line pressure duty solenoid (Red)
- (D) Shift solenoid 2 (Yellow)
- (E) Shift solenoid 1 (Green)
- (F) 2-4 brake timing solenoid (Black)
- (G) 2-4 brake duty solenoid (Red)
- (H) ATF temperature sensor

B: INSTALLATION

1) Install 7 solenoids and ATF temperature sensor.

Tightening torque:

T: 8±1 N·m (0.8±0.1 kg-m, 5.8±0.7 ft-lb)

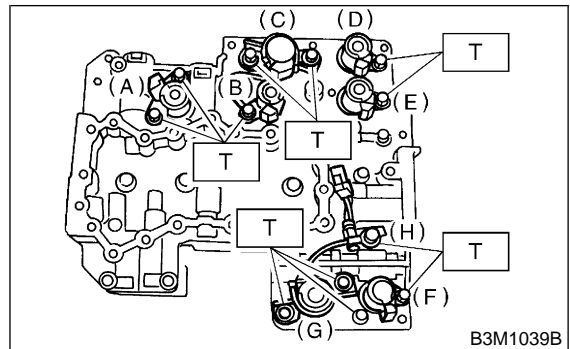

- (A) Lock-up duty solenoid (Blue)
- (B) Low clutch timing solenoid (Gray)
- (C) Line pressure duty solenoid (Red)
- (D) Shift solenoid 2 (Yellow)
- (E) Shift solenoid 1 (Green)
- (F) 2-4 brake timing solenoid (Black)
- (G) 2-4 brake duty solenoid (Red)
- (H) ATF temperature sensor

2) Install oil strainer.

Tightening torque:

8±1 N·m (0.8±0.1 kg-m, 5.8±0.7 ft-lb)

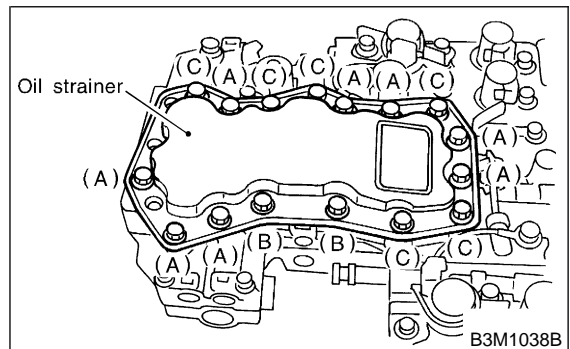

- (A) Short bolt
- (B) Middle bolt
- (C) Long bolt

3-2 [W4B0]

SERVICE PROCEDURE

4. Shift Solenoid, Duty Solenoid and Valve

3) Install valve body to transmission case.

CAUTION:

When installing control valve body, be careful not to interfere with transfer duty solenoid wiring (brown).

NOTE:

Align manual valve connections.

Tightening torque:

$8 \pm 1 \text{ N}\cdot\text{m}$ ($0.8 \pm 0.1 \text{ kg}\cdot\text{m}$, $5.8 \pm 0.7 \text{ ft}\cdot\text{lb}$)

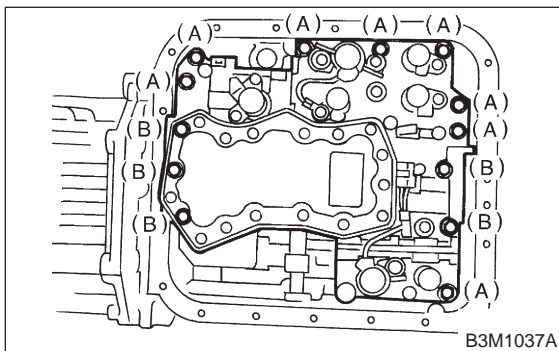

- (A) Short bolts
- (B) Long bolts

4) Connect harness connectors at 8 places. Connect connectors of same color, and secure connectors to valve body using clips.

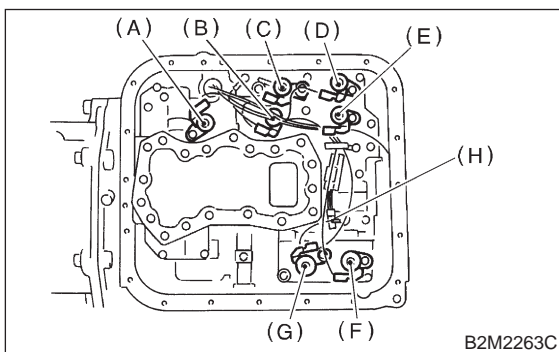

- (A) Lock-up duty solenoid (Blue)
- (B) Low clutch timing solenoid (Gray)
- (C) Line pressure duty solenoid (Red)
- (D) Shift solenoid 2 (Yellow)
- (E) Shift solenoid 1 (Green)
- (F) 2-4 brake timing solenoid (Black)
- (G) 2-4 brake duty solenoid (Red)
- (H) ATF temperature sensor

5) Apply proper amount of liquid gasket (THREE BOND Part No. 1217B) to the entire oil pan mating surface.

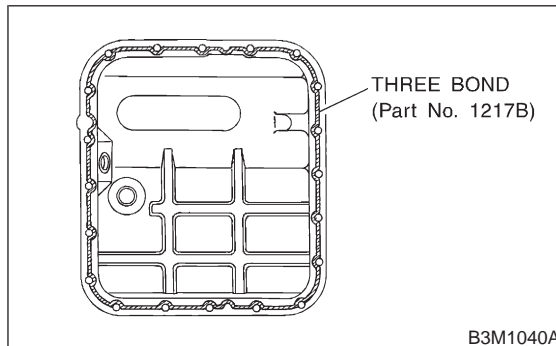

6) Install oil pan.

Tightening torque:

$4.9 \pm 0.5 \text{ N}\cdot\text{m}$ ($0.50 \pm 0.05 \text{ kg}\cdot\text{m}$, $3.6 \pm 0.4 \text{ ft}\cdot\text{lb}$)

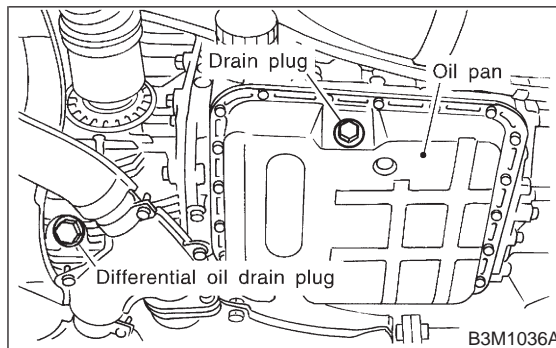

7) Add ATF and check level.

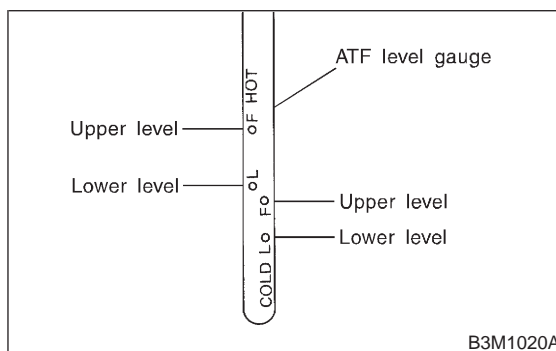

5. Duty Solenoid C and Transfer Valve Body

A: REMOVAL

1) Remove air intake duct and chamber. (Except 2200 cc California spec. vehicles)
 <Ref. to 2-7 [W1A0].>

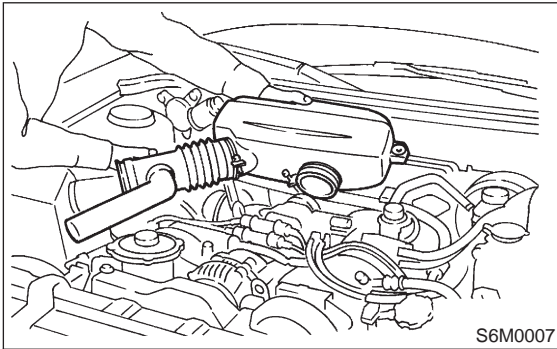

B6M0007

2) Remove air intake duct and cleaner case. (2200 cc California spec. vehicles)
 <Ref. to 2-7 [W1A0].> and <Ref. to 2-7 [W18A0].>

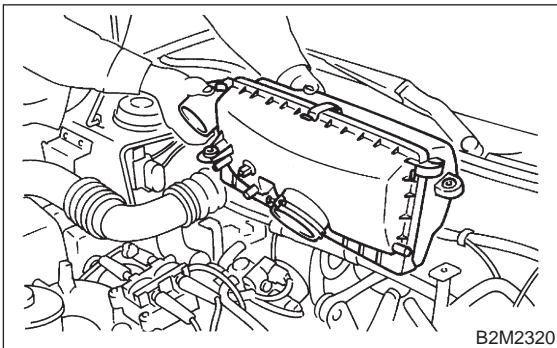

B2M2320

3) Remove pitching stopper.

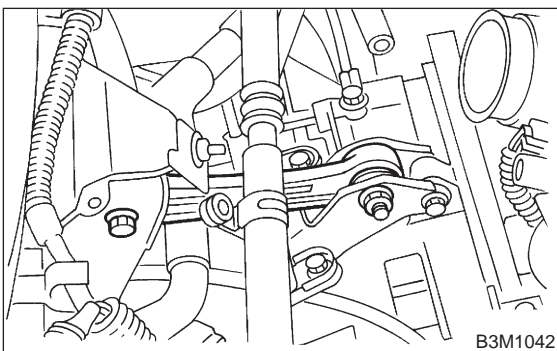

B3M1042

4) Raise vehicle and drain ATF.

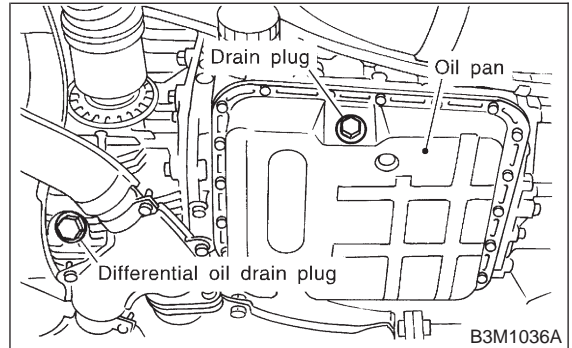

5) Remove front exhaust pipe and center exhaust pipe. Disconnect oxygen sensor connector, and remove exhaust pipe.
 <Ref. to 2-9 [W1A0].> and <Ref. to 2-9 [W2A0].>

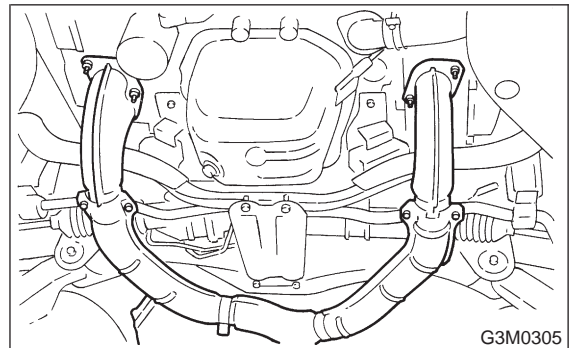

G3M0305

6) Remove propeller shaft.
 <Ref. to 3-4 [W1B0].>

NOTE:

Before removing propeller shaft, scribe matching marks on propeller shaft and rear differential coupling.

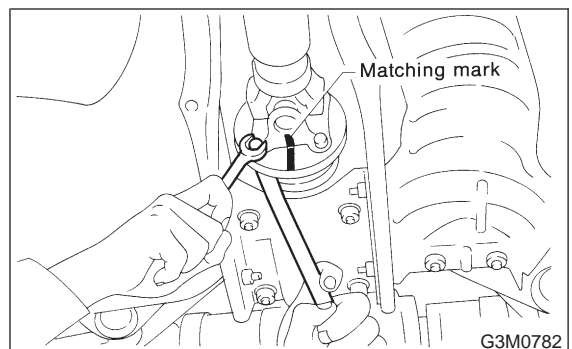

G3M0782

3-2 [W5B0]

SERVICE PROCEDURE

5. Duty Solenoid C and Transfer Valve Body

- 7) Remove rear crossmember.
(1) Support transmission using a transmission jack and raise slightly.
(2) Remove bolts and nuts as shown in Figure.

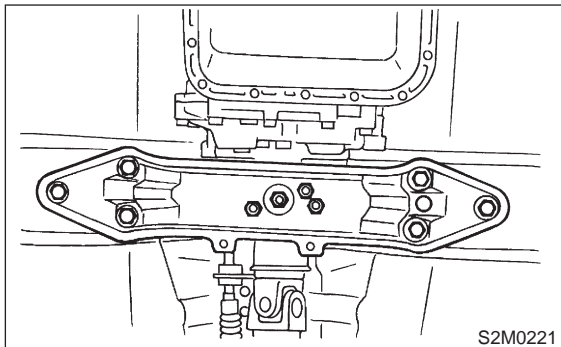

- 8) Remove vehicle speed sensor 1 (rear).

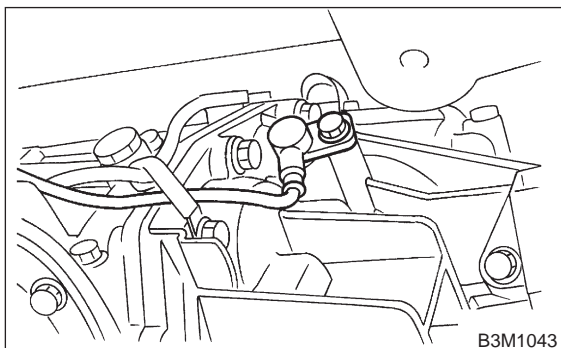

- 9) Remove extension and gasket.
(1) Remove select cable nut.

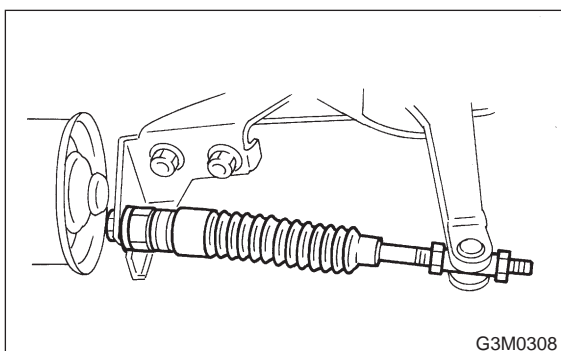

- (2) Move gear select cable so that extension bolts can be removed.
(3) Remove bolts.

- (4) Remove extension case.

NOTE:

Use a container to catch oil flowing from extension.

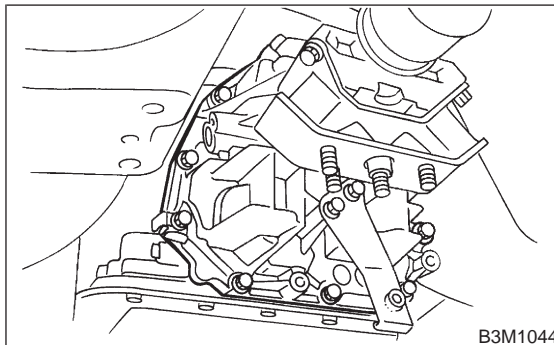

- 10) Disconnect duty solenoid C (transfer) connector.
11) Remove duty solenoid C (transfer) and transfer valve body.

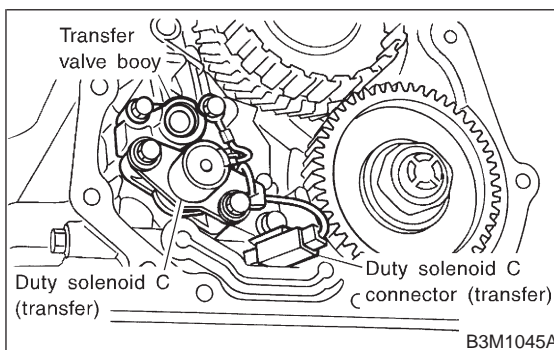

B: INSTALLATION

- 1) Install duty solenoid C and transfer valve body.
(1) Install duty solenoid C and transfer valve body.

Tightening torque:

T: 8 ± 1 N·m (0.8 ± 0.1 kg·m, 5.8 ± 0.7 ft·lb)

- (2) Connect duty solenoid C (transfer) connector.

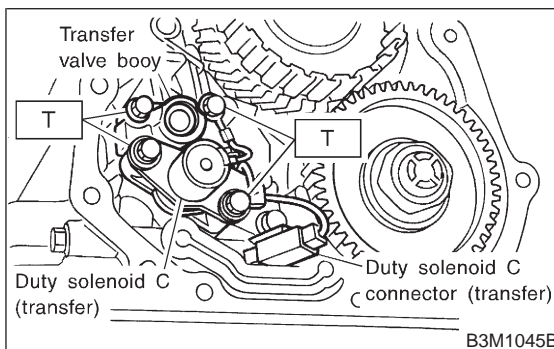

- 2) Install extension case to transmission case.
 (1) Tighten 11 bolts.

Tightening torque:

$25 \pm 2 \text{ N}\cdot\text{m}$ ($2.5 \pm 0.2 \text{ kg}\cdot\text{m}$, $18.1 \pm 1.4 \text{ ft}\cdot\text{lb}$)

- (2) Install select cable.

Tightening torque:

$14 \pm 4 \text{ N}\cdot\text{m}$ ($1.4 \pm 0.4 \text{ kg}\cdot\text{m}$, $10.1 \pm 2.9 \text{ ft}\cdot\text{lb}$)

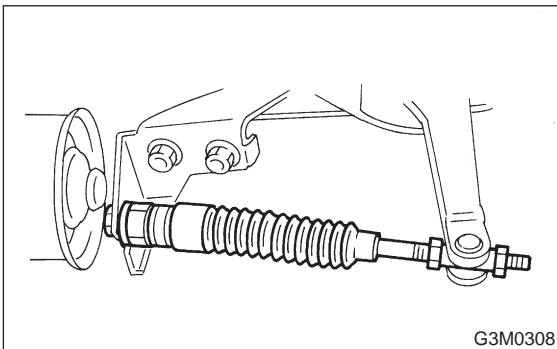

- 3) Install vehicle speed sensor 1 (rear).

Tightening torque:

$T: 7 \pm 1 \text{ N}\cdot\text{m}$ ($0.7 \pm 0.1 \text{ kg}\cdot\text{m}$, $5.1 \pm 0.7 \text{ ft}\cdot\text{lb}$)

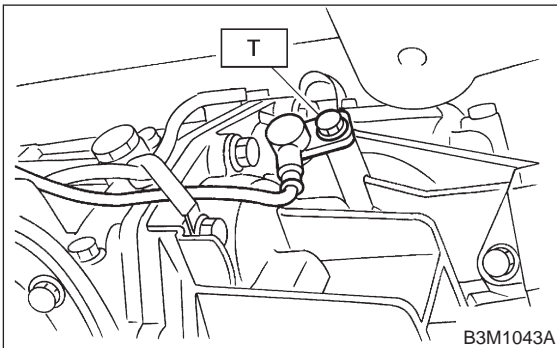

- 4) Install rear crossmember.

- (1) Tighten bolts.

Tightening torque:

$T1: 37 \pm 10 \text{ N}\cdot\text{m}$ ($3.8 \pm 1.0 \text{ kg}\cdot\text{m}$, $27 \pm 7 \text{ ft}\cdot\text{lb}$)

$T2: 69 \pm 15 \text{ N}\cdot\text{m}$ ($7.0 \pm 1.5 \text{ kg}\cdot\text{m}$, $51 \pm 11 \text{ ft}\cdot\text{lb}$)

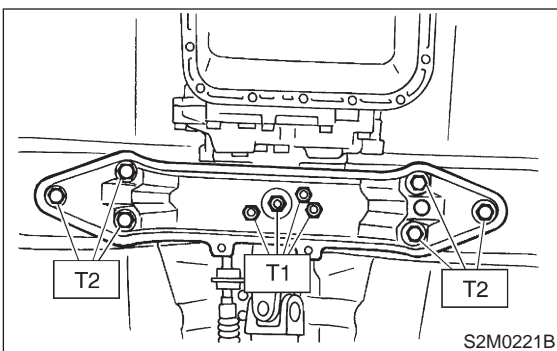

- (2) Lower and remove transmission jack.

- 5) Install propeller shaft.

<Ref. to 3-2 [W1E0].>

NOTE:

Align matching marks on propeller shaft and rear differential coupling.

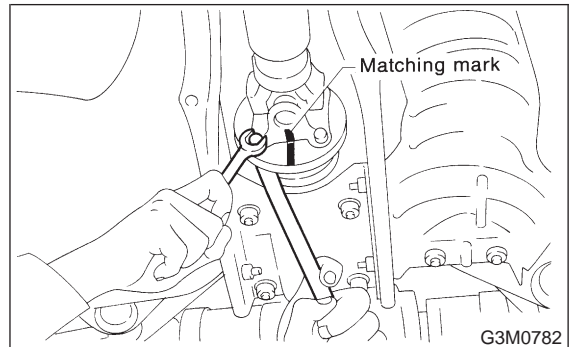

- 6) Install front exhaust pipe and center exhaust pipe.

<Ref. to 2-9 [W1A0].> and <Ref. to 2-9 [W2A0].>

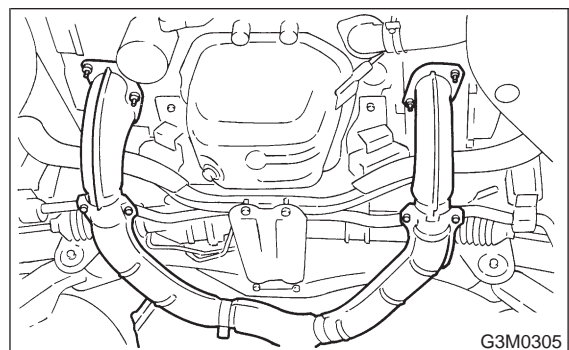

- 7) Lower and remove jack.

- 8) Connect the following parts:

- (1) Oxygen sensor connector
- (2) Transmission harness connector

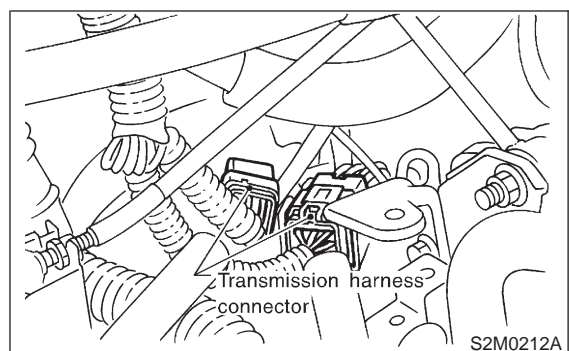

9) Install pitching stopper.

Tightening torque:

T1: 49 ± 5 N·m (5.0 ± 0.5 kg·m, 36.2 ± 3.6 ft·lb)

T2: 57 ± 10 N·m (5.8 ± 1.0 kg·m, 42 ± 7 ft·lb)

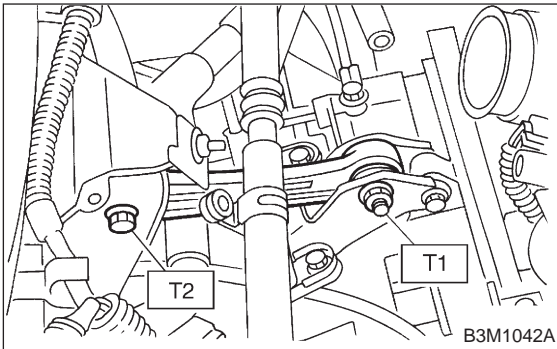

10) Replenish ATF and check oil level. Check for leaks.

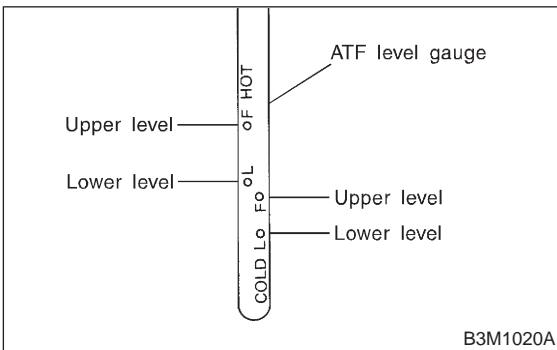

6. Road Test

A: INSPECTION

1. GENERAL PRECAUTION

Road tests should be conducted to properly diagnose the condition of the automatic transmission.

CAUTION:

When performing test, do not exceed posted speed limit.

2. SHIFT PATTERNS

Check "kick-down".

D range: 1st ← 2nd ← 3rd ← 4th

3 range: 1st ← 2nd ← 3rd ← 4th

2 range: 2nd ← 3rd ← 4th

1 range: 1st ← 2nd ← 3rd ← 4th

AWD model "D" range (Normal pattern)

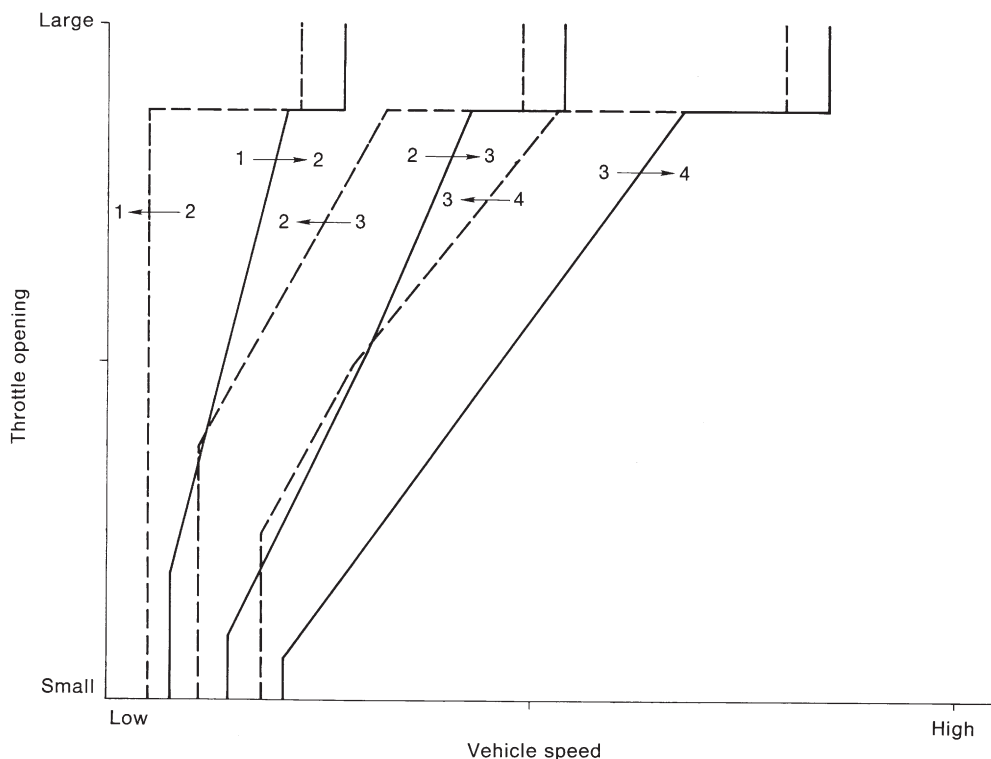

9) Install pitching stopper.

Tightening torque:

T1: 49 ± 5 N·m (5.0 ± 0.5 kg·m, 36.2 ± 3.6 ft·lb)

T2: 57 ± 10 N·m (5.8 ± 1.0 kg·m, 42 ± 7 ft·lb)

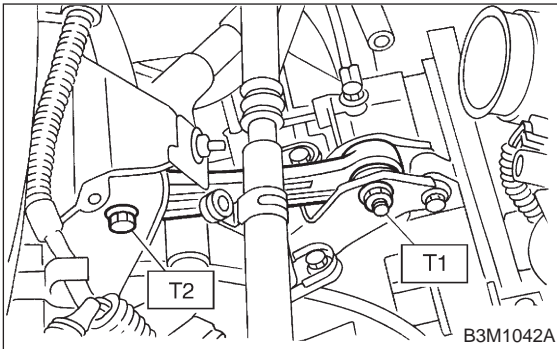

10) Replenish ATF and check oil level. Check for leaks.

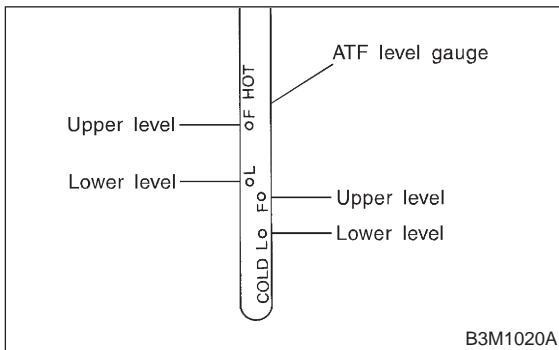

6. Road Test

A: INSPECTION

1. GENERAL PRECAUTION

Road tests should be conducted to properly diagnose the condition of the automatic transmission.

CAUTION:

When performing test, do not exceed posted speed limit.

2. SHIFT PATTERNS

Check "kick-down".

D range: 1st \leftarrow 2nd \leftarrow 3rd \leftarrow 4th

3 range: 1st \leftarrow 2nd \leftarrow 3rd \leftarrow 4th

2 range: 2nd \leftarrow 3rd \leftarrow 4th

1 range: 1st \leftarrow 2nd \leftarrow 3rd \leftarrow 4th

AWD model "D" range (Normal pattern)

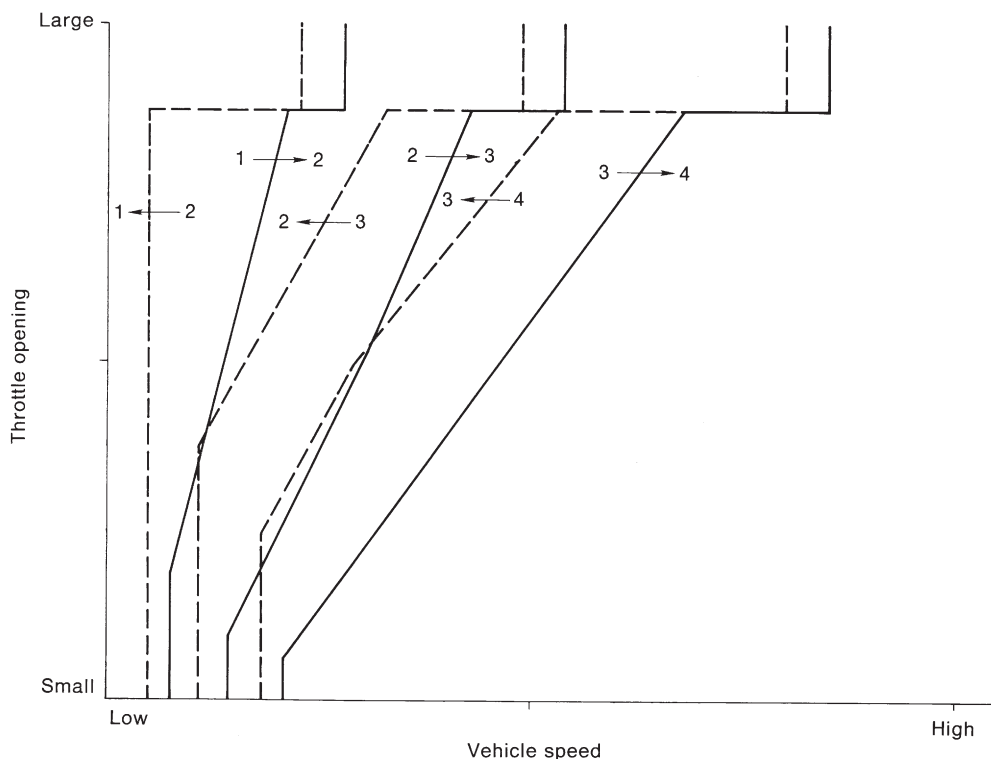

G3M0321

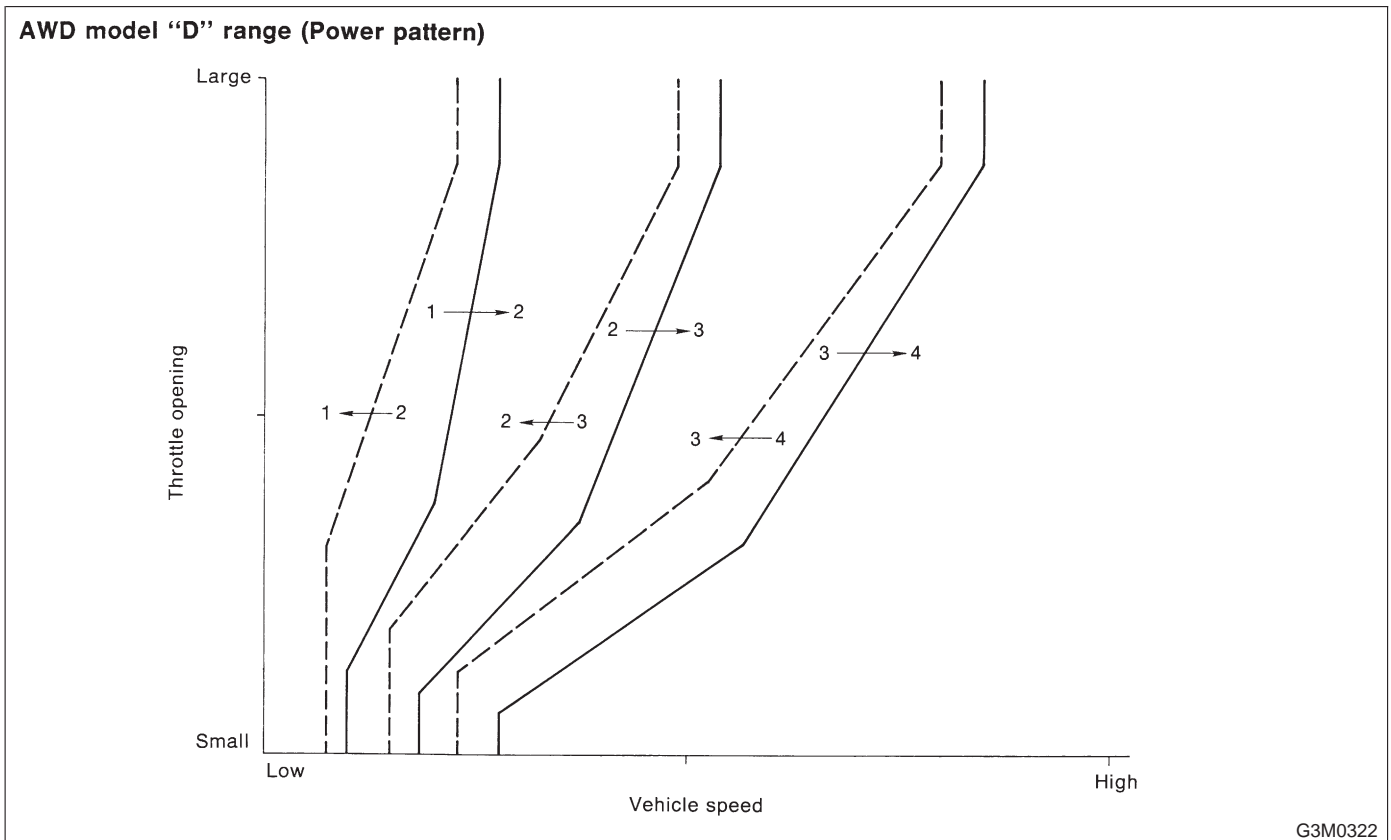

3. ENGINE BRAKE OPERATION

Engine brake operation:

- D range* → 4th gear
- 3 range* → 3rd gear
- 2 range* → 2nd gear
- 1 range* → 1st gear

4. AWD FUNCTION

If "tight-corner braking" occurs when the steering wheel is fully turned at low speed:

- 1) Determine the applicable trouble code and check the corresponding duty solenoid C (transfer) for improper operation.
- 2) If the solenoid is operating properly, check transfer clutch pressure.
- 3) If oil pressure is normal but "tight-corner braking" occurs:
Check the transfer control valve for sticking, and the transfer clutch facing for wear. <Ref. to 3-2 [W20B0].> and <Ref. to 3-2 [W21B0].>

7. Stall Test

A: MEASUREMENT

1. GENERAL INFORMATION

The stall test is of extreme importance in diagnosing the condition of the automatic transmission and the engine. It should be conducted to measure the engine stall speeds in R and 2 ranges.

Purposes of the stall test:

- 1) To check the operation of the automatic transmission clutch.
- 2) To check the operation of the torque converter clutch.
- 3) To check engine performance.

2. TEST METHODS

- 1) Preparations before test:
 - (1) Check that throttle valve opens fully.
 - (2) Check that engine oil level is correct.
 - (3) Check that coolant level is correct.
 - (4) Check that ATF level is correct.
 - (5) Check that differential gear oil level is correct.
 - (6) Increase ATF temperature to 50 to 80°C (122 to 176°F) by idling the engine for approximately 30 minutes (with select lever set to "N" or "P").
- 2) Install an engine tachometer at a location visible from the driver's compartment and mark the

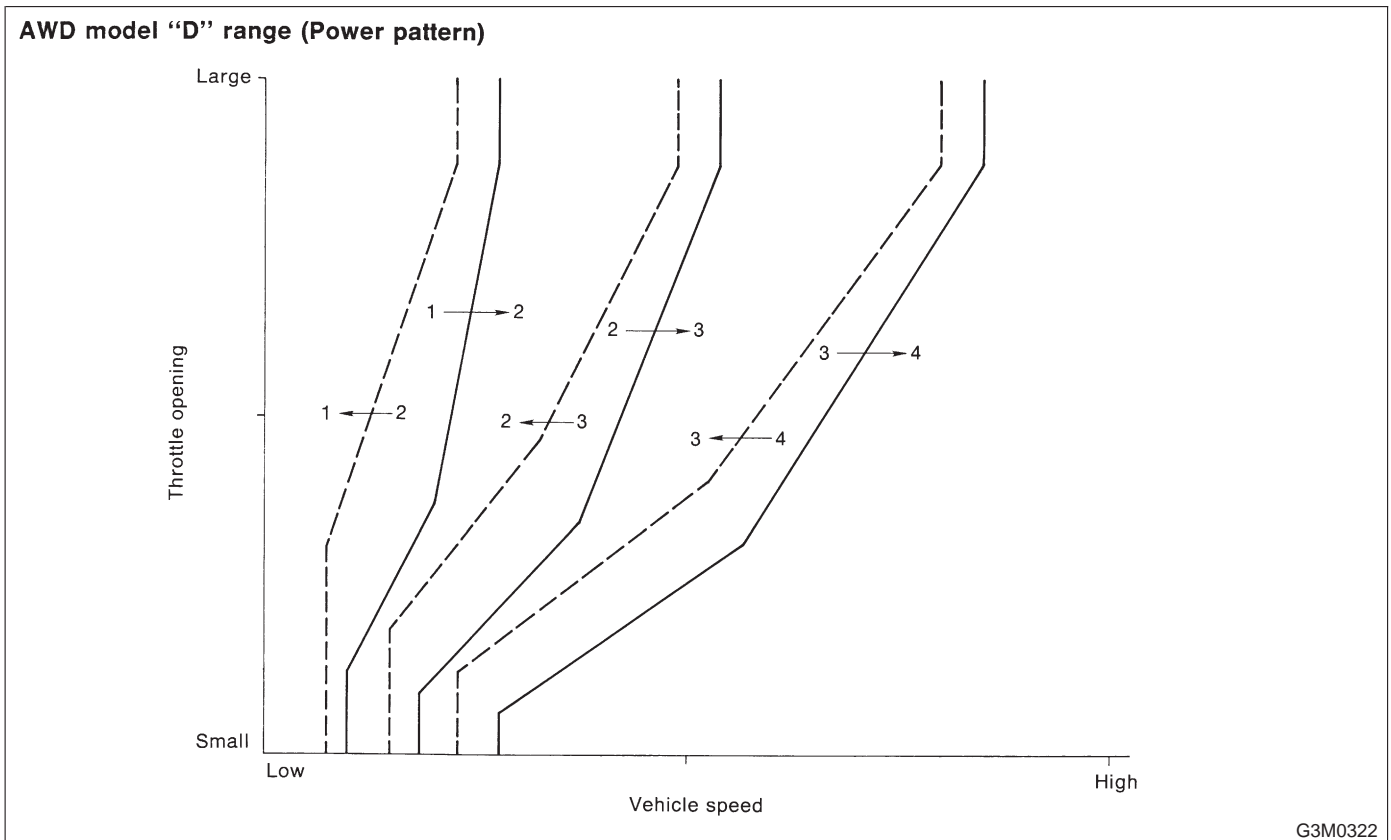

3. ENGINE BRAKE OPERATION

Engine brake operation:

- D range* → 4th gear
- 3 range* → 3rd gear
- 2 range* → 2nd gear
- 1 range* → 1st gear

4. AWD FUNCTION

If "tight-corner braking" occurs when the steering wheel is fully turned at low speed:

- 1) Determine the applicable trouble code and check the corresponding duty solenoid C (transfer) for improper operation.
- 2) If the solenoid is operating properly, check transfer clutch pressure.
- 3) If oil pressure is normal but "tight-corner braking" occurs:
Check the transfer control valve for sticking, and the transfer clutch facing for wear. <Ref. to 3-2 [W20B0].> and <Ref. to 3-2 [W21B0].>

7. Stall Test

A: MEASUREMENT

1. GENERAL INFORMATION

The stall test is of extreme importance in diagnosing the condition of the automatic transmission and the engine. It should be conducted to measure the engine stall speeds in R and 2 ranges.

Purposes of the stall test:

- 1) To check the operation of the automatic transmission clutch.
- 2) To check the operation of the torque converter clutch.
- 3) To check engine performance.

2. TEST METHODS

- 1) Preparations before test:
 - (1) Check that throttle valve opens fully.
 - (2) Check that engine oil level is correct.
 - (3) Check that coolant level is correct.
 - (4) Check that ATF level is correct.
 - (5) Check that differential gear oil level is correct.
 - (6) Increase ATF temperature to 50 to 80°C (122 to 176°F) by idling the engine for approximately 30 minutes (with select lever set to "N" or "P").
- 2) Install an engine tachometer at a location visible from the driver's compartment and mark the

stall speed range on the tachometer scale.

- 3) Place the wheel chocks at the front and rear of all wheels and engage the parking brake.
- 4) Move the manual linkage to ensure it operates properly, and shift the select lever to the 2 range.
- 5) While forcibly depressing the foot brake pedal, gradually depress the accelerator pedal until the engine operates at full throttle.

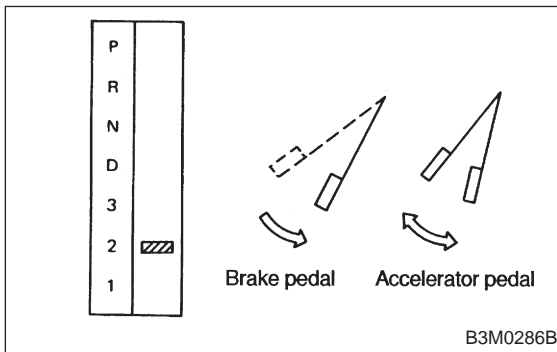

- 6) When the engine speed is stabilized, read that speed quickly and release the accelerator pedal.
- 7) Shift the select lever to Neutral, and cool down the engine by idling it for more than one minute.
- 8) Record the stall speed.
- 9) If stall speed in 2 range is higher than specifications, low clutch slipping and 2-4 brake

slipping may occur. To identify it, conduct the same test as above in D range.

- 10) Perform the stall tests with the select lever in the R range.

NOTE:

- Do not continue the stall test for MORE THAN FIVE SECONDS at a time (from closed throttle, fully open throttle to stall speed reading). Failure to follow this instruction causes the engine oil and ATF to deteriorate and the clutch and brake to be adversely affected.

Be sure to cool down the engine for at least one minute after each stall test with the select lever set in the P or N range and with the idle speed lower than 1,200 rpm.

- If the stall speed is higher than the specified range, attempt to finish the stall test in as short a time as possible, in order to prevent the automatic transmission from sustaining damage.

Stall speed (at sea level):

- 2200 cc 2,200 — 2,600 rpm**
- 2500 cc 2,200 — 2,600 rpm**
- OUTBACK 2,300 — 2,700 rpm**

3. EVALUATION

Stall speed (at sea level)	Position	Cause
Less than specifications	2 R	<ul style="list-style-type: none"> ● Throttle valve not fully open ● Erroneous engine operation ● Torque converter clutch's one-way clutch slipping
Greater than specifications	D	<ul style="list-style-type: none"> ● Low clutch slipping ● One-way clutch malfunctioning
	R	<ul style="list-style-type: none"> ● Line pressure too low ● Reverse clutch slipping ● Low & reverse brake slipping
	2	<ul style="list-style-type: none"> ● Line pressure too low ● Low clutch slipping ● 2-4 brake slipping

8. Time Lag Test

A: INSPECTION

1. GENERAL INFORMATION

If the shift lever is shifted while the engine is idling, there will be a certain time elapse or lag before the shock can be felt. This is used for checking the condition of the low clutch, reverse clutch, low & reverse brake and one-way clutch.

CAUTION:

- Perform the test at normal operation fluid temperature 60 to 80°C (140 to 176°F).
- Be sure to allow a one minute interval between tests.
- Make three measurements and take the average value.

2. TEST METHODS

- 1) Fully apply the parking brake.
- 2) Start the engine.
Check idling speed (A/C OFF).
"N" range: 800±100 rpm
- 3) Shift the shift lever from "N" to "D" range.
Using a stop watch, measure the time it takes from shifting the lever until the shock is felt.
Time lag: Less than 1.2 seconds
- 4) In same manner, measure the time lag for "N" → "R".
Time lag: Less than 1.5 seconds

3. EVALUATION

- 1) If "N" → "D" time lag is longer than specified:
 - Line pressure too low
 - Low clutch worn
 - One-way clutch not operating properly
- 2) If "N" → "R" time lag is longer than specified:
 - Line pressure too low
 - Reverse clutch worn
 - Low & reverse brake worn

9. Line Pressure Test

A: MEASUREMENT

1. GENERAL INFORMATION

If the clutch or the brake shows a sign of slippage or shifting sensation is not correct, the line pressure should be checked.

- Excessive shocks during upshifting or shifting takes place at a higher point than under normal circumstances, may be due to the line pressure being too high.
 - Slippage or inability to operate the vehicle may, in most cases, be due to loss of oil pressure for the operation of the clutch, brake or control valve.
- 1) Line pressure measurement (under no load)

CAUTION:

- Before measuring line pressure, jack-up all wheels.
- Maintain temperature of ATF at approximately 50°C (122°F) during measurement. (ATF will reach the above temperature after idling the engine for approximately 30 minutes with select lever in "N" or "P".)

- 2) Line pressure measurement (under heavy load)

CAUTION:

- Before measuring line pressure, apply both foot and parking brakes with all wheels chocked (Same as for "stall" test conditions).
- Measure line pressure when select lever is in "R", "2" with engine under stall conditions.
- Measure line pressure within 5 seconds after shifting the select lever to each position. (If line pressure needs to be measured again, allow the engine to idle and then stop. Wait for at least one minute before measurement.)
- Maintain the temperature of ATF at approximately 50°C (122°F) during measurement. (ATF will reach the above temperature after idling the engine for approximately 30 minutes with the select lever in "N" or "P".)

8. Time Lag Test

A: INSPECTION

1. GENERAL INFORMATION

If the shift lever is shifted while the engine is idling, there will be a certain time elapse or lag before the shock can be felt. This is used for checking the condition of the low clutch, reverse clutch, low & reverse brake and one-way clutch.

CAUTION:

- Perform the test at normal operation fluid temperature 60 to 80°C (140 to 176°F).
- Be sure to allow a one minute interval between tests.
- Make three measurements and take the average value.

2. TEST METHODS

- 1) Fully apply the parking brake.
- 2) Start the engine.
Check idling speed (A/C OFF).
"N" range: 800±100 rpm
- 3) Shift the shift lever from "N" to "D" range.
Using a stop watch, measure the time it takes from shifting the lever until the shock is felt.
Time lag: Less than 1.2 seconds
- 4) In same manner, measure the time lag for "N" → "R".
Time lag: Less than 1.5 seconds

3. EVALUATION

- 1) If "N" → "D" time lag is longer than specified:
 - Line pressure too low
 - Low clutch worn
 - One-way clutch not operating properly
- 2) If "N" → "R" time lag is longer than specified:
 - Line pressure too low
 - Reverse clutch worn
 - Low & reverse brake worn

9. Line Pressure Test

A: MEASUREMENT

1. GENERAL INFORMATION

If the clutch or the brake shows a sign of slippage or shifting sensation is not correct, the line pressure should be checked.

- Excessive shocks during upshifting or shifting takes place at a higher point than under normal circumstances, may be due to the line pressure being too high.
 - Slippage or inability to operate the vehicle may, in most cases, be due to loss of oil pressure for the operation of the clutch, brake or control valve.
- 1) Line pressure measurement (under no load)

CAUTION:

- Before measuring line pressure, jack-up all wheels.
- Maintain temperature of ATF at approximately 50°C (122°F) during measurement. (ATF will reach the above temperature after idling the engine for approximately 30 minutes with select lever in "N" or "P".)

- 2) Line pressure measurement (under heavy load)

CAUTION:

- Before measuring line pressure, apply both foot and parking brakes with all wheels chocked (Same as for "stall" test conditions).
- Measure line pressure when select lever is in "R", "2" with engine under stall conditions.
- Measure line pressure within 5 seconds after shifting the select lever to each position. (If line pressure needs to be measured again, allow the engine to idle and then stop. Wait for at least one minute before measurement.)
- Maintain the temperature of ATF at approximately 50°C (122°F) during measurement. (ATF will reach the above temperature after idling the engine for approximately 30 minutes with the select lever in "N" or "P".)

2. TEST METHODS

1) Temporarily attach the ST to a suitable place in the driver's compartment, remove the blind plug located in front of the toe board and pass the hose of the ST to the engine compartment.

ST 498575400 OIL PRESSURE GAUGE ASSY

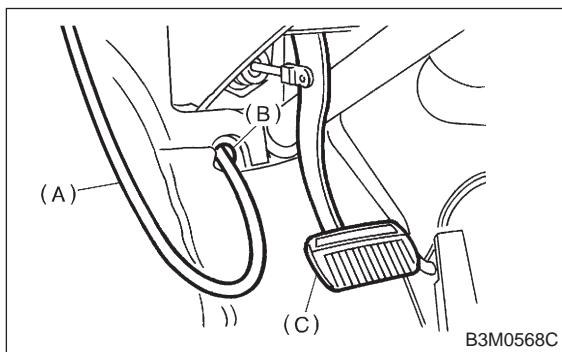

- (A) Pressure gauge hose
- (B) Hole in toe board (blank cap hole)
- (C) Brake pedal

2) Remove the test plug and install ST instead.

ST 498897200 OIL PRESSURE GAUGE ADAPTER

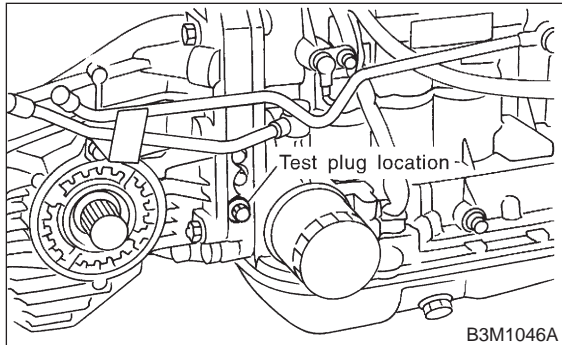

3) Connect ST1 with ST2.

ST1 498897200 OIL PRESSURE GAUGE ADAPTER

ST2 498575400 OIL PRESSURE GAUGE ASSY

4) Check for duty ratio changes by opening and closing throttle valve using Subaru Select Monitor.
(1) Insert the cartridge to Subaru Select Monitor.

ST 24082AA090 CARTRIDGE

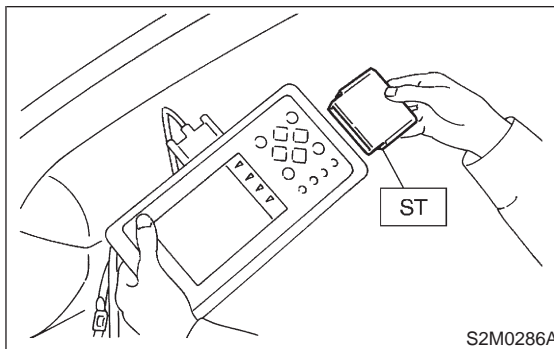

(2) Connect Subaru Select Monitor to data link connector.

5) Check line pressure in accordance with the following chart.

3. EVALUATION

NOTE:

- Under no load: "D"
 - Under full load: "R", "2"
- (With engine running at stall speed)

Standard line pressure		
Range position	Line pressure duty ratio (%)	Line pressure kPa (kg/cm ² , psi)
2	5	1,128 — 1,304 (11.5 — 13.3, 164 — 189)
R	5	1,520 — 1,716 (15.5 — 17.5, 220 — 249)
D	95	304 — 412 (3.1 — 4.2, 44 — 60)

10. Transfer Clutch Pressure Test

A: MEASUREMENT

1. TEST METHODS

Check transfer clutch pressure in accordance with the following chart in the same manner as with line pressure.

ST 499897700 OIL PRESSURE ADAPTER SET

ST 498575400 OIL PRESSURE GAUGE ASSY

AWD mode: "D" range

FWD mode: "P" range, engine speed 2,000 rpm

CAUTION:

Before setting in FWD mode, install spare fuse on FWD mode switch.

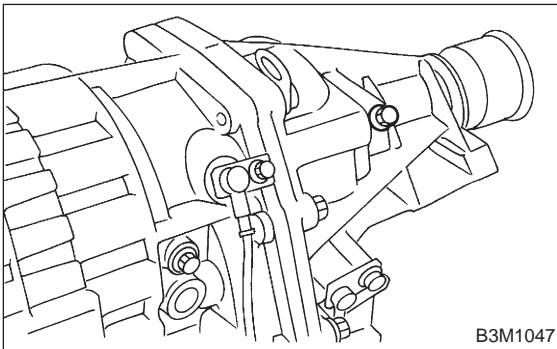

2. EVALUATION

NOTE:

If oil pressure is not produced or if it does not change in the AWD mode, the duty solenoid C or transfer valve assembly may be malfunctioning. If oil pressure is produced in the FWD mode, the problem is similar to that in the AWD mode.

Standard transfer clutch pressure kPa (kg/cm ² , psi)		
Duty ratio (%)	AWD mode	FWD mode
5	951 — 1,089 (9.7 — 11.1, 138 — 158)	—
60	226 — 294 (2.3 — 3.0, 33 — 43)	—
95	—	0 (0, 0)

11. Overall Transmission

A: SECTIONS THAT CAN BE DETACHED/ASSEMBLED

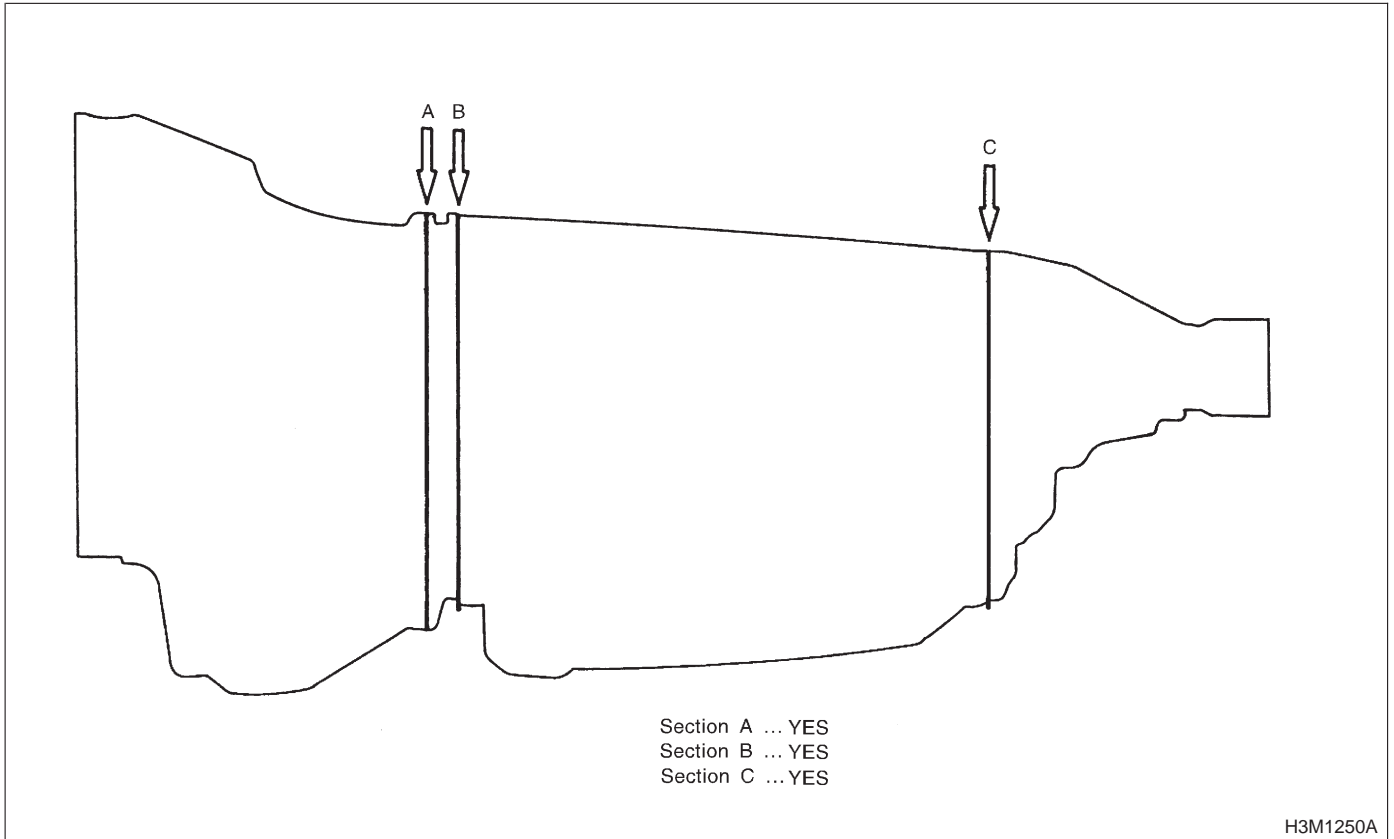

B: DISASSEMBLY

1. EXTERNAL PARTS

1) Place the transmission unit on a work bench, with the oil pan facing down.

CAUTION:

Be careful not to bend or damage external parts.

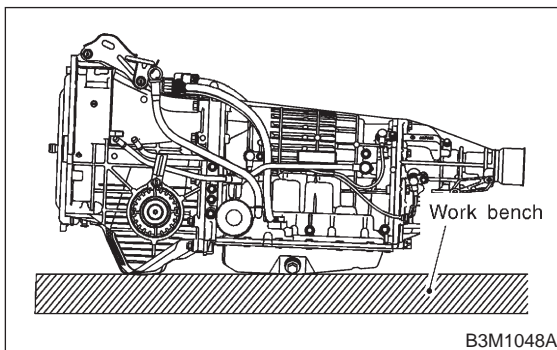

- 2) Remove the drain plug, and drain differential oil. Tighten the plug temporarily after draining.
- 3) Remove the drain plug, and drain automatic transmission fluid (ATF). Tighten the plug temporarily after draining.

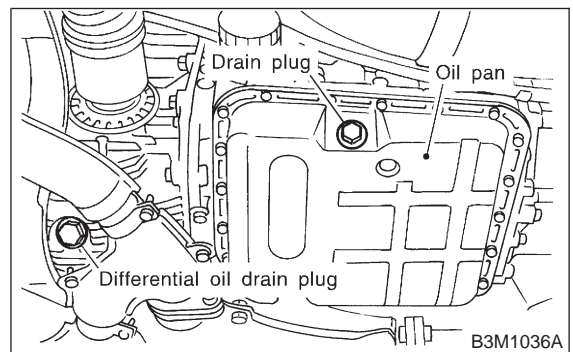

4) Extract the torque converter clutch assembly.

NOTE:

- Extract the torque converter clutch horizontally. Be careful not to scratch the bushing inside the oil pump shaft.
- Note that oil pump shaft also comes out.

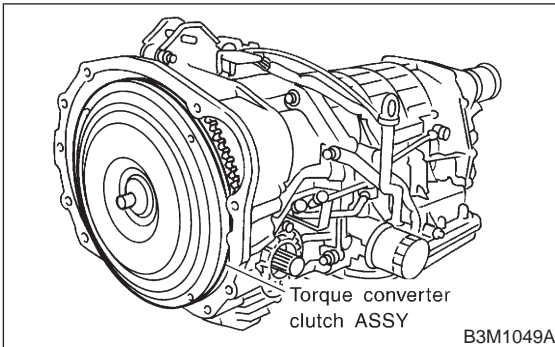

5) Remove the input shaft.

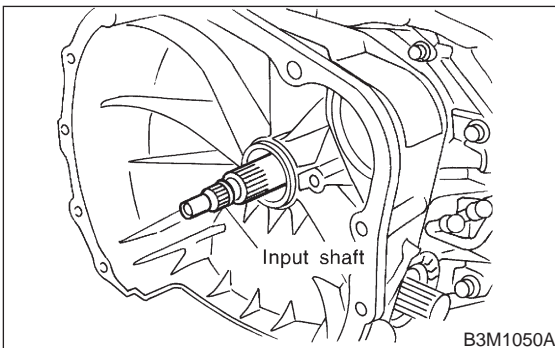

6) Remove the pitching stopper bracket.

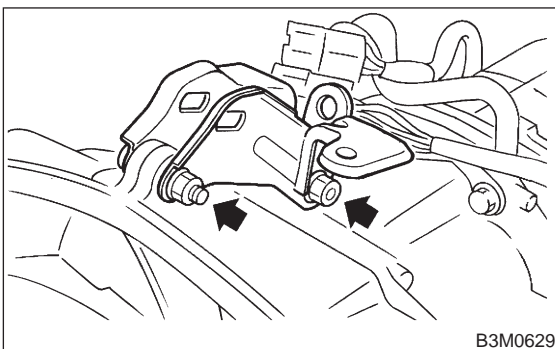

7) Remove harnesses from bracket.

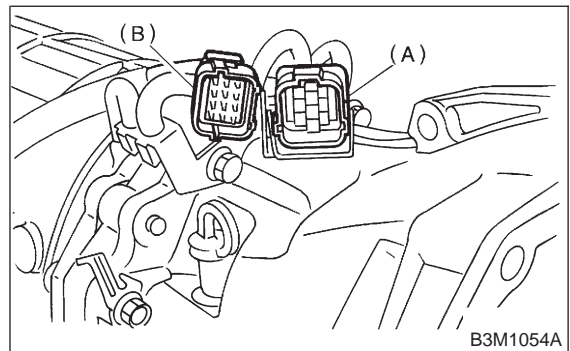

- (A) Transmission harness
- (B) Inhibitor switch harness

8) Disconnect the air breather hose.

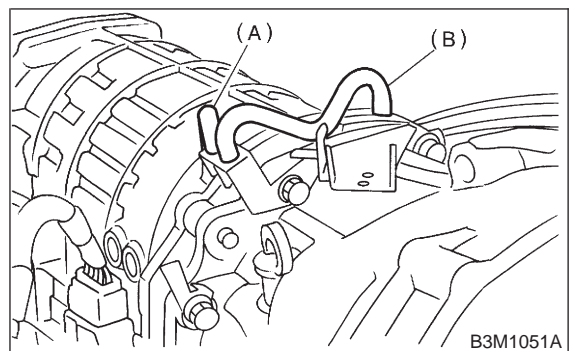

- (A) Air breather hose (Transmission case)
- (B) Air breather hose (Oil pump housing)

9) Remove the oil charger pipe, and remove the O-ring from the flange face. Attach the O-ring to the pipe.

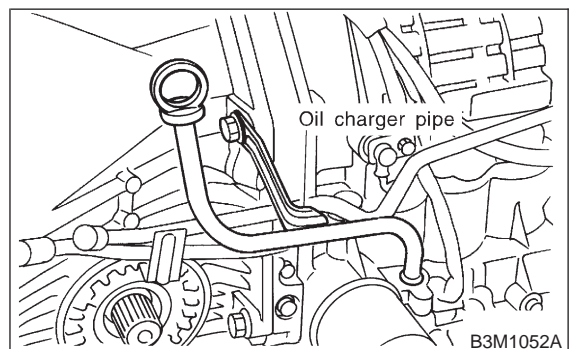

10) Remove the oil cooler inlet and outlet pipes.

CAUTION:

When removing outlet pipes, be careful not to lose balls and springs used with retaining screws.

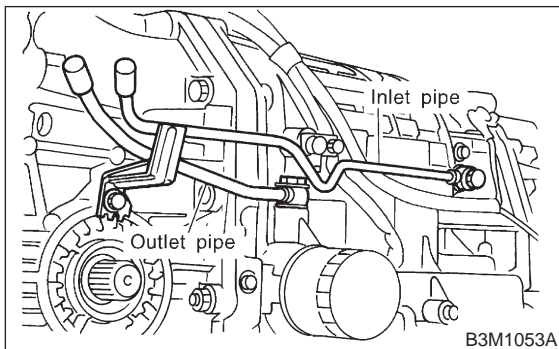

2. SEPARATION OF EACH SECTION

1) Separation of torque converter clutch case and transmission case sections

CAUTION:

- Be careful not to damage the oil seal and bushing inside the torque converter clutch case by the oil pump cover.
- Be careful not to lose the rubber seal.

NOTE:

Separate these cases while tapping lightly on the housing.

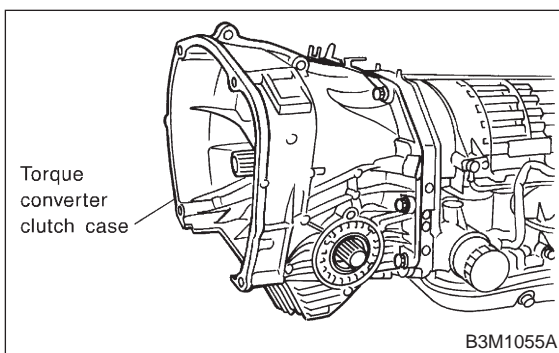

2) Separation of transmission case and extension sections

(1) Remove vehicle speed sensor 1 (rear).

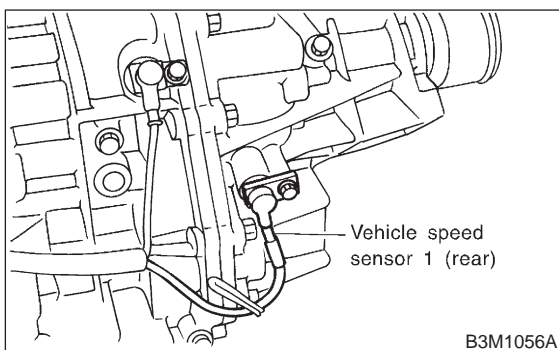

(2) Separation of transmission case and extension case sections

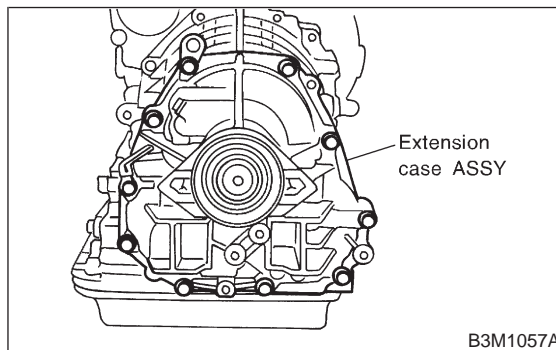

3. TRANSMISSION CASE SECTION

1) Remove the reduction driven gear.

(1) Straighten the staked portion, and remove the lock nut.

NOTE:

Set the range selector lever to "P".

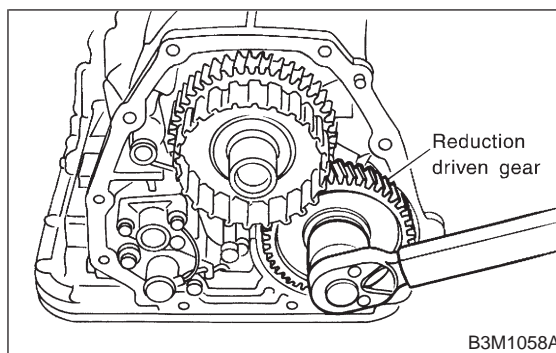

(2) Using the ST1 and ST2, extract the reduction driven gear.

NOTE:

- ST1 499737000 PULLER
- ST2 899524100 PULLER SET

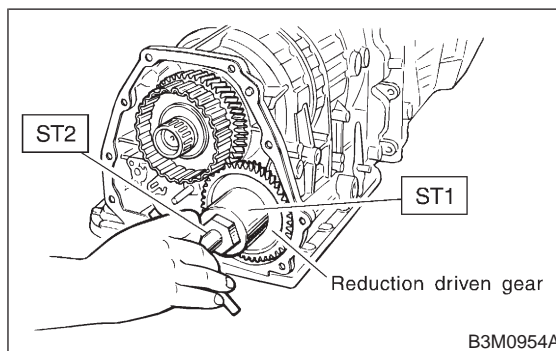

(3) Using the ST, extract the reduction drive gear.

ST 499737100 PULLER SET

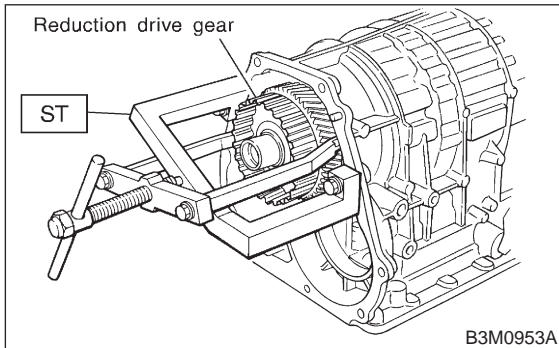

2) Remove transfer valve body and duty solenoid C (Transfer).

- (1) Disconnect connector from duty solenoid C (Transfer).
- (2) Remove transfer valve body and duty solenoid C (Transfer).

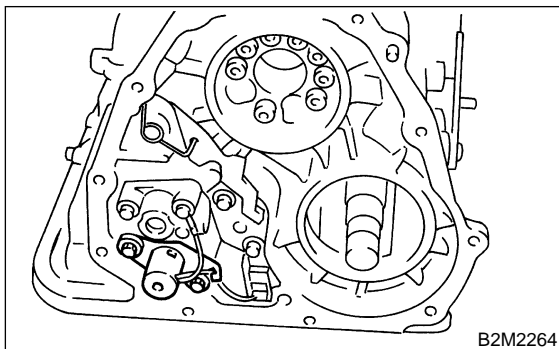

(3) Pull out inlet filter

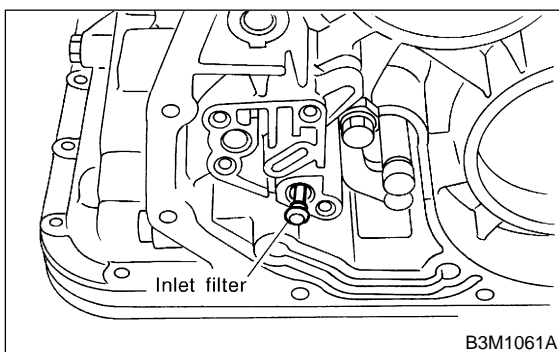

3) Remove the parking pawl, return spring and shaft.

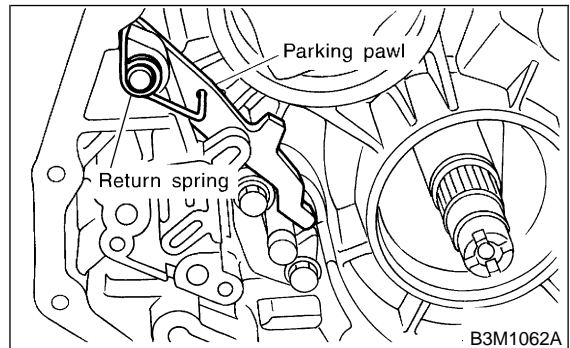

4) Loosen the taper roller bearing mounting bolts.

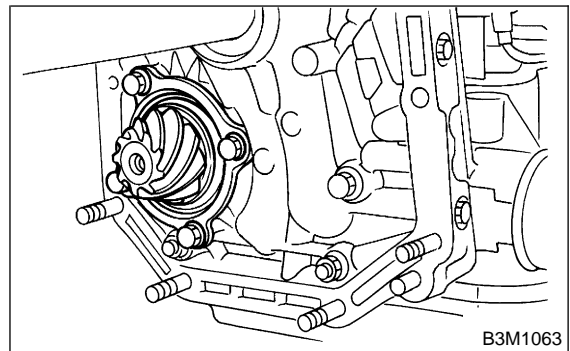

5) Place two wooden blocks on the workbench, and stand the transmission case with its rear end facing down.

CAUTION:

- Be careful not to scratch the rear mating surface of the transmission case.
- Note that the parking rod and drive pinion protrude from the mating surface.

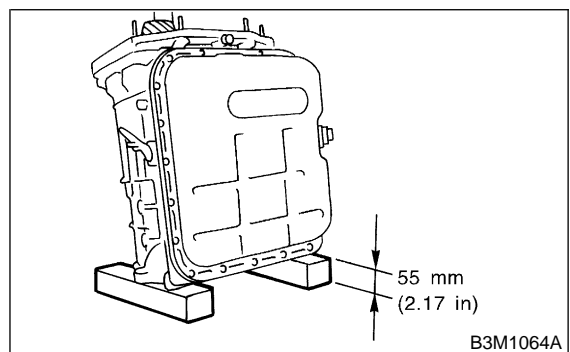

3-2 [W11B3]

11. Overall Transmission

SERVICE PROCEDURE

6) Remove the oil pan.

NOTE:

Use a scraper to remove oil pan.

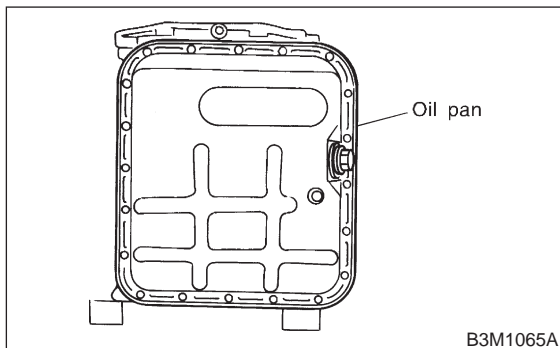

7) Disconnect the harness connectors for the solenoids, duty solenoids, ATF temperature sensor and the ground cord.

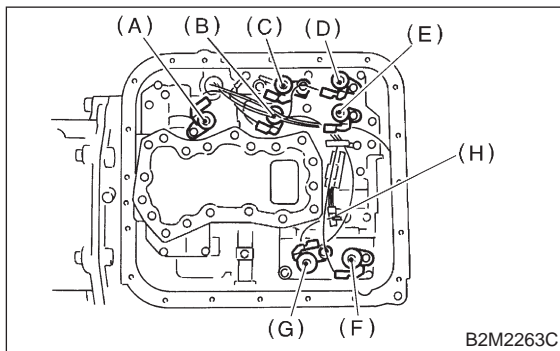

- (A) Lock-up duty solenoid (Blue)
- (B) Low clutch timing solenoid (Gray)
- (C) Line pressure duty solenoid (Red)
- (D) Shift solenoid 2 (Yellow)
- (E) Shift solenoid 1 (Green)
- (F) 2-4 brake timing solenoid (Black)
- (G) 2-4 brake duty solenoid (Red)
- (H) ATF temperature sensor

8) Remove the control valve body.

CAUTION:

When removing control valve body, be careful not to interfere with transfer duty solenoid C wiring.

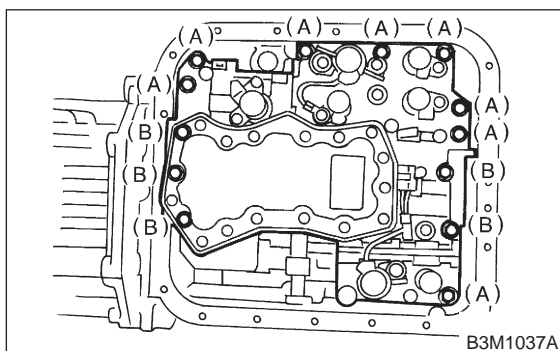

9) Remove vehicle speed sensor 2 (front) and torque converter turbine speed sensor.

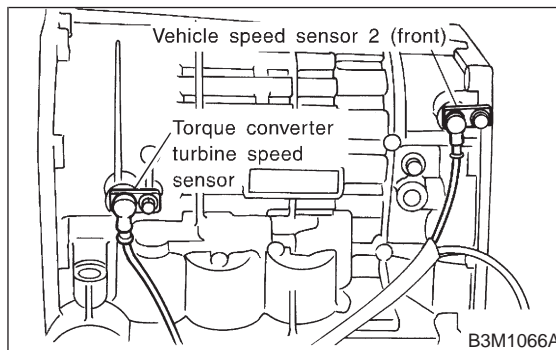

10) Remove transmission harness.

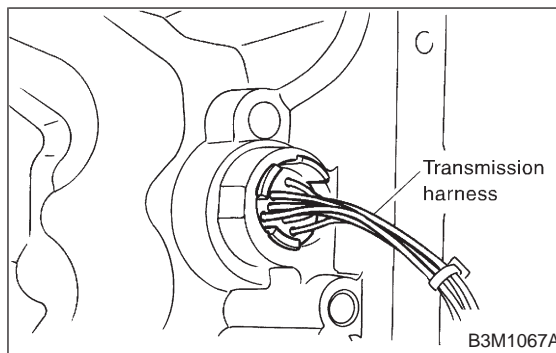

11) Remove the oil pump housing.

CAUTION:

Be careful not to lose the total end play adjusting thrust washer.

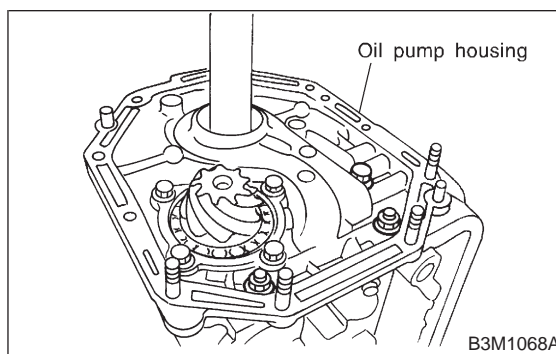

12) Remove 2-4 brake seal.

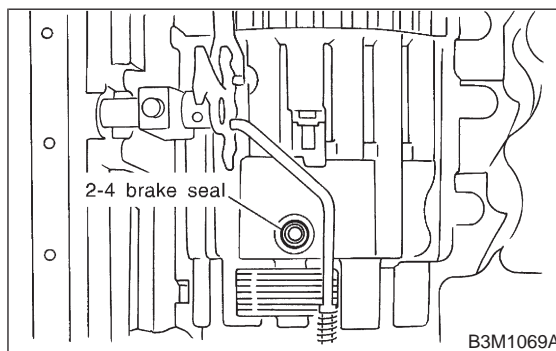

13) Take out the high clutch and reverse clutch assembly.

CAUTION:
Be careful not to lose thrust needle bearing.

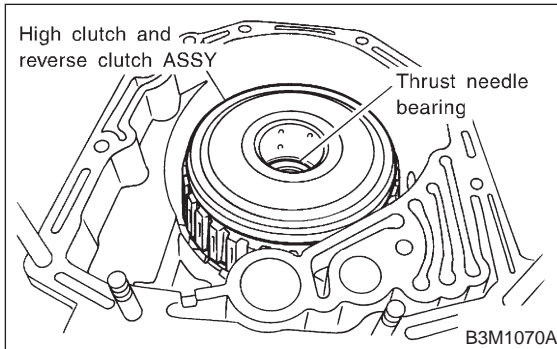

14) Take out the high clutch hub and the thrust bearing.

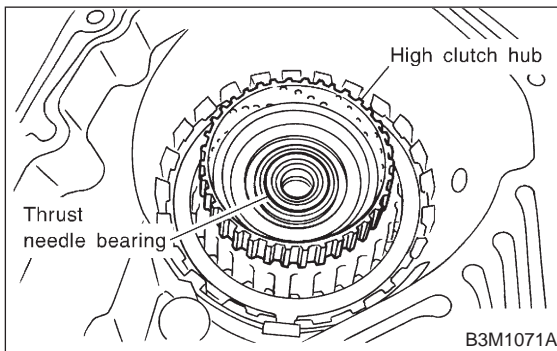

15) Take out the front sun gear and the thrust bearing.

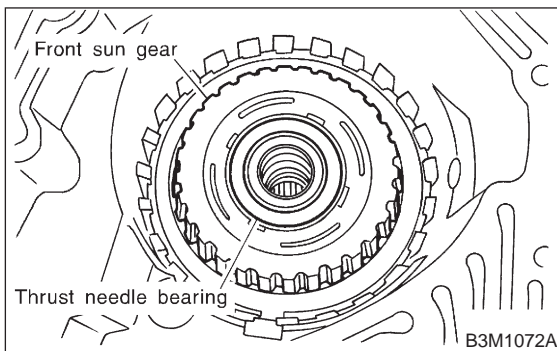

16) Pull out leaf spring.

CAUTION:
Be careful not to bend leaf spring during removal.

NOTE:
Remove it while pressing down on lower leaf spring.

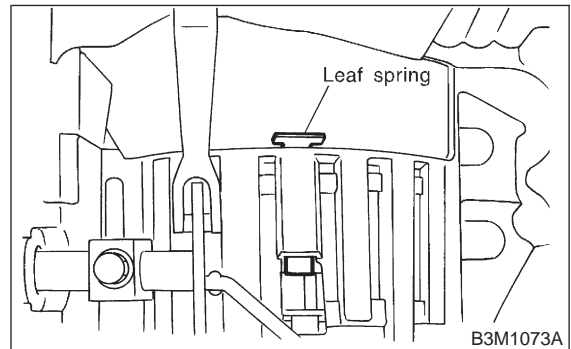

17) Remove snap ring and thrust needle bearing.

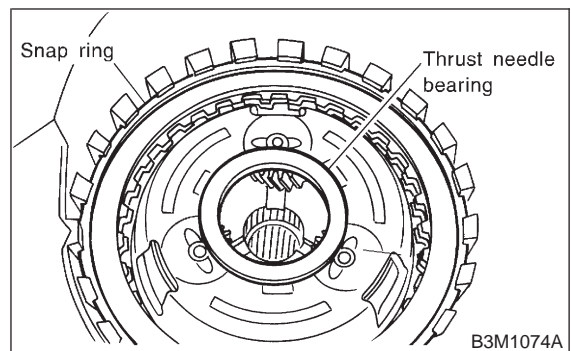

18) Take out retaining plate, drive plate and driven plate of 2-4 brake.

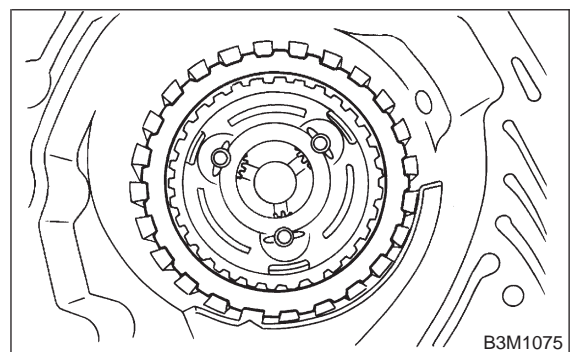

3-2 [W11B3]

11. Overall Transmission

SERVICE PROCEDURE

19) Take out the thrust needle bearing, planetary gear assembly and the low clutch assembly.

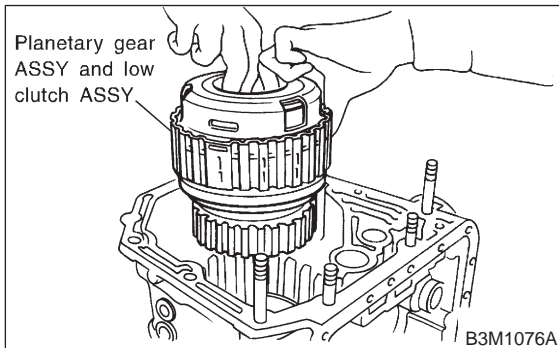

20) Remove snap ring.

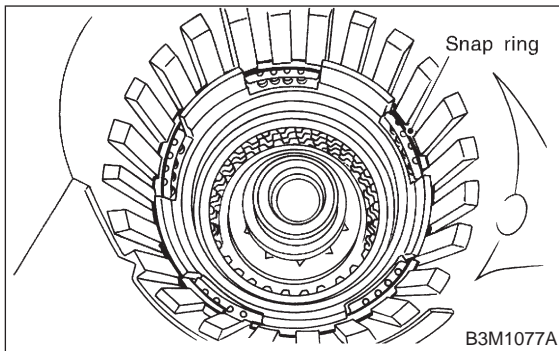

21) Take out 2-4 brake return spring.

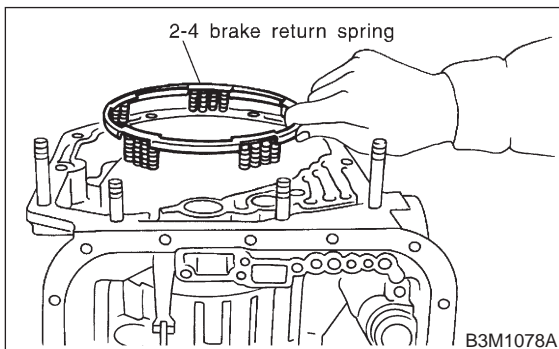

22) Take out 2-4 brake piston and piston retainer.

CAUTION:
When removing the brake piston 2-4 and piston retainer, be careful not to rub or bump them against the transmission case.

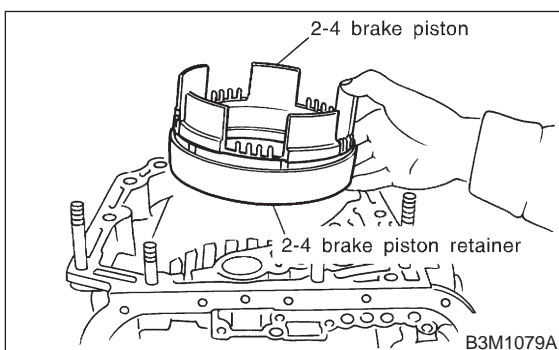

23) Separate 2-4 brake piston and piston retainer.

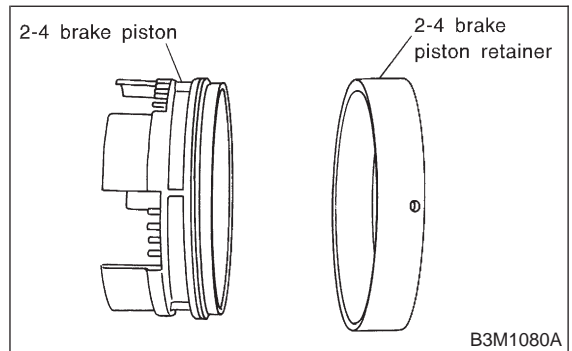

24) Pull out leaf spring.

CAUTION:
Be careful not to bend leaf spring during removal.

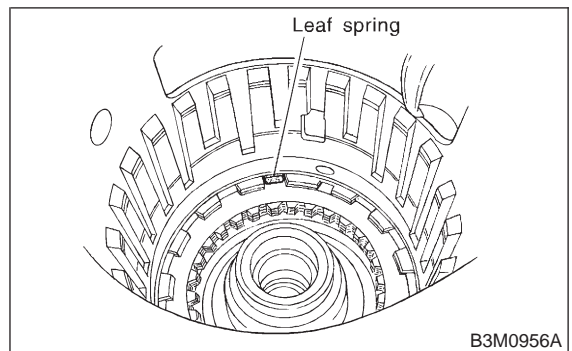

25) Remove snap ring.

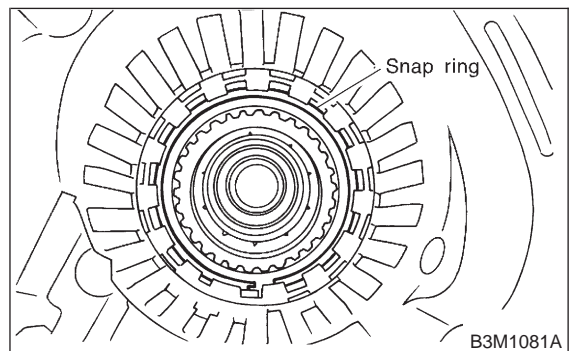

26) Take out retaining plate, drive plate, driven plate and dish plate.

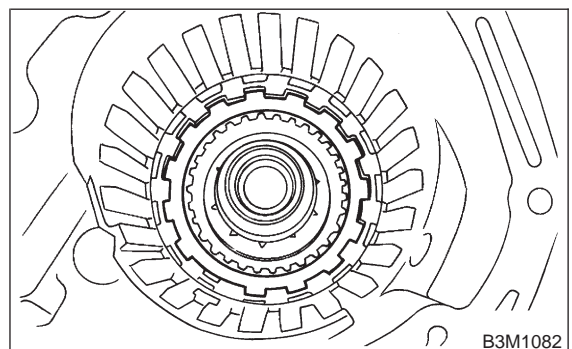

27) Turning the case upside down, take out the one-way clutch inner race, retainer and wave spring.

NOTE:

After loosening all socket bolts, place the side of the transmission case on the floor.

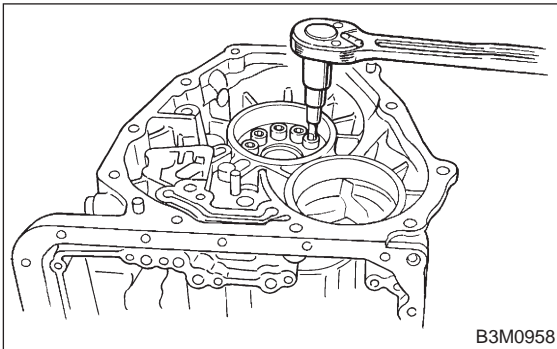

28) Take out the low & reverse piston by applying compressed air.

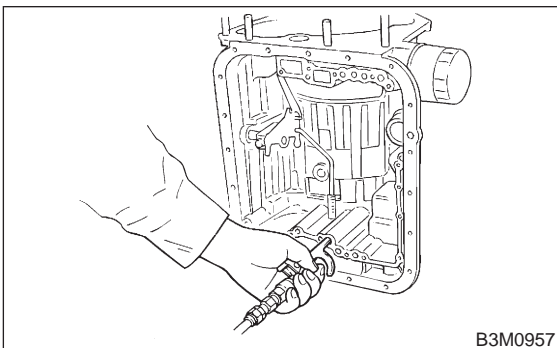

29) Using ST, remove ATF filter.

NOTE:

If any of the clutches or brakes are abnormally worn, replace ATF filter and oil seal with new ones.

ST 498545400 OIL FILTER WRENCH

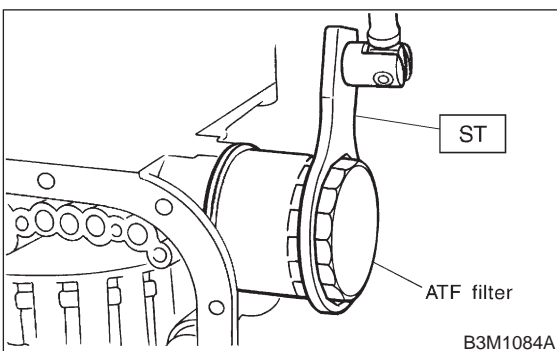

30) Pull off the straight pin of manual lever.

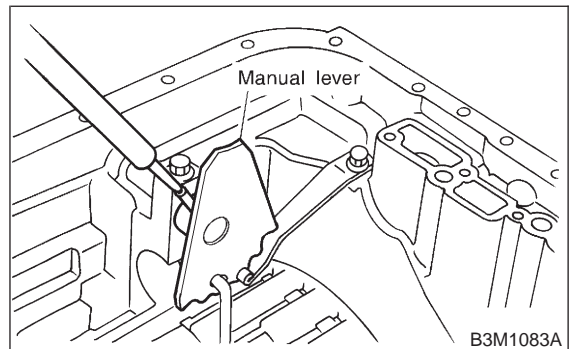

31) Remove bolts securing select lever, then remove select lever, manual lever and parking rod.

CAUTION:

Be careful not to damage the lips of the press-fitted oil seal in the case.

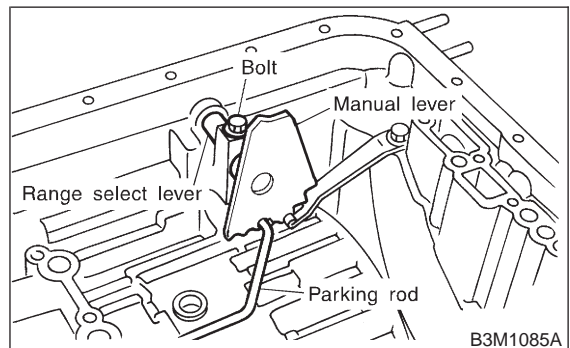

32) Remove the detention spring.

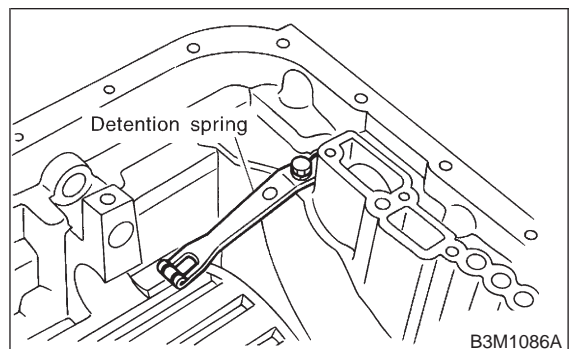

33) Remove the inhibitor switch.

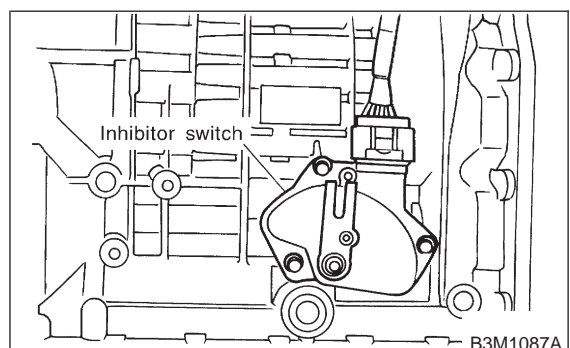

34) Remove parking support.

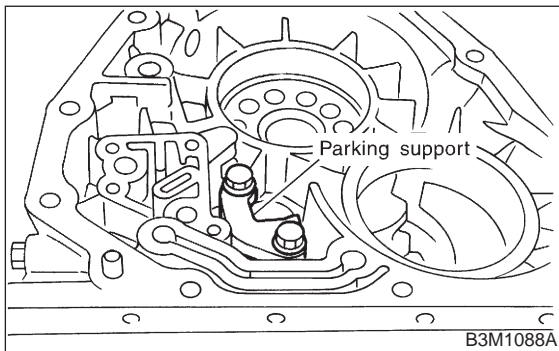

4. TORQUE CONVERTER CLUTCH CASE SECTION

1) Wrap the axle shaft serration with vinyl tape.

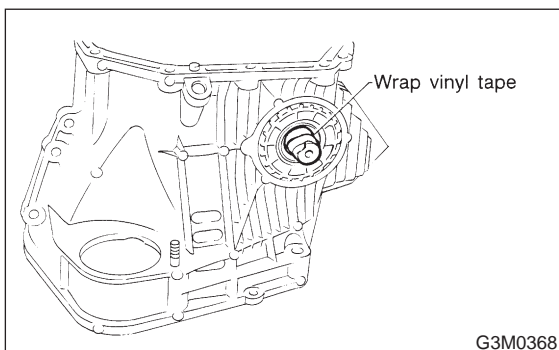

2) Remove the differential side retainer with ST.

CAUTION:

Hold the differential case assembly by hand to avoid damaging retainer mounting hole of the torque converter clutch case and speedometer gears.

ST 499787000 WRENCH ASSY

3) Extract the axle shaft with ST1 and ST2.

CAUTION:

Do not reuse the circlip.

ST1 499095500 REMOVER

ST2 499247300 INSTALLER

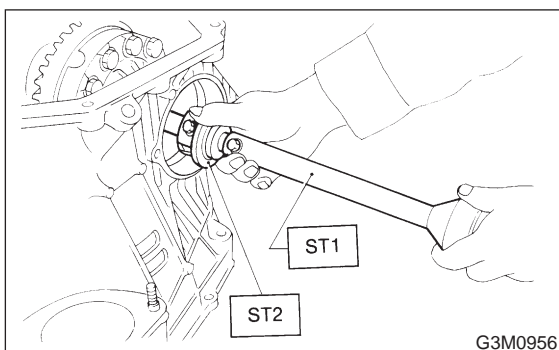

4) Remove the differential case assembly.

CAUTION:

- Remove the seal pipe if it is attached. (Reusing is not allowed.)
- Be careful not to damage the retainer mounting hole of the torque converter clutch case and the speedometer gears.

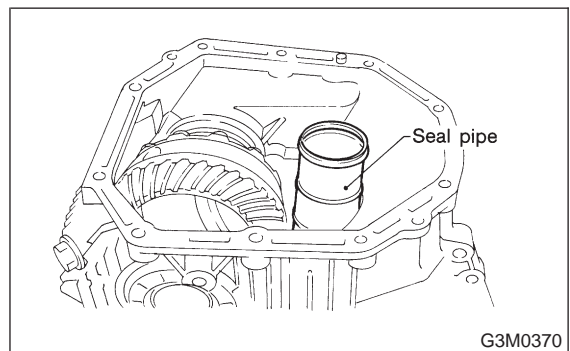

5. EXTENSION SECTION

1) Take out the transfer clutch by lightly tapping the end of the rear drive shaft.

CAUTION:

Be careful not to damage the oil seal in the extension.

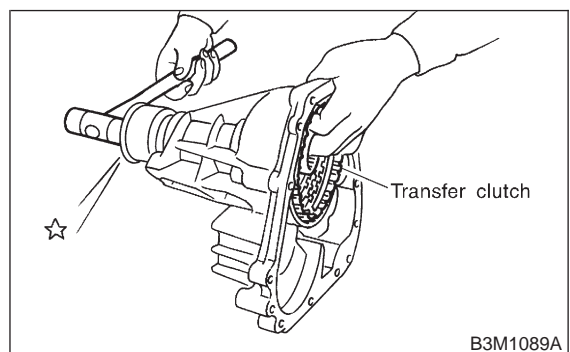

2) Remove the transfer pipe.

CAUTION:

Be careful not to bend the pipe.

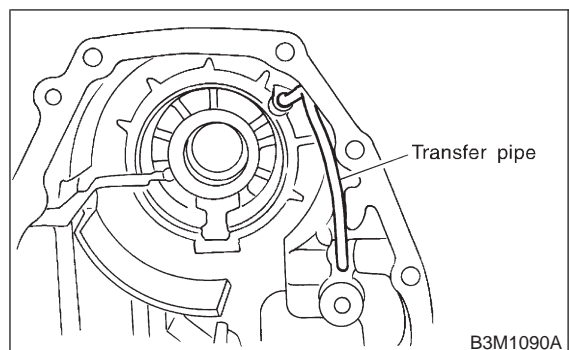

C: ASSEMBLY OF OVERALL TRANSMISSION

1. TORQUE CONVERTER CLUTCH CASE SECTION

1) Check the appearance of each component and clean.

CAUTION:

Make sure each part is free of harmful cuts, damage and other faults.

2) Force-fit the oil seal to the torque converter clutch case with ST.

ST 398437700 DRIFT

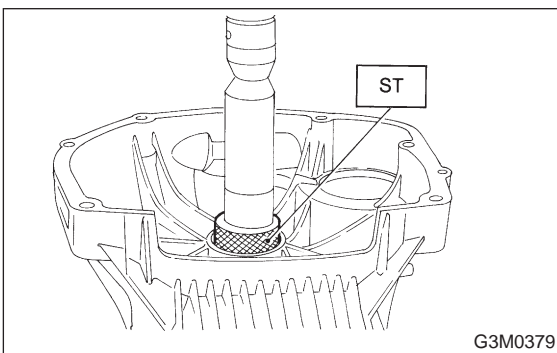

3) Install the differential assembly to the case, paying special attention not to damage the speedometer gears (drive and driven) and the inside of the case (particularly, the differential side retainer contact surface).

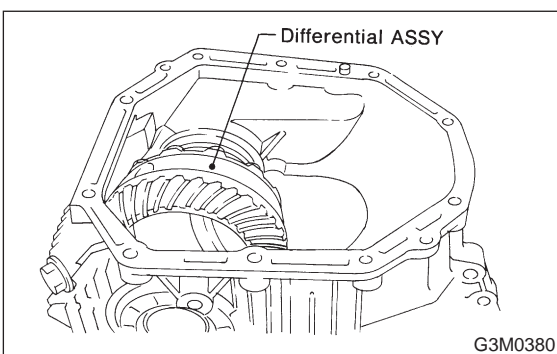

4) Install the circlip to the axle shaft, insert the shaft into the differential assembly, and tap it into position with a plastic hammer.

CAUTION:

- If no play is felt, check whether the shaft is fully inserted. If shaft insertion is correct, replace the axle shaft.
- Be sure to use a new circlip.

Thrust play:

0.3 — 0.5 mm (0.012 — 0.020 in)

5) Wrap vinyl tape around the splined portion of the axle shaft.

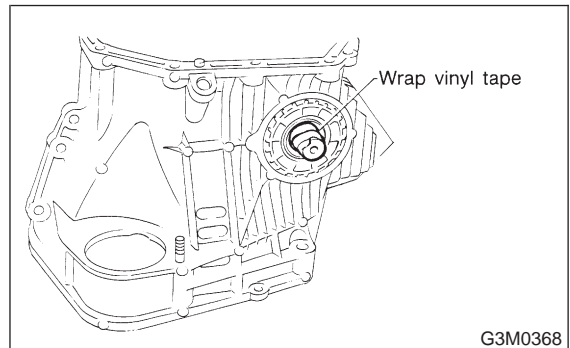

6) Install the oil seal and outer race (taper roller bearing) to the differential side retainer. Then screw in the retainer and the O-ring after coating the threads with oil.

CAUTION:

- Pay attention not to damage the oil seal lips.
- Do not confuse the RH and LH oil seals.
- Keep the O-ring removed from the retainer.

7) Using the ST, screw in the retainer until light contact is felt.

NOTE:

Screw in the RH side slightly deeper than the LH side.

ST 499787000 WRENCH ASSY

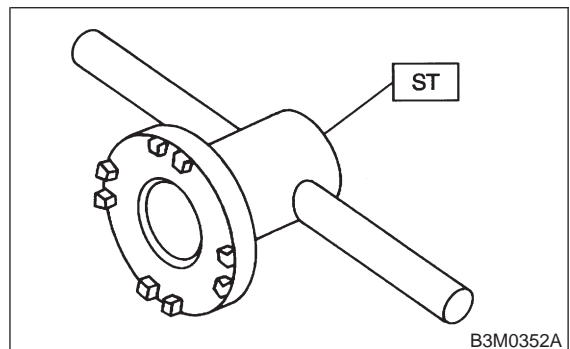

8) Hypoid gear backlash adjustment and tooth contact check

(1) Assemble the drive pinion assembly to the oil pump housing.

CAUTION:

- Be careful not to bend the shims.
- Be careful not to force the pinion against the housing bore.

3-2 [W11C1]

11. Overall Transmission

SERVICE PROCEDURE

(2) Tighten four bolts to secure the roller bearing.

Tightening torque:

41 ± 3 N·m (4.2 ± 0.3 kg·m, 30.4 ± 2.2 ft·lb)

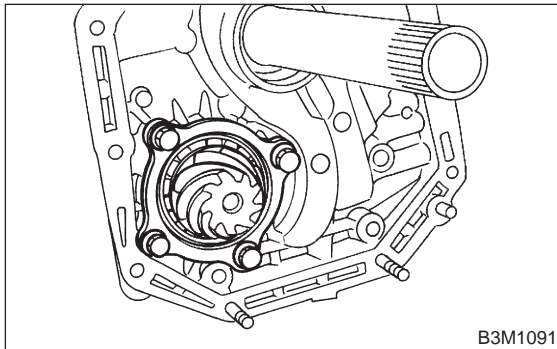

(3) Install the oil pump housing assembly to the torque converter clutch case, and secure evenly by tightening four bolts.

CAUTION:

- Thoroughly remove the liquid gasket from the case mating surface beforehand.
- Use an old gasket or an aluminum washer so as not to damage the mating surface of the housing.

Tightening torque:

41 ± 3 N·m (4.2 ± 0.3 kg·m, 30.4 ± 2.2 ft·lb)

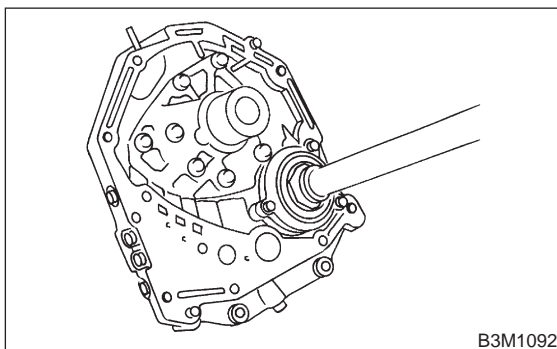

(4) Rotate the drive pinion several times with ST1 and ST2.

- ST1 498937100 HOLDER
ST2 499787100 WRENCH

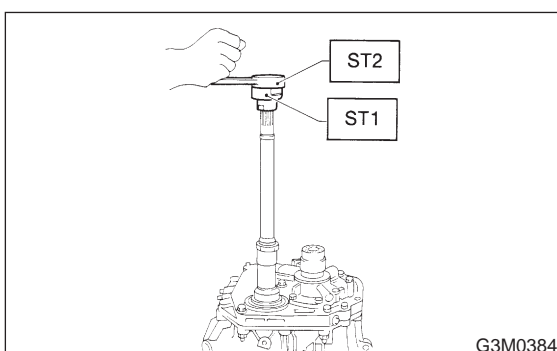

(5) Tighten the LH retainer until contact is felt while rotating the shaft. Then loosen the RH retainer. Keep tightening the LH retainer and loosening the RH retainer until the pinion shaft can no longer be turned. This is the “zero” state.

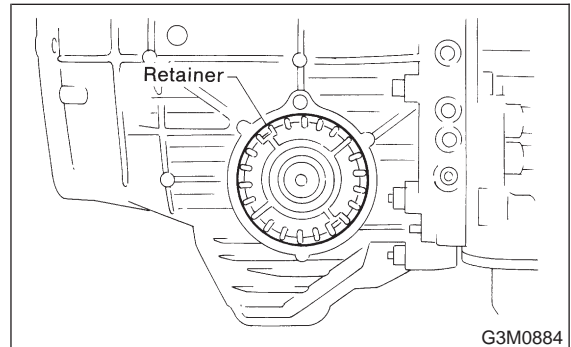

(6) After the “zero” state is established, back off the LH retainer 3 notches and secure it with the lock plate. Then back off the RH retainer and retighten until it stops. Repeat this procedure several times. Tighten the RH retainer 1-3/4 notches further. This sets the preload. Finally, secure the retainer with its lock plate.

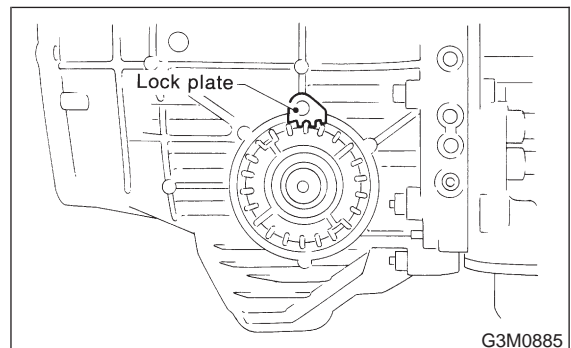

NOTE:

Turning the retainer by one tooth changes the backlash about 0.05 mm (0.0020 in).

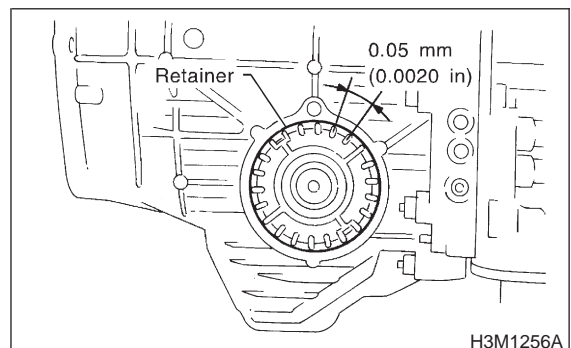

(7) Turn the drive pinion several rotations with ST1 and check to see if the backlash is within the standard value with ST2, ST3, ST4 and ST5.

NOTE:

After confirming that the backlash is correct, check the tooth contact.

- ST1 499787100 WRENCH
- ST2 498247001 MAGNET BASE
- ST3 498247100 DIAL GAUGE
- ST4 499757800 ADAPTER WRENCH
- ST5 498255400 PLATE

Backlash:

0.13 — 0.18 mm (0.0051 — 0.0071 in)



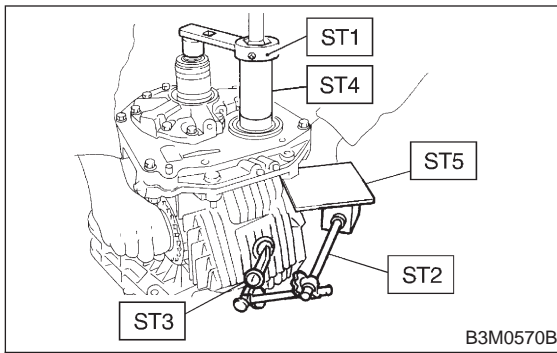



(8) Apply red lead evenly to the surfaces of three or four teeth of the crown gear. Rotate the drive pinion in the forward and reverse directions several times. Then remove the oil pump housing, and check the tooth contact pattern. If tooth contact is improper, readjust the backlash or shim thickness.



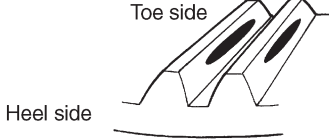

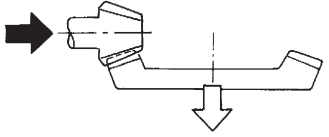
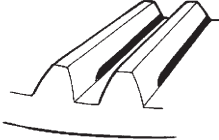
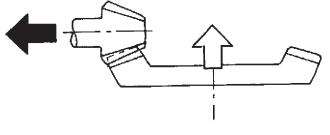
3-2 [W11C1]

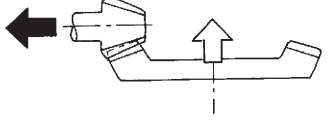
11. Overall Transmission

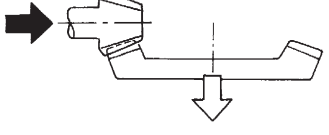
SERVICE PROCEDURE

Checking item	Contact pattern	Corrective action
<p>Tooth contact Tooth contact pattern is slightly shifted toward to under no-load rotation. [When loaded, contact pattern moves toward heel.]</p>	 <p style="text-align: center;">B3M0317A</p>	<p style="text-align: center;">—</p>
<p>Face contact Backlash is too large.</p>	<p>This may cause noise and chipping at tooth ends.</p>  <p style="text-align: center;">B3M0319</p>	<p>Increase thickness of drive pinion height adjusting shim in order to bring drive pinion close to crown gear.</p>  <p style="text-align: right;">B3M0323</p>
<p>Flank contact Backlash is too small.</p>	<p>This may cause noise and stepped wear on surfaces.</p>  <p style="text-align: center;">B3M0320</p>	<p>Reduce thickness of drive pinion height adjusting shim in order to move drive pinion away from crown gear.</p>  <p style="text-align: right;">B3M0324</p>
<p>Toe contact (Inside end contact) Contact areas is small.</p>	<p>This may cause chipping at toe.</p>  <p style="text-align: center;">B3M0321</p>	<p>Adjust as for flank contact.</p>  <p style="text-align: right;">B3M0324</p>
<p>Heel contact (Outside end contact) Contact area is small.</p>	<p>This may cause chipping at heel ends.</p>  <p style="text-align: center;">B3M0322</p>	<p>Adjust as for face contact.</p>  <p style="text-align: right;">B3M0323</p>

 : Adjusting direction of drive pinion
 : Adjusting direction of crown gear

(9) If tooth contact is correct, mark the retainer position and loosen it. After fitting the O-ring, screw in the retainer to the marked position. Then tighten the lock plate to the specified torque.

Tightening torque:

$25 \pm 2 \text{ N}\cdot\text{m}$ ($2.5 \pm 0.2 \text{ kg}\cdot\text{m}$, $18.1 \pm 1.4 \text{ ft}\cdot\text{lb}$)

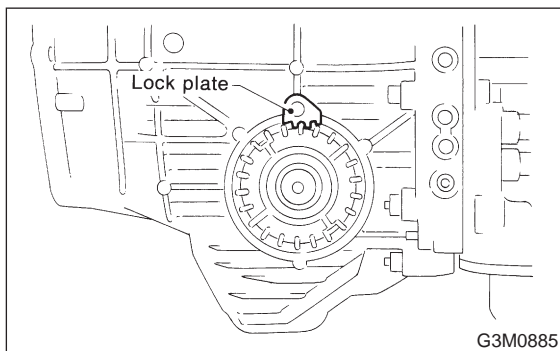

9) Install the seal pipe to the torque converter clutch case.

CAUTION:

Be sure to use a new seal pipe.

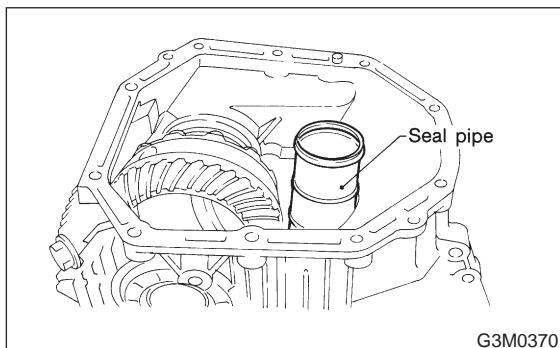

10) Install two oil seals to the oil seal retainer with ST.

CAUTION:

- Always discard old oil seals, and install new ones.
- Pay attention to the orientation of the oil seals.

ST 499247300 INSTALLER

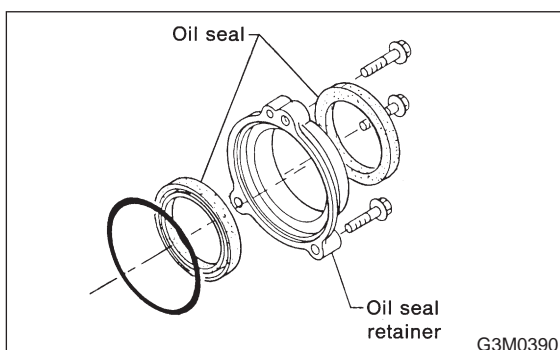

11) Attach the O-ring to the oil seal retainer with vaseline. Install the seal to the oil pump housing bore.

CAUTION:

Always discard old O-rings and install new ones.

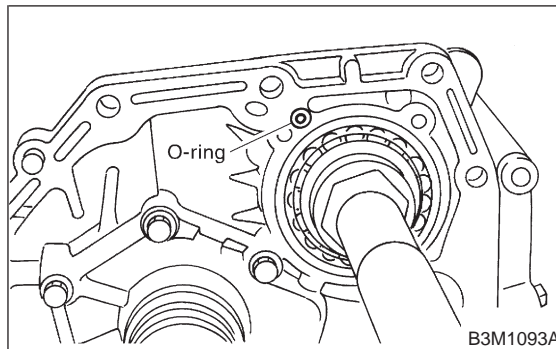

12) Install the oil seal retainer taking care not to damage the oil seal lips. Then secure with three bolts.

NOTE:

Make sure the O-ring is fitted correctly in position.

Tightening torque:

$7 \pm 1 \text{ N}\cdot\text{m}$ ($0.7 \pm 0.1 \text{ kg}\cdot\text{m}$, $5.1 \pm 0.7 \text{ ft}\cdot\text{lb}$)

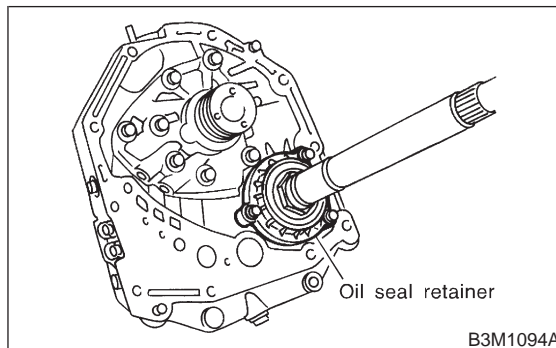

3-2 [W11C2]

11. Overall Transmission

SERVICE PROCEDURE

13) Apply vaseline to the groove on the oil pump cover, and install two (R) seal rings and two (H) seal rings.

NOTE:

- Fit the seal ring after compressing, and rub vaseline into the seal ring to avoid expansion.
- The "R" seal ring has a large diameter, while "H" has small diameter.

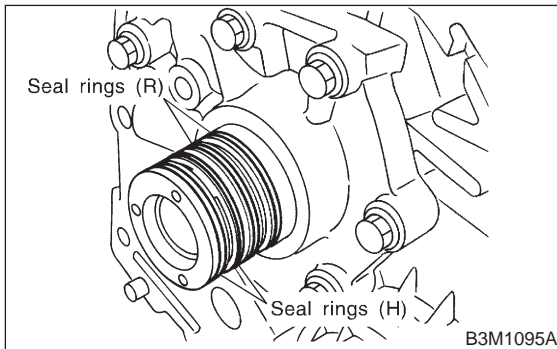

14) Install the rubber seal to the torque converter clutch case.

CAUTION:

Be careful not to lose the rubber seal.

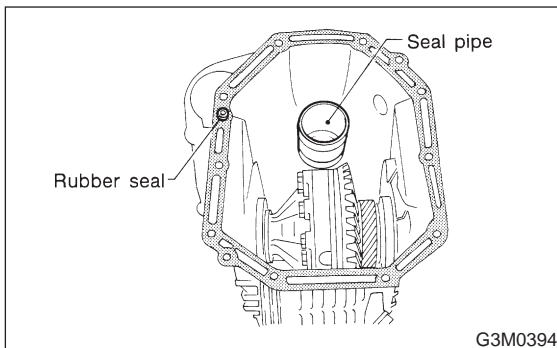

2. TRANSMISSION CASE SECTION

1) Using a plastic hammer, force-fit the oil seal.

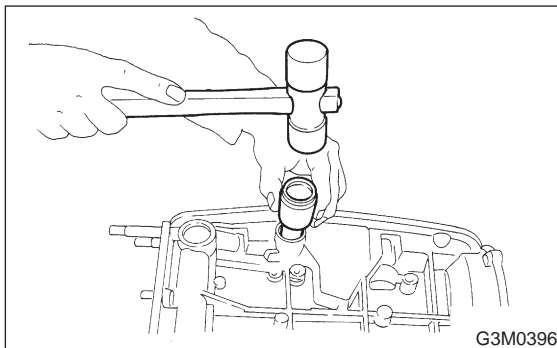

2) Install parking support to transmission case.

Tightening torque:

$25 \pm 2 \text{ N}\cdot\text{m}$ ($2.5 \pm 0.2 \text{ kg}\cdot\text{m}$, $18.1 \pm 1.4 \text{ ft}\cdot\text{lb}$)

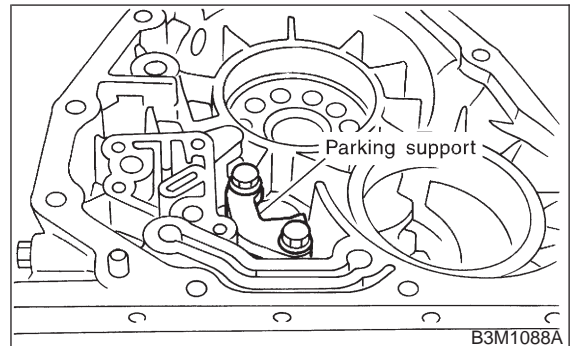

3) Install inhibitor switch to transmission case.

NOTE:

Temporary tighten inhibitor switch.

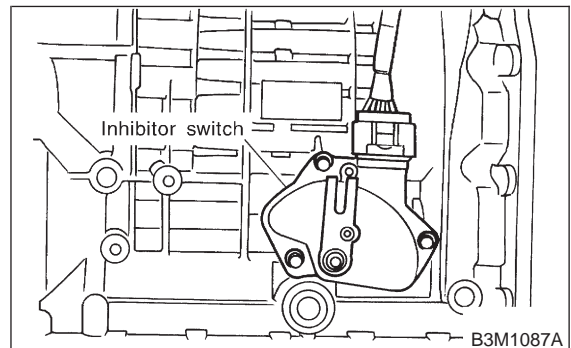

4) Install detention spring to transmission case.

Tightening torque:

$6 \pm 1 \text{ N}\cdot\text{m}$ ($0.6 \pm 0.1 \text{ kg}\cdot\text{m}$, $4.3 \pm 0.7 \text{ ft}\cdot\text{lb}$)

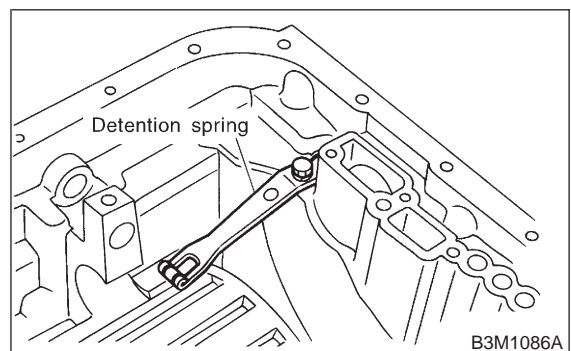

5) Insert range select lever, and tighten bolt.

Tightening torque:

6 ± 1 N·m (0.6 ± 0.1 kg·m, 4.3 ± 0.7 ft·lb)

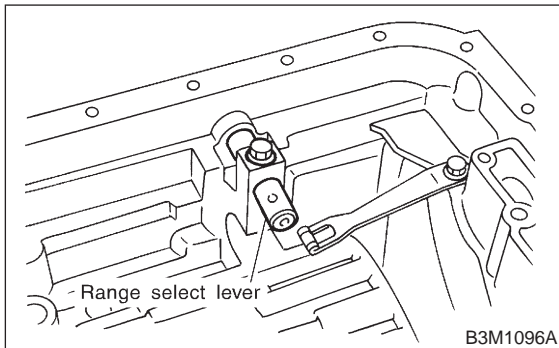

6) Insert manual lever and parking rod.

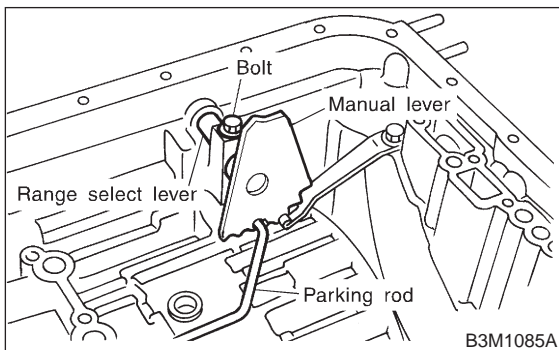

7) Insert spring pin to manual lever.

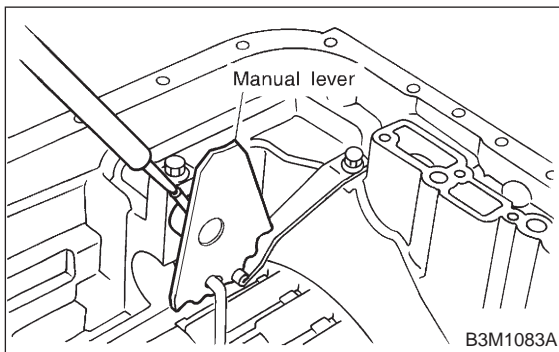

8) Install the low and reverse piston.

CAUTION:

- Be careful not to tilt the piston when installing.
- Be careful not to damage the lip seal.

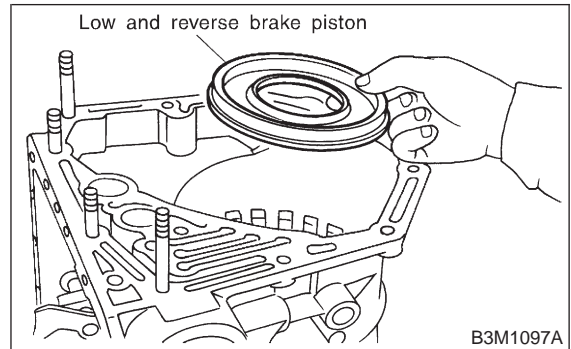

9) Install return spring.

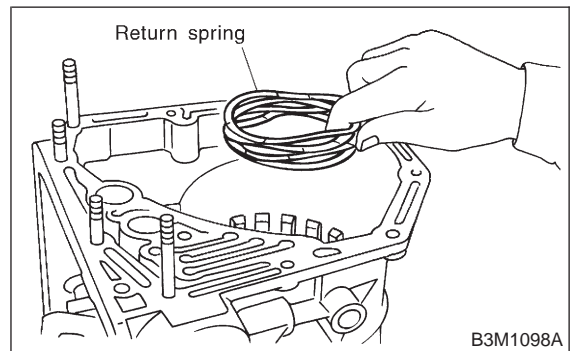

10) Install spring retainer.

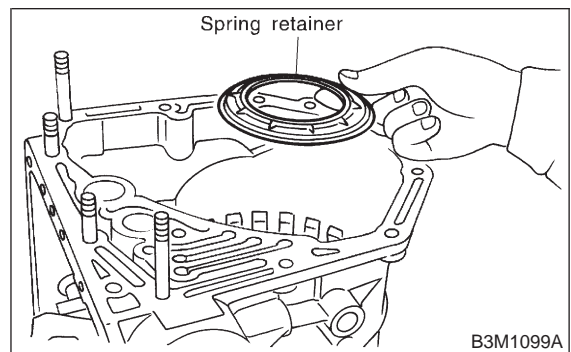

11) Install the one-way clutch inner race.

3-2 [W11C2]

11. Overall Transmission

SERVICE PROCEDURE

- (1) Using a press and ST1, install the needle bearing to the inner race.

ST1 398497701 INSTALLER

NOTE:

Use the following ST when removing.

ST 398527700 PULLER ASSY

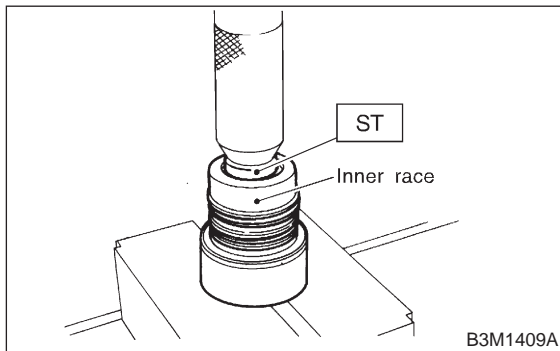

- (2) Install two seal rings to one-way clutch inner race.

NOTE:

Apply vaseline to the groove of the inner race and to the seal ring after installation, so that the seal ring will not expand.

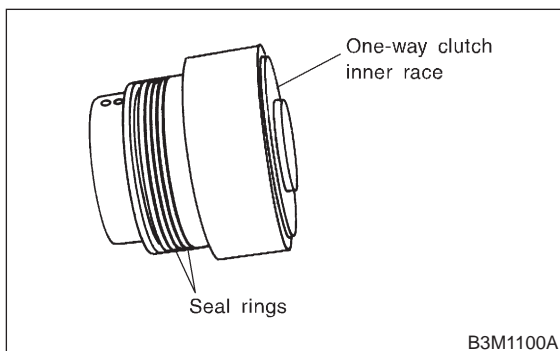

- (3) Tighten eight socket head bolts from the rear side of the transmission case.

Tightening torque:

$25 \pm 2 \text{ N}\cdot\text{m}$ ($2.5 \pm 0.2 \text{ kg}\cdot\text{m}$, $18.1 \pm 1.4 \text{ ft}\cdot\text{lb}$)

CAUTION:

Be sure to tighten evenly.

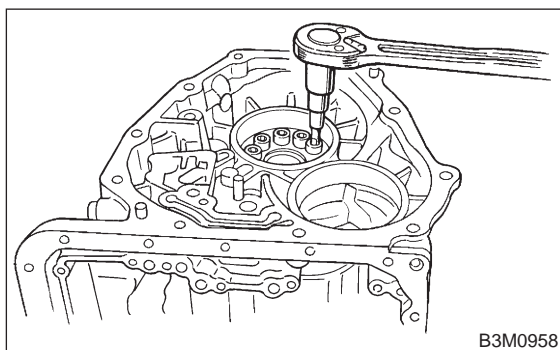

- (4) Install thrust needle bearing.

NOTE:

Place transmission case with the front facing up.

- 12) Installation of the low & reverse brake:

- (1) Install dish plate, driven plates, drive plates, and a retaining plate, and secure with a snap ring.

NOTE:

Pay attention to the orientation of the dish plate.

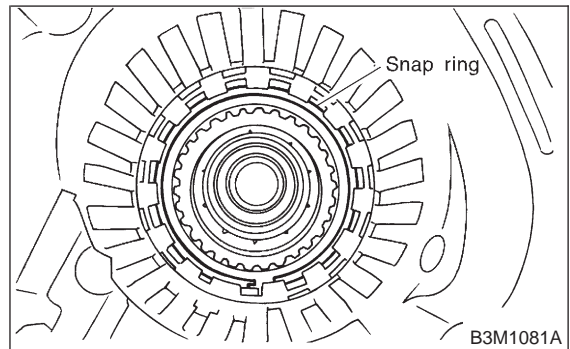

- (2) Apply compressed air intermittently to check for operation.

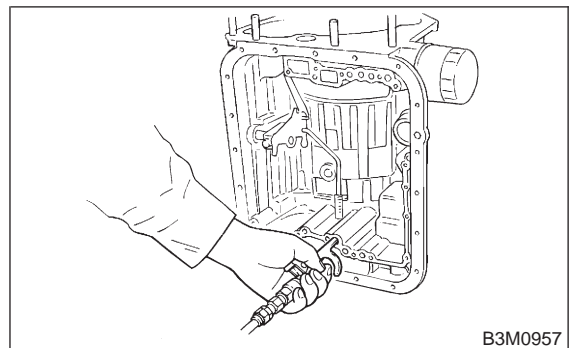

- (3) Check the clearance. (Selection of retaining plate)

NOTE:

Before measuring clearance, place the same thickness of shim on both sides to prevent retaining plate from tilting.

Standard value:

$0.7 - 1.2 \text{ mm}$ ($0.028 - 0.047 \text{ in}$)

Allowable limit:

2.2 mm (0.087 in)

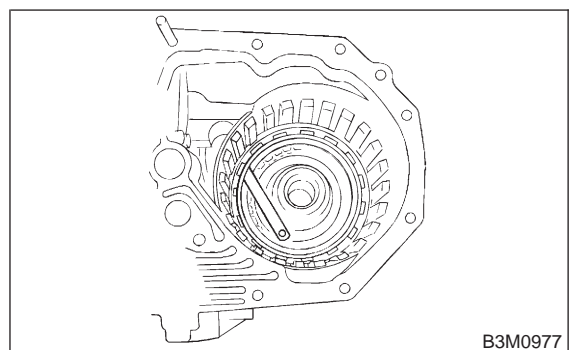

Available retaining plates	
Part No.	Thickness mm (in)
31667AA320	4.2 (0.165)
31667AA330	4.5 (0.177)
31667AA340	4.8 (0.189)
31667AA350	5.1 (0.201)
31667AA360	5.4 (0.213)
31667AA370	5.7 (0.224)
31667AA380	6.0 (0.236)

13) Install leaf spring of low and reverse brake.

CAUTION:

Pay attention to the direction and position of leaf spring during installation.

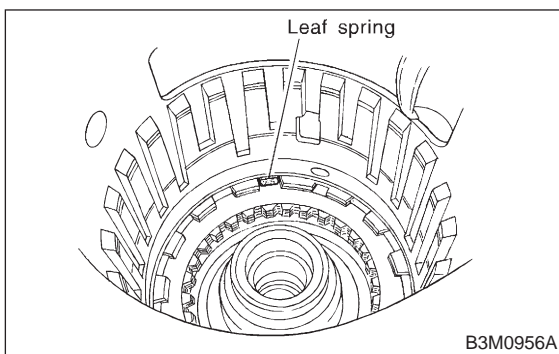

14) Install O-ring to 2-4 brake piston.

CAUTION:

- If O-ring breaks or damage is noted, replace with new O-ring.
- Apply a coat of vaseline to inner side of O-ring before installation.

15) Install 2-4 brake piston to 2-4 brake piston retainer.

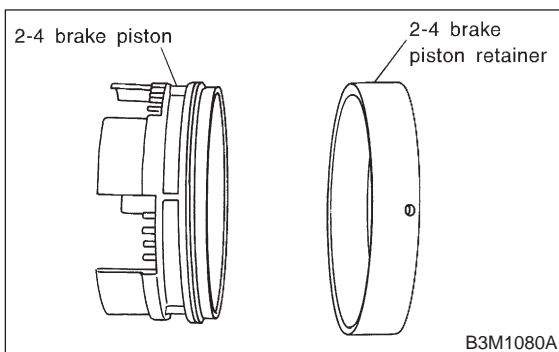

16) Install 2-4 brake piston and retainer to transmission case.

CAUTION:

Align the hole in the 2-4 brake seal of transmission case with the hole in 2-4 brake piston retainer during installation.

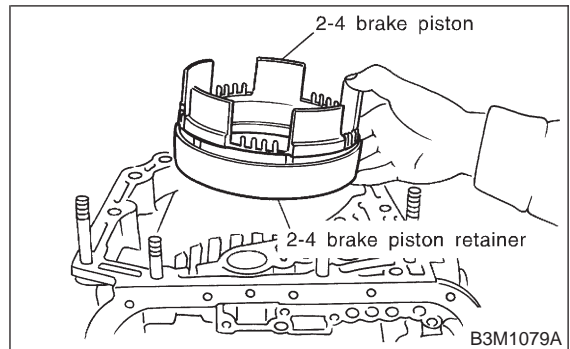

17) Install 2-4 brake piston return spring to transmission case.

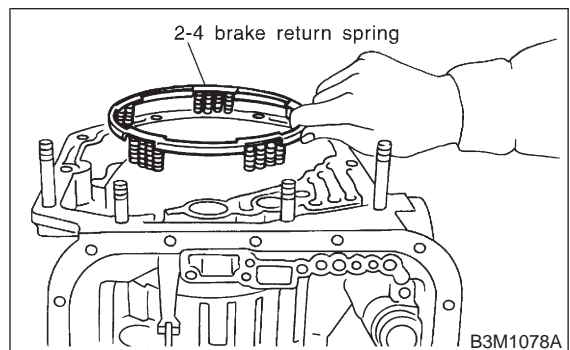

18) Position snap ring in transmission. Using ST, press the snap ring into place.
ST 498677100 COMPRESSOR

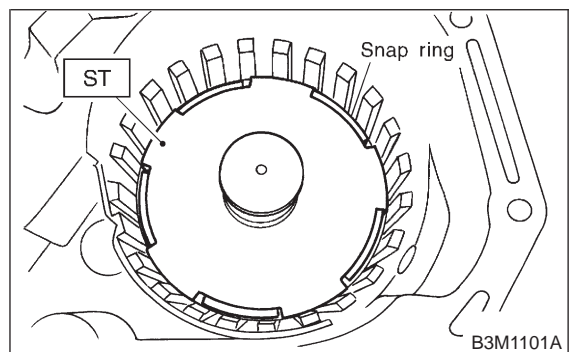

3-2 [W11C2]

11. Overall Transmission

SERVICE PROCEDURE

19) Install planetary gear and low clutch assembly to transmission case.
Install carefully while rotating the low clutch and planetary gear assembly slowly paying special attention not to damage the seal ring.

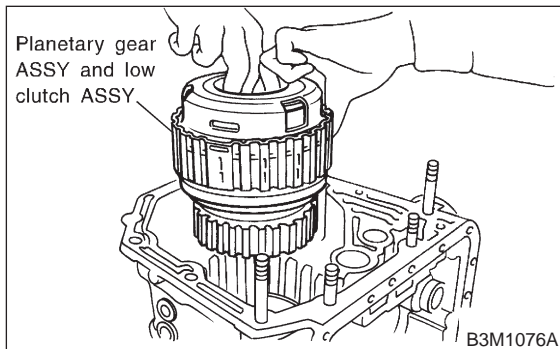

20) Installation of the 2-4 brake:

(1) Install pressure plate, drive plate, driven plate, retaining plate and snap ring.

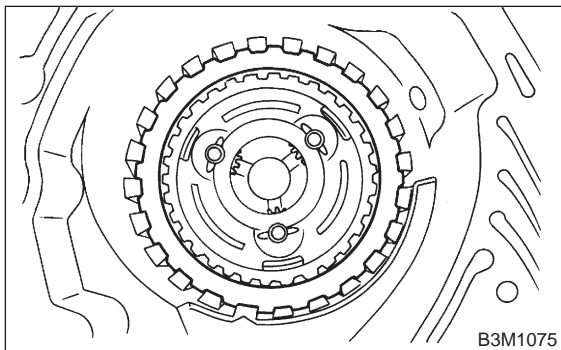

(2) Install 2-4 brake oil seal to transmission case.

NOTE:

Be sure to use a new one.

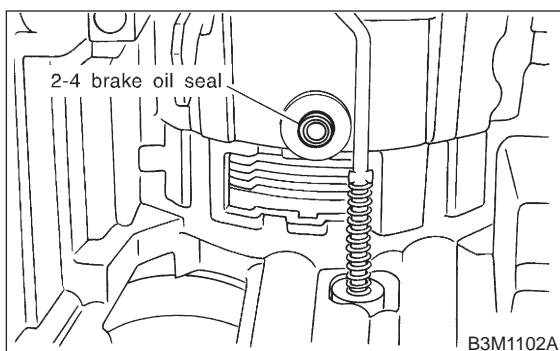

(3) After all 2-4 brake component parts have been installed, blow in air intermittently and confirm the operation of the brake.

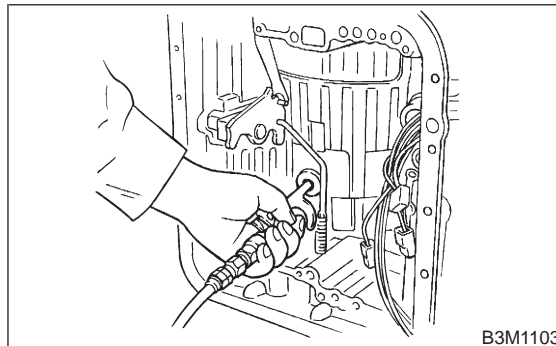

(4) Measure the clearance between the retaining plate and the snap ring.

NOTE:

Select a retaining plate with a suitable value from the following table, so that the clearance becomes the standard value.

Standard value:

0.8 — 1.2 mm (0.031 — 0.047 in)

Allowable limit:

1.5 mm (0.059 in)

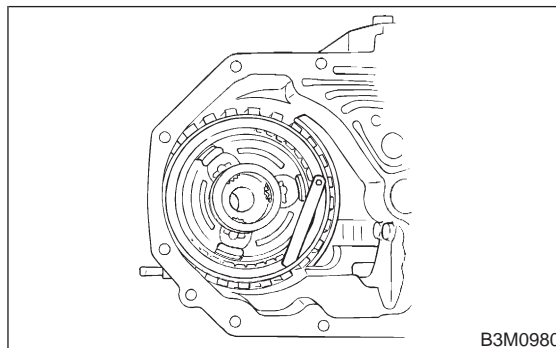

Available retaining plates	
Part No.	Thickness mm (in)
31567AA610	5.6 (0.220)
31567AA620	5.8 (0.228)
31567AA630	6.0 (0.236)
31567AA640	6.2 (0.244)
31567AA650	6.4 (0.252)
31567AA660	6.6 (0.260)

21) Install leaf spring of 2-4 brake.

NOTE:

Be careful not to mistake the location of the leaf spring to be inserted.

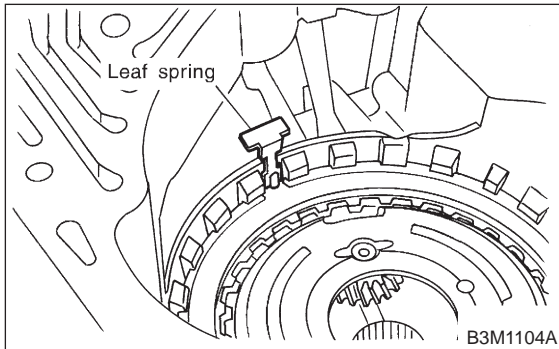

22) Install thrust needle bearing.

CAUTION:

Install thrust needle bearing in the correct direction. <Ref. to 3-2 [S1C0].>

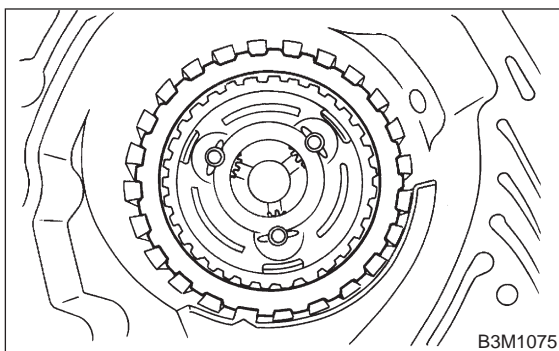

23) Install front sun gear and thrust needle bearing.

CAUTION:

Install thrust needle bearing in the correct direction. <Ref. to 3-2 [S1C0].>

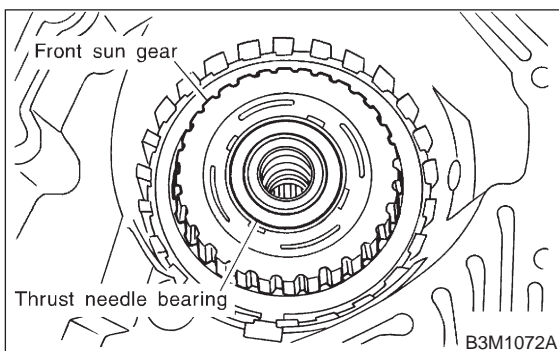

24) Install the high clutch hub and thrust needle bearing.

Attach the thrust needle bearing to the hub with vaseline and install the hub by correctly engaging the splines of the front planetary carrier.

CAUTION:

Install thrust needle bearing in the correct direction. <Ref. to 3-2 [S1C0].>

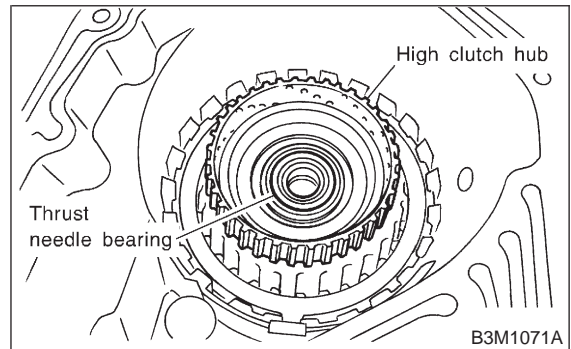

25) Install the high clutch assembly.

NOTE:

Correctly engage the high clutch hub and clutch splines.

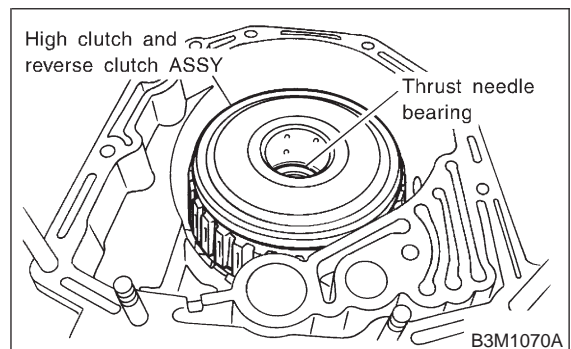

26) Adjustment of total end play:

(1) Using ST, measure the distance from the transmission case mating surface to the recessed portion of the high clutch drum "L".

ST 398643600 GAUGE

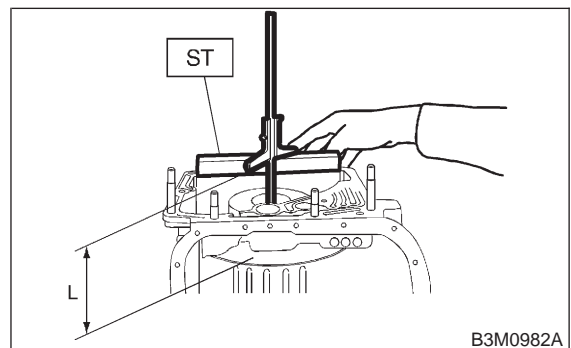

(2) Using ST, measure the distance from the oil pump housing mating surface to the top surface of the oil pump cover with thrust needle bearing.
ST 398643600 GAUGE

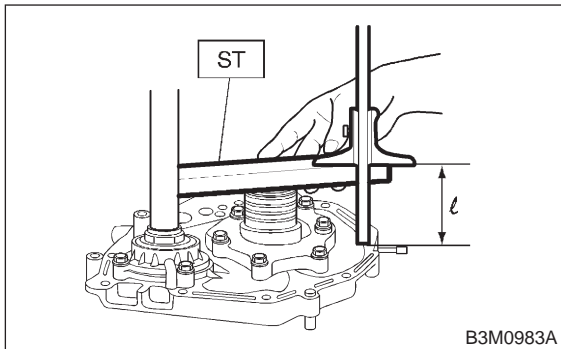

(3) Calculation of total end play
Select suitable bearing race from among those listed in this table so that clearance C is in the 0.25 — 0.55 mm (0.0098 — 0.0217 in) range.
 $C = (L + G) - \ell$

C	Clearance between concave portion of high clutch and end of clutch drum support
L	Length from case mating surface to concave portion of high clutch
G	Gasket thickness (0.28 mm, 0.0110 in)
ℓ	Height from housing mating surface to upper surface of clutch drum support

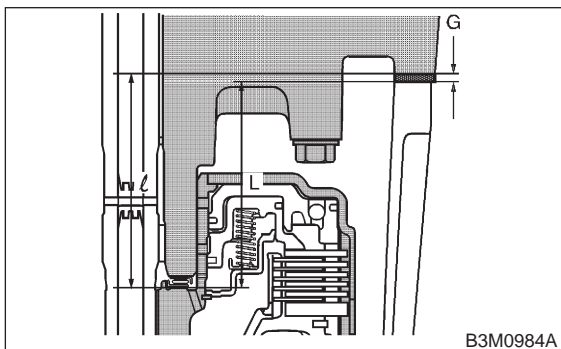

Thrust needle bearing	
Part No.	Thickness mm (in)
806528050	4.1 (0.161)
806528060	4.3 (0.169)
806528070	4.5 (0.177)
806528080	4.7 (0.185)
806528090	4.9 (0.193)
806528100	5.1 (0.201)

27) Install the oil pump housing assembly.
(1) After completing end play adjustment, insert the bearing race in the recess of the high clutch. Attach the thrust needle bearing to the oil pump cover with vaseline.

(2) After correctly installing the gasket to the case mating surface, carefully install the oil pump housing assembly. Be careful to avoid hitting the drive pinion against the inside of the case.

CAUTION:

- Be careful not to damage the seal ring.
- Be sure to use a new gasket.

(3) Install both parts with dowel pins aligned. Make sure no clearance exists at the mating surface.

NOTE:

Any clearance suggests a damaged seal ring.

(4) Secure the housing with two nuts.

Tightening torque:

T: 41±3 N·m (4.2±0.3 kg-m, 30.4±2.2 ft-lb)

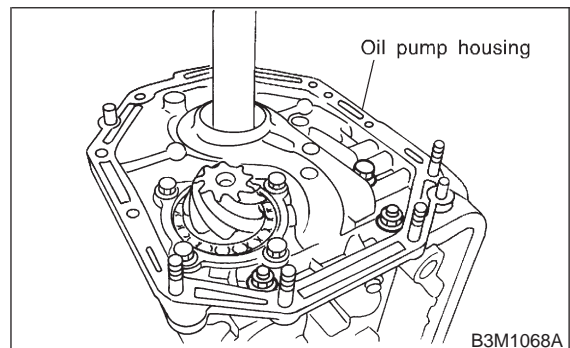

3. TORQUE CONVERTER CLUTCH CASE AND TRANSMISSION CASE

1) Apply proper amount of liquid gasket (THREE BOND Part No. 1215) to the entire torque converter clutch case mating surface.

NOTE:

Make sure that the rubber seal and seal pipe are fitted in position.

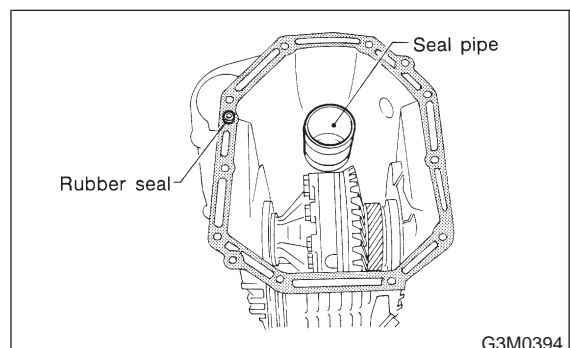

2) Install the torque converter clutch case assembly to the transmission case assembly, and secure with six bolts and four nuts.

CAUTION:

When installing, be careful not to damage the torque converter clutch case bushing and oil seal.

Tightening torque:

41 ± 3 N·m (4.2 ± 0.3 kg·m, 30.4 ± 2.2 ft·lb)

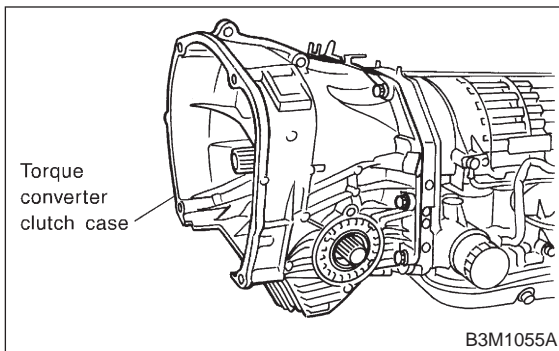

4. CONTROL VALVE AND OIL PAN

1) Install and route the transmission harness.

CAUTION:

Be careful not to damage the harness.

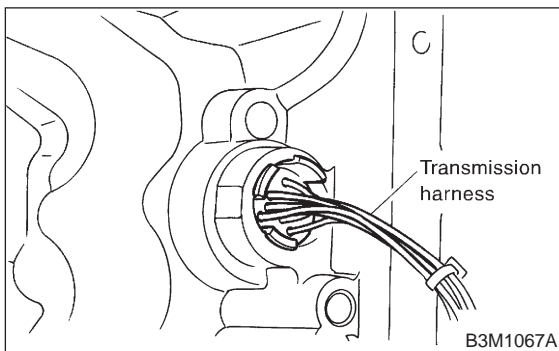

2) Install the control valve assembly.

(1) Set the select lever in range "N".

(2) Install the control valve by engaging the manual valve and manual lever, then tighten the 17 bolts.

CAUTION:

Tighten the control valve mounting bolts evenly.

Tightening torque:

8 ± 1 N·m (0.8 ± 0.1 kg·m, 5.8 ± 0.7 ft·lb)

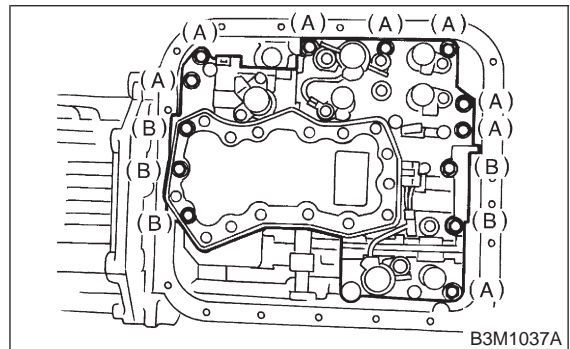

- (A) Short bolts
- (B) Long bolts

3) Connect all connectors.

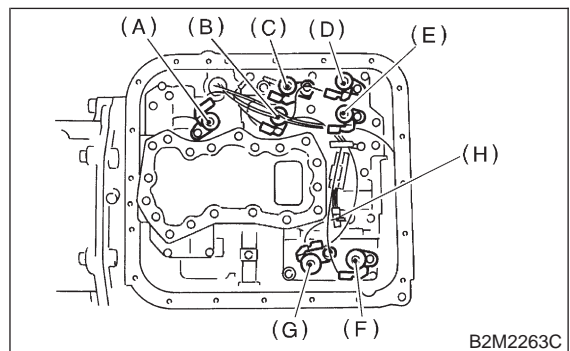

- (A) Lock-up duty solenoid (Blue)
- (B) Low clutch timing solenoid (Gray)
- (C) Line pressure duty solenoid (Red)
- (D) Shift solenoid 2 (Yellow)
- (E) Shift solenoid 1 (Green)
- (F) 2-4 brake timing solenoid (Black)
- (G) 2-4 brake duty solenoid (Red)
- (H) ATF temperature sensor

4) Install the oil pan.

(1) Attach the magnet at the specified position.

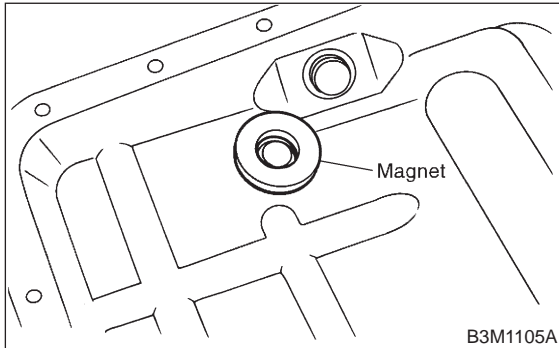

(2) Apply proper amount of liquid gasket (THREE BOND Part No. 1217B) to the entire oil pan mating surface.

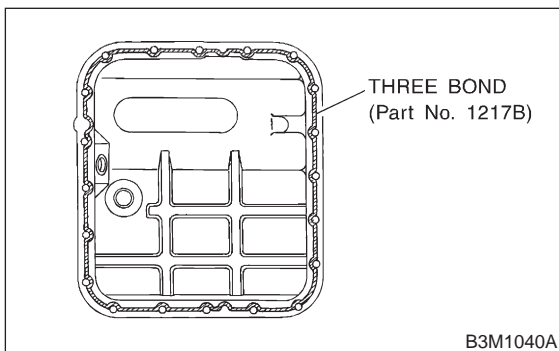

(3) Install the oil pan to the transmission case assembly, and secure with 20 bolts.

NOTE:
Tighten the bolts evenly.

Tightening torque:
 $4.9 \pm 0.5 \text{ N}\cdot\text{m}$ ($0.50 \pm 0.05 \text{ kg}\cdot\text{m}$, $3.6 \pm 0.4 \text{ ft}\cdot\text{lb}$)

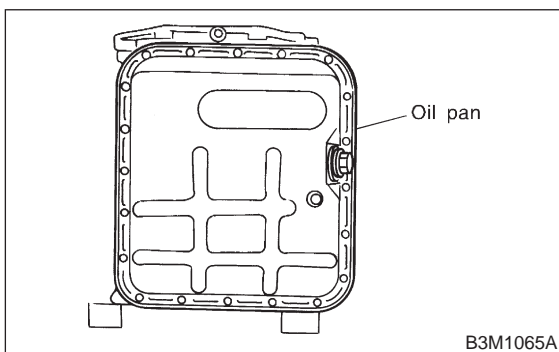

5) Install torque converter turbine speed sensor and vehicle speed sensor 2 (front).

Tightening torque:
 $7 \pm 1 \text{ N}\cdot\text{m}$ ($0.7 \pm 0.1 \text{ kg}\cdot\text{m}$, $5.1 \pm 0.7 \text{ ft}\cdot\text{lb}$)

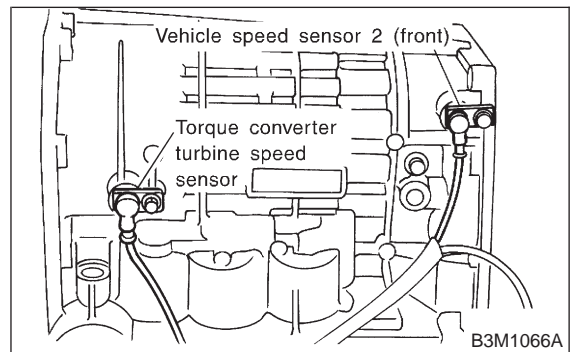

5. EXTENSION SECTION

NOTE:

When installing new oil seal into extension case, press it with ST.

ST 498057300 INSTALLER

1) Install the transfer pipe to extension case.

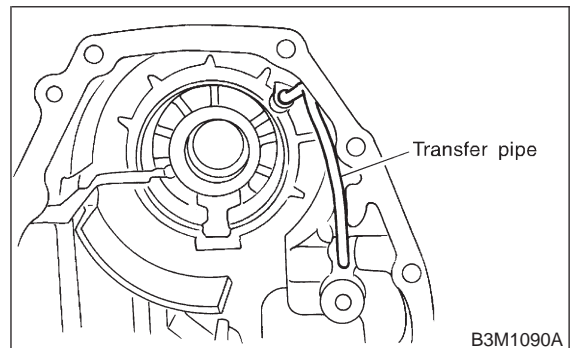

2) Install the transfer clutch assembly to the case.

CAUTION:
Be careful not to damage the seal rings.

NOTE:

Insert the clutch assembly fully into position until the bearing shoulder bottoms.

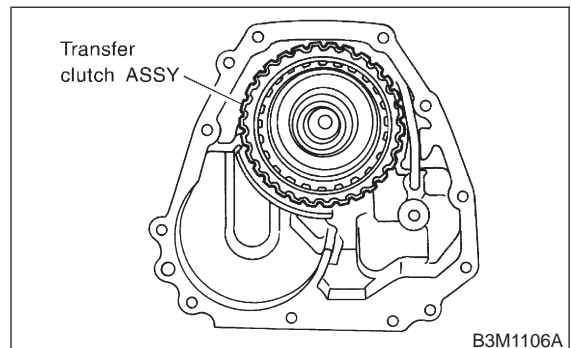

6. CONNECTION OF EACH SECTION

1) Install the parking pawl, shaft and return spring.

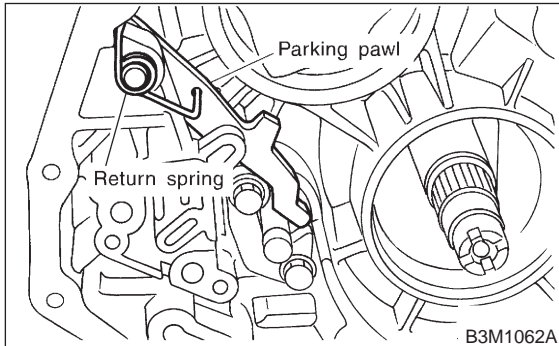

2) Install inlet filter to transmission case.

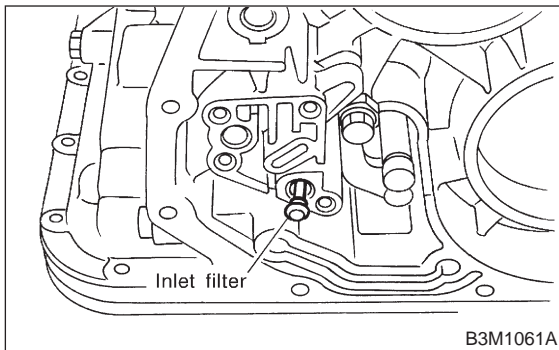

3) Install transfer valve plate, valve body and duty solenoid C (transfer) to transmission case.

CAUTION:

- Be sure to install transfer seal lip to transfer control valve body.
- If transfer seal lip is damaged, replace seal with new one.

Tightening torque:

$8 \pm 1 \text{ N}\cdot\text{m}$ ($0.8 \pm 0.1 \text{ kg}\cdot\text{m}$, $5.8 \pm 0.7 \text{ ft}\cdot\text{lb}$)

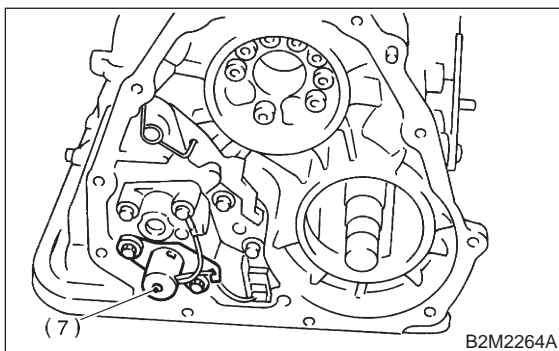

4) Connect connector to duty solenoid C (transfer).

5) Install the reduction drive gear assembly.

NOTE:

Insert it fully into position until the bearing shoulder bottoms.

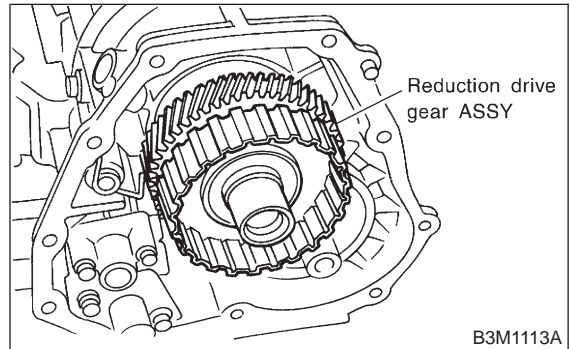

6) Using a plastic hammer, install reduction driven gear assembly, and tighten drive pinion lock nut.

NOTE:

- Be sure to use a new lock nut and a washer.
- Set the select lever in the "P" range.
- After tightening, stake the lock nut securely.

Tightening torque:

$98 \pm 5 \text{ N}\cdot\text{m}$ ($10.0 \pm 0.5 \text{ kg}\cdot\text{m}$, $72.3 \pm 3.6 \text{ ft}\cdot\text{lb}$)

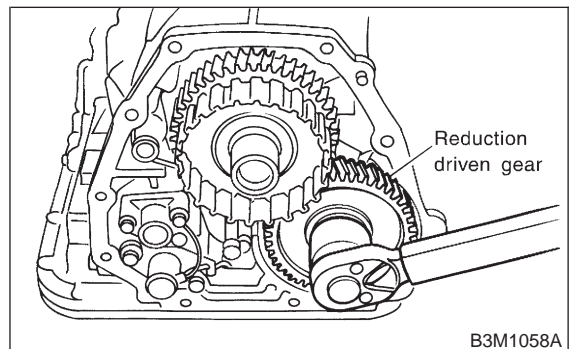

7) Measurement and adjustment of extension end play

(1) Measure distance L from end of extension case and rear drive shaft with ST.

ST 398643600 GAUGE

L = Measured value - 15 mm

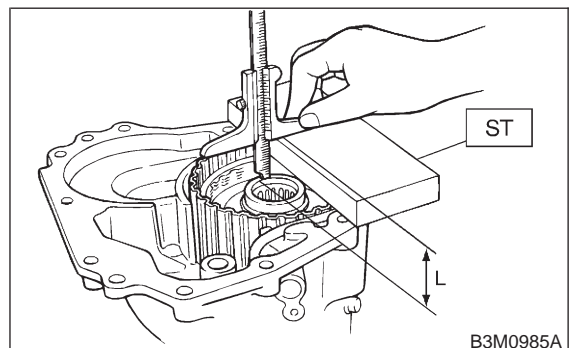

3-2 [W11C6]

11. Overall Transmission

SERVICE PROCEDURE

(2) Measure the distance “ ℓ ” from the transmission case mating surface to the reduction drive gear end surface with ST1 and ST2.

ℓ = Measured value – 50 mm

ST1 398643600 GAUGE

ST2 499577000 GAUGE

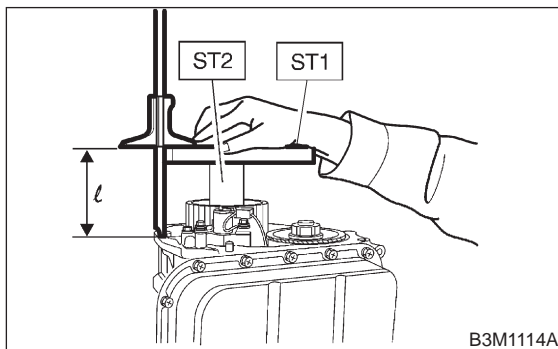

(3) Calculation equation:

NOTE:

Add 0.05 mm (0.0020 in) and 0.20 mm (0.0079 in) thick shims to area “T”. Calculate formula 2 to determine “H”. The calculated “H” refers to the shim thickness range. Select shims of suitable thicknesses within the calculated “H” range.

$$T = (L + G) - \ell - H$$

T : Shim clearance

L : Distance from end of extension case to end of rear drive shaft

G: Gasket thickness (0.45 mm, 0.0177 in)

ℓ : Height from end of transmission case to end of reduction drive gear

H : Thrust needle bearing thickness

0.05 — 0.25 mm (0.0020 — 0.0098 in)

Thrust needle bearing	
Part No.	Thickness mm (in)
806536020	3.8 (0.150)
806535030	4.0 (0.157)
806535040	4.2 (0.165)
806535050	4.4 (0.173)
806535060	4.6 (0.181)
806535070	4.8 (0.189)
806535090	5.0 (0.197)

8) Installation of extension case and transmission case

(1) Attach the selected thrust needle bearing to the end surface of reduction drive gear with vaseline.

CAUTION:

Install thrust needle bearing in the correct direction. <Ref. to 3-2 [S1C0].>

(2) Install the extension case to the transmission case.

CAUTION:

Be sure to use a new gasket.

(3) Tighten bolts to secure the case.

Tightening torque:

25 ± 2 N·m (2.5 ± 0.2 kg·m, 18.1 ± 1.4 ft·lb)

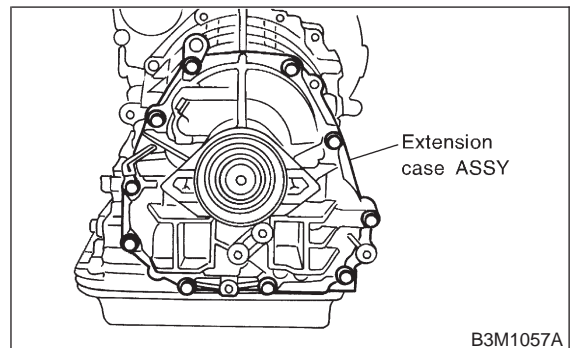

9) Install the vehicle speed sensor 1 (rear).

Tightening torque:

7 ± 1 N·m (0.7 ± 0.1 kg·m, 5.1 ± 0.7 ft·lb)

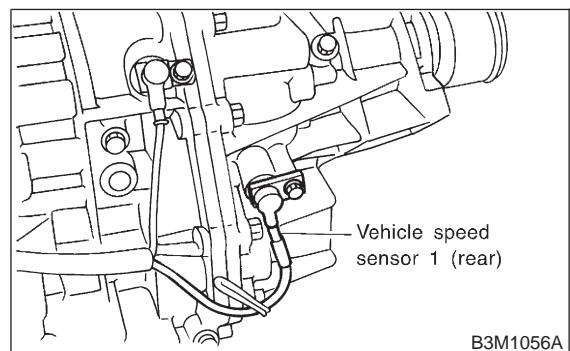

7. EXTERNAL PARTS

1) Using ST, install ATF filter to transmission case. Calculate ATF filter torque specifications using the following formula.

$$T_2 = L_2 / (L_1 + L_2) \times T_1$$

T₁: 14±2 N·m (1.4±0.2 kg·m, 10.1±1.4 ft·lb)

[Required torque setting]

T₂: Tightening torque

L₁: ST length 0.078 m (3.07 in)

L₂: Torque wrench length

CAUTION:

Align ST with torque wrench while tightening AFT filter.

ST 498545400 OIL FILTER WRENCH

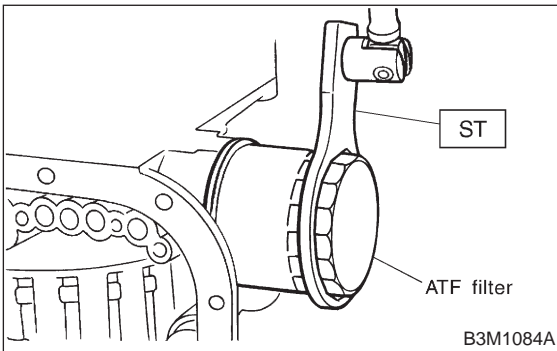

2) Adjustment of inhibitor switch

(1) With the select lever set to "N" adjust the inhibitor switch so that the hole of range select lever is aligned with the inhibitor switch hole with ST.

NOTE:

Ensure that gauge moves properly.

ST 499267300 STOPPER PIN

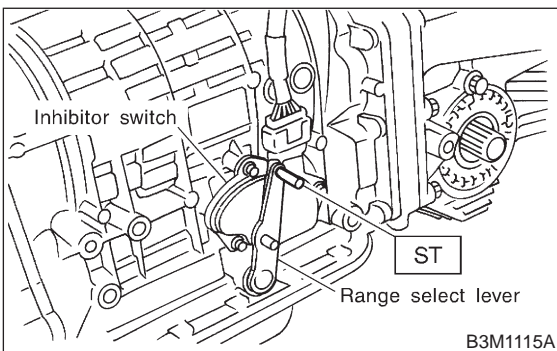

(2) With hole aligned, tighten three bolts to secure the inhibitor switch.

Tightening torque:

3.4±0.5 N·m (0.35±0.05 kg·m, 2.5±0.4 ft·lb)

3) Install air breather hose.

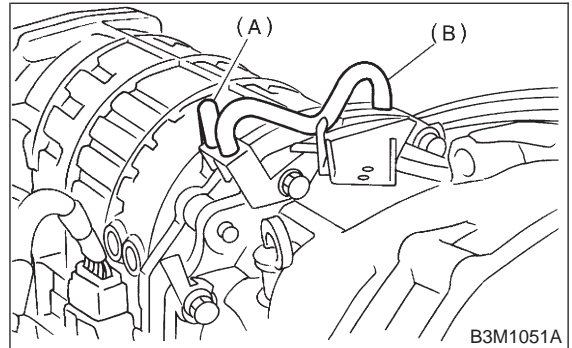

(A) Air breather hose (Transmission case)

(B) Air breather hose (Oil pump housing)

4) Clip the following cords and harness.

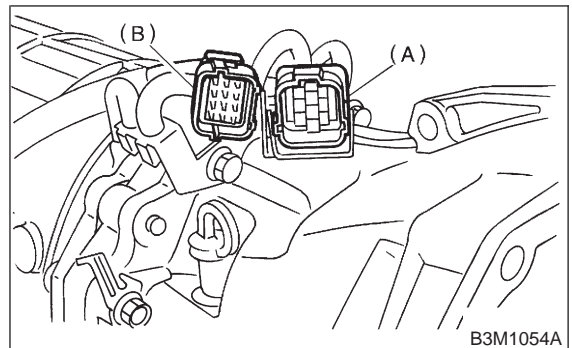

(A) Transmission harness

(B) Inhibitor switch harness

5) Install the oil cooler outlet pipe.

CAUTION:

Be sure to use a new aluminum washer.

Tightening torque:

34±3 N·m (3.5±0.3 kg·m, 25.3±2.2 ft·lb)

6) Install the oil cooler inlet pipe.

CAUTION:

Be sure to use a new aluminum washer.

Tightening torque:

25±2 N·m (2.5±0.2 kg·m, 18.1±1.4 ft·lb)

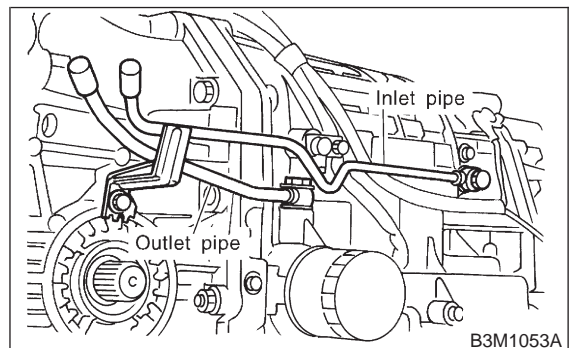

3-2 [W11C7]

11. Overall Transmission

SERVICE PROCEDURE

7) Install the oil charge pipe.

CAUTION:

Be careful not to damage the O-ring.

Tightening torque:

$41 \pm 3 \text{ N}\cdot\text{m}$ ($4.2 \pm 0.3 \text{ kg}\cdot\text{m}$, $30.4 \pm 2.2 \text{ ft}\cdot\text{lb}$)

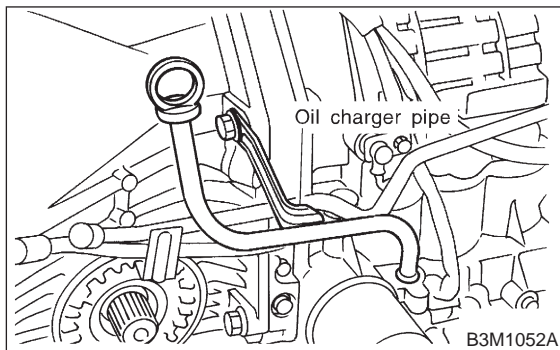

8) Install the pitching stopper bracket.

Tightening torque:

$41 \pm 3 \text{ N}\cdot\text{m}$ ($4.2 \pm 0.3 \text{ kg}\cdot\text{m}$, $30.4 \pm 2.2 \text{ ft}\cdot\text{lb}$)

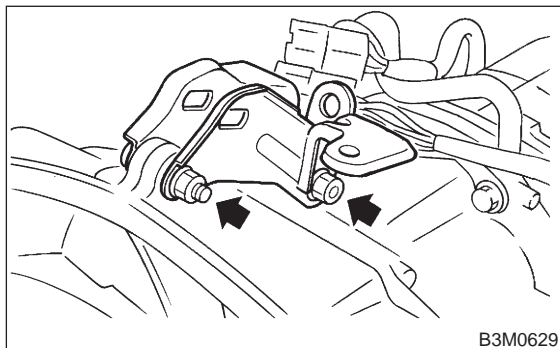

9) Tighten the drain plugs.

Tightening torque:

Diff.

$44 \pm 3 \text{ N}\cdot\text{m}$ ($4.5 \pm 0.3 \text{ kg}\cdot\text{m}$, $32.5 \pm 2.2 \text{ ft}\cdot\text{lb}$)

ATF

$25 \pm 2 \text{ N}\cdot\text{m}$ ($2.5 \pm 0.2 \text{ kg}\cdot\text{m}$, $18.1 \pm 1.4 \text{ ft}\cdot\text{lb}$)

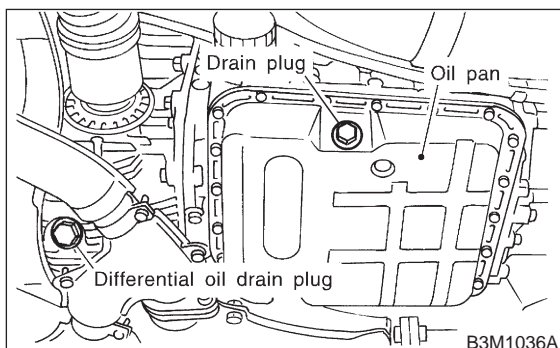

10) Insert the input shaft while turning lightly by hand.

CAUTION:

Be careful not to damage the bushing.

Normal protrusion A:

$50 - 55 \text{ mm}$ ($1.97 - 2.17 \text{ in}$)

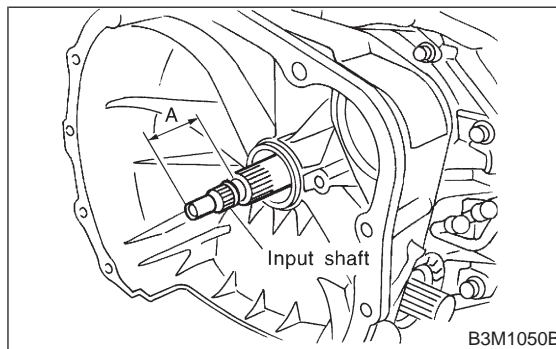

11) Install the torque converter clutch assembly.

(1) Install the oil pump shaft to the torque converter clutch.

NOTE:

Make sure the clip fits securely in its groove.

(2) Holding the torque converter clutch assembly by hand, carefully install it to the torque converter clutch case. Be careful not to damage the bushing. Also avoid undue contact between the oil pump shaft bushing and stator shaft portion of the oil pump cover.

(3) Rotate the shaft lightly by hand to engage the splines securely.

Dimension A:

2200 cc ; $-1.3 \text{ to } -1.1 \text{ mm}$ ($-0.051 \text{ to } -0.043 \text{ in}$)

2500 cc ; $2.7 - 2.9 \text{ mm}$ ($0.106 - 0.114 \text{ in}$)

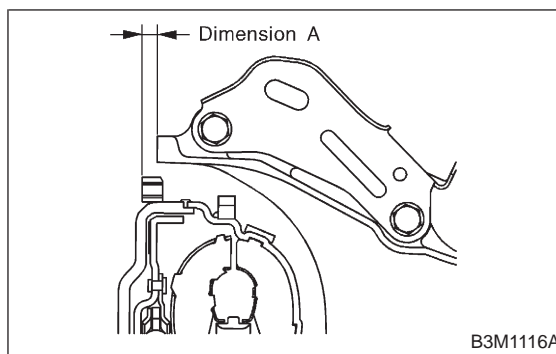

12) Fill ATF and differential gear oil.

NOTE:

After filling oil, insert the oil level gauge into the oil inlet.

Differential gear oil capacity:

1.1 — 1.3 ℓ (1.2 — 1.4 US qt, 1.0 — 1.1 Imp qt)

Automatic transmission fluid capacity:

2200 cc; 8.4 — 8.7 ℓ (8.9 — 9.2 US qt, 7.4 — 7.7 Imp qt)

2500 cc; 9.3 — 9.6 ℓ (9.8 — 10.1 US qt, 8.2 — 8.4 Imp qt)

Recommended fluid:

Dexron II or Dexron III type automatic transmission

12. Reduction Drive Gear Assembly

A: DISASSEMBLY

1) Take out the seal rings.

CAUTION:

Be careful not to damage the seal rings.

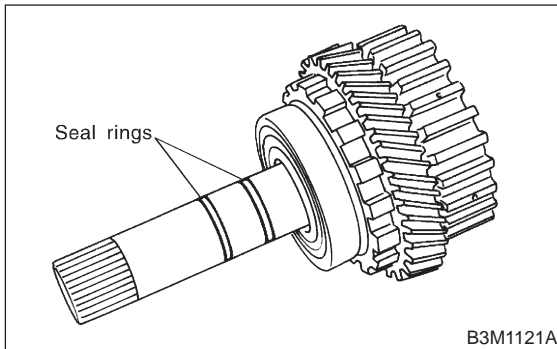

3) Attach two seal rings.

NOTE:

To make subsequent assembly easier, apply vaseline to the grooves of the shaft and to the exterior of the seal ring.

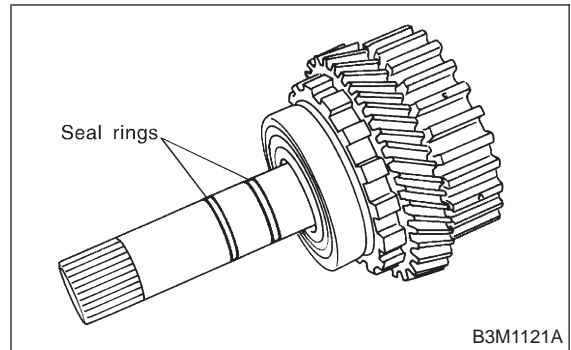

2) Using ST, remove the ball bearing.
ST 498077600 REMOVER

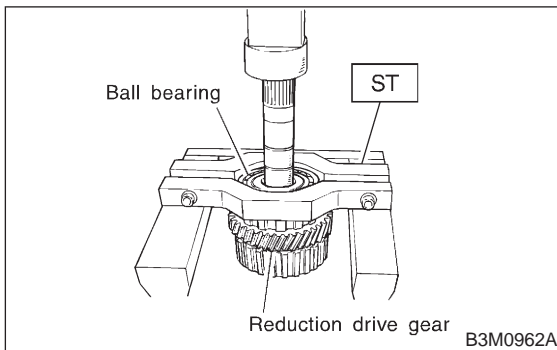

3) Using a press, remove the reduction drive gear.

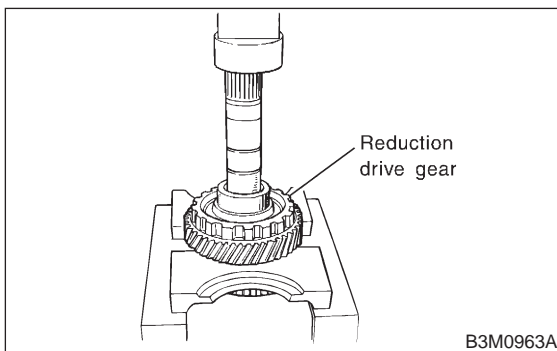

B: INSPECTION

Make sure that each component is free of harmful gouges, cuts, or dust.

C: ASSEMBLY

1) Press-fit the reduction drive gear to the shaft.
2) Press-fit the ball bearing to the reduction drive gear.

13. Reduction Driven Gear

A: REMOVAL

1) Remove snap ring from reduction driven gear.

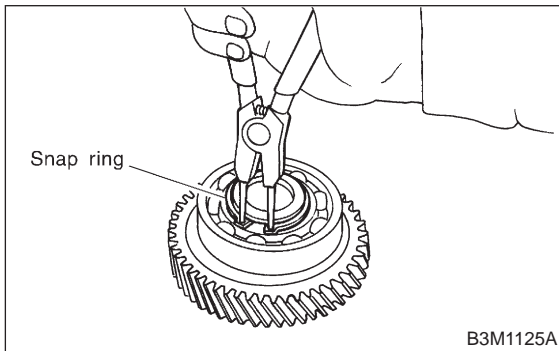

2) Install snap ring to reduction driven gear.

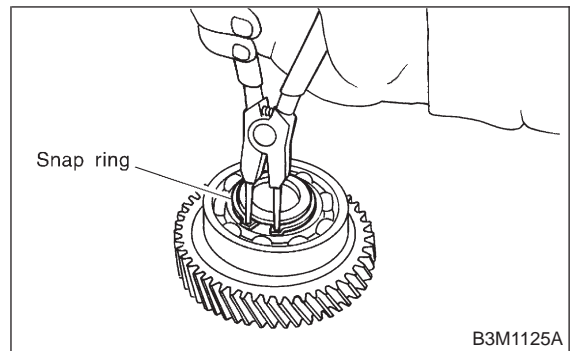

2) Using ST, remove ball bearing from reduction driven gear.

ST 498077600 REMOVER

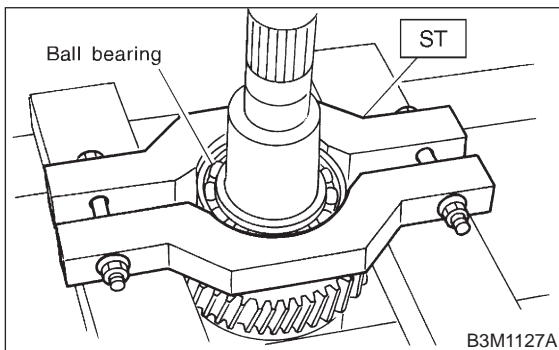

B: INSPECTION

Check ball bearing and gear for dents or damage.

C: ASSEMBLY

1) Using a press, install ball bearing to reduction driven gear.

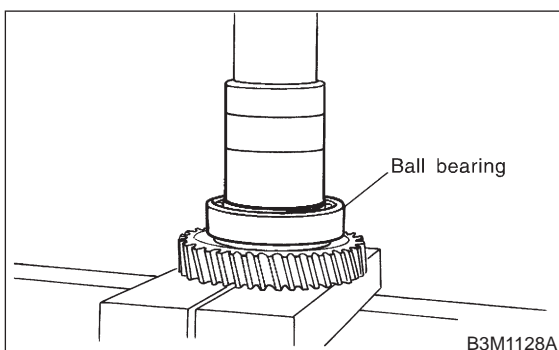

14. Control Valve Body

A: PRECAUTION

The control valve is composed of parts which are accurately machined to a high degree and should be handled carefully during disassembly and assembly. As these parts are similar in shape, they should be arranged in neat order on a table after disassembly so that they can be easily installed to their original positions. Spring loaded parts should

be also handled carefully, as springs may jump out of place when the parts are disassembled or removed. Extreme care should be taken so as not to drop valves on the floor. Before assembling, the parts and valves should be dipped in a container filled with the ATF. Make sure that the valves are clean and free from any foreign material before assembly. Torque specifications should also be observed.

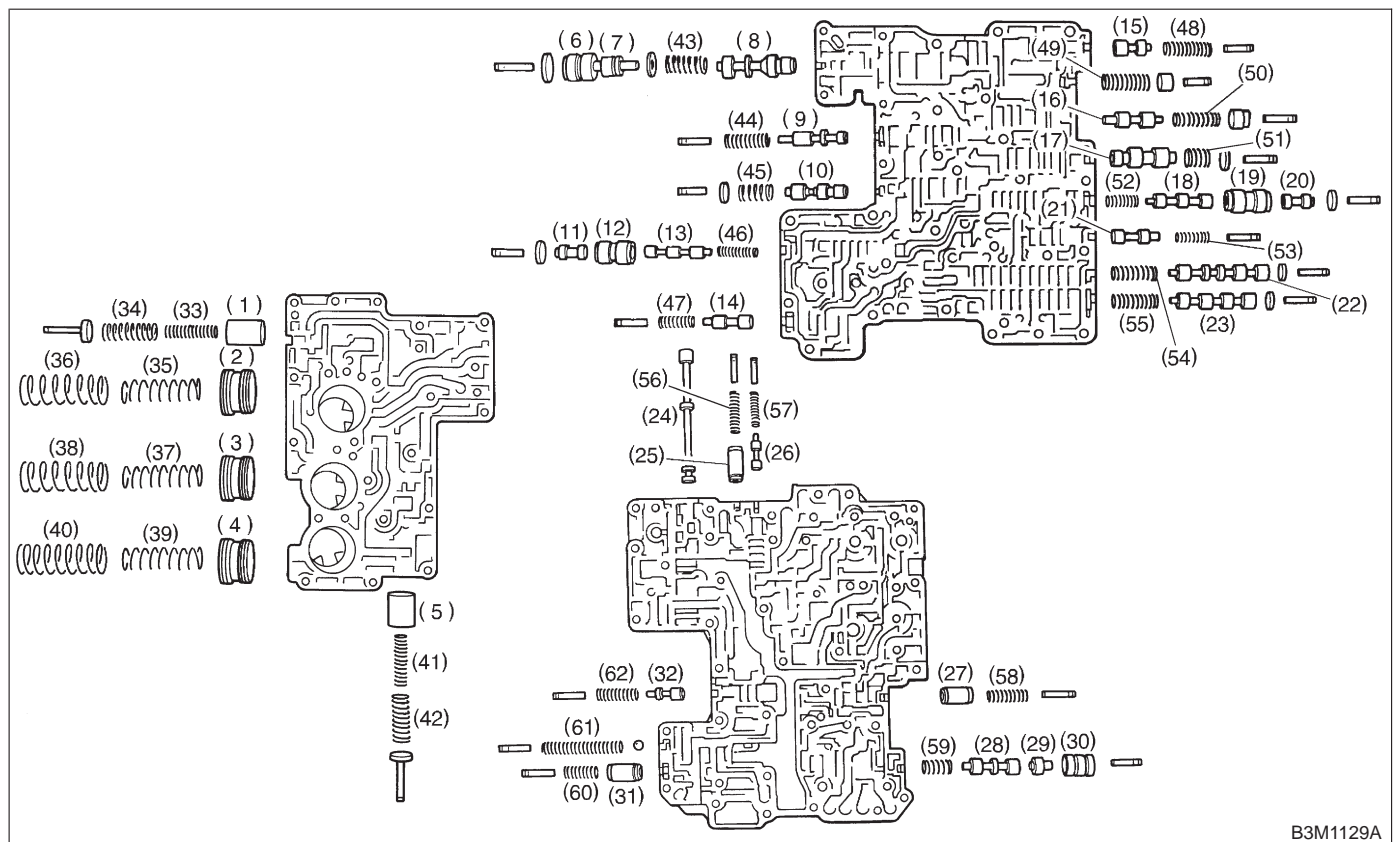

B3M1129A

- | | | |
|---|---------------------------------------|------------------------------------|
| (1) 2-4 brake clutch accumulator piston B | (11) 2-4 brake timing plug | (23) Shift valve A |
| (2) 2-4 brake clutch accumulator piston A | (12) 2-4 brake timing sleeve | (24) Manual valve |
| (3) Low clutch accumulator piston | (13) 2-4 brake timing valve A | (25) Throttle accumulator piston B |
| (4) High clutch accumulator piston A | (14) 2-4 brake timing valve B | (26) 1st reducing valve |
| (5) High clutch accumulator piston B | (15) Torque converter regulator valve | (27) Throttle accumulator piston A |
| (6) Pressure regulator sleeve | (16) Pressure modifier valve | (28) Lock-up control valve |
| (7) Pressure regulator plug | (17) Accumulator control valve A | (29) Lock-up control plug |
| (8) Pressure regulator valve | (18) Low clutch timing valve A | (30) Lock-up control sleeve |
| (9) Reverse inhibit valve | (19) Low clutch timing sleeve | (31) Modifier accumulator piston |
| (10) Accumulator control valve B | (20) Low clutch timing plug | (32) Pilot valve |
| | (21) Low clutch timing valve B | |
| | (22) Shift valve B | |

SERVICE PROCEDURE

[W14A0] **3-2**
14. Control Valve Body

No.	Part name	Wire dia. mm (in)	Average dia. mm (in)	Effective turn	Free length mm (in)
33	2-4 brake accumulator B spring (Inlet)	1.6 (0.063)	9.3 (0.366)	14.6	47.0 (1.850)
34	2-4 brake accumulator B spring (Outlet)	2.3 (0.091)	13.7 (0.539)	8.79	45.0 (1.772)
35	2-4 brake accumulator A spring (Inlet)	1.8 (0.071)	21.3 (0.839)	8.0	69.1 (2.720)
36	2-4 brake accumulator A spring (Outlet)	1.7 (0.067)	25.3 (0.996)	6.3	69.1 (2.720)
37	Low clutch accumulator spring (Inlet)	1.8 (0.071)	21.3 (0.839)	8.0	69.1 (2.720)
38	Low clutch accumulator spring (Outlet)	1.7 (0.067)	25.3 (0.996)	6.3	69.1 (2.720)
39	High clutch accumulator A spring (Inlet)	1.8 (0.071)	21.3 (0.839)	8.0	69.1 (2.720)
40	High clutch accumulator A spring (Outlet)	1.7 (0.067)	25.3 (0.996)	6.3	69.1 (2.720)
41	High clutch accumulator B spring (Inlet)	1.6 (0.063)	9.3 (0.366)	14.6	47.0 (1.850)
42	High clutch accumulator B spring (Outlet)	2.3 (0.091)	13.7 (0.539)	8.79	45.0 (1.772)
43	Pressure regulator valve spring	1.0 (0.039)	13.5 (0.531)	6.5	35.0 (1.378)
44	Reverse inhibit valve spring	0.65 (0.0256)	8.4 (0.331)	7.7	26.5 (1.043)
45	Accumulator control valve B spring	0.5 (0.020)	10.5 (0.413)	4.5	21.5 (0.846)
46	2-4 brake timing valve A spring	0.80 (0.0315)	8.2 (0.323)	7.9	25.2 (0.992)
47	2-4 brake timing valve B spring	0.60 (0.0236)	5.8 (0.228)	7.7	20.0 (0.787)
48	Torque converter regulator valve spring	1.40 (0.0551)	7.6 (0.299)	12.1	34.7 (1.366)
49	Torque converter one-way valve spring	0.8 (0.031)	9.7 (0.382)	11.5	40.0 (1.575)
50	Pressure modifier valve spring	0.7 (0.028)	8.3 (0.327)	8.2	26.9 (1.059)
51	Accumulator control valve A	0.7 (0.028)	10.3 (0.406)	3.6	15.1 (0.594)
52	Low clutch timing valve A spring	0.5 (0.020)	6.5 (0.256)	7.78	19.3 (0.760)
53	Low clutch timing valve B spring	0.60 (0.0236)	5.8 (0.228)	7.7	20.0 (0.787)
54	Shift valve B spring	0.80 (0.0315)	8.2 (0.323)	7.9	25.2 (0.992)
55	Shift valve A spring	0.80 (0.0315)	8.2 (0.323)	7.9	25.2 (0.992)
56	Throttle accumulator B spring	1.6 (0.063)	8.4 (0.331)	9.77	36.0 (1.417)
57	1st reducing valve spring	0.75 (0.0295)	6.0 (0.236)	12.5	25.4 (1.000)
58	Throttle accumulator A spring	1.7 (0.067)	8.0 (0.315)	9.61	36.0 (1.417)
59	Lock-up control valve spring	0.9 (0.035)	11.2 (0.441)	4.0	19.7 (0.776)
60	Modifier accumulator spring	1.7 (0.067)	8.0 (0.315)	9.61	36.0 (1.417)
61	Line pressure relief valve spring	1.6 (0.063)	8.0 (0.315)	22.5	69.3 (2.728)
62	Pilot valve spring	1.1 (0.043)	7.9 (0.311)	10.76	30.6 (1.205)

B: DISASSEMBLY

1) Remove oil strainer from lower control valve body.

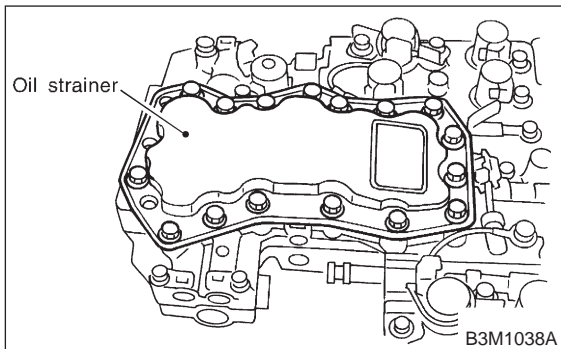

2) Remove the duty solenoid S, solenoids and sensor from the lower valve body.

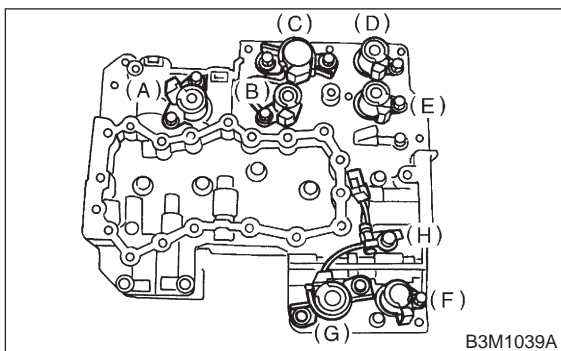

- (A) Lock-up duty solenoid (Blue)
- (B) Low clutch timing solenoid (Gray)
- (C) Line pressure duty solenoid (Red)
- (D) Shift solenoid 1 (Yellow)
- (E) Shift solenoid 2 (Green)
- (F) 2-4 brake timing solenoid (Black)
- (G) 2-4 brake duty solenoid D (Red)
- (H) ATF temperature sensor

3) Remove the upper-lower valve body tightening bolts.

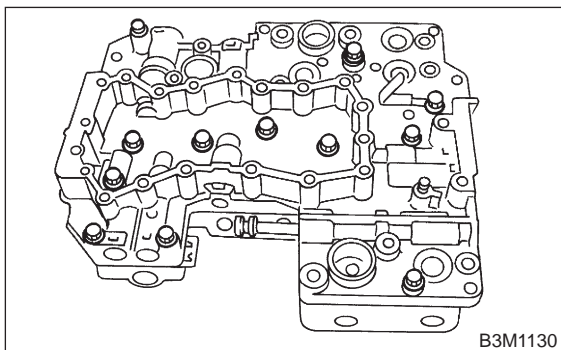

4) Separate the control valve body.

CAUTION:

- Do not lose the ten (10) steel balls contained in the upper valve body and middle valve body.
- Do not lose strainers contained in the lower valve body.

NOTE:

During ordinary servicing, clean the control valve bodies in this condition, without further disassembly. In the event of a seized clutch or other problem, disassemble the control valve bodies further, and clean the component parts.

5) Remove upper separator plate from middle valve body.

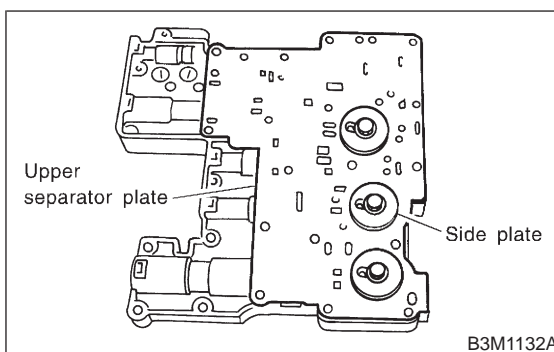

- 6) Remove valve springs from upper valve body.
- 7) Using air compressor, remove accumulator piston from upper valve body.

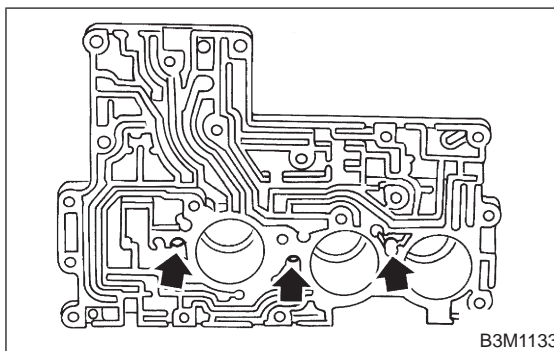

C: INSPECTION

Make sure that each component is free of harmful gouges, cuts, or dust.

D: ASSEMBLY

1) Install accumulator pistons, valve springs and steel balls to upper valve body.

CAUTION:
Insert steel balls in their proper positions.

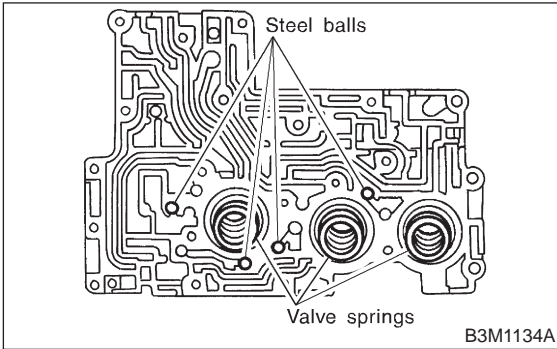

2) Install support plate and upper separate plate to middle valve body.

CAUTION:
Align the hole in support plate with the hole in separate plate.

Tightening torque:
 $8 \pm 1 \text{ N-m}$ ($0.8 \pm 0.1 \text{ kg-m}$, $5.8 \pm 0.7 \text{ ft-lb}$)

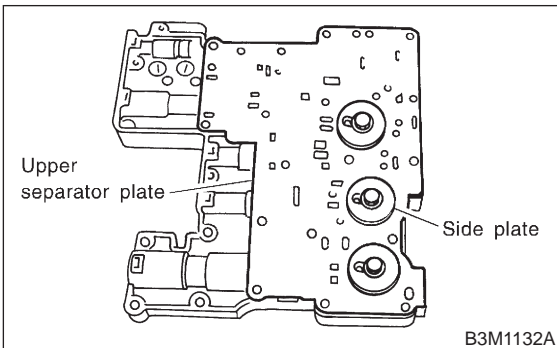

3) Install steel balls to middle valve body.

CAUTION:
Insert steel balls in their proper positions.

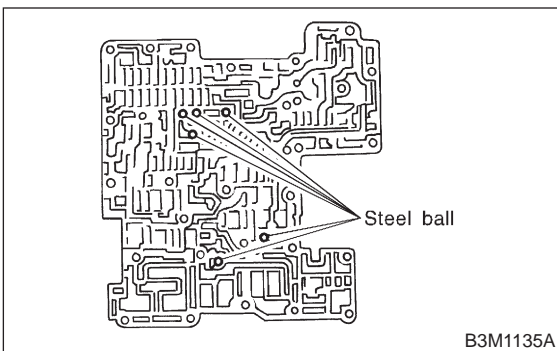

4) Install three filters to lower valve body.

CAUTION:
Pay attention to the location of filters.

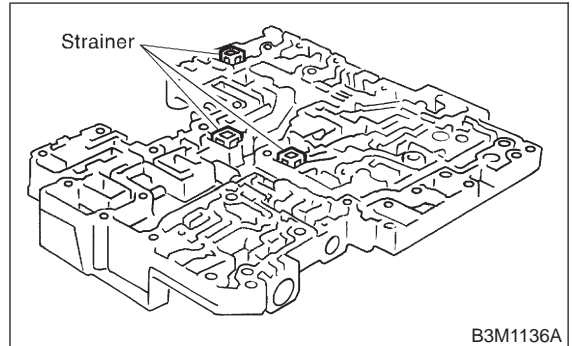

5) Install lower separator plate to lower valve body.

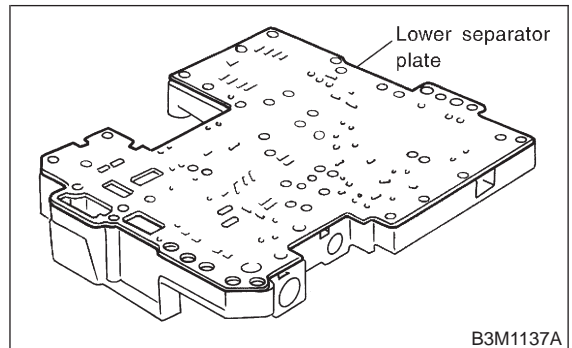

6) Temporarily assemble valve body.

CAUTION:
Be careful not to drop the middle valve body and upper body interior steel ball, or the lower body filter.

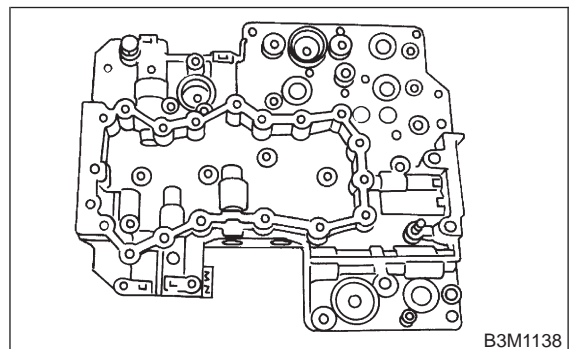

3-2 [W15A0]

15. Oil Pump Assembly

SERVICE PROCEDURE

7) Tighten bolts.

Tightening torque:

8 ± 1 N-m (0.8 ± 0.1 kg-m, 5.8 ± 0.7 ft-lb)

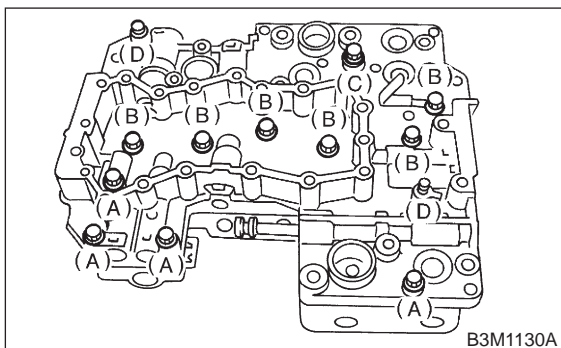

- (A) Short bolts
- (B) Middle bolts
- (C) Long bolt
- (D) Reamer bolts

8) Install the sensor, solenoids and duty solenoid S.

Tightening torque:

$T: 8\pm 1$ N-m (0.8 ± 0.1 kg-m, 5.8 ± 0.7 ft-lb)

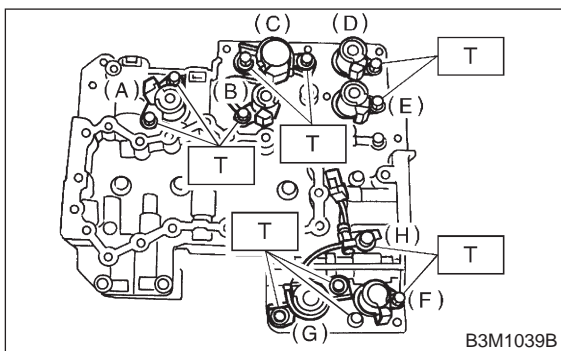

- (A) Lock-up duty solenoid (Blue)
- (B) Low clutch timing solenoid (Gray)
- (C) Line pressure duty solenoid (Red)
- (D) Shift solenoid 1 (Yellow)
- (E) Shift solenoid 2 (Green)
- (F) 2-4 brake timing solenoid (Black)
- (G) 2-4 brake duty solenoid D (Red)
- (H) ATF temperature sensor

9) Install oil strainer to lower valve body.

Tightening torque:

8 ± 1 N-m (0.8 ± 0.1 kg-m, 5.8 ± 0.7 ft-lb)

15. Oil Pump Assembly

A: DISASSEMBLY

1) Remove the oil seal retainer.
Also remove the O-ring and oil seal (air breather).

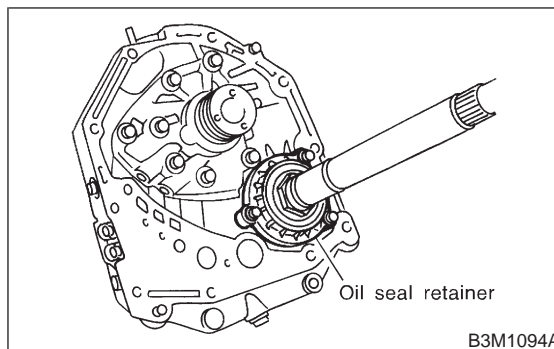

2) Remove O-rings from oil pump housing.

CAUTION:

Be careful not to damage O-ring.

3) Remove four seal rings.

CAUTION:

Be careful not to damage O-ring.

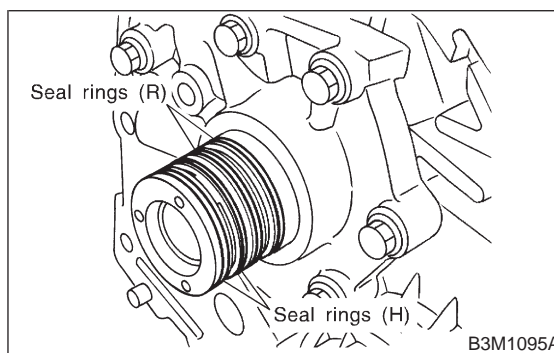

4) Remove the oil pump cover.

NOTE:

Lightly tap the end of the stator shaft to remove the cover.

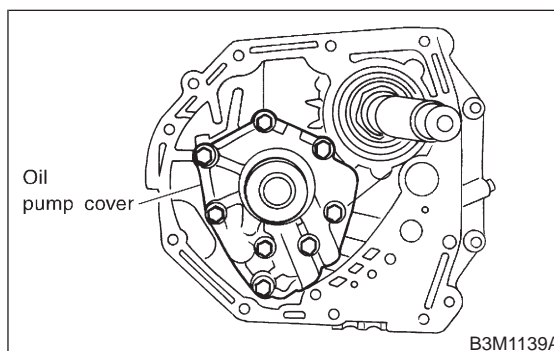

3-2 [W15A0]

15. Oil Pump Assembly

SERVICE PROCEDURE

7) Tighten bolts.

Tightening torque:

8 ± 1 N-m (0.8 ± 0.1 kg-m, 5.8 ± 0.7 ft-lb)

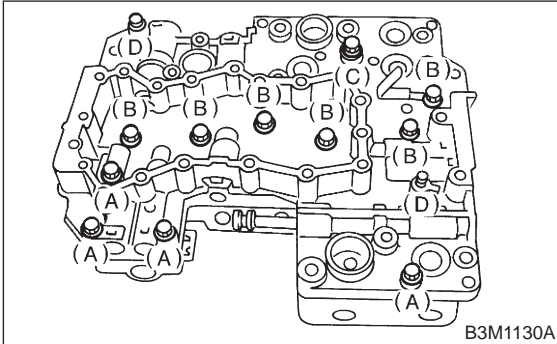

- (A) Short bolts
- (B) Middle bolts
- (C) Long bolt
- (D) Reamer bolts

8) Install the sensor, solenoids and duty solenoid S.

Tightening torque:

$T: 8\pm 1$ N-m (0.8 ± 0.1 kg-m, 5.8 ± 0.7 ft-lb)

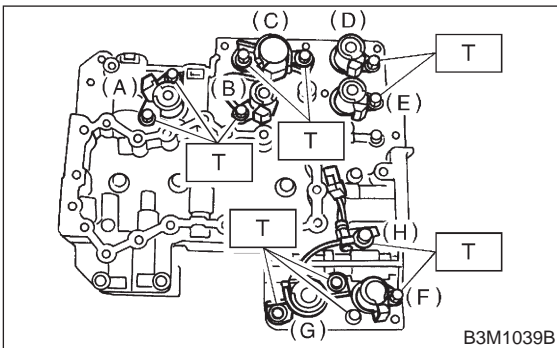

- (A) Lock-up duty solenoid (Blue)
- (B) Low clutch timing solenoid (Gray)
- (C) Line pressure duty solenoid (Red)
- (D) Shift solenoid 1 (Yellow)
- (E) Shift solenoid 2 (Green)
- (F) 2-4 brake timing solenoid (Black)
- (G) 2-4 brake duty solenoid D (Red)
- (H) ATF temperature sensor

9) Install oil strainer to lower valve body.

Tightening torque:

8 ± 1 N-m (0.8 ± 0.1 kg-m, 5.8 ± 0.7 ft-lb)

15. Oil Pump Assembly

A: DISASSEMBLY

1) Remove the oil seal retainer.
Also remove the O-ring and oil seal (air breather).

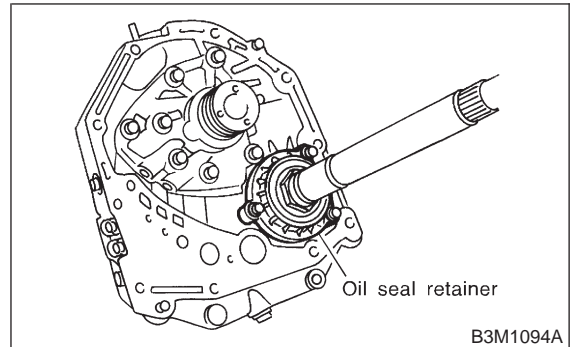

2) Remove O-rings from oil pump housing.

CAUTION:

Be careful not to damage O-ring.

3) Remove four seal rings.

CAUTION:

Be careful not to damage O-ring.

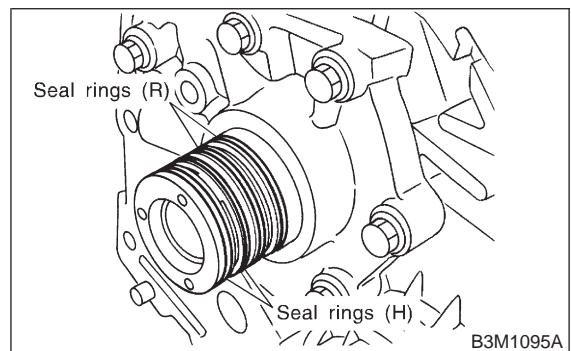

4) Remove the oil pump cover.

NOTE:

Lightly tap the end of the stator shaft to remove the cover.

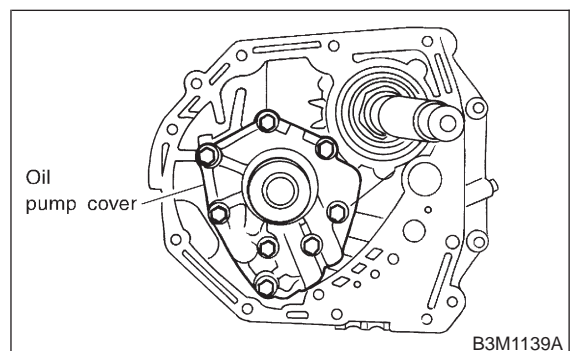

5) Remove the inner and outer rotor.

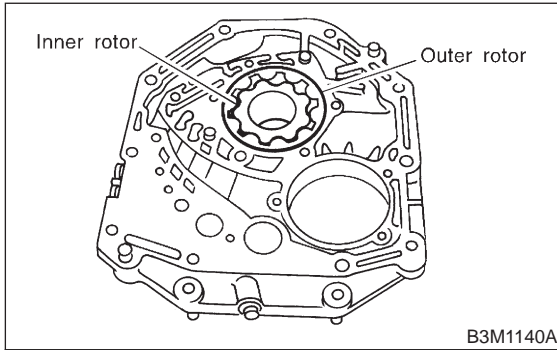

B: INSPECTION

- 1) Check seal ring and O-ring oil seal for breaks or damage.
- 2) Check other parts for dents or abnormalities.
- 3) Selection of oil pump rotor assembly
 - (1) Tip clearance
Install inner rotor and outer rotor to oil pump. With rotor gears facing each other, measure crest-to-crest clearance.

Tip clearance:
0.02 — 0.15 mm (0.0008 — 0.0059 in)

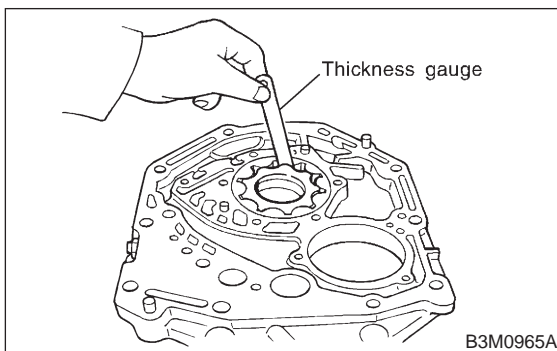

- (2) Side clearance
Set a depth gauge to oil pump housing, then measure oil pump housing-to-rotor clearances.

Side clearance:
0.02 — 0.04 mm (0.0008 — 0.0016 in)

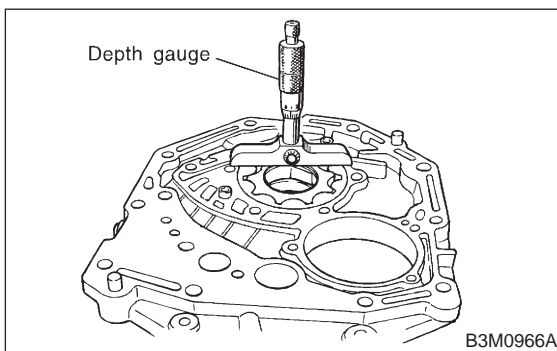

- (3) If depth and/or side clearances are outside specifications, replace rotor assembly.

Oil pump rotor assembly	
Part No.	Thickness mm (in)
15008AA060	11.37 — 11.38 (0.4476 — 0.4480)
15008AA070	11.38 — 11.39 (0.4480 — 0.4484)
15008AA080	11.39 — 11.40 (0.4484 — 0.4488)

C: ASSEMBLY

- 1) Install oil pump rotor assembly to oil pump housing.

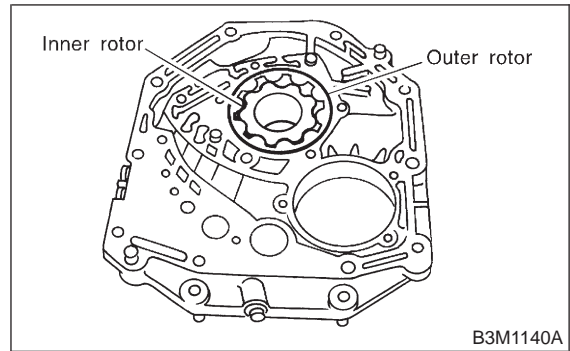

- 2) Install the oil pump cover.

Tightening torque:
25±2 N·m (2.5±0.2 kg·m, 18.1±1.4 ft·lb)

NOTE:

- Align both pivots with the pivot holes of the cover, and install the cover being careful not to apply undue force to the pivots.
- After assembling, turn the oil pump shaft to check for smooth rotation of the rotor.

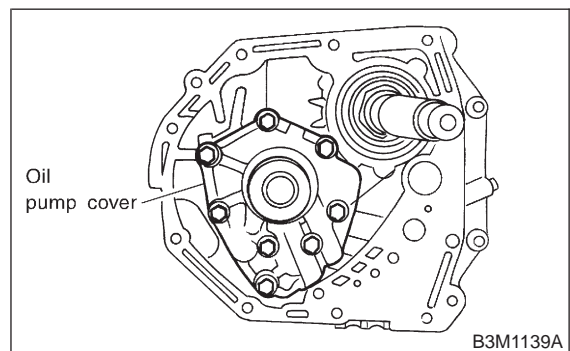

- Install the oil seal retainer and seal rings. After adjusting the drive pinion backlash and tooth contact.

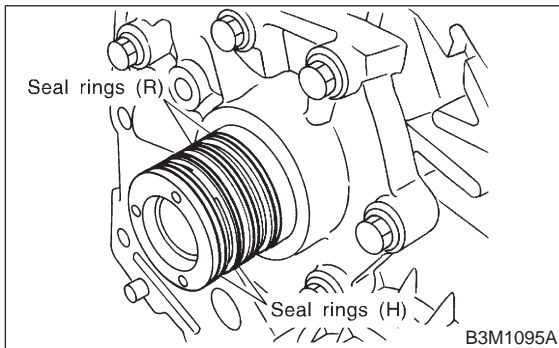

16. Drive Pinion Shaft

A: DISASSEMBLY

- 1) Straighten the staked portion of the lock nut, and remove the lock nut while locking the rear spline portion of the shaft with ST1 and ST2. Then pull off the drive pinion collar.

- ST1 498937100 HOLDER
- ST2 499787100 WRENCH
- ST3 499757800 ADAPTER

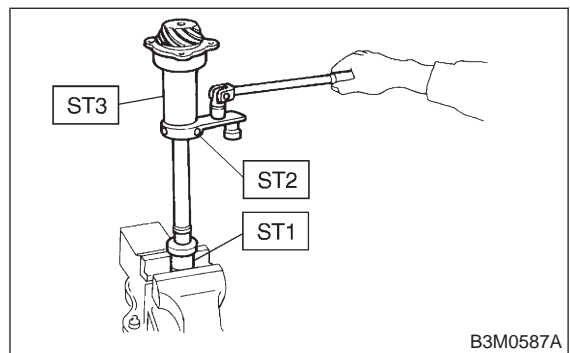

- 2) Remove the O-ring.
- 3) Using a press, separate the rear roller bearing and outer race from the shaft.

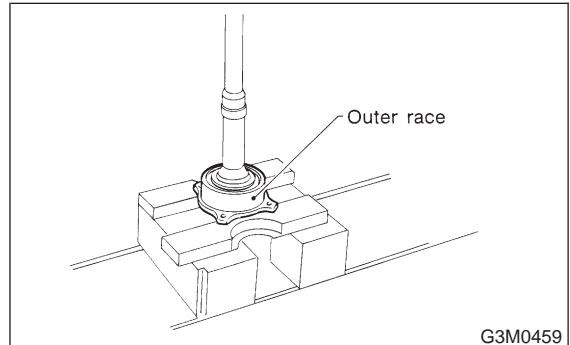

- 4) Using a press and ST, separate the front roller bearing from the shaft.

- ST 498517000 REPLACER

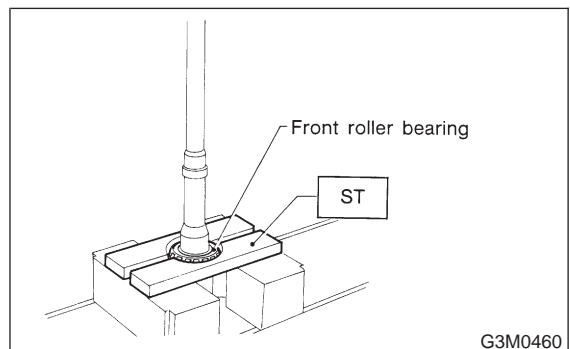

B: INSPECTION

Make sure that all component parts are free of harmful cuts, gouges, and other faults.

3-2 [W16A0]

16. Drive Pinion Shaft

SERVICE PROCEDURE

- Install the oil seal retainer and seal rings. After adjusting the drive pinion backlash and tooth contact.

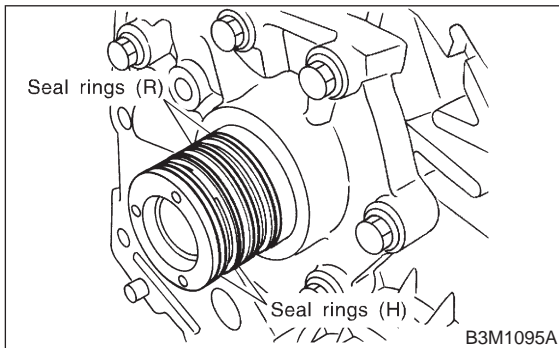

16. Drive Pinion Shaft

A: DISASSEMBLY

- 1) Straighten the staked portion of the lock nut, and remove the lock nut while locking the rear spline portion of the shaft with ST1 and ST2. Then pull off the drive pinion collar.

ST1 498937100 HOLDER
ST2 499787100 WRENCH
ST3 499757800 ADAPTER

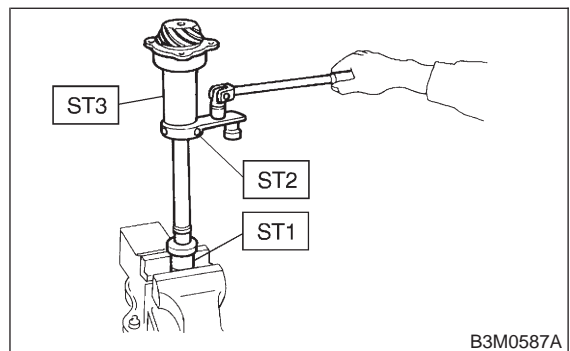

- 2) Remove the O-ring.
- 3) Using a press, separate the rear roller bearing and outer race from the shaft.

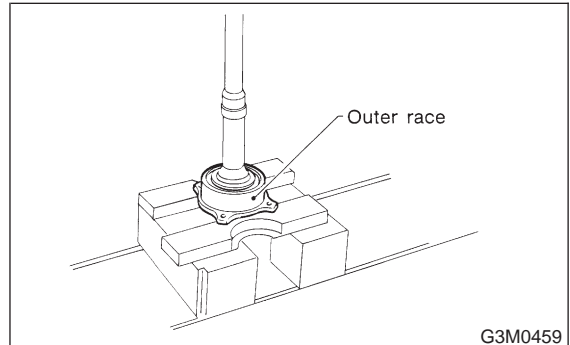

- 4) Using a press and ST, separate the front roller bearing from the shaft.

ST 498517000 REPLACER

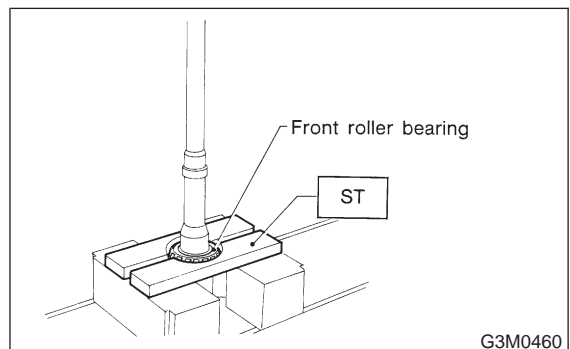

B: INSPECTION

Make sure that all component parts are free of harmful cuts, gouges, and other faults.

C: ASSEMBLY

1) Measure dimension "A" of the drive pinion shaft.

ST 398643600 GAUGE

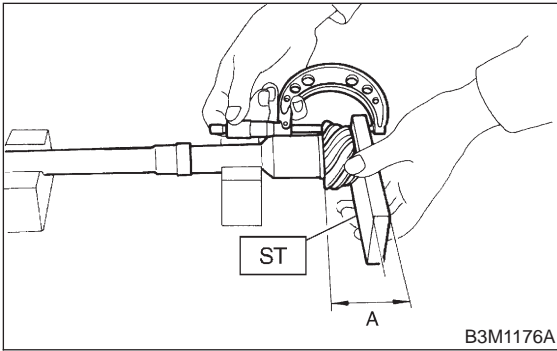

2) Using a press, force-fit the roller bearing in position.

CAUTION:

Do not change the relative positions of the outer race and bearing cone.

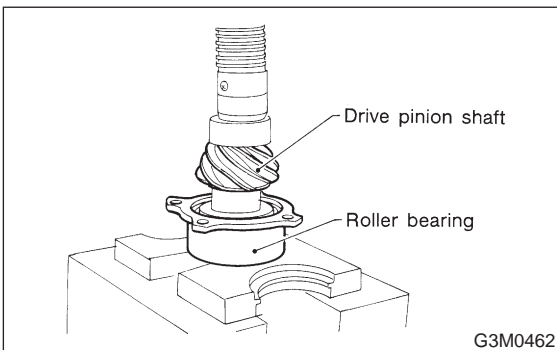

3) After fitting the O-ring to the shaft, attach the drive pinion collar to the shaft.

CAUTION:

Be careful not to damage the O-ring.

4) Tighten the lock washer and lock nut with ST1, ST2 and ST3.

ST1 498937110 HOLDER
ST2 499787100 WRENCH
ST3 499787500 ADAPTER

Actual tightening torque:

$116 \pm 5 \text{ N}\cdot\text{m}$ ($11.8 \pm 0.5 \text{ kg}\cdot\text{m}$, $85.3 \pm 3.6 \text{ ft}\cdot\text{lb}$)

NOTE:

- Pay attention to the orientation of lock washer.
- Tightening torque using torque wrench is determined by the following equation.

$$T_1 = L/L + 72.2 \times T$$

T: Actual tightening torque

- Install ST2 to torque wrench as straight as possible.

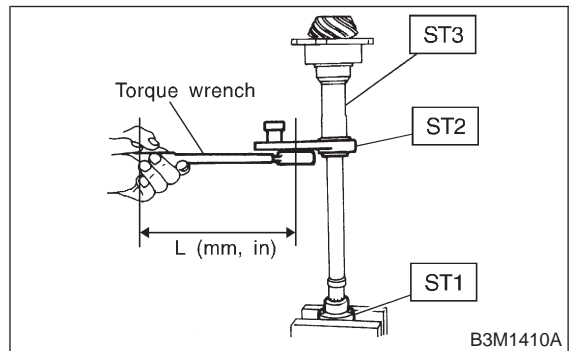

5) Measure the starting torque of the bearing. Make sure the starting torque is within the specified range. If out of the allowable range, replace the roller bearing.

Starting torque:

$0.3 - 2.0 \text{ N}\cdot\text{m}$ ($0.03 - 0.2 \text{ kg}\cdot\text{m}$, $0.2 - 1.4 \text{ ft}\cdot\text{lb}$)

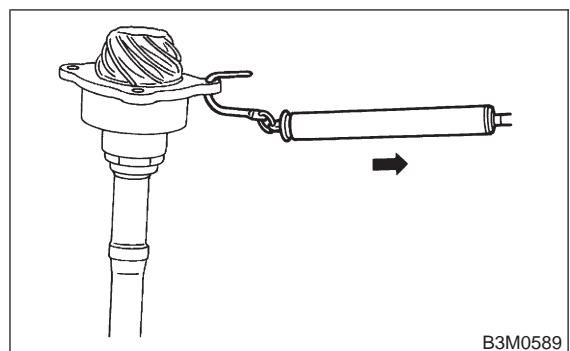

6) Stake the lock nut securely at two places.

3-2 [W16C0]

16. Drive Pinion Shaft

SERVICE PROCEDURE

7) Measure dimension "B" of the drive pinion shaft.

ST 398643600 GAUGE

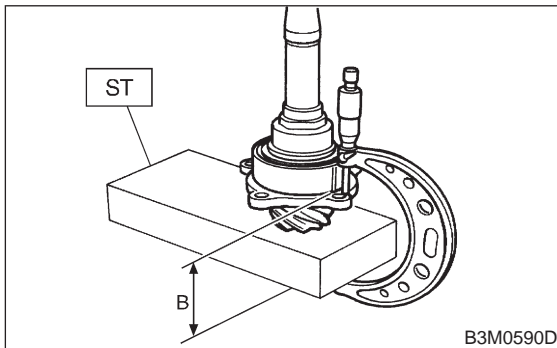

8) Determine the thickness "t" (mm) of the drive pinion shim.

NOTE:

The number of shims must be three or less.

$$t = 6.5 \pm 0.0625 - (B - A)$$

Available drive pinion shims	
Part No.	Thickness mm (in)
31451AA050	0.150 (0.0059)
31451AA060	0.175 (0.0069)
31451AA070	0.200 (0.0079)
31451AA080	0.225 (0.0089)
31451AA090	0.250 (0.0098)
31451AA100	0.275 (0.0108)

17. High Clutch and Reverse Clutch

A: DISASSEMBLY

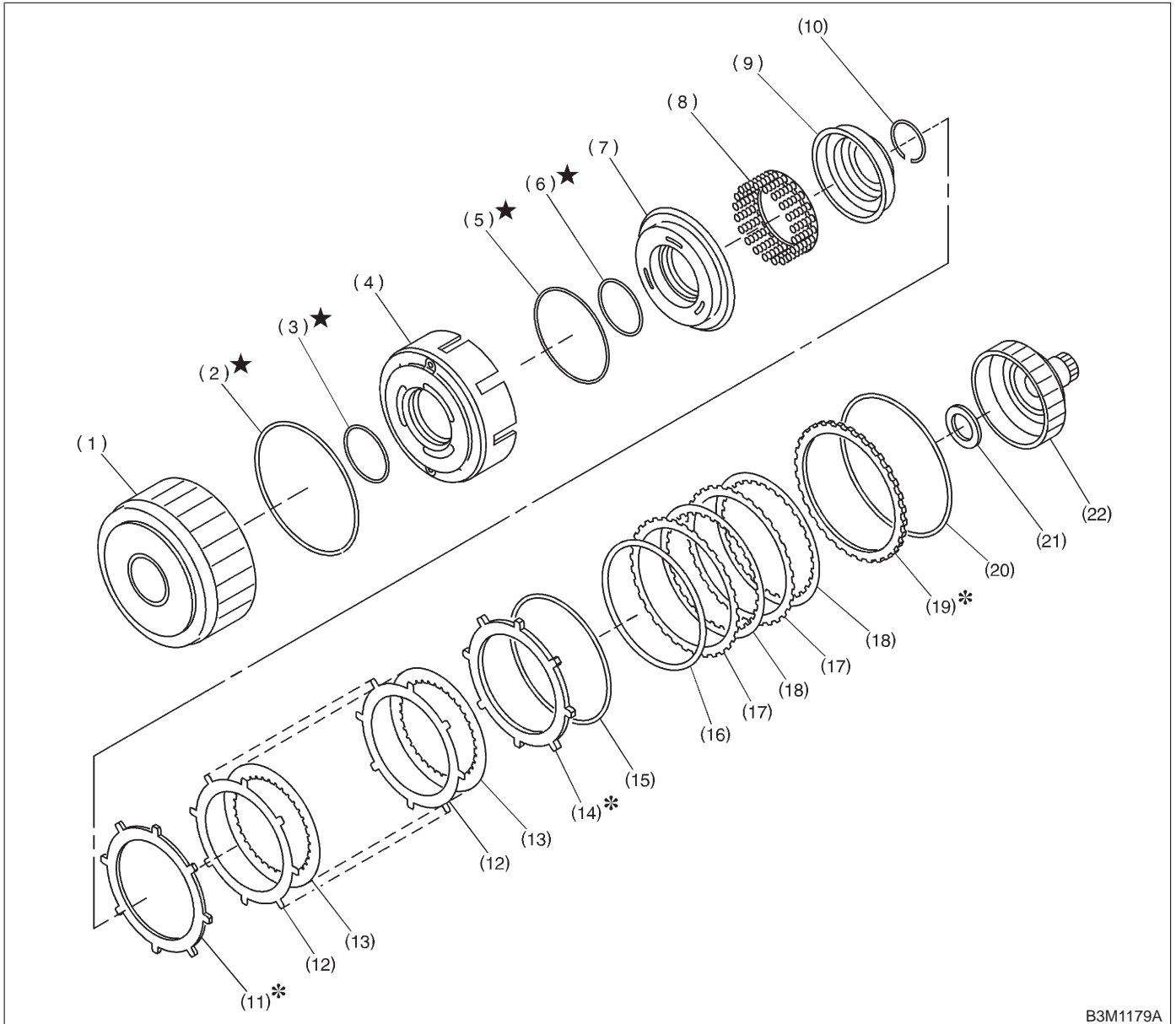

B3M1179A

- | | | |
|---------------------------|-----------------------------|----------------------------|
| (1) Reverse clutch drum | (9) Cover | (17) Driven plate |
| (2) Lip seal | (10) Snap ring | (18) Drive plate |
| (3) Lathe cut seal ring | (11) Driven plate (Thicker) | (19) Retaining plate |
| (4) Reverse clutch piston | (12) Driven plate | (20) Snap ring |
| (5) Lathe cut seal ring | (13) Drive plate | (21) Thrust needle bearing |
| (6) Lathe cut seal ring | (14) Retaining plate | (22) High clutch hub |
| (7) High clutch piston | (15) Snap ring | |
| (8) Spring retainer | (16) Dish plate | |

3-2 [W17B0]

17. High Clutch and Reverse Clutch

SERVICE PROCEDURE

1) Remove the snap ring, and take out the retaining plate, drive plates, driven plates.

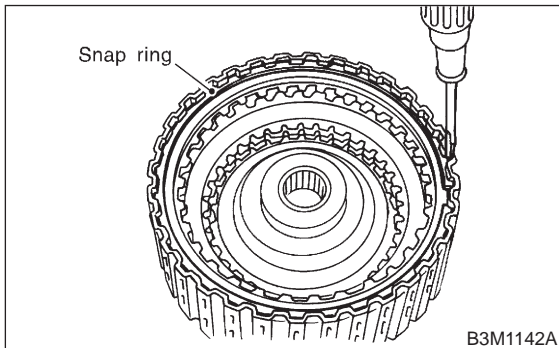

2) Remove snap ring, and take out the retaining plate, drive plates and driven plates.

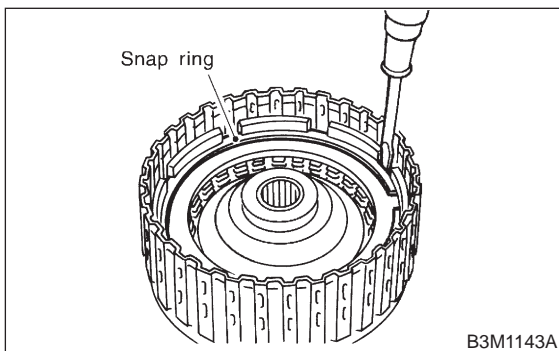

3) Using ST1 and ST2, remove snap ring.
ST1 398673600 COMPRESSOR
ST2 498627100 SEAT

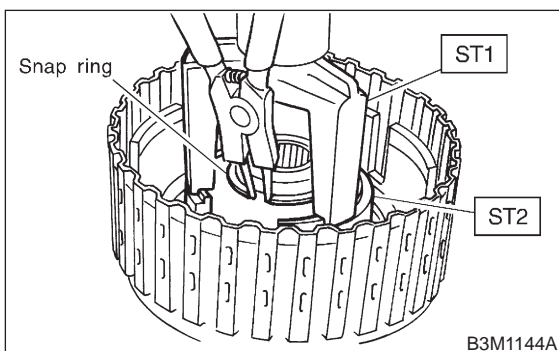

4) Take out clutch cover, spring retainer, high clutch piston and reverse clutch piston.

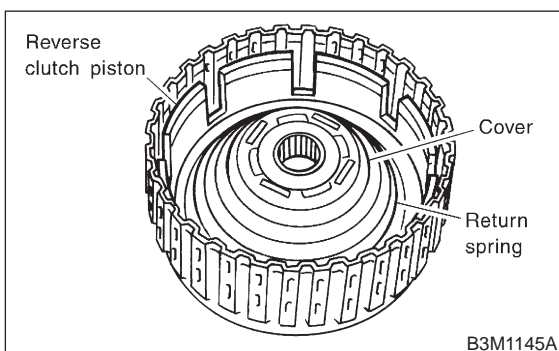

5) Remove seal rings and lip seal from high clutch piston and reverse clutch piston.

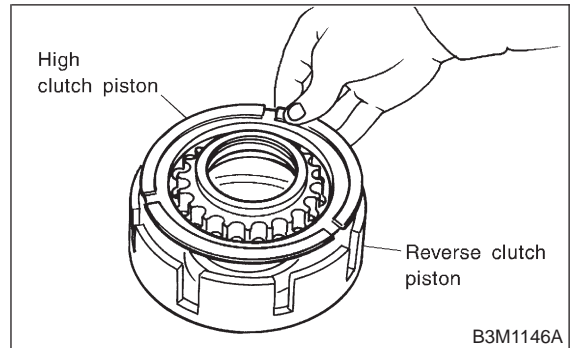

B: INSPECTION

- 1) Drive plate facing for wear and damage
- 2) Snap ring for wear, return spring for breakage or setting, and spring retainer for deformation
- 3) Lip seal and lathe cut seal ring for damage
- 4) Piston check ball for operation

C: ASSEMBLY

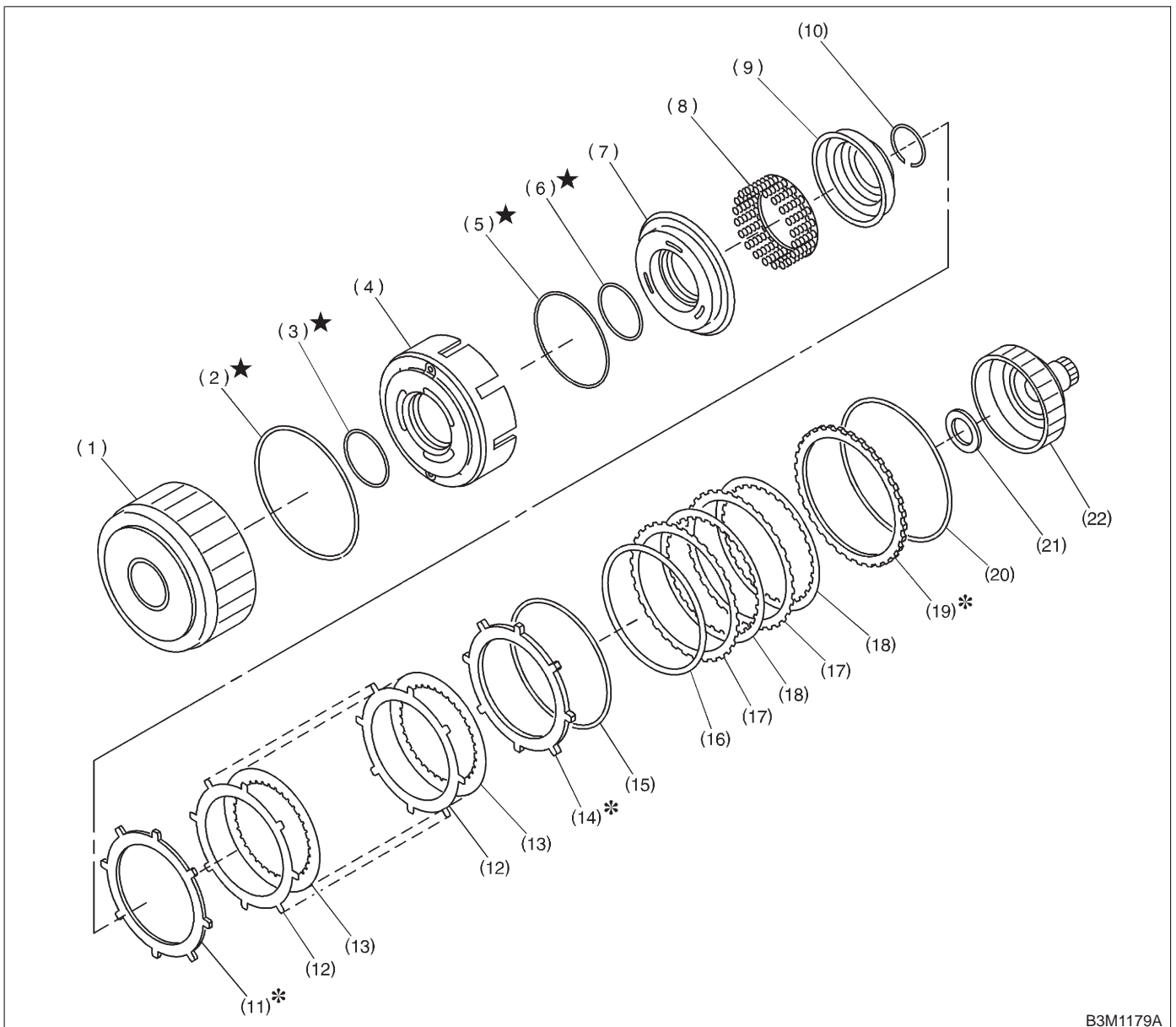

B3M1179A

- | | | |
|---------------------------|-----------------------------|----------------------------|
| (1) Reverse clutch drum | (9) Cover | (17) Driven plate |
| (2) Lip seal | (10) Snap ring | (18) Drive plate |
| (3) Lathe cut seal ring | (11) Driven plate (Thicker) | (19) Retaining plate |
| (4) Reverse clutch piston | (12) Driven plate (Thinner) | (20) Snap ring |
| (5) Lathe cut seal ring | (13) Drive plate | (21) Thrust needle bearing |
| (6) Lathe cut seal ring | (14) Retaining plate | (22) High clutch hub |
| (7) High clutch piston | (15) Snap ring | |
| (8) Spring retainer | (16) Dish plate | |

3-2 [W17C0]

17. High Clutch and Reverse Clutch

SERVICE PROCEDURE

- 1) Install seal rings and lip seal to high clutch piston and reverse clutch piston.
- 2) Install high clutch piston to reverse clutch piston.

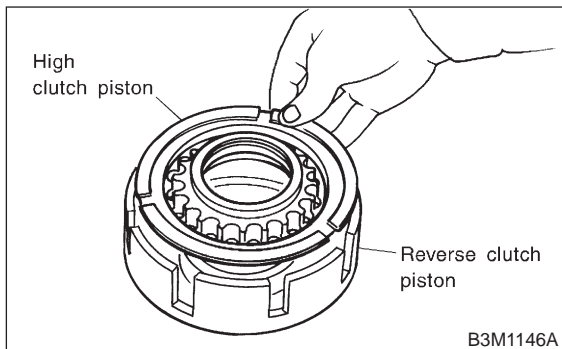

- 3) Install reverse clutch to high clutch drum.

NOTE:

Align the groove on the reverse clutch piston with the groove on the high clutch drum during installation.

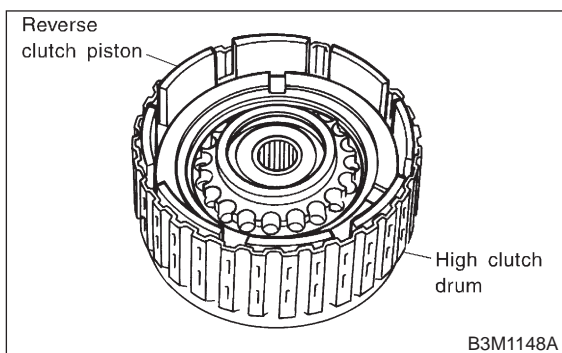

- 4) Install spring retainer to high clutch piston.

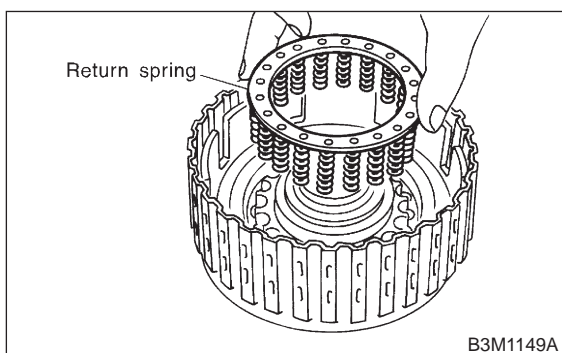

- 5) Install ST to high clutch piston.
ST 498437000 HIGH CLUTCH PISTON GAUGE

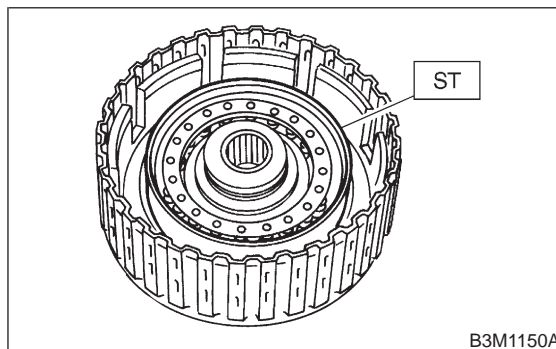

- 6) Install cover to high clutch piston.

CAUTION:

Be careful not to fold over the high clutch piston seal during installation.

- 7) Using ST1 and ST2, install snap ring.

NOTE:

After installing snap ring, remove STs.

- | | | |
|-----|-----------|--------------------------|
| ST1 | 398673600 | COMPRESSOR |
| ST2 | 498627100 | SEAT |
| ST3 | 498437000 | HIGH CLUTCH PISTON GAUGE |

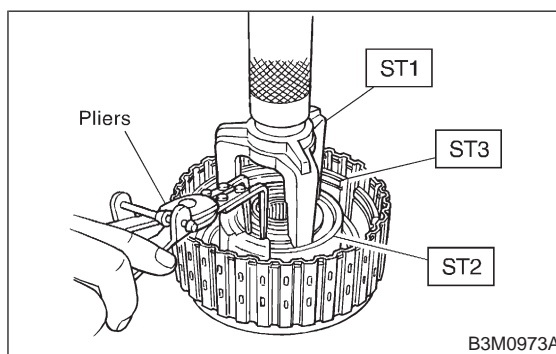

- 8) Install driven plate, drive plate and retaining plate to high clutch drum.

NOTE:

Install thicker driven plate on the piston side.

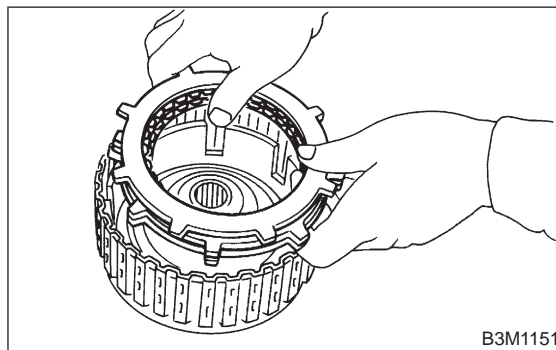

- 9) Install snap ring to high clutch drum.

10) Apply compressed air intermittently to check for operation.

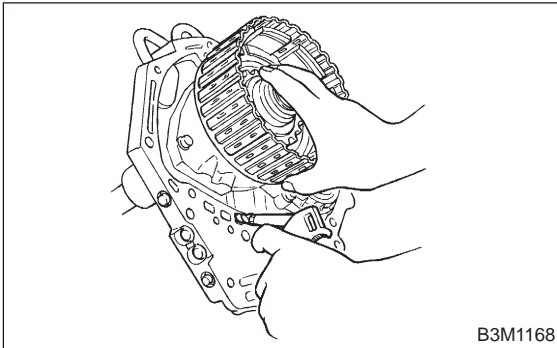

11) Measure the clearance between the retaining plate and snap ring.

CAUTION:
Do not press down retaining plate during clearance measurements.

Standard value:
0.8 — 1.1 mm (0.031 — 0.043 in)

Allowable limit:
1.5 mm (0.059 in)

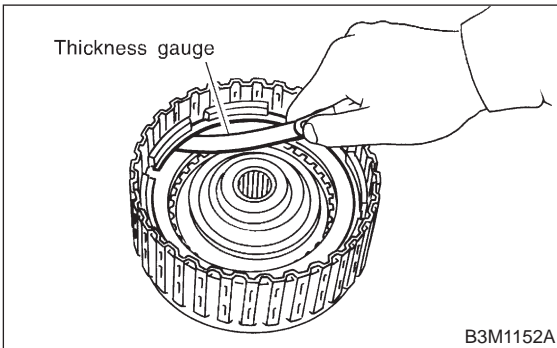

12) If specified tolerance limits are exceeded, select a suitable high clutch retaining plate.

High clutch retaining plate	
Part No.	Thickness mm (in)
31567AA710	4.7 (0.185)
31567AA720	4.8 (0.189)
31567AA730	4.9 (0.193)
31567AA740	5.0 (0.197)
31567AA670	5.1 (0.201)
31567AA680	5.2 (0.205)
31567AA690	5.3 (0.209)
31567AA700	5.4 (0.213)

13) Install driven plate, drive plate, retaining plate and snap ring.

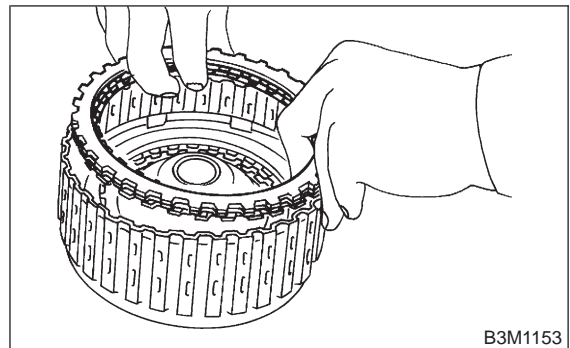

14) Apply compressed air intermittently to check for operation.

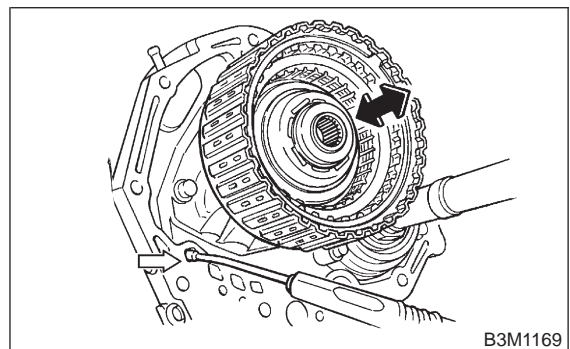

3-2 [W17C0]

17. High Clutch and Reverse Clutch

SERVICE PROCEDURE

15) Measure the clearance between the retaining plate and snap ring.

CAUTION:

Do not press down retaining plate during clearance measurements.

Standard value:

0.5 — 0.8 mm (0.020 — 0.031 in)

Allowable limit:

1.2 mm (0.047 in)

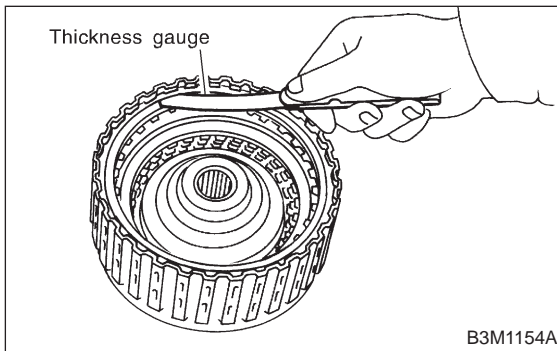

16) If specified tolerance limits are exceeded, select a suitable high clutch retaining plate.

Reverse clutch retaining plates	
Part No.	Thickness mm (in)
31567AA750	3.8 (0.150)
31567AA760	4.0 (0.157)
31567AA770	4.2 (0.165)
31567AA780	4.4 (0.173)
31567AA790	4.6 (0.181)
31567AA800	4.8 (0.189)
31567AA810	5.0 (0.197)
31567AA820	5.2 (0.205)

18. Low Clutch Drum and Planetary Gear

A: DISASSEMBLY

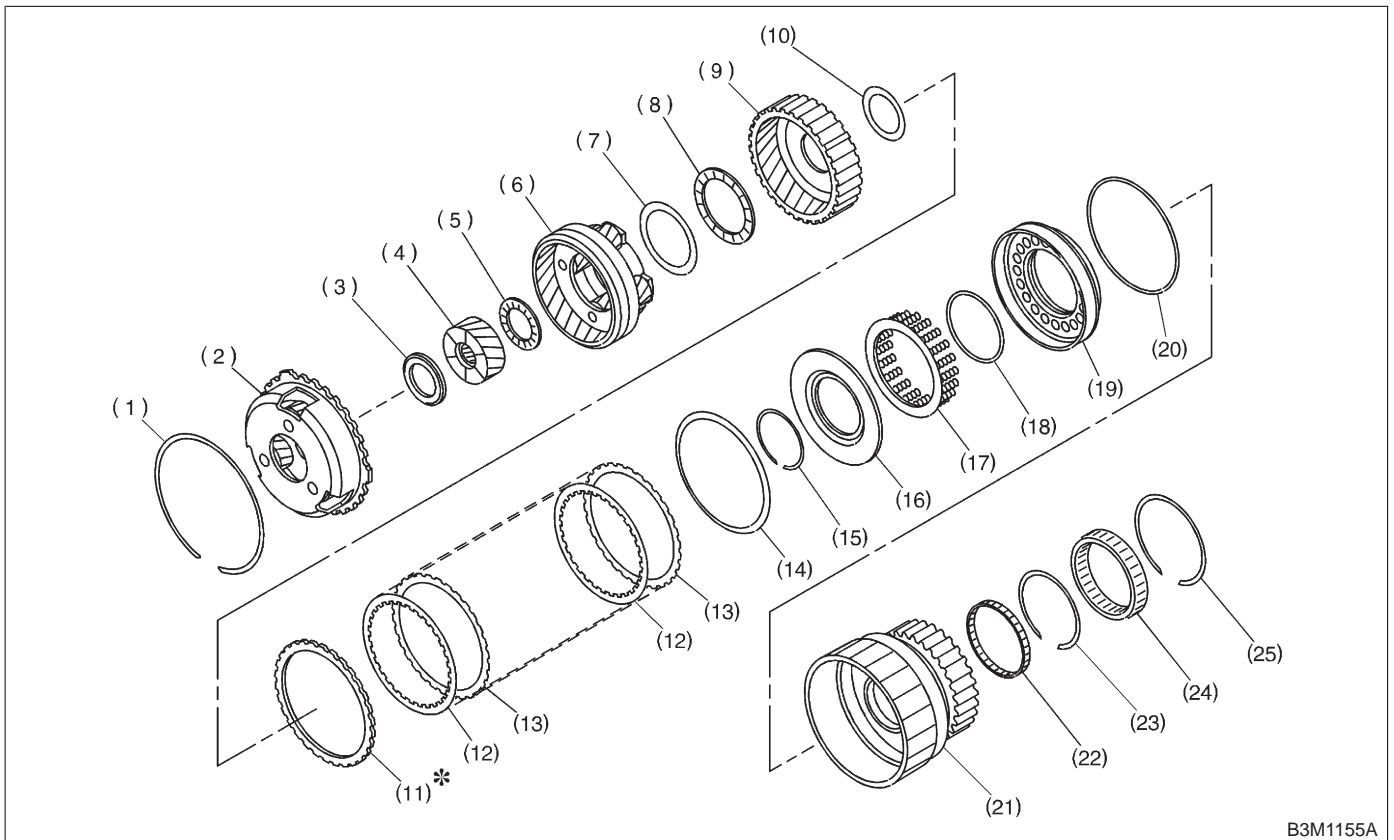

B3M1155A

- | | | |
|-----------------------------|--------------------------|--------------------------|
| (1) Snap ring | (10) Washer | (19) Low clutch piston |
| (2) Front planetary carrier | (11) Retaining plate | (20) Lathe cut seal ring |
| (3) Thrust needle bearing | (12) Drive plate | (21) Low clutch drum |
| (4) Rear sun gear | (13) Driven plate | (22) Needle bearing |
| (5) Thrust needle bearing | (14) Dish plate | (23) Inner snap ring |
| (6) Rear planetary carrier | (15) Snap ring | (24) One-way clutch |
| (7) Washer | (16) Cover | (25) Outer snap ring |
| (8) Thrust needle bearing | (17) Spring retainer | |
| (9) Rear internal gear | (18) Lathe cut seal ring | |

3-2 [W18A0]

SERVICE PROCEDURE

18. Low Clutch Drum and Planetary Gear

1) Remove snap ring from the low clutch drum.

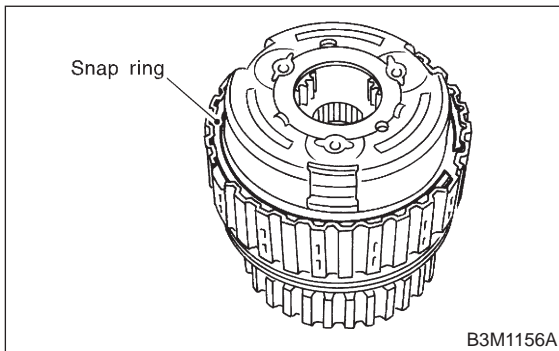

5) Take out rear internal gear.

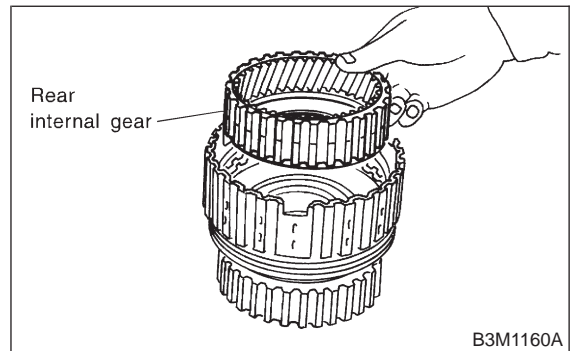

2) Take out front planetary carrier and thrust needle bearing from low clutch drum.

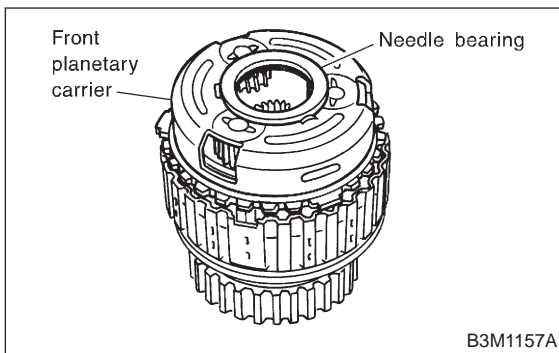

6) Remove the snap ring from the low clutch drum.

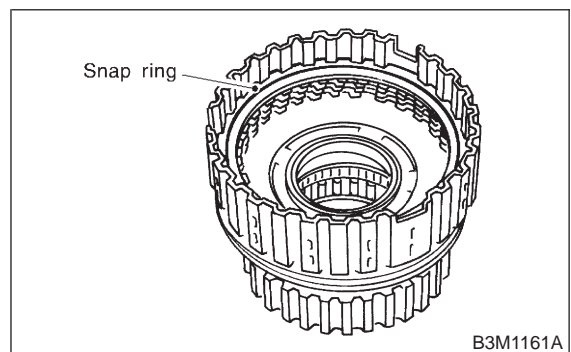

3) Take out rear sun gear.

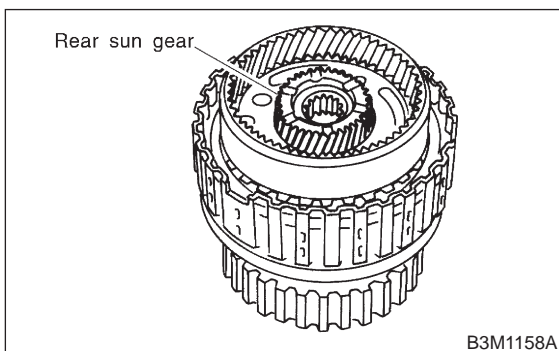

7) Remove the retaining plate, drive plates, driven plates and dish plate.

8) Compress the spring retainer, and remove the snap ring from the low clutch drum, by using ST1 and ST2.

ST1 498627100 SEAT
ST2 398673600 COMPRESSOR

4) Take out rear planetary carrier, washer and thrust needle bearing.

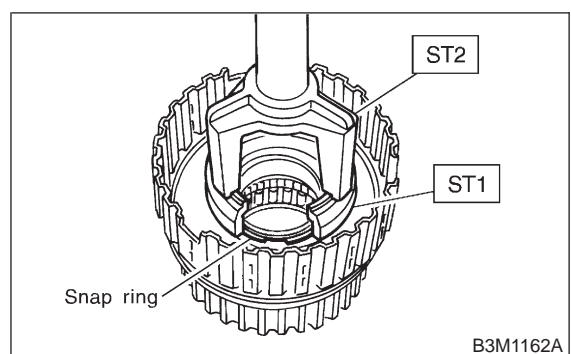
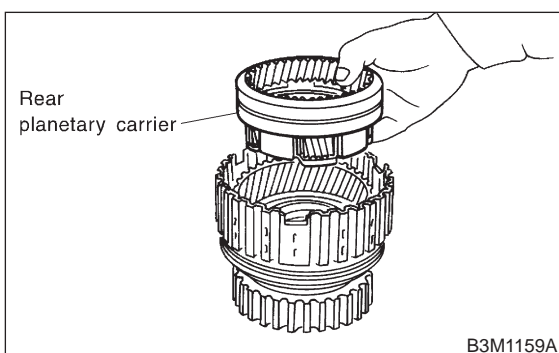

9) Install the one-way clutch inner race to the low clutch drum, and apply compressed air to remove the low clutch piston.

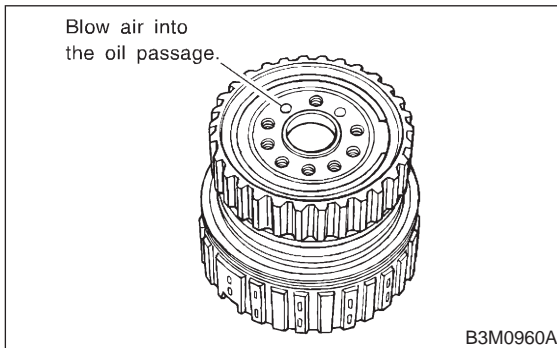

10) Remove the one-way clutch inner race.
 11) Remove the one-way clutch after taking out the snap ring.

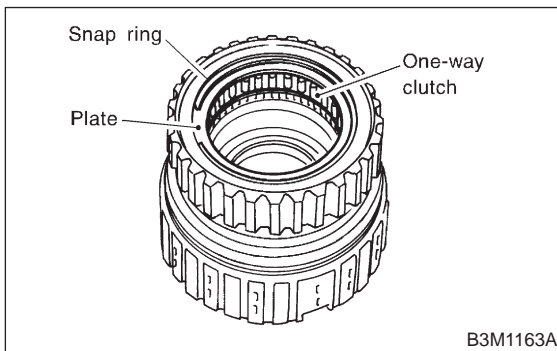

12) Remove the needle bearing after taking out the snap ring.

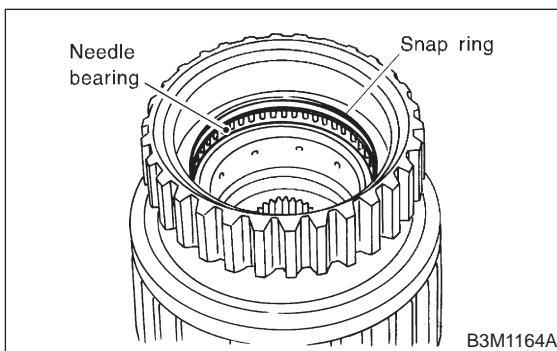

B: INSPECTION

- 1) Drive plate facing for wear and damage
- 2) Snap ring for wear, return spring for setting and breakage, and snap ring retainer for deformation
- 3) Lip seal and lathe cut ring for damage
- 4) Piston and drum check ball for operation

C: ASSEMBLY

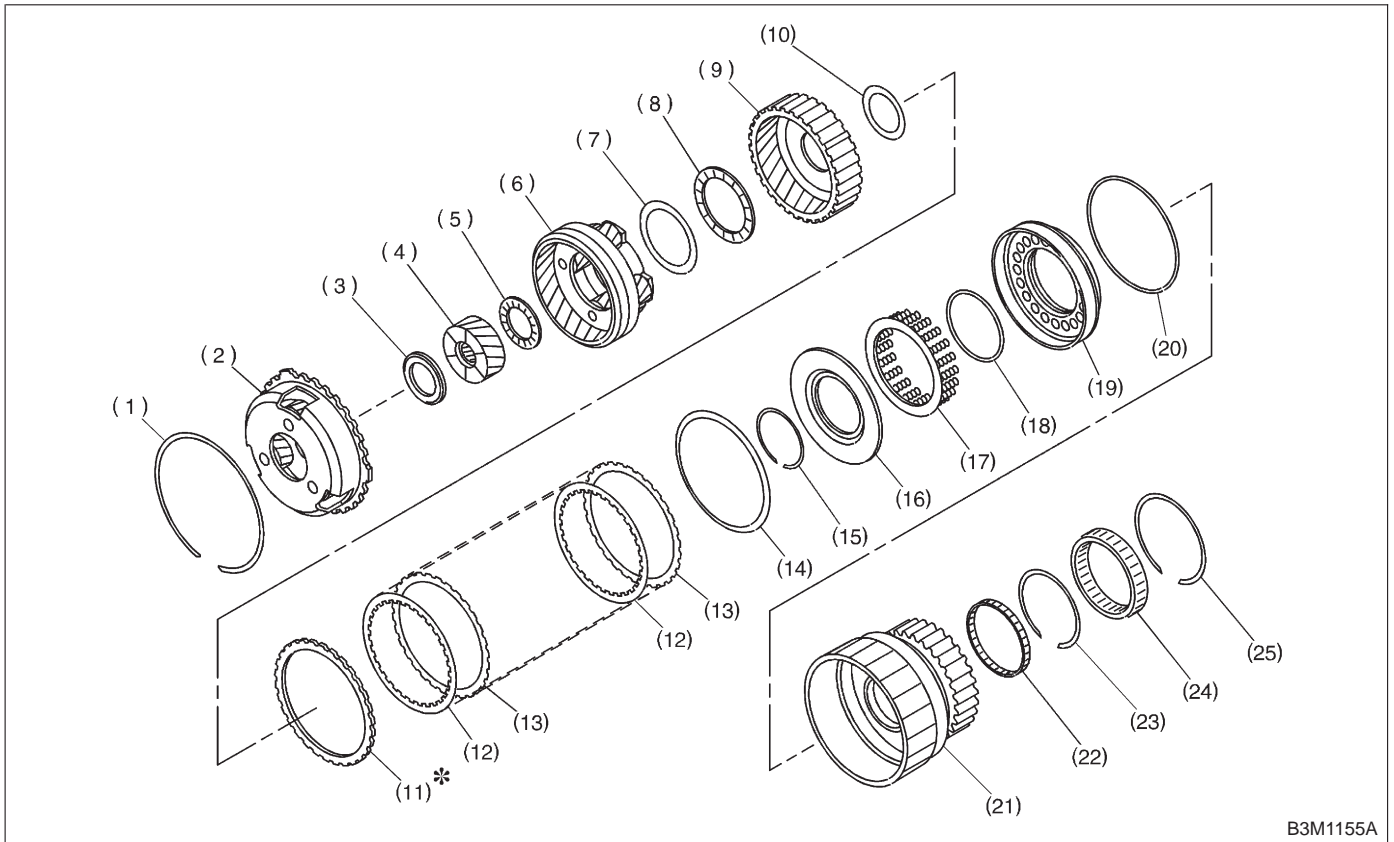

B3M1155A

- | | | |
|-----------------------------|--------------------------|--------------------------|
| (1) Snap ring | (10) Washer | (19) Low clutch piston |
| (2) Front planetary carrier | (11) Retaining plate | (20) Lathe cut seal ring |
| (3) Thrust needle bearing | (12) Drive plate | (21) Low clutch drum |
| (4) Rear sun gear | (13) Driven plate | (22) Needle bearing |
| (5) Thrust needle bearing | (14) Dish plate | (23) Inner snap ring |
| (6) Rear planetary carrier | (15) Snap ring | (24) One-way clutch |
| (7) Washer | (16) Cover | (25) Outer snap ring |
| (8) Thrust needle bearing | (17) Spring retainer | |
| (9) Rear internal gear | (18) Lathe cut seal ring | |

- 1) Install lathe cut seal ring to low clutch piston.
- 2) Fit the low clutch piston to the low clutch drum.

- 3) Install spring retainer to low clutch piston.

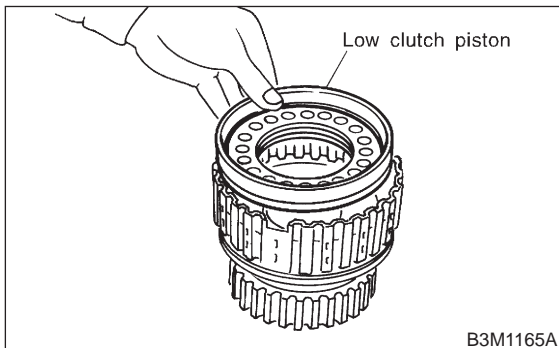

B3M1165A

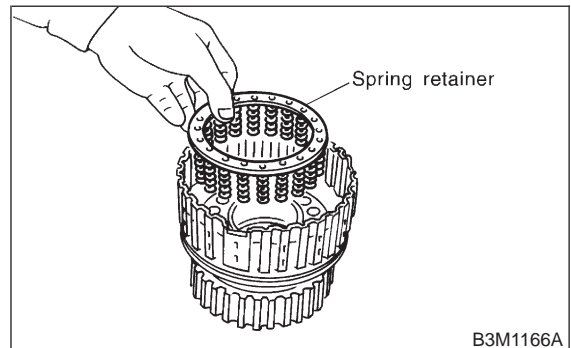

B3M1166A

- 4) Install ST to low clutch drum.
 ST 498437100 LOW CLUTCH PISTON GUIDE

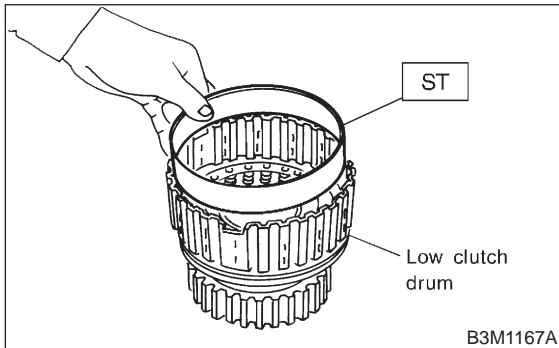

- 5) Set the cover on the piston with a press using ST1 and ST2, and attach the snap ring.

CAUTION:
 Be careful not to fold cover seal during installation.

NOTE:
 After installing snap ring, remove ST1, ST2 and ST3.

- ST1 498627100 SEAT
 ST2 398673600 COMPRESSOR
 ST3 498437100 LOW CLUTCH PISTON GUIDE

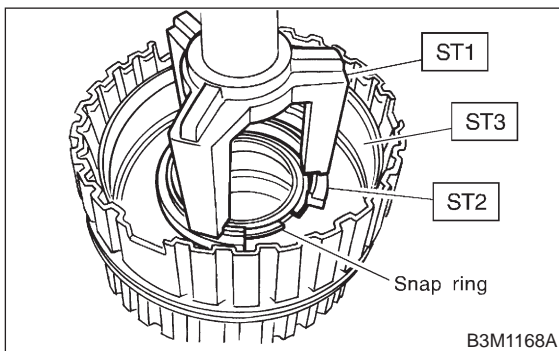

- 6) Install the dish plate, driven plates, drive plates, and retaining plate, and secure with the snap ring.

NOTE:
 Pay attention to the orientation of the dish plate.

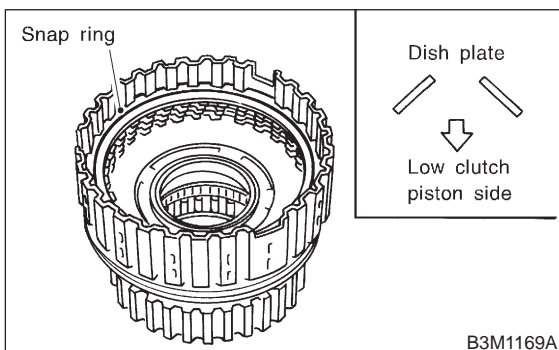

- 7) Check the low clutch for operation.
 Set the one-way clutch inner race, and apply compressed air for checking.

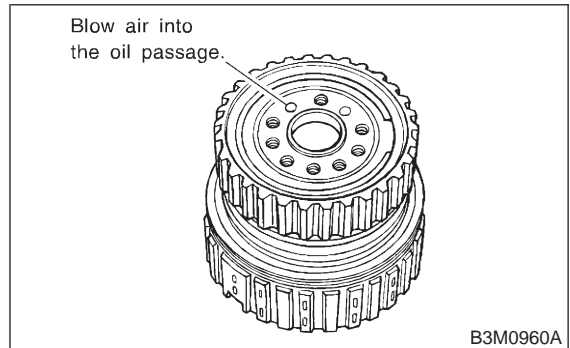

- 8) Checking low clutch clearance
 Measure the gap between the retaining plate and the operation of the low clutch.

NOTE:
 Before measuring clearance, place the same thickness of shim on both sides to prevent retaining plate from tilting.
 If the clearance is out of the specified range, select a proper retaining plate so that the standard clearance can be obtained.

Standard value:
 0.7 — 1.1 mm (0.028 — 0.043 in)

Allowable limit:
 1.6 mm (0.063 in)

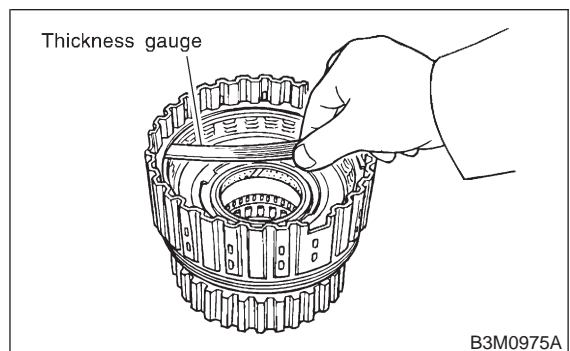

Available retaining plates	
Part No.	Thickness mm (in)
31567AA830	3.8 (0.150)
31567AA840	4.0 (0.157)
31567AA850	4.2 (0.165)
31567AA860	4.4 (0.173)
31567AA870	4.6 (0.181)

3-2 [W18C0]

SERVICE PROCEDURE

18. Low Clutch Drum and Planetary Gear

9) Install washer to rear internal gear.

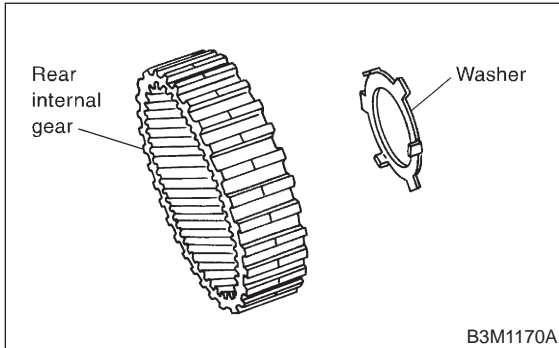

10) Install rear internal gear.

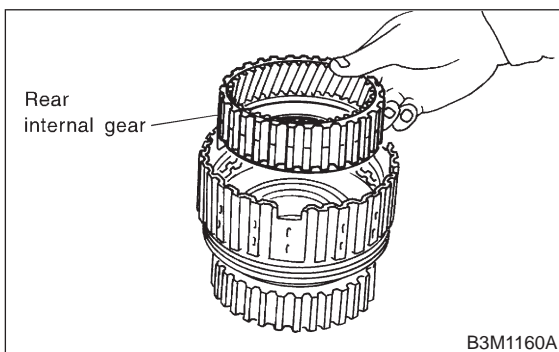

11) Install thrust needle bearing.

CAUTION:
Install thrust needle bearing in the correct direction. <Ref. to 3-2 [S1C0].>

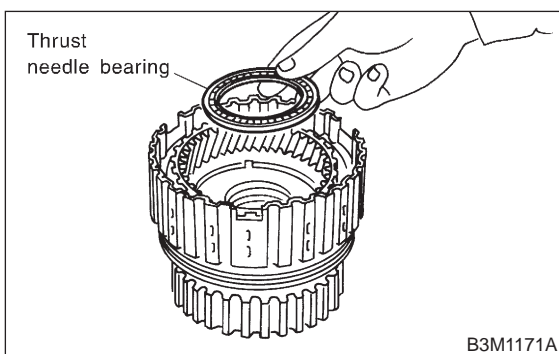

12) Install washer to rear planetary carrier.

NOTE:

Make sure washer tooth is inserted into hole on planetary carrier.

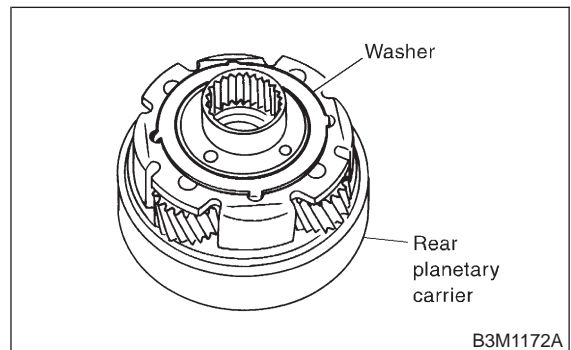

13) Install rear planetary carrier to low clutch drum.

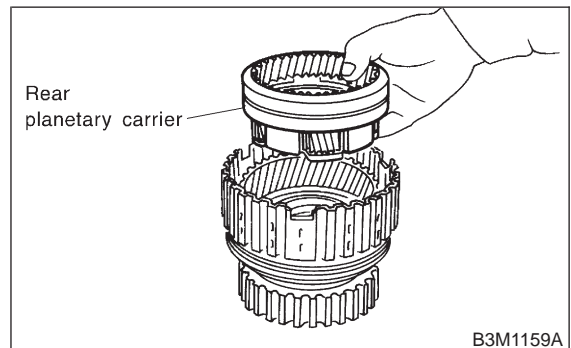

14) Install thrust needle bearing to rear planetary carrier.

CAUTION:
Install thrust needle bearing in the correct direction. <Ref. to 3-2 [S1C0].>

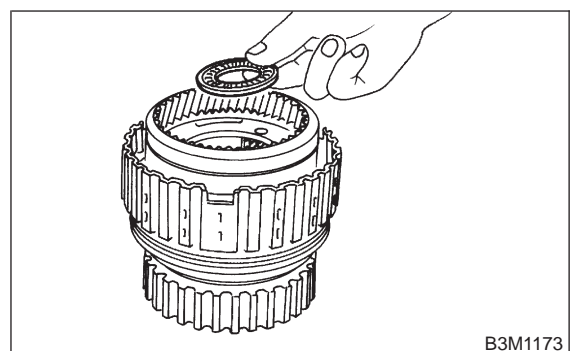

15) Install rear sun gear.

NOTE:

Pay attention to the orientation of the rear sun gear.

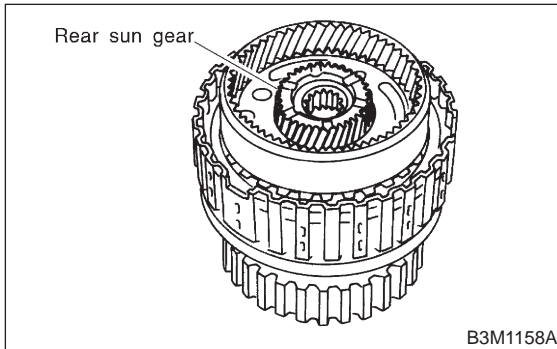

16) Install thrust needle bearing to front planetary carrier.

NOTE:

Pay attention to the orientation of the thrust needle bearing.

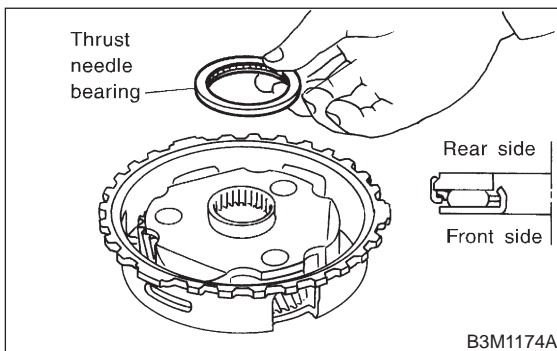

17) Install front planetary carrier to low clutch drum.

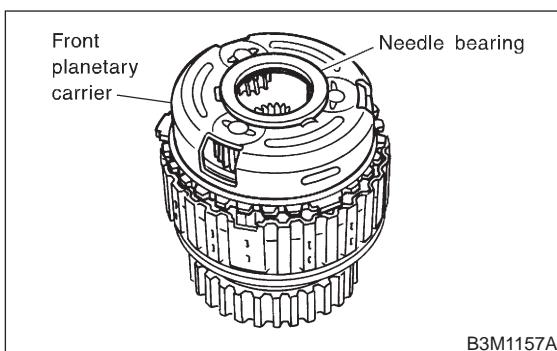

18) Install snap ring to low clutch drum.

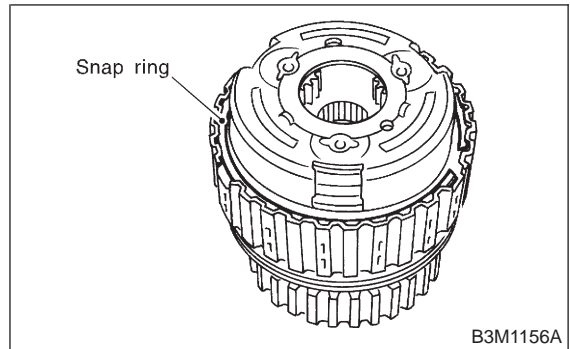

19) Install the needle bearing, and secure with the snap ring.

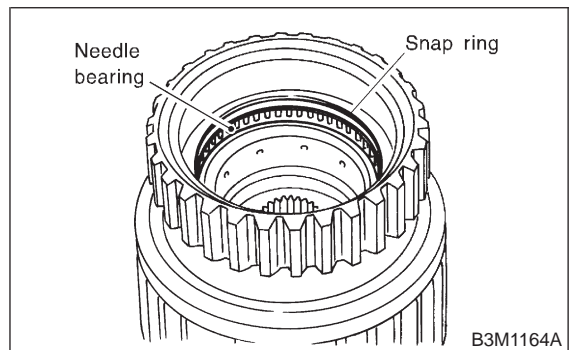

20) Install the one-way clutch, one-way clutch inner race and plate, and secure with the snap ring.

NOTE:

Set the inner race. Make sure that the forward clutch is free in the clockwise direction and locked in the counterclockwise direction, as viewed from the front of the vehicle.

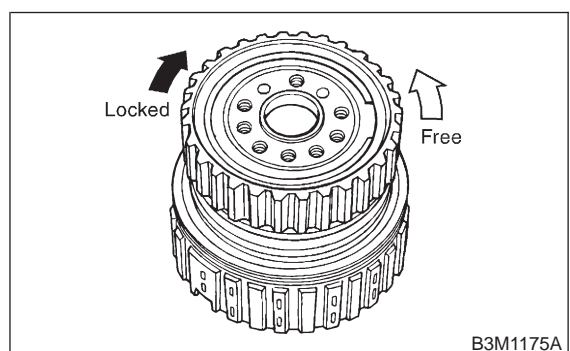

19. Differential Case Assembly

A: DISASSEMBLY

1) Using a press and ST, remove the taper roller bearing.

ST 498077000 REMOVER

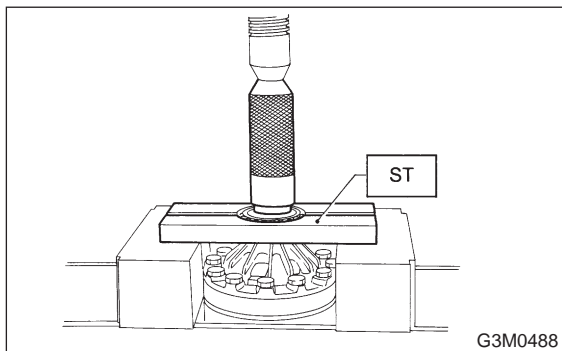

2) Secure the case in a vise and remove the crown gear tightening bolts, then separate the crown gear, case (RH) and case (LH).

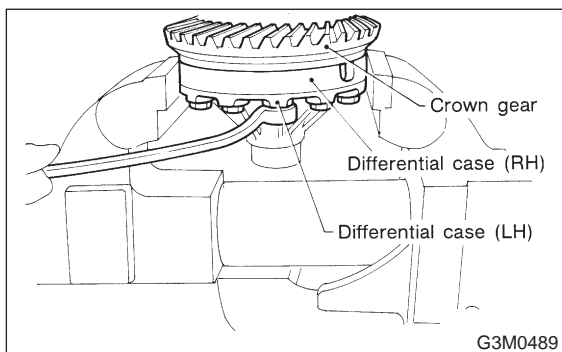

3) Pull out the straight pin and shaft, and remove the differential bevel gear, washer, and differential bevel pinion.

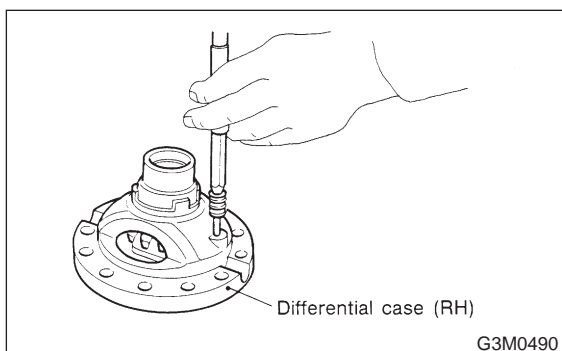

B: INSPECTION

Check each component for harmful cuts, damage and other faults.

C: ASSEMBLY

1) Install the washer, differential bevel gear and differential bevel pinion in the differential case (RH). Insert the pinion shaft, and fit the straight pin.

NOTE:

Install straight pin from reverse direction.

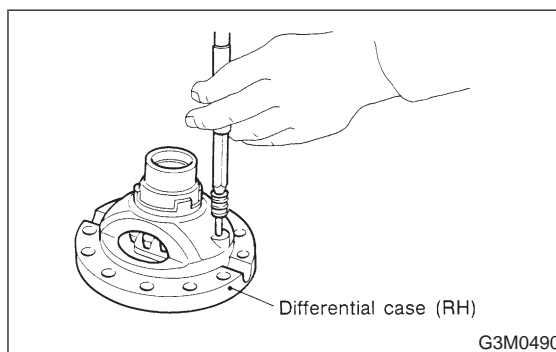

2) Install the washer and differential bevel gear to the differential case (LH). Then put the case over the differential case (RH), and connect both cases.

3) Install the crown gear and secure by tightening the bolt.

Standard tightening torque:

62±5 N·m (6.3±0.5 kg·m, 45.6±3.6 ft·lb)

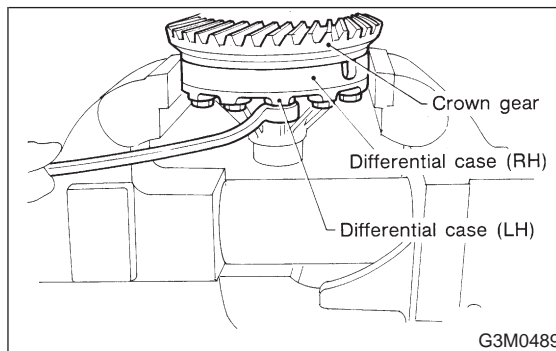

- 4) Measurement of backlash (Selection of washer)
Measure the gear backlash with ST1 and ST2, and insert ST2 through the access window of the case.
ST1 498247001 MAGNET BASE
ST2 498247100 DIAL GAUGE

NOTE:

Measure the backlash by applying a pinion tooth between two bevel gear teeth.

Standard value:

0.13 — 0.18 mm (0.0051 — 0.0071 in)

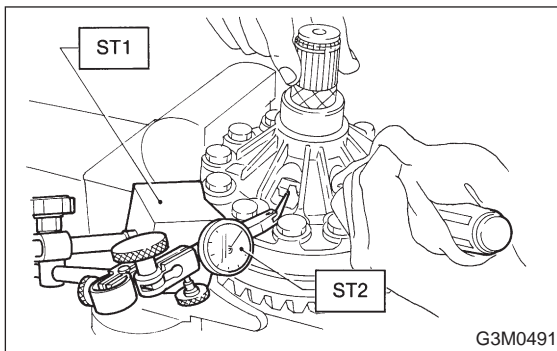

- 5) Using ST, install taper roller bearing.
ST 398487700 DRIFT

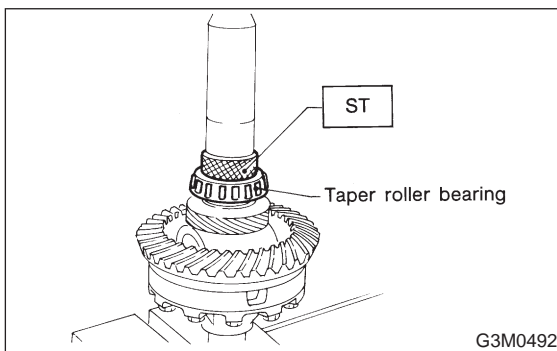

20. Transfer Clutch

A: DISASSEMBLY

- 1) Remove the seal ring.

CAUTION:

Be careful not to damage the seal ring.

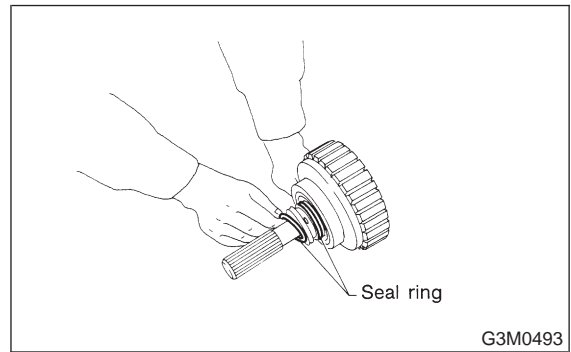

- 2) Using a press and ST, remove the ball bearing.

CAUTION:

Do not reuse the bearing.

ST 498077600 REMOVER

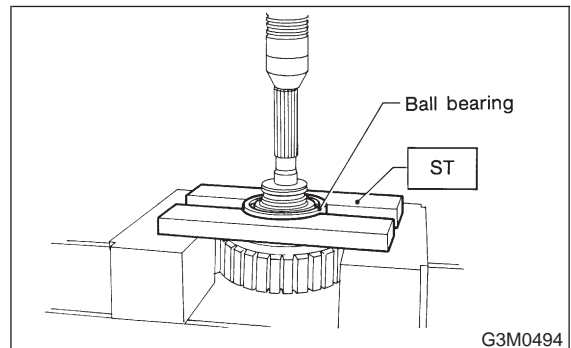

- 3) Remove the snap ring, and take out the pressure plate, drive plates, and driven plates.

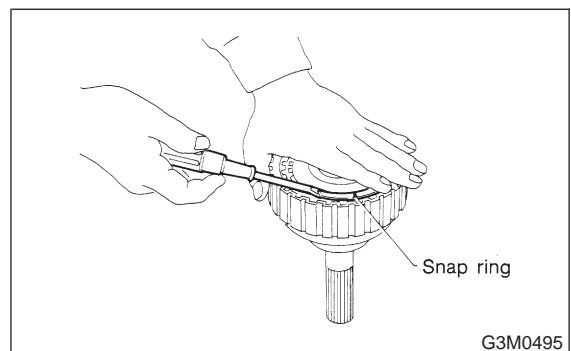

- 4) Measurement of backlash (Selection of washer)
Measure the gear backlash with ST1 and ST2, and insert ST2 through the access window of the case.
ST1 498247001 MAGNET BASE
ST2 498247100 DIAL GAUGE

NOTE:

Measure the backlash by applying a pinion tooth between two bevel gear teeth.

Standard value:

0.13 — 0.18 mm (0.0051 — 0.0071 in)

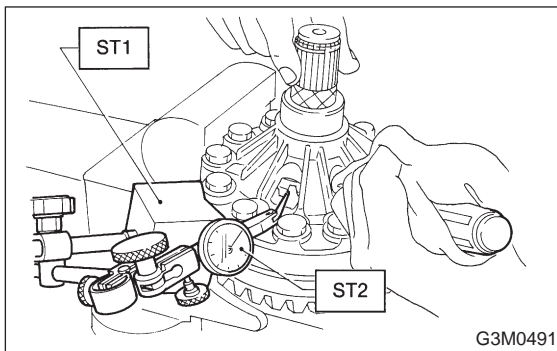

- 5) Using ST, install taper roller bearing.
ST 398487700 DRIFT

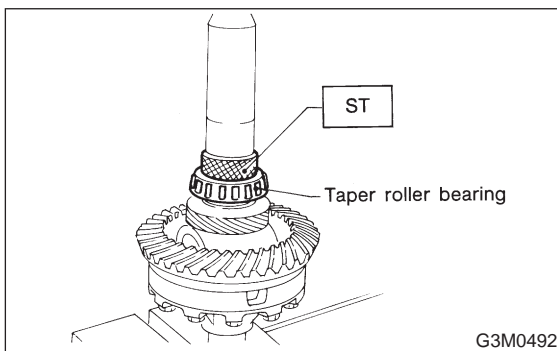

20. Transfer Clutch

A: DISASSEMBLY

- 1) Remove the seal ring.

CAUTION:

Be careful not to damage the seal ring.

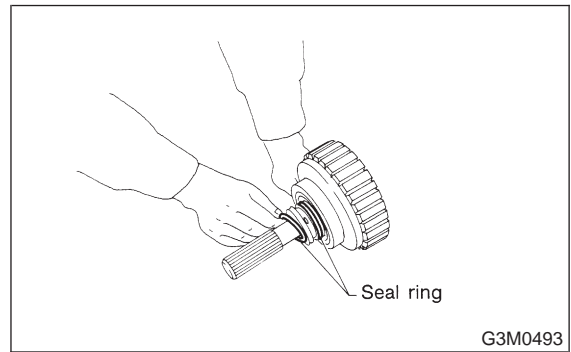

- 2) Using a press and ST, remove the ball bearing.

CAUTION:

Do not reuse the bearing.

ST 498077600 REMOVER

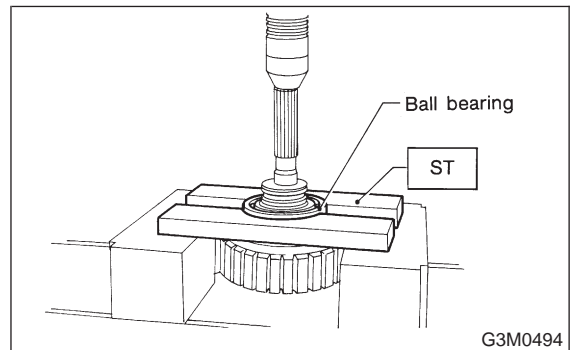

- 3) Remove the snap ring, and take out the pressure plate, drive plates, and driven plates.

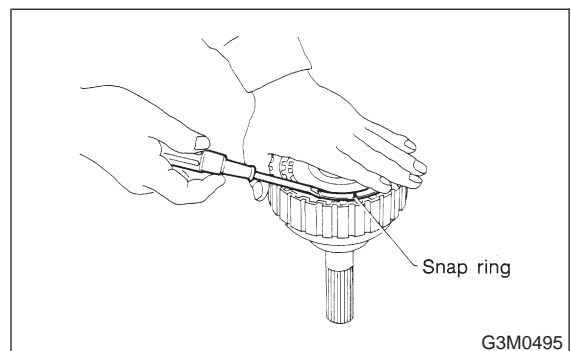

3-2 [W20B0]

20. Transfer Clutch

SERVICE PROCEDURE

4) Remove the snap ring with ST1, ST2 and ST3, and take out the return spring and transfer clutch piston seal.

ST1 399893600 PLIERS
ST2 398673600 COMPRESSOR
ST3 398623600 SEAT

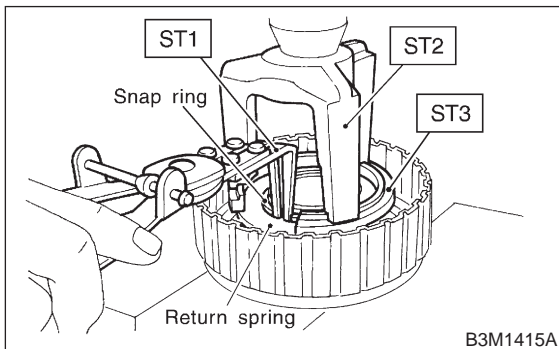

5) Apply compressed air to the rear drive shaft to remove the piston.

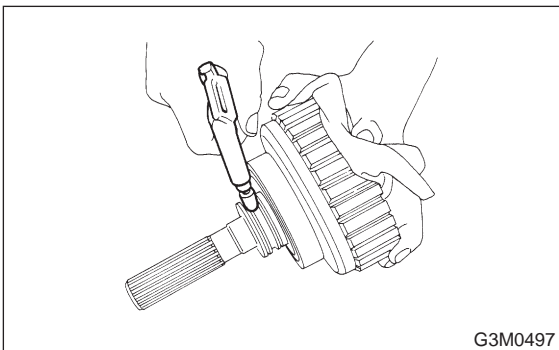

B: INSPECTION

- 1) Check the drive plate facing for wear and damage.
- 2) Check the snap ring for wear, return spring for permanent set and breakage, and return spring for deformation.
- 3) Check the lathe cut ring for damage.

C: ASSEMBLY

1) Install the transfer clutch piston.

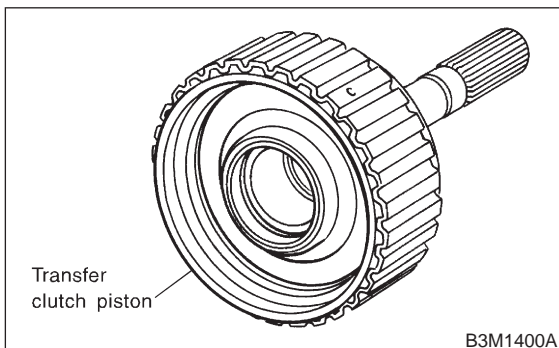

2) Install return spring to transfer piston.

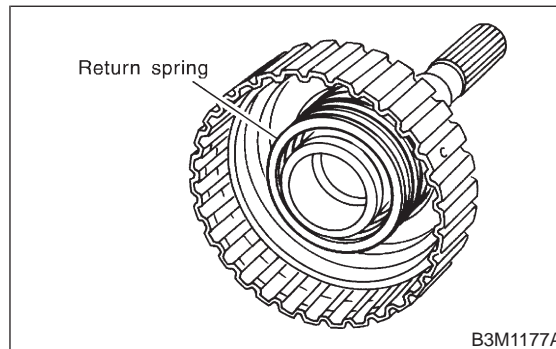

3) Install transfer clutch piston seal.

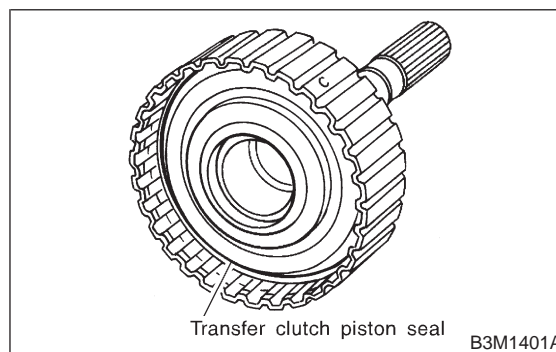

4) Install ST to rear drive shaft.

ST 499257300 SNAP RING OUTER GUIDE

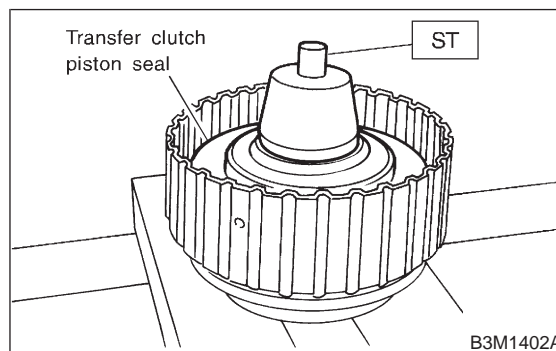

5) Install snap ring to ST.

ST 499257300 SNAP RING OUTER GUIDE

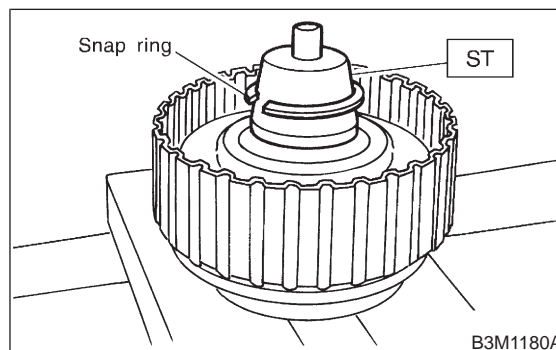

6) Using ST1 and ST2, install snap ring to rear drive shaft.

NOTE:

After installing snap ring, remove ST1 and ST2.

ST1 499257300 SNAP RING OUTER GUIDE

ST2 499247400 INSTALLER

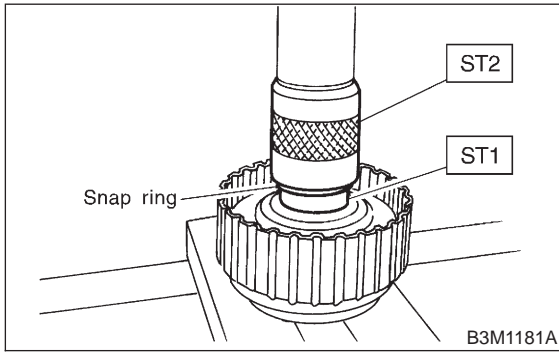

7) Install the driven plates, drive plates, pressure plate and snap ring.

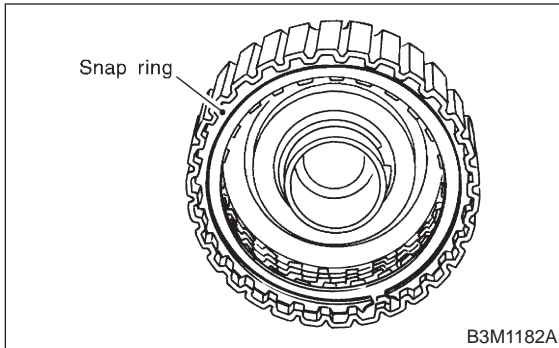

8) Apply compressed air to see if the assembled parts move smoothly.

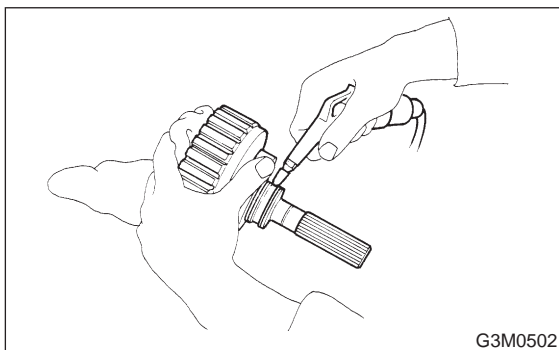

9) Check the clearance.

NOTE:

Before measuring clearance, place the same thickness of shim on both sides to prevent pressure plate from tilting.

If the clearance is not within the specified range, select a proper pressure plate.

Standard value:

0.2 — 0.6 mm (0.008 — 0.024 in)

Allowable limit:

1.6 mm (0.063 in)

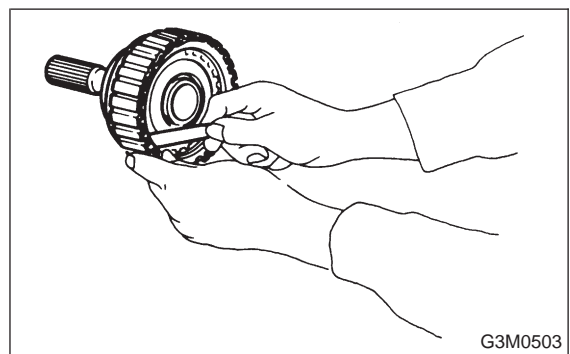

Available pressure plates	
Part No.	Thickness mm (in)
31593AA151	3.3 (0.130)
31593AA161	3.7 (0.146)
31593AA171	4.1 (0.161)
31593AA181	4.5 (0.177)

10) Press-fit the ball bearing with ST.

ST 899580100 INSTALLER

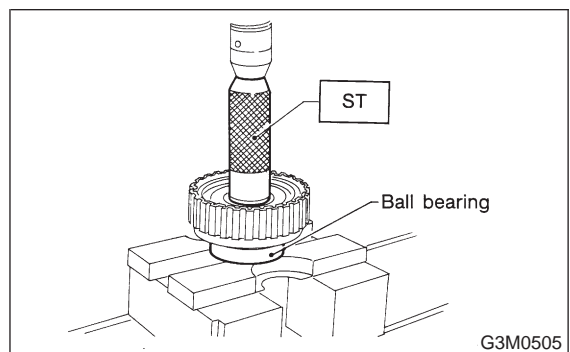

3-2 [W21A0]

21. Transfer Valve Body

SERVICE PROCEDURE

11) Coat the seal ring with vaseline, and install it in the seal ring groove of the shaft.

CAUTION:

Do not expand the seal ring excessively when installing.

ST 899580100 INSTALLER

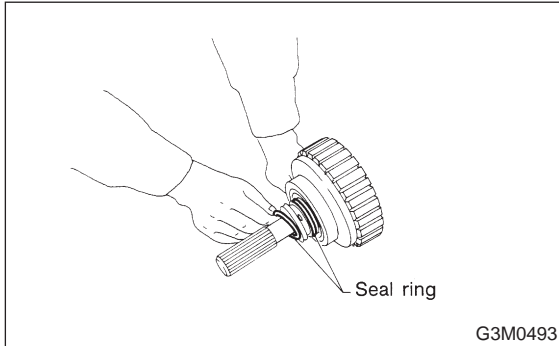

21. Transfer Valve Body

A: DISASSEMBLY

- 1) Separate duty solenoid C (transfer) and transfer valve body.
- 2) Remove the stopper plate and pry out the plug with a screwdriver. Then extract the spring and transfer control valve together.

CAUTION:

Be careful not to damage the valve and valve body.

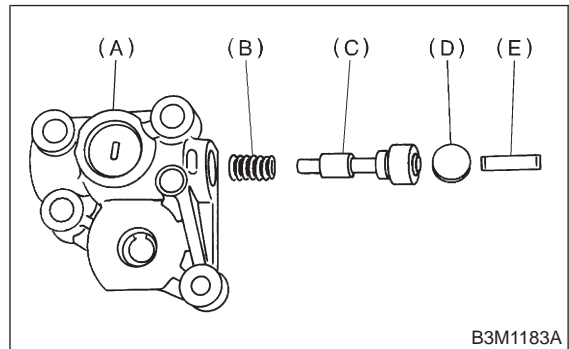

- (A) Transfer valve body
- (B) Return spring
- (C) Transfer control valve
- (D) Plug
- (E) Stopper plate

B: INSPECTION

Check each component for harmful cuts, damage, or other faults.

C: ASSEMBLY

To assemble, reverse the removal sequence.

NOTE:

Make sure the valve slides smoothly after assembling.

3-2 [W21A0]

21. Transfer Valve Body

SERVICE PROCEDURE

11) Coat the seal ring with vaseline, and install it in the seal ring groove of the shaft.

CAUTION:

Do not expand the seal ring excessively when installing.

ST 899580100 INSTALLER

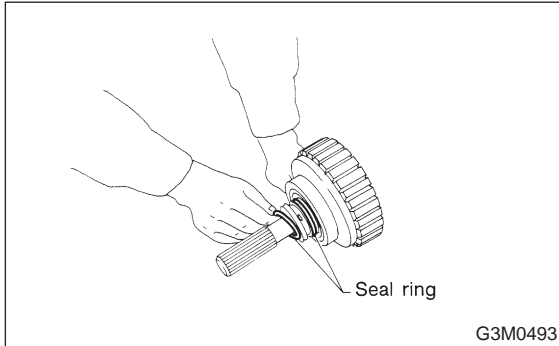

21. Transfer Valve Body

A: DISASSEMBLY

- 1) Separate duty solenoid C (transfer) and transfer valve body.
- 2) Remove the stopper plate and pry out the plug with a screwdriver. Then extract the spring and transfer control valve together.

CAUTION:

Be careful not to damage the valve and valve body.

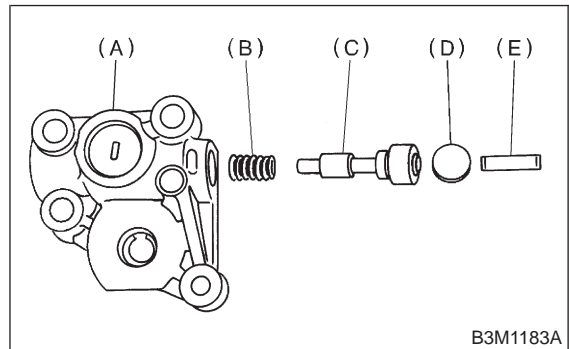

- (A) Transfer valve body
- (B) Return spring
- (C) Transfer control valve
- (D) Plug
- (E) Stopper plate

B: INSPECTION

Check each component for harmful cuts, damage, or other faults.

C: ASSEMBLY

To assemble, reverse the removal sequence.

NOTE:

Make sure the valve slides smoothly after assembling.

22. Transmission Control Module

A: REMOVAL

1. LHD

- 1) Disconnect battery ground cable.

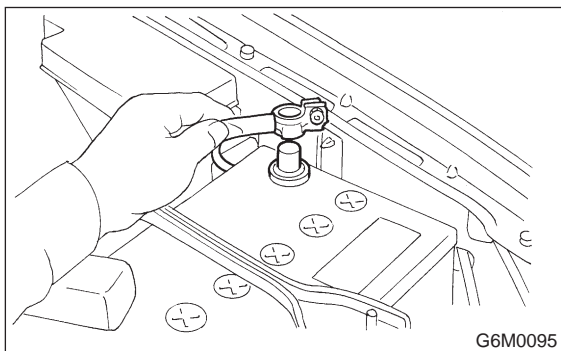

G6M0095

- 2) Remove lower cover and then disconnect connector.

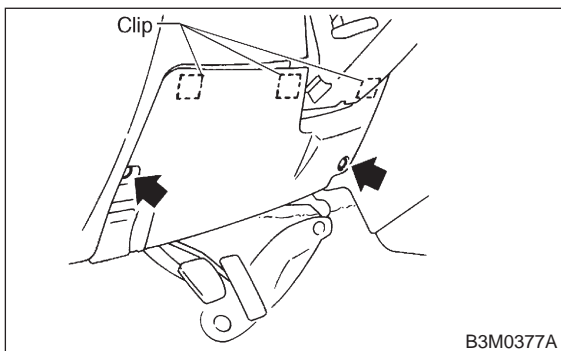

B3M0377A

- 3) Remove transmission control module.

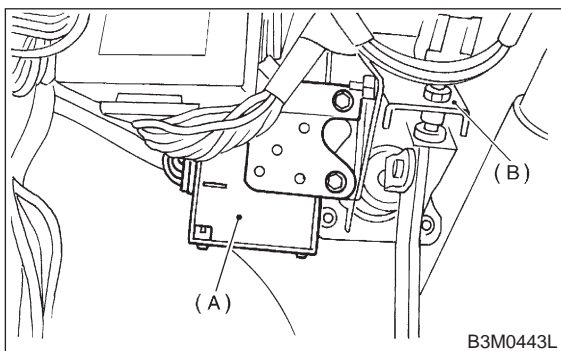

B3M0443L

- (A) Transmission control module
- (B) Pedal bracket

- 4) Disconnect connectors form TCM.

2. RHD

- 1) Disconnect battery ground cable.

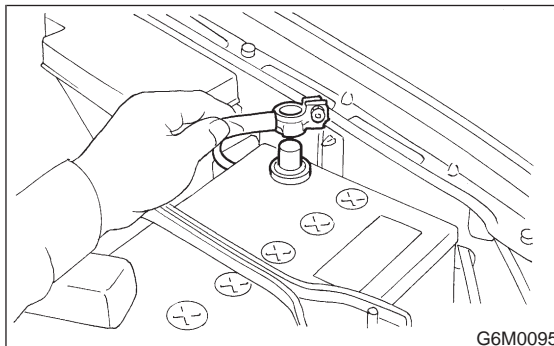

G6M0095

- 2) Remove lower cover and then disconnect connector.
- 3) Remove transmission control module.

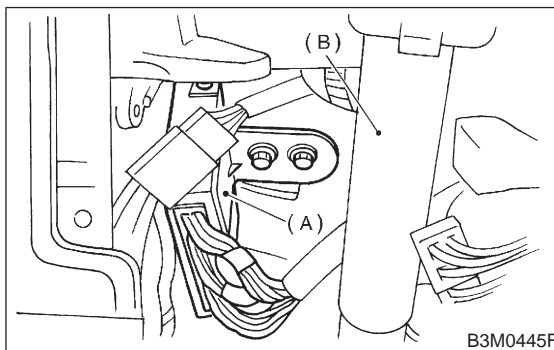

B3M0445F

- (A) Transmission control module
- (B) Column shaft

- 4) Disconnect connectors from transmission control module.

B: INSTALLATION

1. LHD

- 1) Connect connectors to TCM.
- 2) Install TCM to steering support beam.

Tightening torque:

7.4±2.0 N·m (0.75±0.2 kg·m, 5.4±1.4 ft·lb)

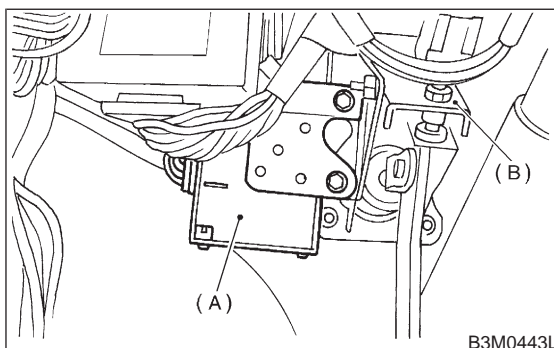

B3M0443L

- (A) Transmission control module
- (B) Pedal bracket

3-2 [W22B2]

23. Dropping Resistor

SERVICE PROCEDURE

3) Remove TCM from steering support beam.

2. RHD

1) Connect connectors to transmission control module.

2) Install transmission control module.

Tightening torque:

25 ± 5 N·m (2.5 ± 0.5 kg·m, 18.1 ± 3.6 ft·lb)

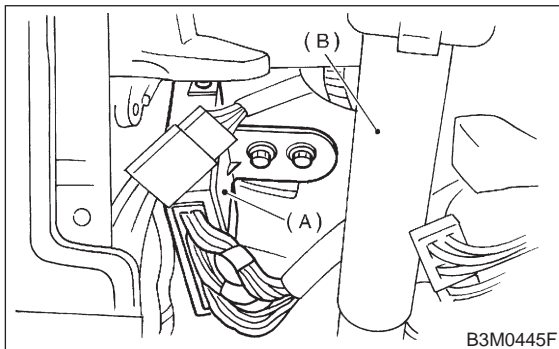

- (A) Transmission control module
(B) Column shaft

3) Installing procedure hereafter is in the reverse order of removal.

23. Dropping Resistor

A: REMOVAL AND INSTALLATION

1) Disconnect battery ground cable.

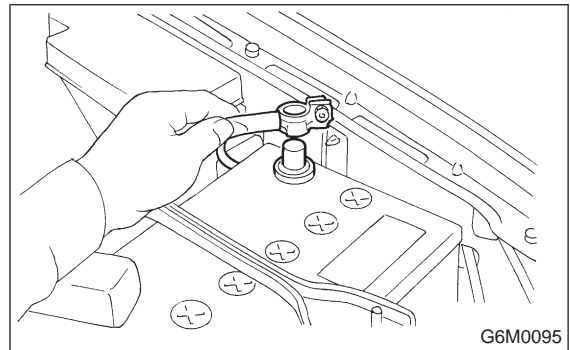

- 2) Remove air intake duct. <Ref. to 2-7 [W1A0].>
3) Disconnect connector from dropping resistor.
4) Remove dropping resistor from bracket.

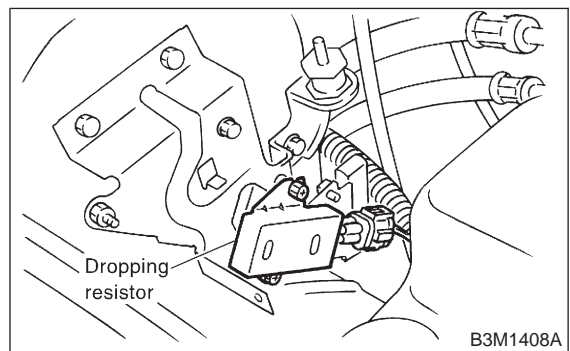

5) Installation is in the reverse order of removal.

Tightening torque:

6.4 ± 0.5 N·m (0.65 ± 0.05 kg·m, 4.7 ± 0.4 ft·lb)

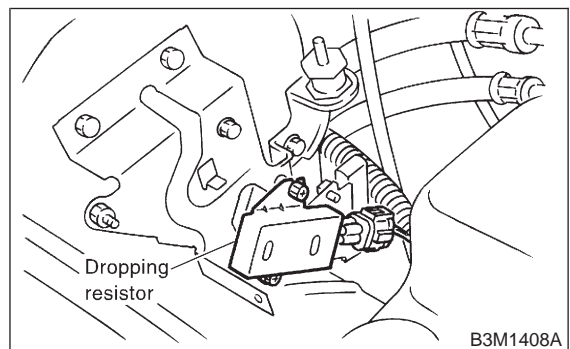

3-2 [W22B2]

23. Dropping Resistor

SERVICE PROCEDURE

3) Remove TCM from steering support beam.

2. RHD

1) Connect connectors to transmission control module.

2) Install transmission control module.

Tightening torque:

25 ± 5 N·m (2.5 ± 0.5 kg·m, 18.1 ± 3.6 ft·lb)

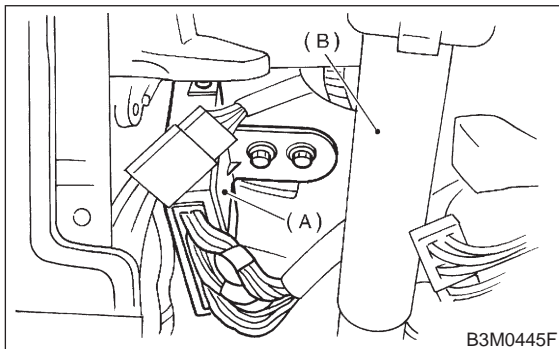

- (A) Transmission control module
(B) Column shaft

3) Installing procedure hereafter is in the reverse order of removal.

23. Dropping Resistor

A: REMOVAL AND INSTALLATION

1) Disconnect battery ground cable.

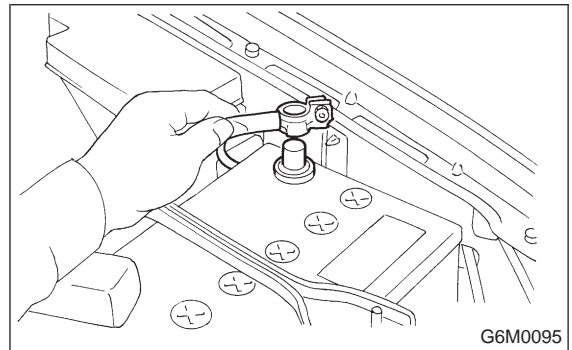

- 2) Remove air intake duct. <Ref. to 2-7 [W1A0].>
3) Disconnect connector from dropping resistor.
4) Remove dropping resistor from bracket.

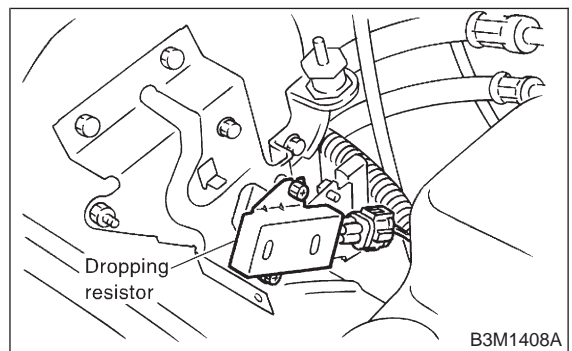

5) Installation is in the reverse order of removal.

Tightening torque:

6.4 ± 0.5 N·m (0.65 ± 0.05 kg·m, 4.7 ± 0.4 ft·lb)

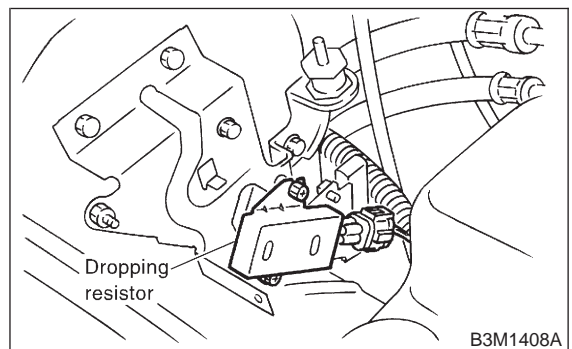

1. Manual Transmission

A: AWD MODEL

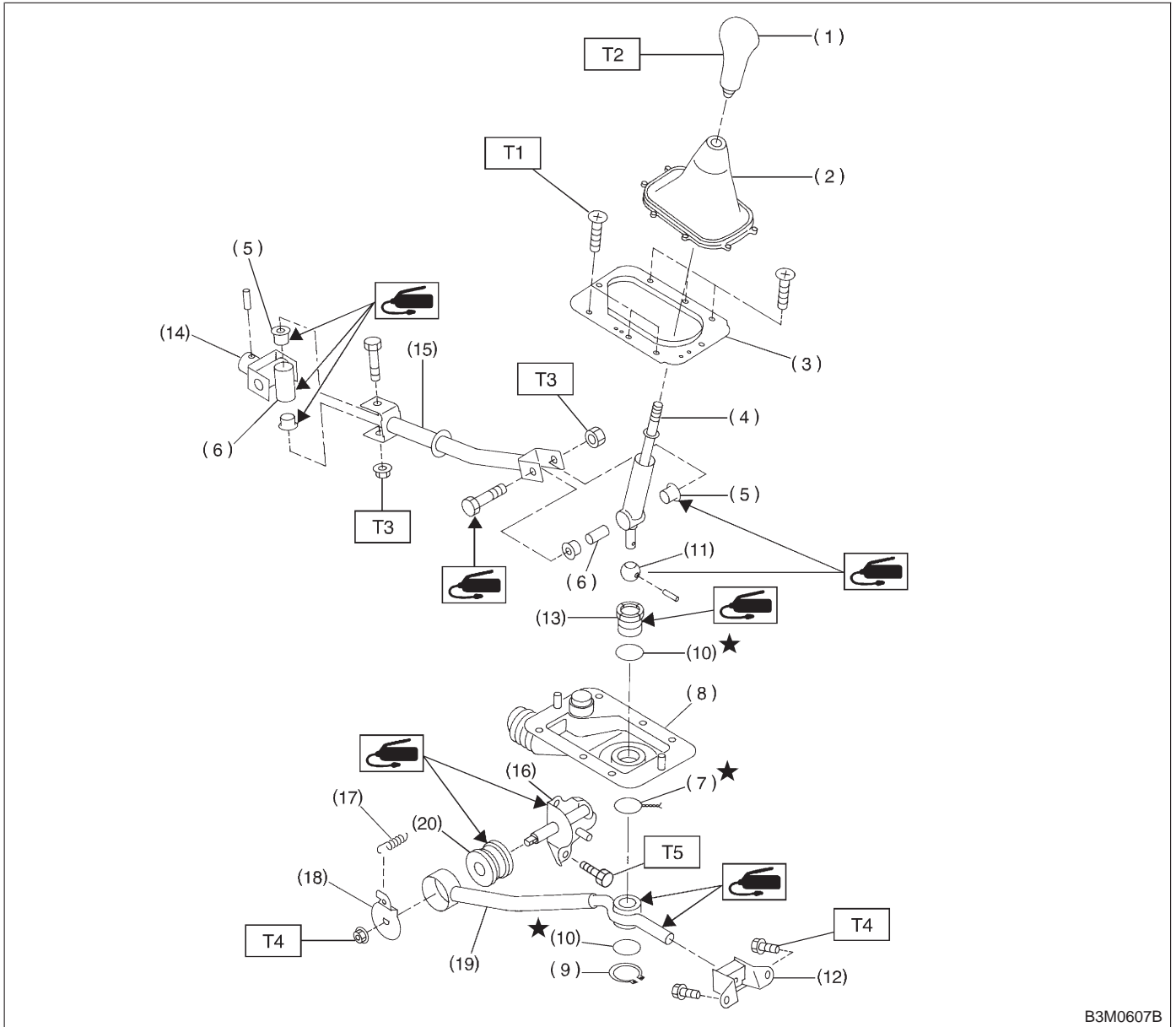

B3M0607B

- | | |
|----------------------|-------------------------|
| (1) Gear shift knob | (11) Bush (Shift lever) |
| (2) Console boot | (12) Cushion rubber |
| (3) Boot plate | (13) Bush (Stay rear) |
| (4) Gear shift lever | (14) Joint |
| (5) Bush | (15) Rod |
| (6) Spacer | (16) Bracket |
| (7) Locking wire | (17) Spring |
| (8) Boot | (18) Washer |
| (9) Snap ring | (19) Stay |
| (10) O-ring | (20) Bush (Stay front) |

Tightening torque: N·m (kg-m, ft-lb)

T1: 4.4±1.5 (0.45±0.15, 3.3±1.1)

T2: 5 (0.51, 3.7)

T3: 12±3 (1.2±0.3, 8.7±2.2)

T4: 18±5 (1.8±0.5, 13.0±3.6)

**T5: 24.5±2 (2.50±0.20,
18.07±1.48)**

2. Automatic Transmission

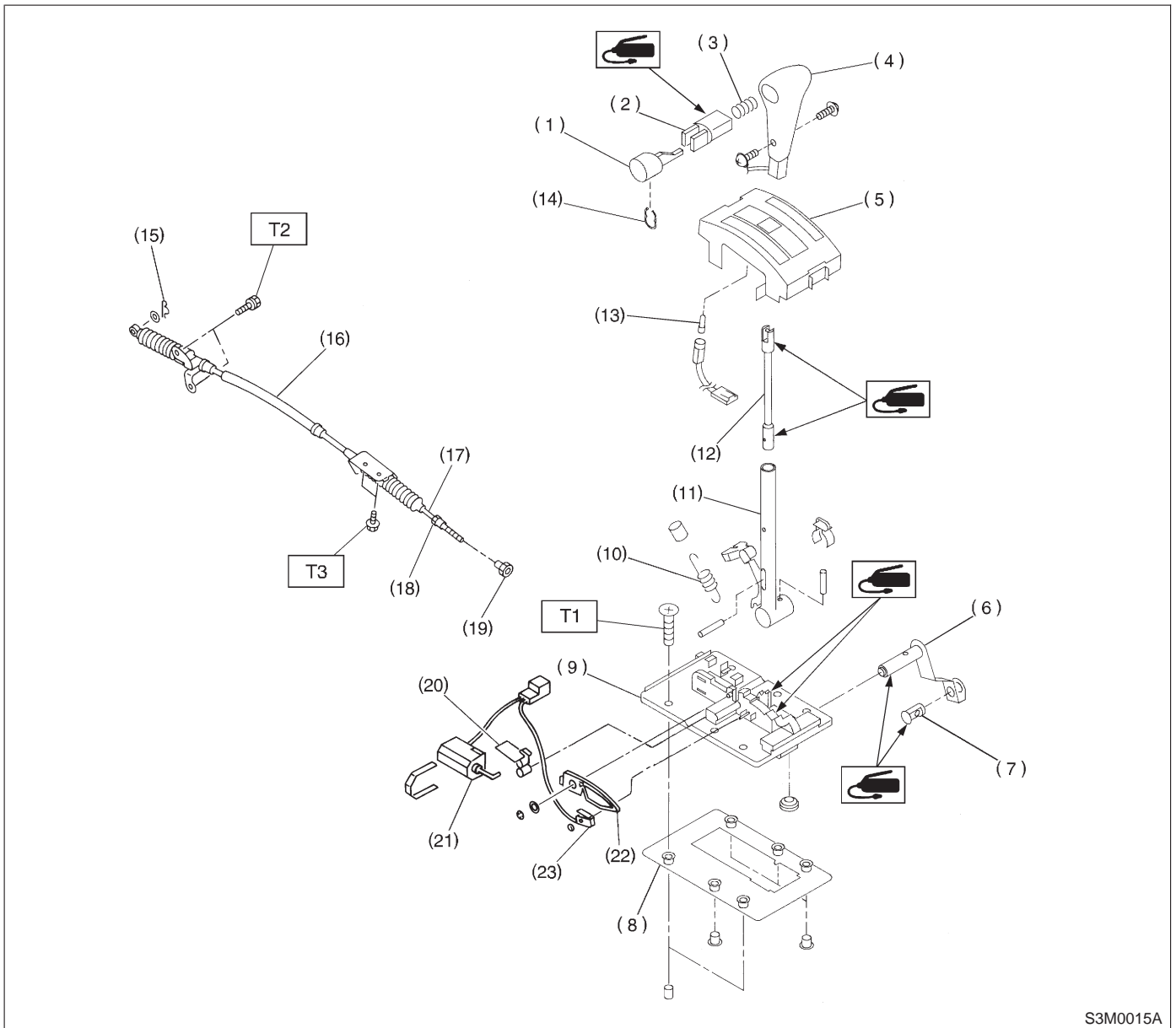

- | | | |
|--------------------------|---------------------------|--------------------------|
| (1) Button A | (11) Selector lever upper | (21) Shift-lock solenoid |
| (2) Button B | (12) Rod | (22) Lock arm |
| (3) Spring (button) | (13) Indicator light bulb | (23) "P" position switch |
| (4) Grip | (14) Retainer spring | |
| (5) Indicator cover | (15) Snap pin | |
| (6) Selector lever lower | (16) Outer cable | |
| (7) Pin | (17) Inner cable | |
| (8) Packing | (18) Nut (front) | |
| (9) Plate | (19) Nut (rear) | |
| (10) Detent spring | (20) Lock plate | |

Tightening torque: N-m (kg-m, ft-lb)

T1: 5.9±1.5 (0.6±0.15, 4.3±1.1)

T2: 12±3 (1.2±0.3, 8.7±2.2)

T3: 25±7 (2.5±0.7, 18.1±5.1)

1. Manual Transmission

A: REMOVAL

- 1) Remove console box. <Ref. to 5-4 [W1A0].>
- 2) Remove boot plate from the body.

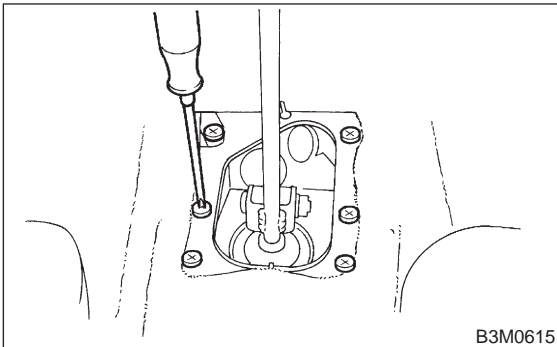

- 3) Remove the spring between the joint and bracket.

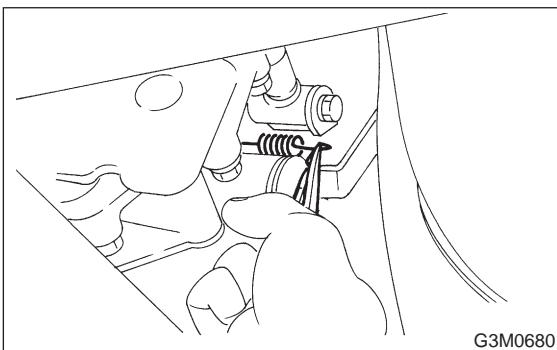

- 4) Remove stay from bracket.

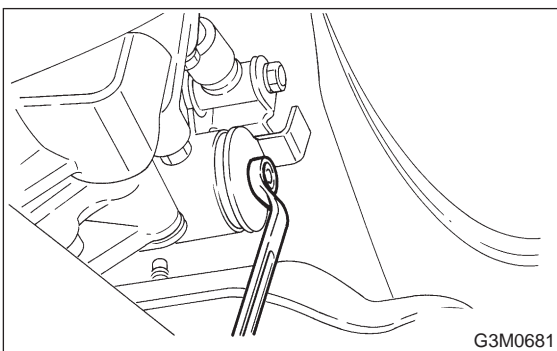

- 5) Remove rod from joint.

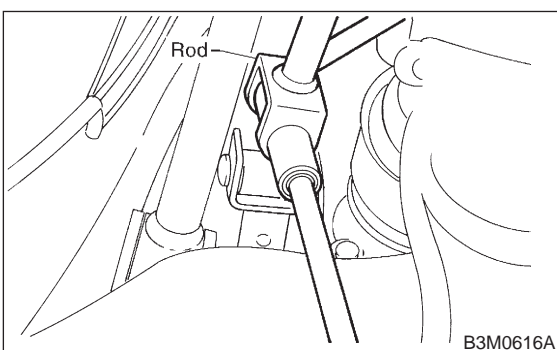

- 6) Remove gearshift lever.

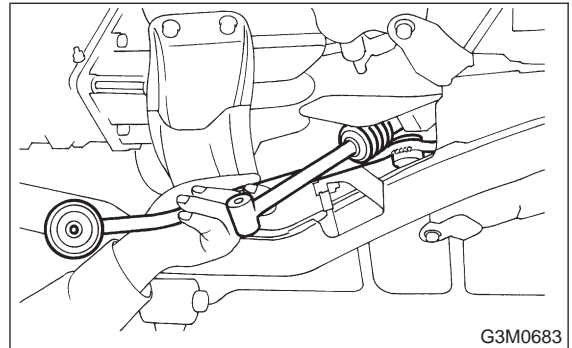

- 7) Remove the exhaust cover and remove cushion rubber from the body.

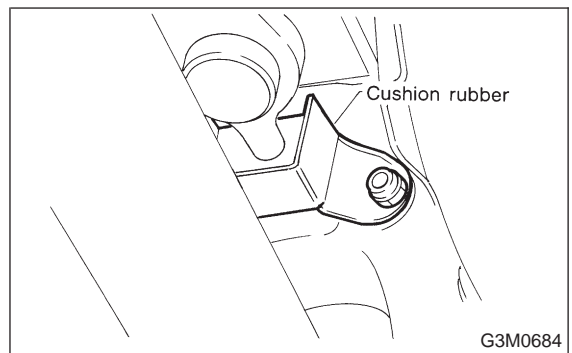

B: DISASSEMBLY

- 1) Disconnect locking wire.

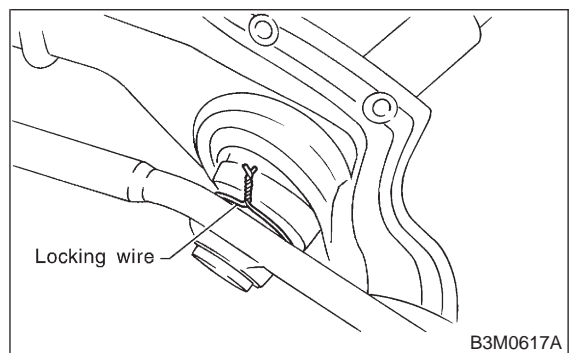

- 2) Remove rod from gearshift lever.

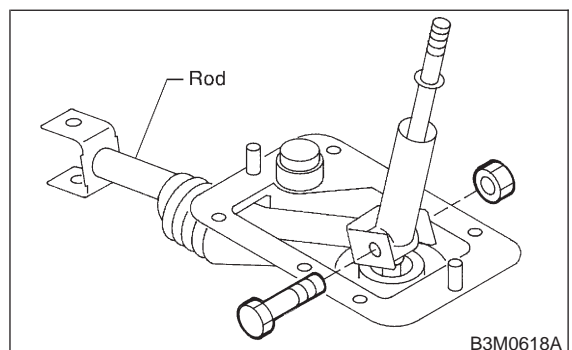

3-3 [W1C0]

1. Manual Transmission

SERVICE PROCEDURE

- 3) Remove snap ring, then disconnect gearshift lever from stay.
- 4) Remove boot from gearshift lever.

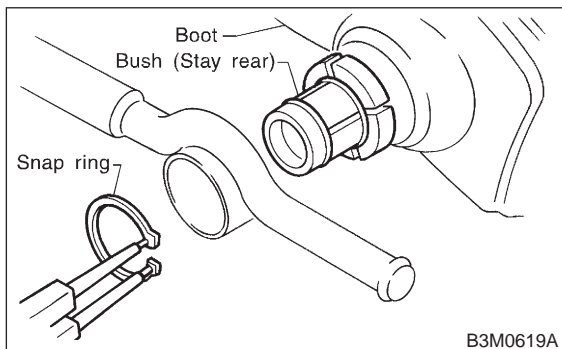

- 5) Remove O-ring, then disconnect bush (Stay rear).

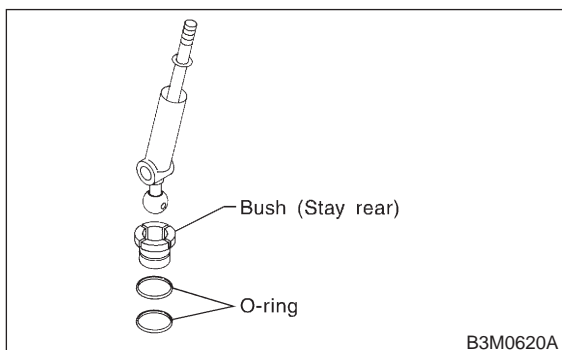

- 6) Draw out spring pin, then remove bush (Shift lever) from gearshift lever.

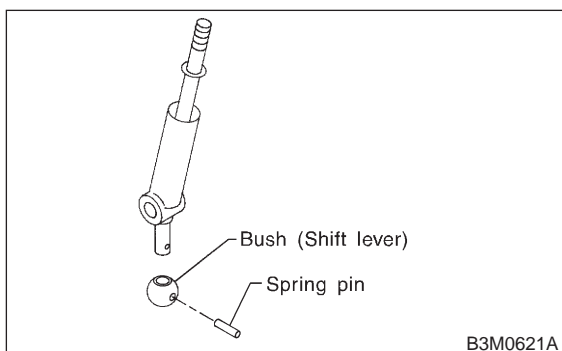

C: INSPECTION

Check each parts (Bush, cushion, spacer, boot, spring, stay and rod etc.) for deformation, damage and wear. Repair or replace any defective parts. Determine defective parts by comparing with new parts.

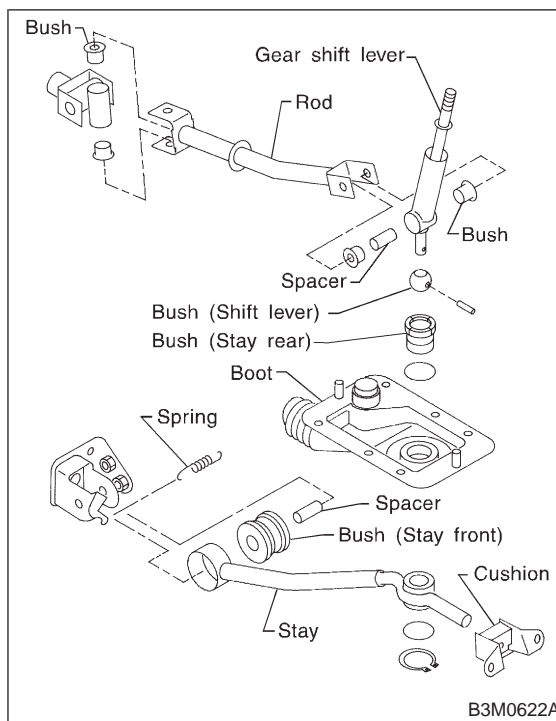

D: ASSEMBLY

- 1) Clean all parts before assembly.
- 2) Mount the following parts on the stay.

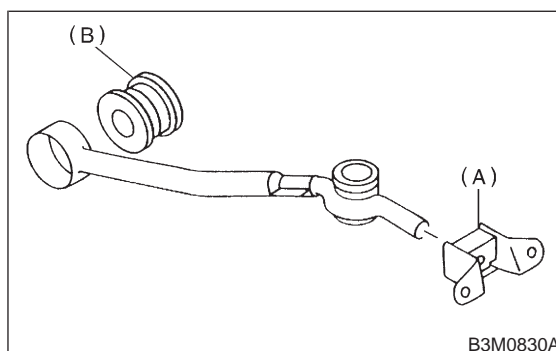

- (A) Cushion rubber
(B) Bush (Stay front)

3) Mount each parts (Boot, O-ring, bush and spacer) on the gearshift lever.

CAUTION:

- Always use new O-rings.
- Apply grease [NIGTIGHT LYW No.2 or equivalent] to the inner and side surfaces of the bush when installing spacer.

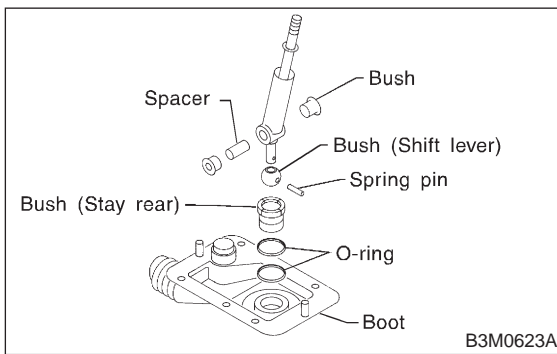

- 4) Insert the gearshift lever into the boot hole.
- 5) Mount gearshift lever on the stay.
- 6) Install snap ring to the bottom of the bush (Stay rear).

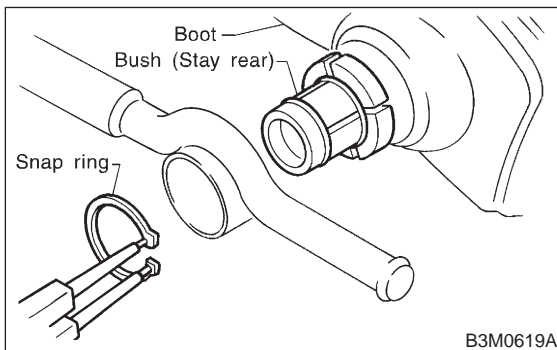

7) Tighten with locking wire to the extent that the boot will not come off.

CAUTION:

Always use new locking wire.

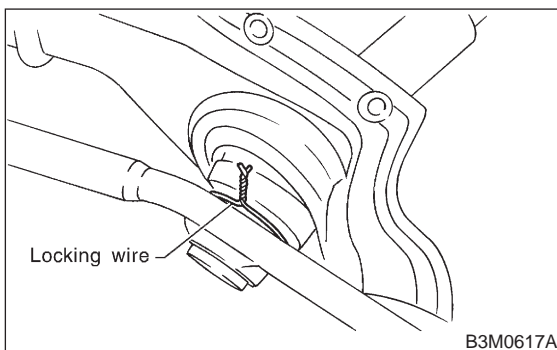

8) Insert the rod into the boot hole.

9) Connect rod to gearshift lever.

Tightening torque:

$12 \pm 3 \text{ N}\cdot\text{m}$ ($1.2 \pm 0.3 \text{ kg}\cdot\text{m}$, $8.7 \pm 2.2 \text{ ft}\cdot\text{lb}$)

Rocking torque:

$0.74 \pm 0.25 \text{ N}\cdot\text{m}$ ($0.075 \pm 0.025 \text{ kg}\cdot\text{m}$, $0.54 \pm 0.18 \text{ ft}\cdot\text{lb}$) or less

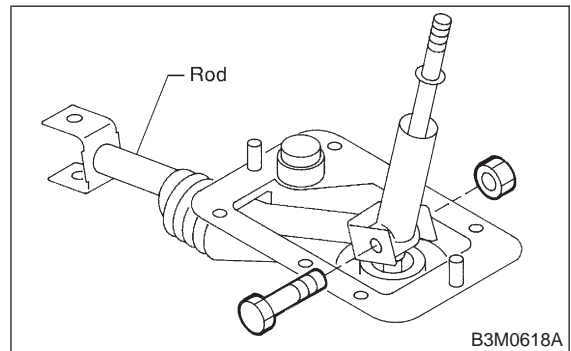

10) Check that there is no excessive play and that parts move smoothly.

E: INSTALLATION

- 1) Put into gearshift lever from passenger compartment.
- 2) Mount boot plate on the body.
- 3) Install console box and gearshift knob. <Ref. to 5-4 [W1B0].>

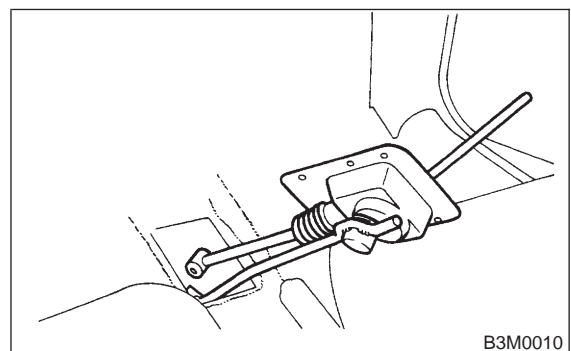

4) Mount cushion rubber on the body.

Tightening torque:

$18 \pm 5 \text{ N}\cdot\text{m}$ ($1.84 \pm 0.51 \text{ kg}\cdot\text{m}$, $13.3 \pm 3.7 \text{ ft}\cdot\text{lb}$)

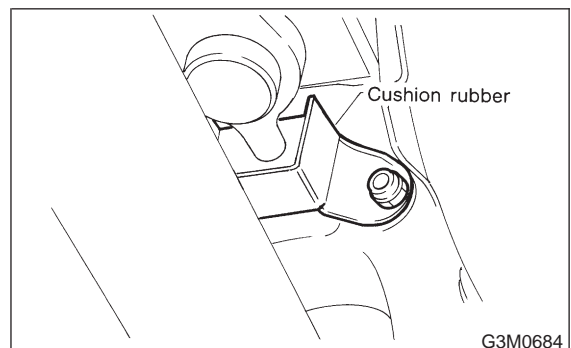

3-3 [W2A0]

2. Automatic Transmission

SERVICE PROCEDURE

5) Connect rod to the joint.

Tightening torque:

FWD model

12 ± 3 N·m (1.2 ± 0.3 kg·m, 8.7 ± 2.2 ft·lb)

AWD model

18 ± 5 N·m (1.84 ± 0.51 kg·m, 13.3 ± 3.7 ft·lb)

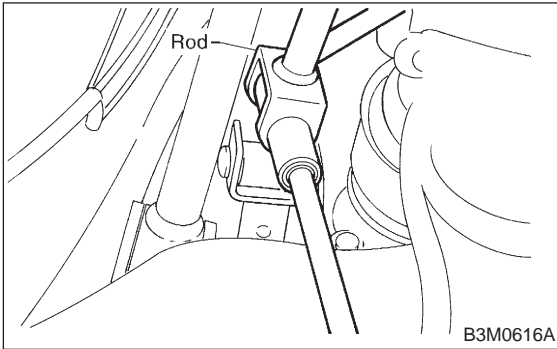

6) Connect stay to the bracket.

Tightening torque:

18 ± 5 N·m (1.84 ± 0.51 kg·m, 13.3 ± 3.7 ft·lb)

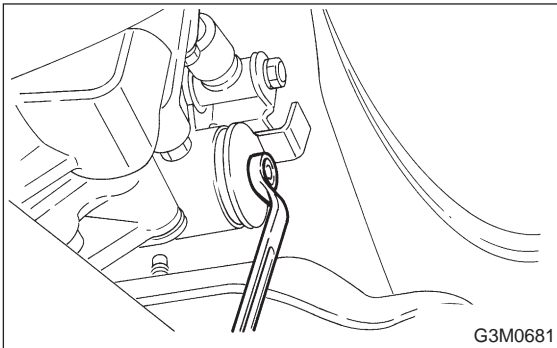

7) Install the exhaust cover.

2. Automatic Transmission

A: REMOVAL

1) Remove the cable.

(1) Prior to removal, set lever to "N" position.

(2) Remove front exhaust pipe.

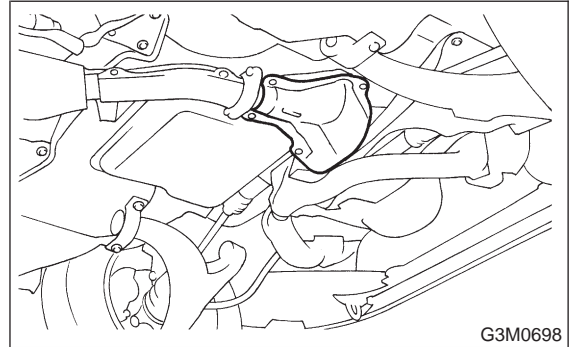

(3) Separate cable from transmission lever.

(4) Remove clamp from transmission case.

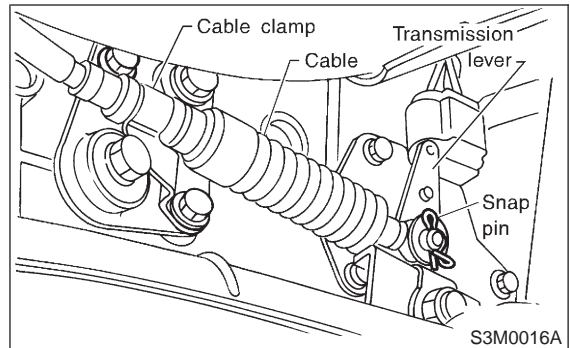

(5) Disconnect cable from selector lever and then remove cable bracket.

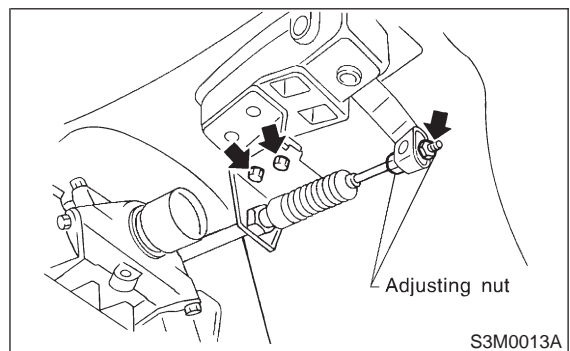

3-3 [W2A0]

2. Automatic Transmission

SERVICE PROCEDURE

5) Connect rod to the joint.

Tightening torque:

FWD model

12 ± 3 N·m (1.2 ± 0.3 kg·m, 8.7 ± 2.2 ft·lb)

AWD model

18 ± 5 N·m (1.84 ± 0.51 kg·m, 13.3 ± 3.7 ft·lb)

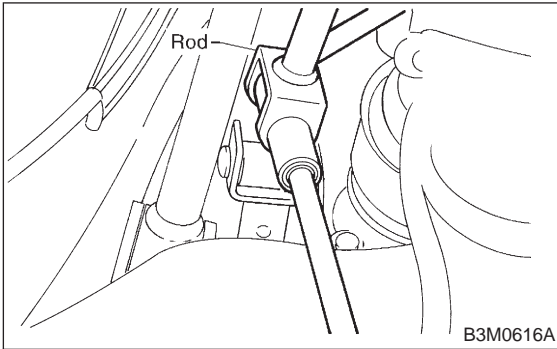

6) Connect stay to the bracket.

Tightening torque:

18 ± 5 N·m (1.84 ± 0.51 kg·m, 13.3 ± 3.7 ft·lb)

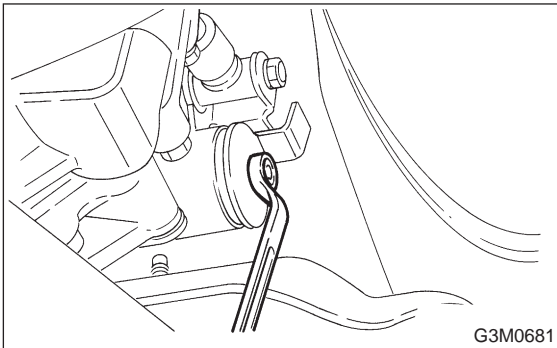

7) Install the exhaust cover.

2. Automatic Transmission

A: REMOVAL

1) Remove the cable.

(1) Prior to removal, set lever to "N" position.

(2) Remove front exhaust pipe.

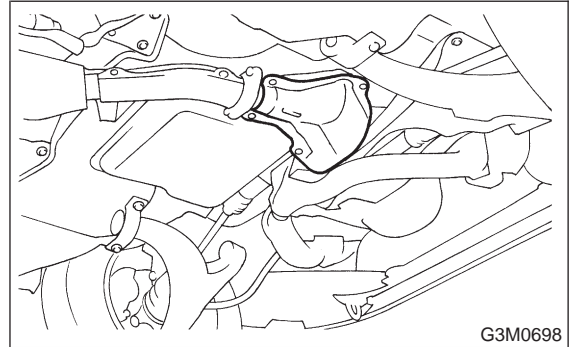

(3) Separate cable from transmission lever.

(4) Remove clamp from transmission case.

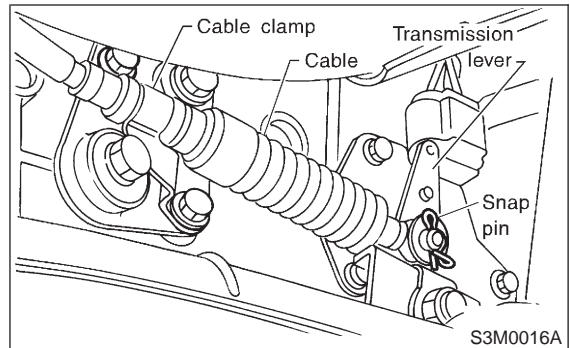

(5) Disconnect cable from selector lever and then remove cable bracket.

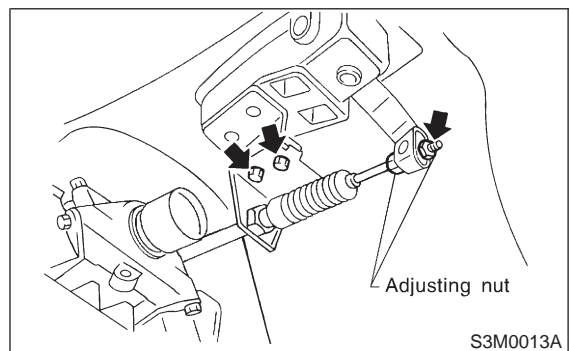

- 2) Remove console box. <Ref. to 5-4 [W1A0].>
- 3) Disconnect the connectors, then remove the six screws to take out the selector lever assembly from the body.

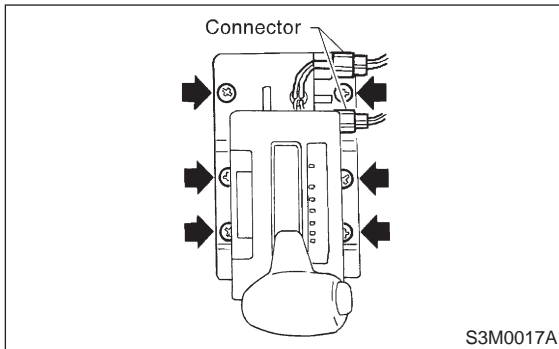

B: DISASSEMBLY

- 1) Remove connector from plate.

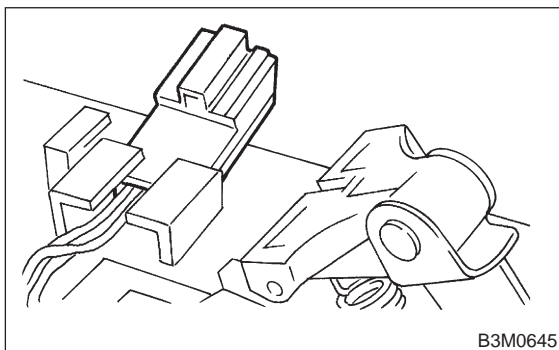

- 2) Remove indicator light and two screws.
- 3) Remove retainer spring, then pull up selector lever grip with indicator cover for holding selector lever button.

CAUTION:

Pull the selector lever grip carefully so that the selector lever button may not jump out.

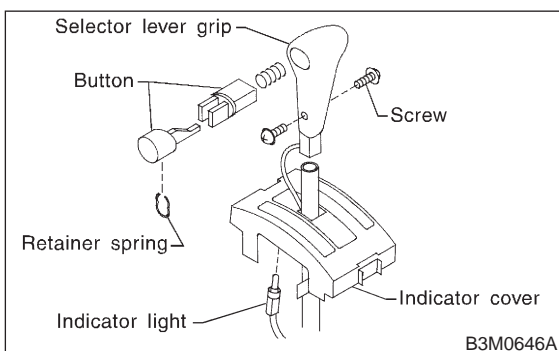

- 4) Remove shift-lock solenoid and "P" position switch.

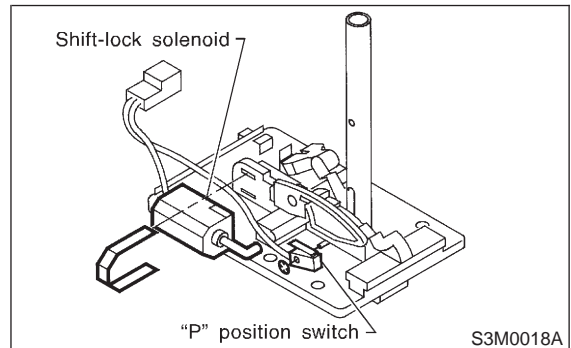

- 5) Remove cap and clip, then extract pin.
- 6) Remove selector lever lower then take away selector lever upper from plate.

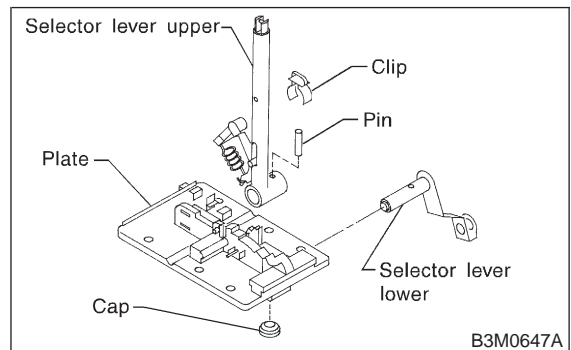

C: INSPECTION

- 1) Inspect removed parts by comparing with new ones for deformation, damage and wear. Correct or replace if defective.
- 2) Confirm the following parts for operating condition before assembly.
 - (1) Sliding condition of the button in the grip ... it should move smoothly.
 - (2) Insertion of the grip on the selector lever ... when pushing the grip on the selector lever by hand, screw holes should be aligned.
 - (3) Operation of selector lever and rod ... they should move smoothly.

D: ASSEMBLY

- 1) Clean all parts before assembly.
- 2) Apply grease [NIGHTIGHT LYW No. 2 or equivalent] to each parts. <Ref. to 3-3 [C200].>
- 3) Assembly is in the reverse order of disassembly.
- 4) After completion of fitting, transfer selector lever to range "P" — "1", pressing the button of the grip; then check whether the indicator and selector lever agree, whether the pointer and position mark agree and what the operating force is.

E: INSTALLATION

- 1) Mount the selector lever onto the vehicle body.
- 2) Tighten the six bolts to install the selector lever to the vehicle body, then connect connectors.

Tightening torque:

5.9±1.5 N-m (0.6±0.15 kg-m, 4.3±1.1 ft-lb)

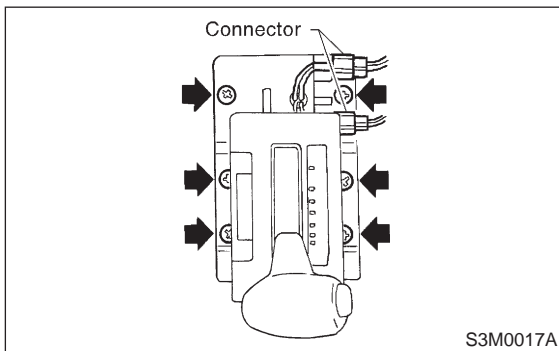

- 3) Install console box.
- 4) Set location of selector lever at "N" position.
- 5) Set location of selector arm installed on the transmission body at "N" position.

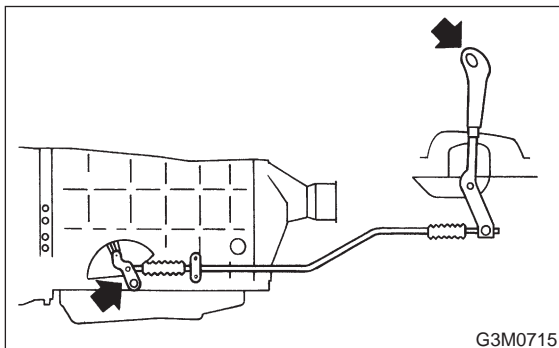

- 6) Pass inner cable through selector arm pin and then connect it using a washer and snap pin.
- 7) Attach outer cable to plate on transmission case with the bolts.

Tightening torque:

14±4 N-m (1.4±0.4 kg-m, 10.1±2.9 ft-lb)

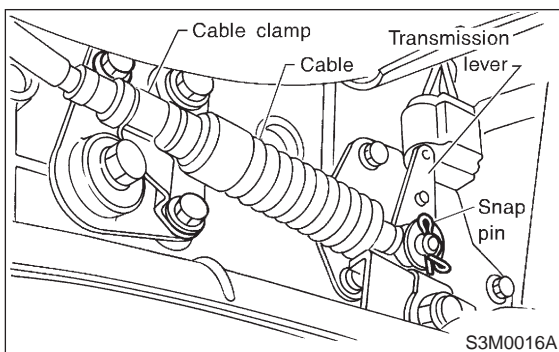

- 8) Insert the thread portion of the other inner cable and into the connector hole of the selector lever, and fix the other outer cable end to the bracket.
- 9) Adjust the inner cable length.

- (1) Put connector into contact with nut (A).
- (2) Tighten nut (B).

Tightening torque:

7.4±2.0 N-m (0.75±0.2 kg-m, 5.4±1.4 ft-lb)

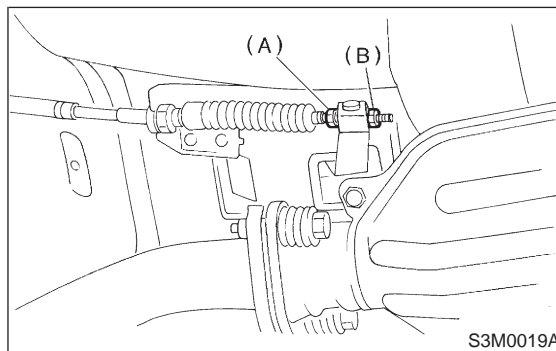

- 10) After completion of fitting, make sure that the selector lever operates smoothly all across the operating range.

- 11) Connect the harnesses and check the following items.

- (1) The engine starts operating when selector lever is in position "P", but not in other positions.
 - (2) The back-up light is lit when the selector lever is in position "R", but not in other positions.
- 12) Check selector lever operation.

WARNING:

Stop the engine while checking operation of selector lever.

- (1) Check that selector lever does not move from "N" to "R" without pushing the button.
- (2) Check that selector lever does not move from "R" to "P" without pushing the button.
- (3) Check that selector lever does not move from "P" to "R" without pushing the button.
- (4) Check that selector lever does not move from "3" to "2" without pushing the button.

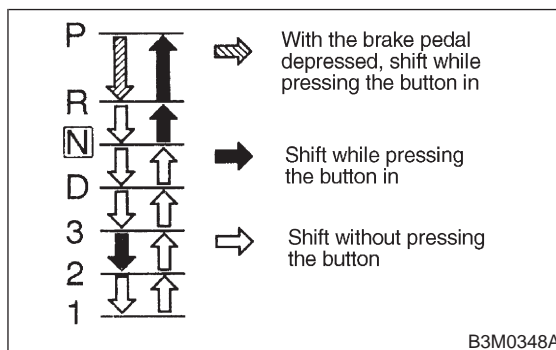

- 13) Check shift-lock system.

- (1) Ensure ignition switch rotates from "ACC" to "LOCK" when the selector lever is set at "P".

Also check that ignition key can be removed only from the "LOCK" position.

(2) Ensure selector lever moves from "P" to any other position when the brake pedal is

depressed with ignition key set at "ON" or "START".

MEMO:

1. Propeller Shaft

A: SPECIFICATIONS

Front propeller shaft Joint-to-joint length: L_1 mm (in)	AT	693 (27.28)
	MT	634 (24.96)
Rear propeller shaft Joint-to-joint length: L_2 mm (in)		768 (30.24)
Outside dia. of tube mm (in)	D_1	63.5 (2.500)
	D_2	57.0 (2.244)

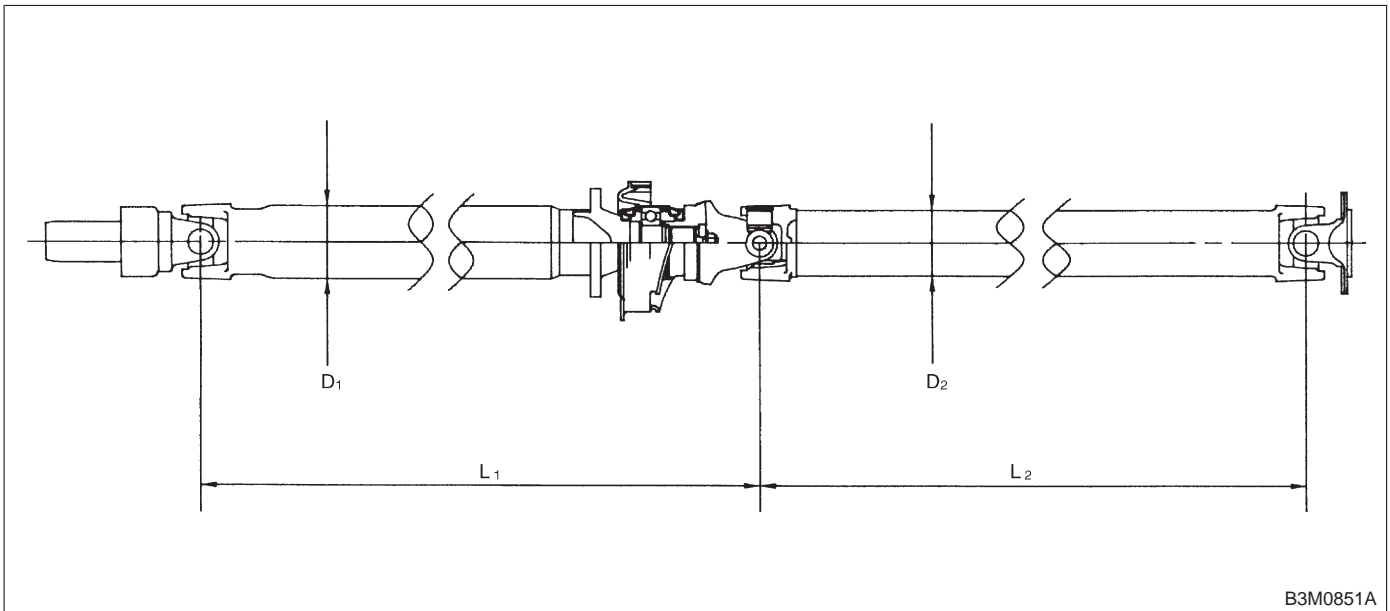

2. Rear Differential

A: SPECIFICATIONS

Type of gear	Hypoid			
	MT		AT	
	2200 cc	2500 cc	2200 cc	2500 cc
Gear ratio (Number of gear teeth)	3.900 (39/10)	4.111 (37/9)	4.111 (37/9)	4.444 (40/9)
Oil capacity	0.8 ℓ (0.8 US qt, 0.7 Imp qt)			
Rear differential gear oil	GL-5			

B: IDENTIFICATION

When replacing a rear differential assembly, select the correct one according to the following table.

CAUTION:

Using the different rear differential assembly causes the drive line and tires to “drag” or emit abnormal noise when AWD is selected.

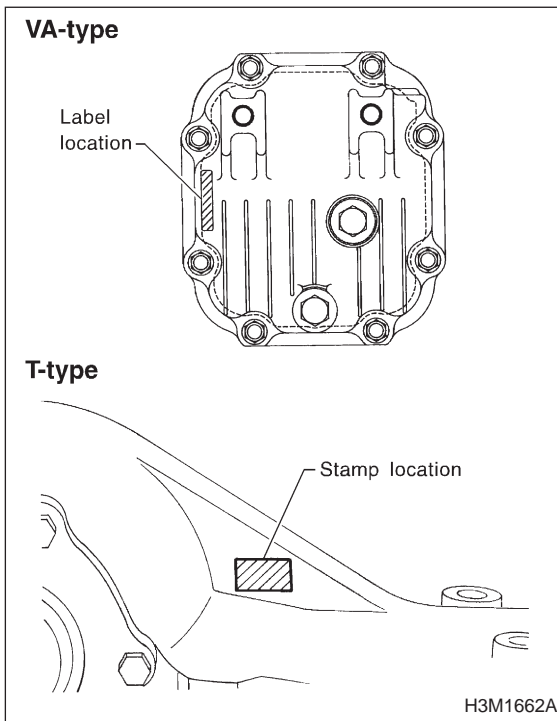



Gear ratio		Stamp or label on rear differential
2200 cc MT	3.900	<div style="border: 1px solid black; padding: 5px; display: inline-block;"> T 1 </div>
2200 cc AT	4.111	<div style="border: 1px solid black; padding: 5px; display: inline-block;"> VA1REF-XG </div>

B3M0124

H3M1159

3-4 [S2C1]
2. Rear Differential

SPECIFICATIONS AND SERVICE DATA

Gear ratio		Stamp or label on rear differential
2500 cc MT	4.111	 B3M0127
2500 cc AT	4.444	 B3M0421

C: ADJUSTING PARTS

1. REAR DIFFERENTIAL (T-TYPE)

Front and rear bearing preload at companion flange bolt hole	New bearing	19.6 — 28.4 N (2.0 — 2.9 kg, 4.4 — 6.4 lb)
	Used bearing	8.34 — 16.67 N (0.85 — 1.70 kg, 1.87 — 3.75 lb)
Preload adjusting spacer	Part No.	Length
	383695201	56.2 mm (2.213 in)
	383695202	56.4 mm (2.220 in)
	383695203	56.6 mm (2.228 in)
	383695204	56.8 mm (2.236 in)
	383695205	57.0 mm (2.244 in)
Preload adjusting washer	Part No.	Thickness
	383705200	2.59 mm (0.1020 in)
	383715200	2.57 mm (0.1012 in)
	383725200	2.55 mm (0.1004 in)
	383735200	2.53 mm (0.0996 in)
	383745200	2.51 mm (0.0988 in)
	383755200	2.49 mm (0.0980 in)
	383765200	2.47 mm (0.0972 in)
	383775200	2.45 mm (0.0965 in)
	383785200	2.43 mm (0.0957 in)
	383795200	2.41 mm (0.0949 in)
	383805200	2.39 mm (0.0941 in)
	383815200	2.37 mm (0.0933 in)
	383825200	2.35 mm (0.0925 in)
383835200	2.33 mm (0.0917 in)	
383845200	2.31 mm (0.0909 in)	

SPECIFICATIONS AND SERVICE DATA

[S2C2] **3-4**
2. Rear Differential

Pinion height adjusting shim	Part No.	Thickness
	383495200	3.09 mm (0.1217 in)
	383505200	3.12 mm (0.1228 in)
	383515200	3.15 mm (0.1240 in)
	383525200	3.18 mm (0.1252 in)
	383535200	3.21 mm (0.1264 in)
	383545200	3.24 mm (0.1276 in)
	383555200	3.27 mm (0.1287 in)
	383565200	3.30 mm (0.1299 in)
	383575200	3.33 mm (0.1311 in)
	383585200	3.36 mm (0.1323 in)
	383595200	3.39 mm (0.1335 in)
	383605200	3.42 mm (0.1346 in)
	383615200	3.45 mm (0.1358 in)
	383625200	3.48 mm (0.1370 in)
	383635200	3.51 mm (0.1382 in)
	383645200	3.54 mm (0.1394 in)
	383655200	3.57 mm (0.1406 in)
	383665200	3.60 mm (0.1417 in)
	383675200	3.63 mm (0.1429 in)
383685200	3.66 mm (0.1441 in)	
Side gear backlash	—	0.10 — 0.20 mm (0.0039 — 0.0079 in)
Side gear thrust washer	Part No.	Thickness
	383445201	0.75 — 0.80 mm (0.0295 — 0.0315 in)
	383445202	0.80 — 0.85 mm (0.0315 — 0.0335 in)
	383445203	0.85 — 0.90 mm (0.0335 — 0.0354 in)
Side bearing standard width	—	20.00 mm (0.7874 in)
Side bearing retainer shim	Part No.	Thickness
	383475201	0.20 mm (0.0079 in)
	383475202	0.25 mm (0.0098 in)
	383475203	0.30 mm (0.0118 in)
	383475204	0.40 mm (0.0157 in)
	383475205	0.50 mm (0.0197 in)
Crown gear to drive pinion backlash		0.10 — 0.20 mm (0.0039 — 0.0079 in)
Crown gear runout on its back surface	Limit	0.05 mm (0.0020 in)
Oil capacity		0.8 ℓ (0.8 US qt, 0.7 Imp qt)

2. REAR DIFFERENTIAL (VA-TYPE)

Front and rear bearing preload at companion flange bolt hole	New bearing	12.7 — 32.4 N (1.3 — 3.3 kg, 2.9 — 7.3 lb)
Preload adjusting spacer	Part No.	Length mm (in)
	32288AA040	52.3 (2.059)
	32288AA050	52.5 (2.067)
	31454AA100	52.6 (2.071)
	32288AA060	52.7 (2.075)
	31454AA110	52.8 (2.079)
	32288AA070	52.9 (2.083)
	31454AA120	53.0 (2.087)
	32288AA080	53.1 (2.091)
	32288AA090	53.3 (2.098)

SPECIFICATIONS AND SERVICE DATA

	Part No.	Thickness mm (in)
Preload adjusting washer	38336AA000	1.500 (0.0591)
	38336AA120	1.513 (0.0596)
	38336AA010	1.525 (0.0600)
	38336AA130	1.538 (0.0606)
	38336AA020	1.550 (0.0610)
	38336AA140	1.563 (0.0615)
	38336AA030	1.575 (0.0620)
	38336AA150	1.588 (0.0625)
	38336AA040	1.600 (0.0630)
	38336AA160	1.613 (0.0635)
	38336AA050	1.625 (0.0640)
	38336AA170	1.638 (0.0645)
	38336AA060	1.650 (0.0650)
	38336AA180	1.663 (0.0655)
	38336AA070	1.675 (0.0659)
	38336AA190	1.688 (0.0665)
	38336AA080	1.700 (0.0669)
	38336AA200	1.713 (0.0674)
	38336AA090	1.725 (0.0679)
	38336AA210	1.738 (0.0684)
38336AA100	1.750 (0.0689)	
38336AA220	1.763 (0.0694)	
38336AA110	1.775 (0.0699)	
Pinion height adjusting shim	Part No.	Thickness mm (in)
	32295AA200	0.150 (0.0059)
	32295AA210	0.175 (0.0069)
	32295AA220	0.200 (0.0079)
	32295AA230	0.225 (0.0089)
	32295AA240	0.250 (0.0098)
	32295AA250	0.275 (0.0108)
Side gear backlash	0.05 — 0.15 mm (0.0020 — 0.0059 in)	
Side gear thrust washer	Part No.	Thickness mm (in)
	803135011	0.925 — 0.950 (0.0364 — 0.0374)
	803135012	0.950 — 0.975 (0.0374 — 0.0384)
	803135013	0.975 — 1.000 (0.0384 — 0.0394)
	803135014	1.000 — 1.025 (0.0394 — 0.0404)
	803135015	1.025 — 1.050 (0.0404 — 0.0413)
Crown gear to drive pinion backlash	0.10 — 0.15 (0.0039 — 0.0059)	
Crown gear runout on its back surface	Limit	0.05 (0.0020)
Oil capacity	0.8 ℓ (0.8 US qt, 0.7 Imp qt)	

D: REAR DIFFERENTIAL GEAR OIL

- Recommended oil

CAUTION:

Each oil manufacturer has its base oil and additives. Thus, do not mix two or more brands.

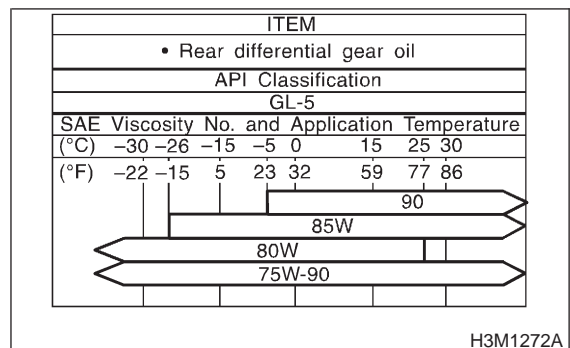

SPECIFICATIONS AND SERVICE DATA

[S2D0] **3-4**
2. Rear Differential

MEMO:

1. Propeller Shaft

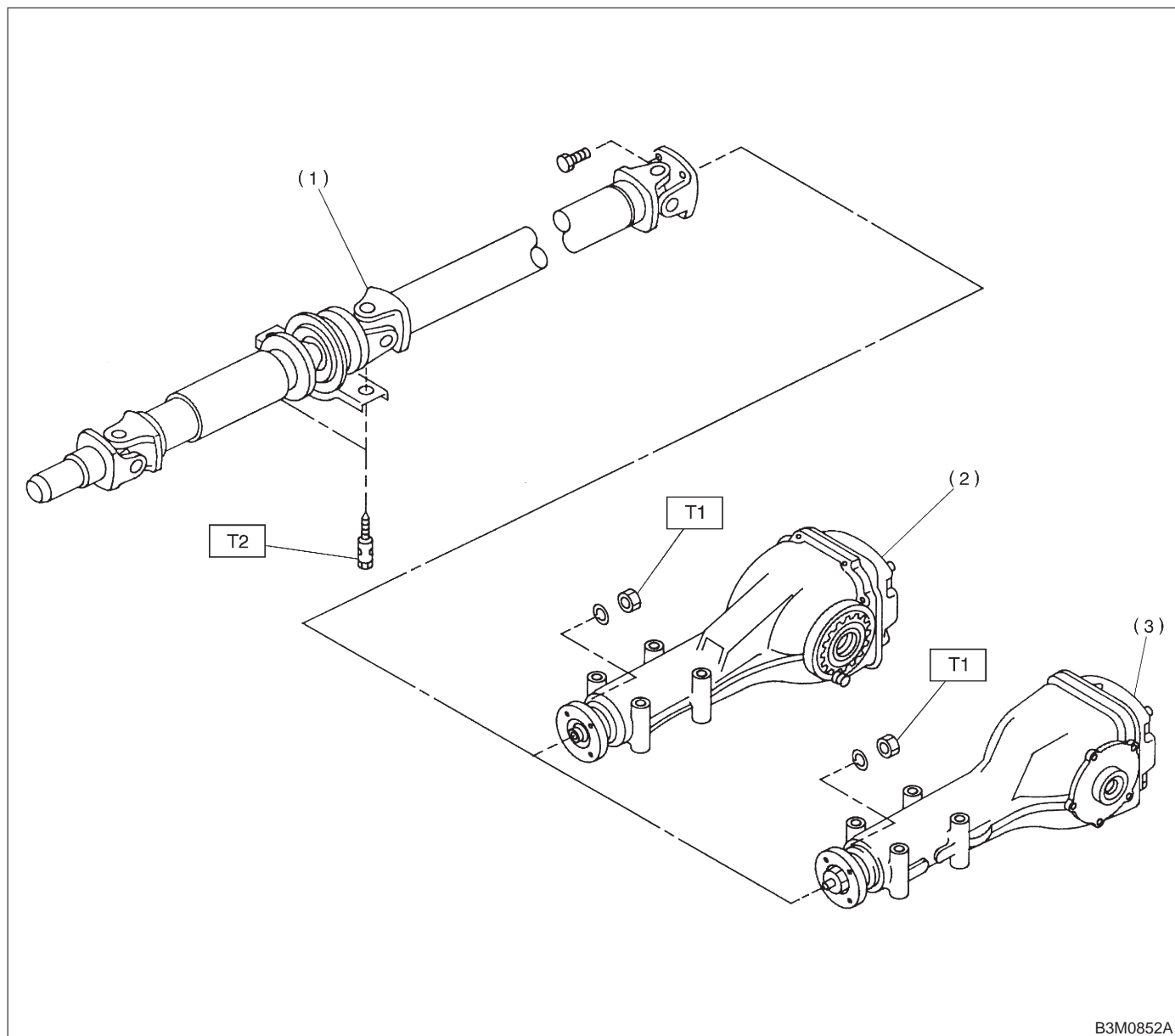

B3M0852A

- (1) Propeller shaft
- (2) Rear differential (VA-type)
- (3) Rear differential (T-type)

Tightening torque: N-m (kg-m, ft-lb)

T1: 31±8 (3.2±0.8, 23.1±5.8)

T2: 52±5 (5.3±0.5, 38.3±3.6)

2. Rear Differential Assembly

A: T-TYPE

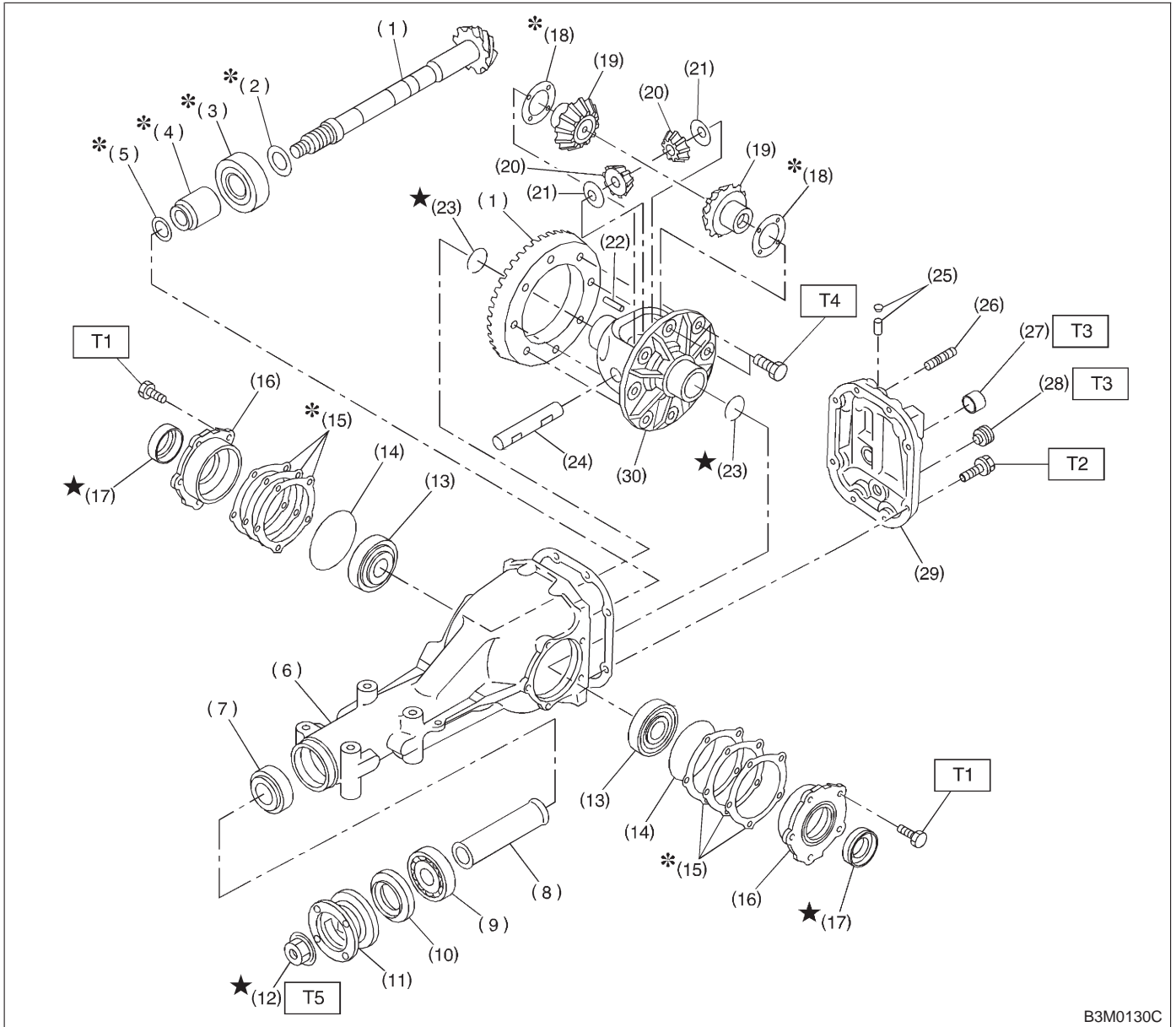

B3M0130C

- | | | |
|--------------------------------------|---------------------------------|------------------------|
| (1) Pinion crown gear set | (14) O-ring | (28) Oil drain plug |
| (2) Pinion height adjusting washer | (15) Side bearing retainer shim | (29) Rear cover |
| (3) Rear bearing | (16) Side bearing retainer | (30) Differential case |
| (4) Bearing preload adjusting spacer | (17) Side oil seal | |
| (5) Bearing preload adjusting washer | (18) Side gear thrust washer | |
| (6) Differential carrier | (19) Side gear | |
| (7) Front bearing | (20) Pinion mate gear | |
| (8) Spacer | (21) Pinion mate gear washer | |
| (9) Pilot bearing | (22) Pinion shaft lock pin | |
| (10) Front oil seal | (23) Circlip | |
| (11) Companion flange | (24) Pinion mate shaft | |
| (12) Self-locking nut | (25) Air breather cap | |
| (13) Side bearing | (26) Stud bolt | |
| | (27) Oil filler plug | |

Tightening torque: N-m (kg-m, ft-lb)
T1: 10.3±1.5 (1.05±0.15, 7.6±1.1)
T2: 29.4±4.9 (3.00±0.50, 21.7±3.6)
T3: 44.1±3.9 (4.50±0.40, 32.5±2.9)
T4: 103.0±9.8 (10.50±1.00, 75.9±7.2)
T5: 181.4±14.7 (18.50±1.50, 133.8±10.8)

COMPONENT PARTS

B: VA-TYPE

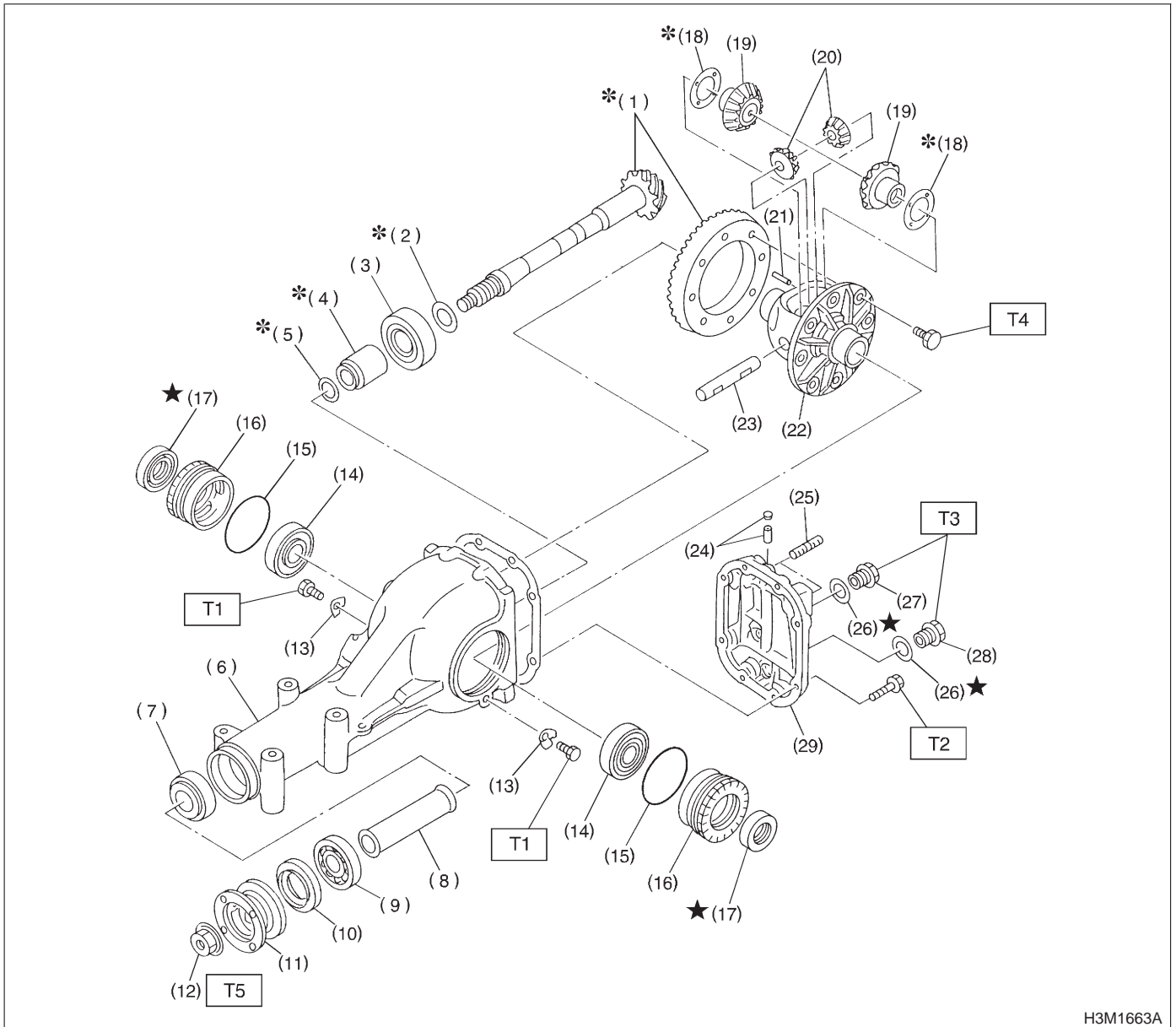

H3M1663A

- (1) Pinion crown gear set
- (2) Pinion height adjusting shim
- (3) Rear bearing
- (4) Bearing preload adjusting spacer
- (5) Bearing preload adjusting washer
- (6) Differential carrier
- (7) Front bearing
- (8) Collar
- (9) Pilot bearing
- (10) Front oil seal
- (11) Companion flange
- (12) Self-locking nut

- (13) Lock plate
- (14) Side bearing
- (15) O-ring
- (16) Axle shaft holder
- (17) Side oil seal
- (18) Side gear thrust washer
- (19) Side gear
- (20) Pinion mate gear
- (21) Pinion shaft lock pin
- (22) Differential case
- (23) Pinion mate shaft
- (24) Air breather cap
- (25) Stud bolt

- (26) Gasket
- (27) Oil filler plug
- (28) Oil drain plug
- (29) Rear cover

Tightening torque: N-m (kg-m, ft-lb)

T1: 25±3 (2.5±0.3, 18.1±2.2)

T2: 25±2 (2.5±0.2, 18.1±1.4)

T3: 34±4 (3.5±0.4, 25.3±2.9)

T4: 62±5 (6.3±0.5, 45.6±3.6)

T5: 188±26 (19.2±2.7, 139±20)

3. Rear Differential Mounting System

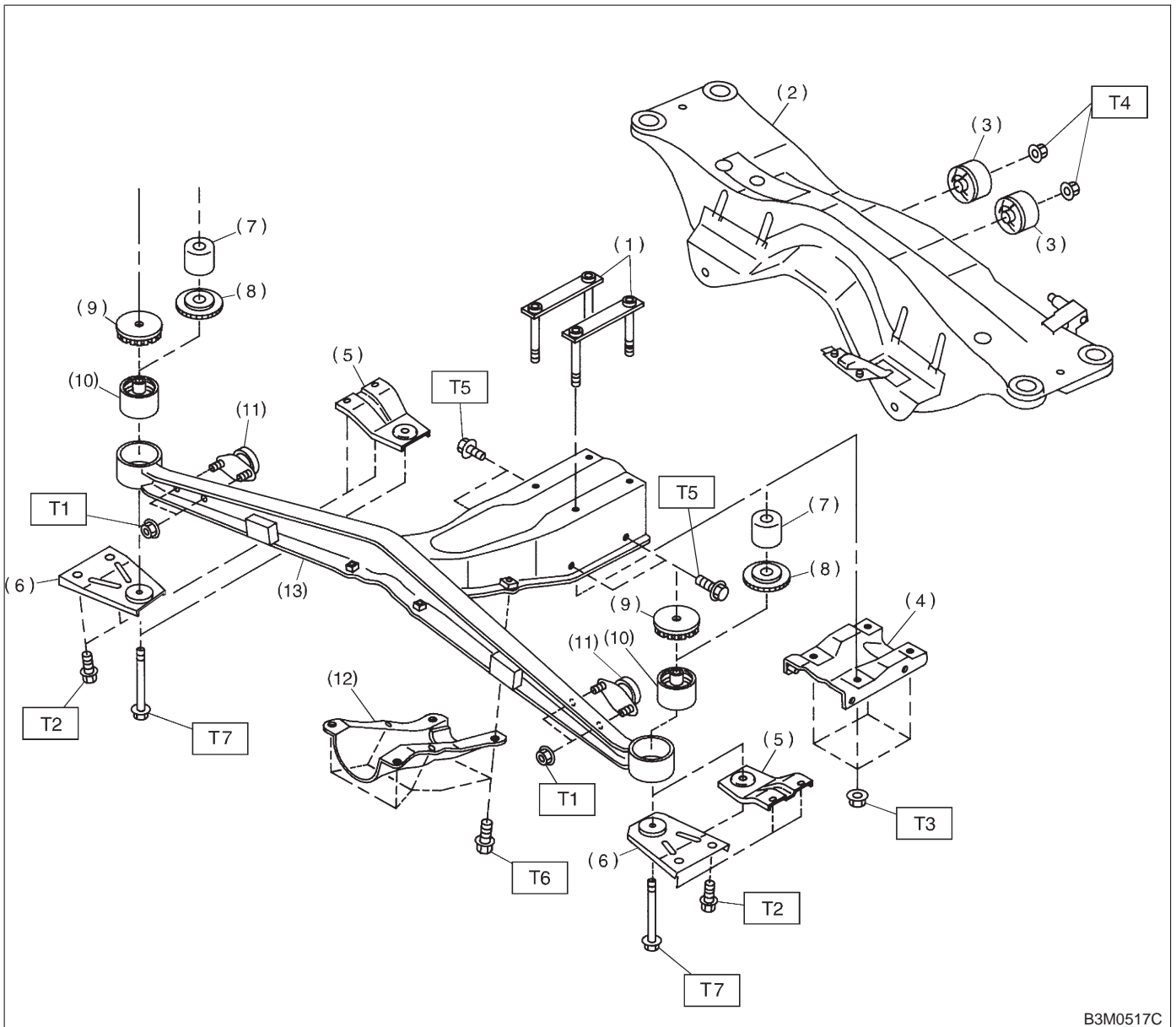

B3M0517C

- | | |
|--|--|
| (1) Plate | (9) Stopper |
| (2) Crossmember | (10) Front bushing |
| (3) Rear bushing | (11) Dynamic damper (2500 cc MT model) |
| (4) Differential mount lower bracket | (12) Differential mount front cover |
| (5) Differential mount bracket (OUTBACK model) | (13) Differential front member |
| (6) Differential mount bracket | |
| (7) Boss (OUTBACK model) | |
| (8) Stopper (OUTBACK model) | |

Tightening torque: N-m (kg-m, ft-lb)

- T1: 20±5 (2.0±0.5, 14.5±3.6)**
T2: 32±8 (3.3±0.8, 23.9±5.8)
T3: 64±8 (6.5±0.8, 47.0±5.8)
T4: 69±8 (7.0±0.8, 50.6±5.8)
T5: 69±10 (7.0±1.0, 51.0±7.2)
T6: 88±10 (9.0±1.0, 65.0±7.2)
T7: 98±10 (10.0±1.0, 72.0±7.2)

1. Propeller Shaft

A: ON-CAR SERVICE

1) Joints and connections

Check for any looseness of yoke flange connecting bolts and center bearing retaining bolts.

2) Splines and bearing locations

Turn propeller shaft by hand to see if abnormal free play exists at splines. Also move yokes to see if abnormal free play exists at spiders and bearings.

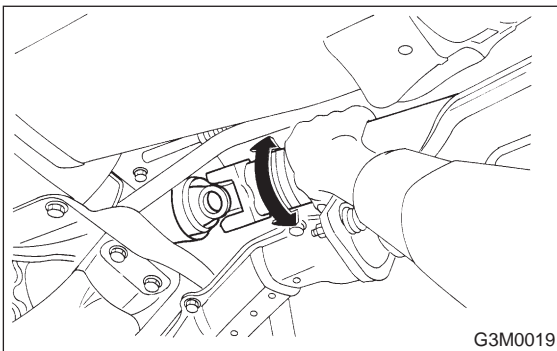

3) Runout of propeller shaft

Turn rear wheels by hand to check for "runout" of propeller shaft.

NOTE:

Measure runout with a dial gauge at the center of front and rear propeller shaft tubes.

Runout:

Limit 0.6 mm (0.024 in)

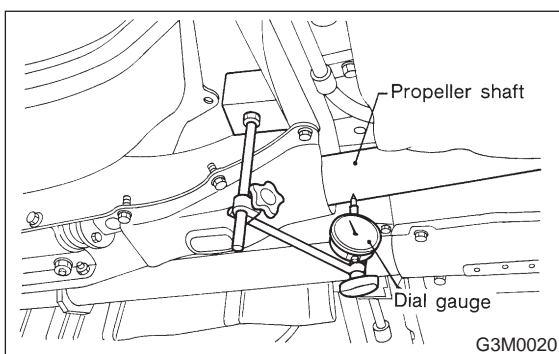

4) Center bearing free play

While holding propeller shaft near center bearing with your hand, move it up and down, and left and right to check for any abnormal bearing free play.

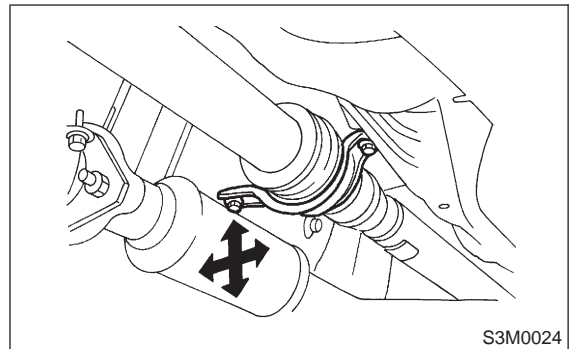

B: REMOVAL

NOTE:

Before removing propeller shaft, wrap metal parts with a cloth or rubber material.

- 1) Disconnect ground cable from battery.
- 2) Move selector lever or gear shift lever to "N".
- 3) Release the parking brake.
- 4) Jack-up vehicle and support it with sturdy racks.
- 5) Remove rear exhaust pipe. <Ref. to 2-9 [W2A0].>
- 6) Remove muffler. <Ref. to 2-9 [W3A0].>
- 7) Remove front exhaust cover.

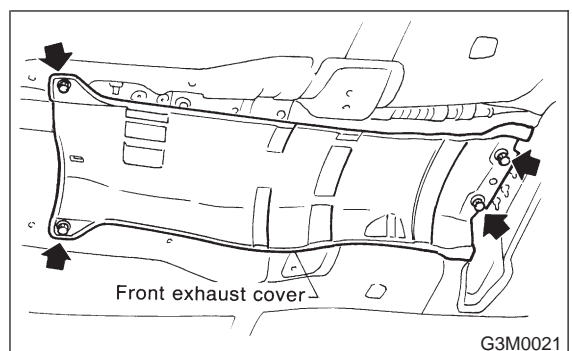

8) Remove differential mount front cover.

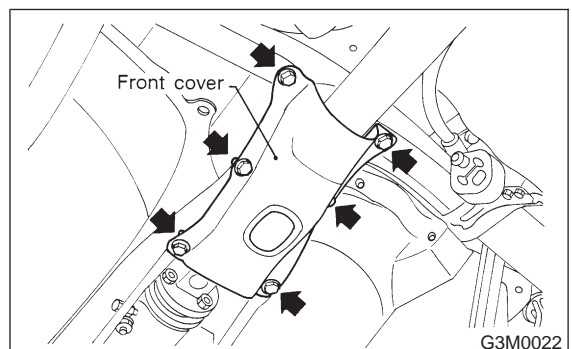

9) Remove the four bolts which hold propeller shaft to rear differential.

NOTE:

- Put matching mark on affected parts before removal.
- Remove all but one bolt.

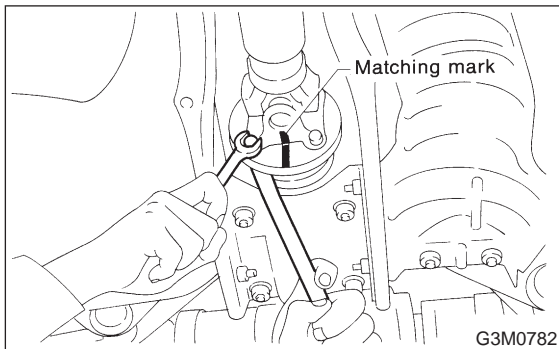

10) Remove the two bolts which hold center bearing to vehicle body.

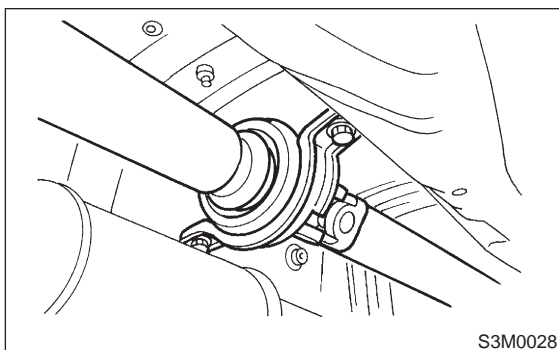

11) Remove propeller shaft from transmission.

CAUTION:

Be sure not to damage oil seals and the frictional surface of sleeve yoke.

NOTE:

- Be sure to use an empty oil can to catch oil flowing out when removing propeller shaft.
- Be sure to plug the opening in transmission after removal of propeller shaft.

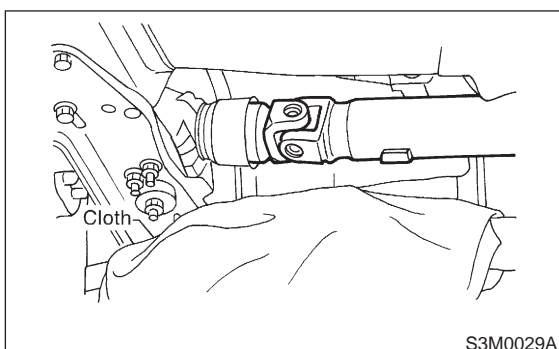

12) Install the extension cap to transmission.

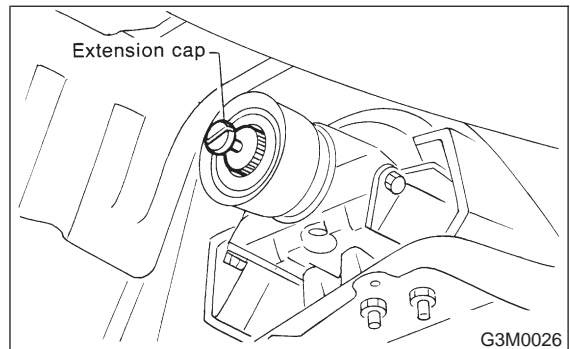

C: DISASSEMBLY AND ASSEMBLY

NOTE:

Do not disassemble propeller shaft. It is a single unit.

D: INSPECTION

NOTE:

Do not disassemble propeller shaft. Check the following and replace if necessary.

- 1) Tube surfaces for dents or cracks
- 2) Splines for deformation or abnormal wear
- 3) Joints for non-smooth operation or abnormal noise
- 4) Center bearing for free play, noise or non-smooth operation
- 5) Oil seals for abnormal wear or damage
- 6) Center bearing for breakage or damage to rubber boot

E: INSTALLATION

- 1) Insert sleeve yoke into transmission and attach center bearing to vehicle body.

Tightening torque:

$52 \pm 5 \text{ N}\cdot\text{m}$ ($5.3 \pm 0.5 \text{ kg}\cdot\text{m}$, $38.3 \pm 3.6 \text{ ft}\cdot\text{lb}$)

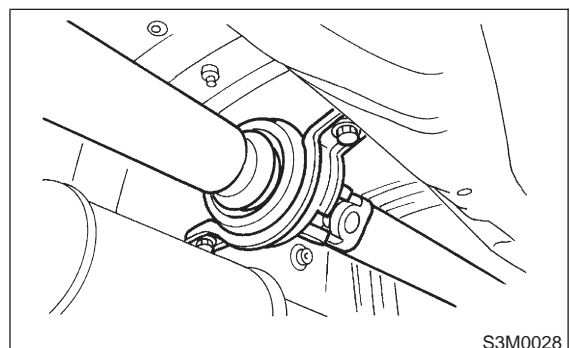

3-4 [W2A1]

2. Rear Differential

SERVICE PROCEDURE

- 2) Align matching marks and connect flange yoke and rear differential.

Tightening torque:

31 ± 8 N·m (3.2 ± 0.8 kg·m, 23.1 ± 5.8 ft·lb)

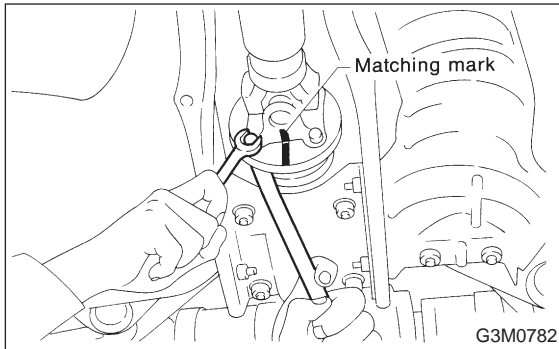

- 3) Install differential mount front cover.

Tightening torque:

88 ± 10 N·m (9.0 ± 1.0 kg·m, 65 ± 7 ft·lb)

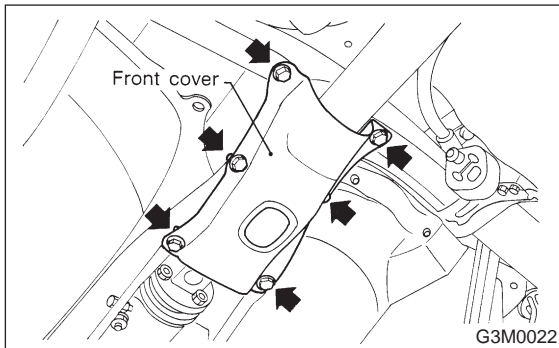

- 4) Install front exhaust cover.
- 5) Install rear exhaust pipe and muffler.

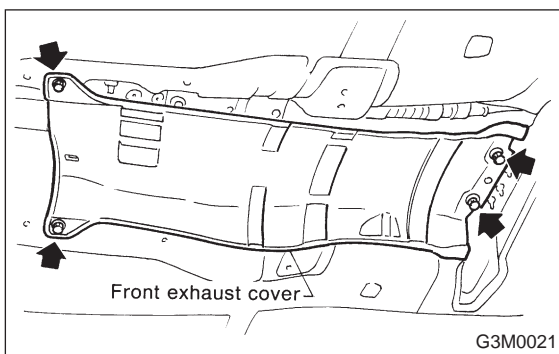

2. Rear Differential

A: ON-CAR SERVICE

1. FRONT OIL SEAL

- 1) Disconnect ground cable from battery.
- 2) Move selector lever or gear shift lever to "N".
- 3) Release the parking brake.
- 4) Remove oil drain plug, and drain gear oil.

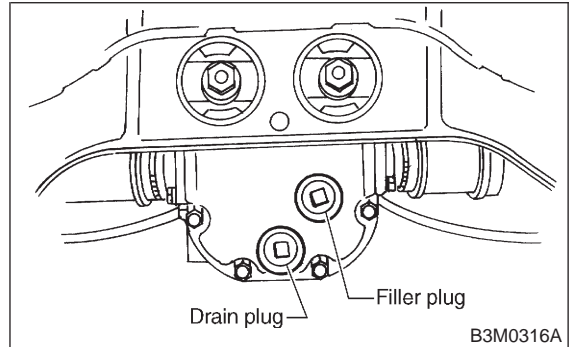

- 5) Jack-up rear wheels and support the vehicle body with sturdy racks.
- 6) Remove propeller shaft from body. <Ref. to 3-4 [W1B0].>

CAUTION:

Wrap metal parts with a cloth or rubber material to prevent damage from adjacent metal parts.

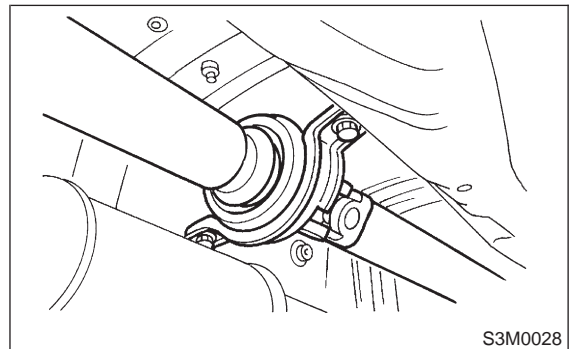

- 7) Remove self-locking nut while holding companion flange with ST.

ST 498427200 FLANGE WRENCH

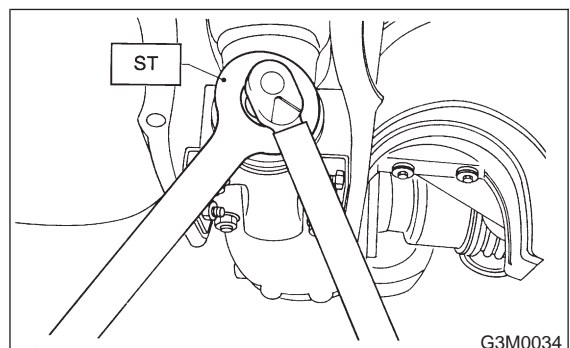

3-4 [W2A1]

2. Rear Differential

SERVICE PROCEDURE

2) Align matching marks and connect flange yoke and rear differential.

Tightening torque:

31 ± 8 N·m (3.2 ± 0.8 kg·m, 23.1 ± 5.8 ft·lb)

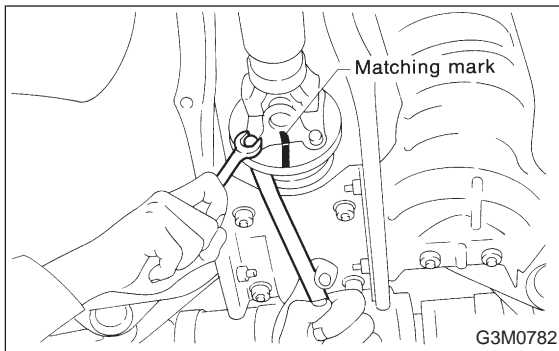

3) Install differential mount front cover.

Tightening torque:

88 ± 10 N·m (9.0 ± 1.0 kg·m, 65 ± 7 ft·lb)

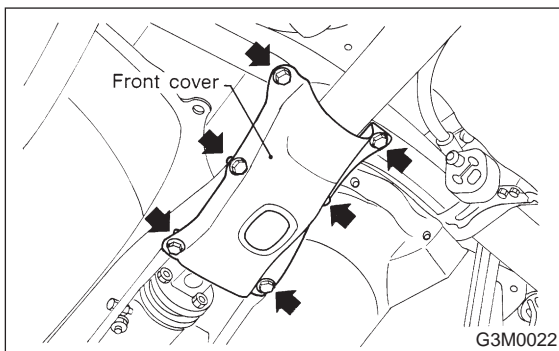

4) Install front exhaust cover.

5) Install rear exhaust pipe and muffler.

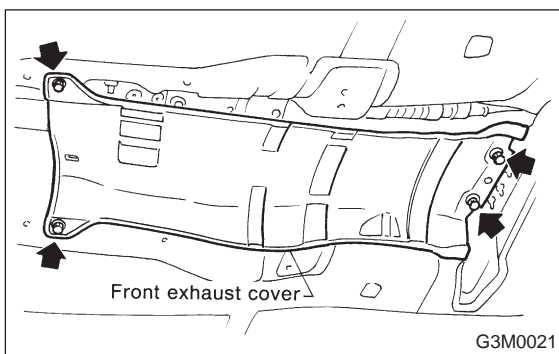

2. Rear Differential

A: ON-CAR SERVICE

1. FRONT OIL SEAL

- 1) Disconnect ground cable from battery.
- 2) Move selector lever or gear shift lever to "N".
- 3) Release the parking brake.
- 4) Remove oil drain plug, and drain gear oil.

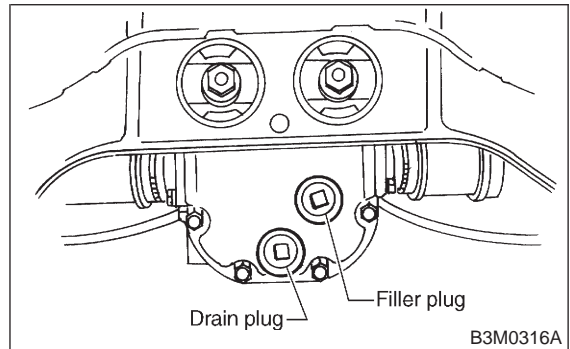

5) Jack-up rear wheels and support the vehicle body with sturdy racks.

6) Remove propeller shaft from body. <Ref. to 3-4 [W1B0].>

CAUTION:

Wrap metal parts with a cloth or rubber material to prevent damage from adjacent metal parts.

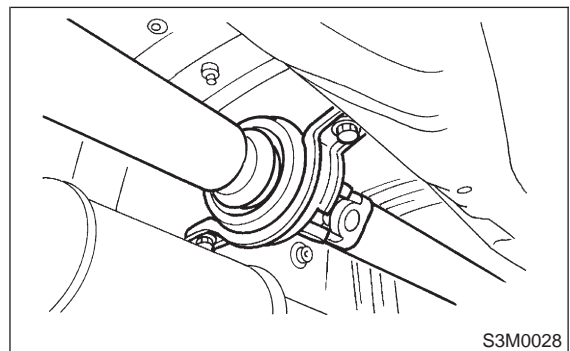

7) Remove self-locking nut while holding companion flange with ST.

ST 498427200 FLANGE WRENCH

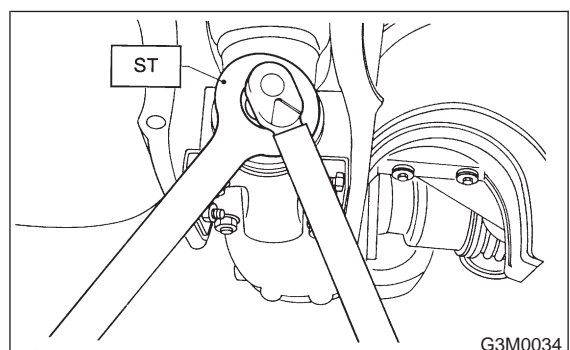

8) Extract companion flange with a puller.

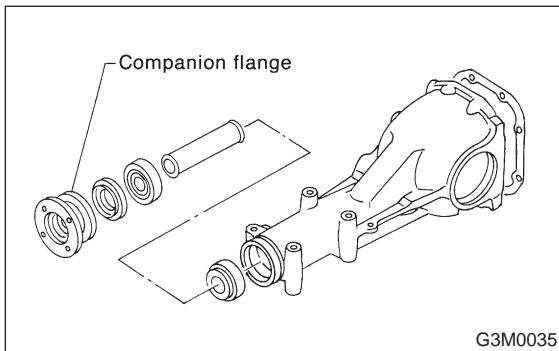

9) Remove oil seal using ST.
ST 398527700 PULLER ASSY (T-type)
ST 499705401 PULLER ASSY (VA-type)

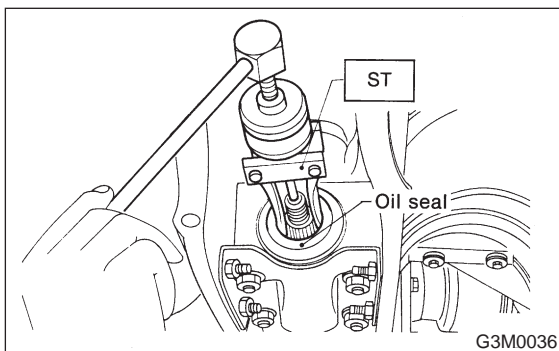

10) Fit a new oil seal using ST.
ST 498447120 OIL SEAL INSTALLER

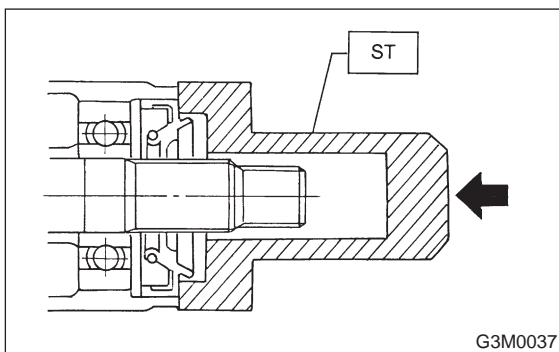

11) Install companion flange.

12) Tighten self-locking nut within the specified torque range so that the turning resistance of companion flange becomes the same as that before replacing oil seal.

CAUTION:
Use a new self-locking nut.

ST 498427200 FLANGE WRENCH

Tightening torque:

T-type;

181.4±14.7 N·m (18.50±1.50 kg·m,

133.8±10.8 ft·lb)

VA-type;

188±26 N·m (19.2±2.7 kg·m, 139±20 ft·lb)

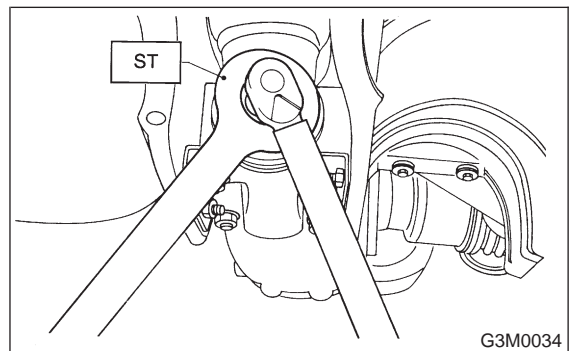

13) Reassembling procedure hereafter is the reverse of the disassembling.

2. SIDE OIL SEAL (T-TYPE)

- 1) Disconnect ground cable from battery.
- 2) Move selector lever or gear shift lever to "N".
- 3) Release the parking brake.
- 4) Loosen both wheel nuts.
- 5) Jack-up the vehicle and support it with rigid racks.
- 6) Remove wheels.
- 7) Remove rear exhaust pipe.
<Ref. to 2-9 [W2A0].>
- 8) Remove muffler.
<Ref. to 2-9 [W3A0].>
- 9) Remove the ABS sensor cable clamp and parking brake cable clamp from bracket.

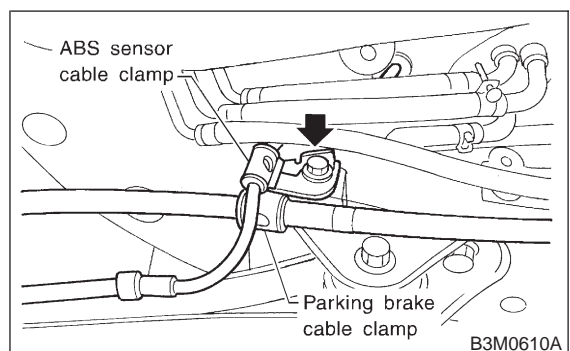

3-4 [W2A2]
2. Rear Differential

SERVICE PROCEDURE

10) Remove the ABS sensor cable clamp from the trailing link.

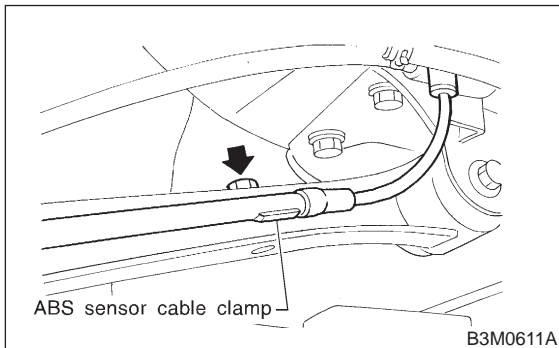

11) Remove the ABS sensor cable clamp and parking brake cable guide from the trailing link.

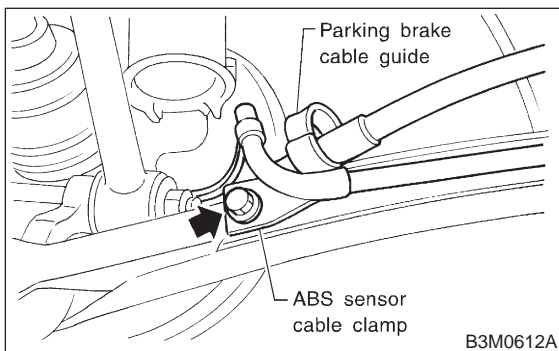

12) Remove the rear stabilizer link.

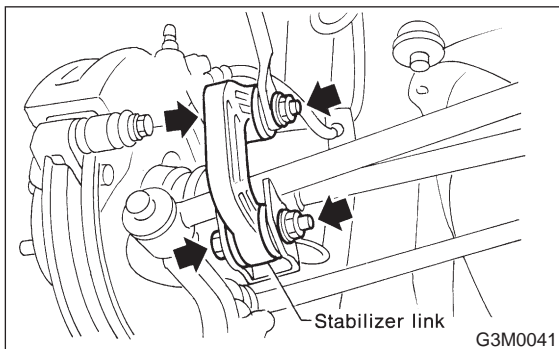

13) Remove the bolts which secure the trailing link to the rear housing.

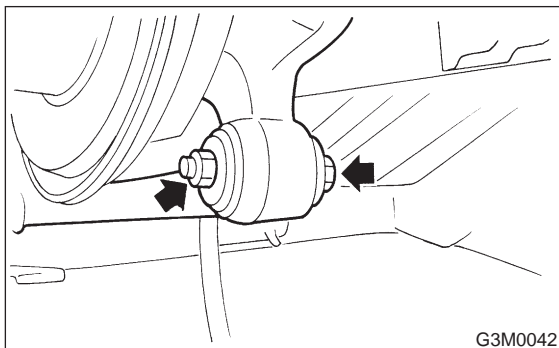

14) Remove the bolts which secure the front and rear lateral link to the rear housing.

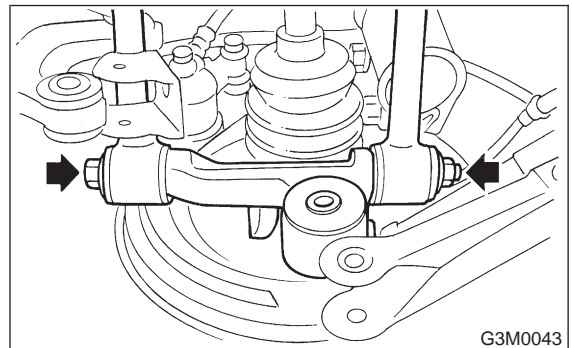

15) Remove crossmember reinforcement lower (Sedan only).

16) Remove the DOJ from the rear differential by using ST.

CAUTION:
When removing the DOJ from the rear differential, fit tire lever to the bolt as shown in figure so as not to damage the side bearing retainer.

ST 208099PA100 DRIVE SHAFT REMOVER

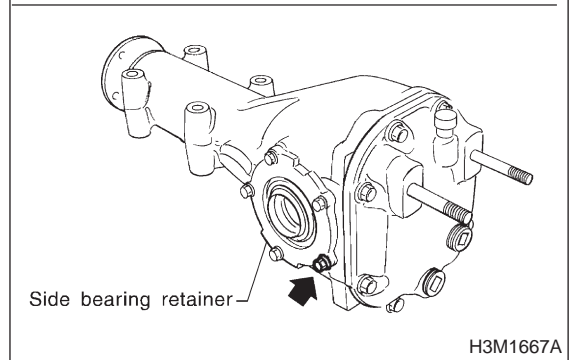
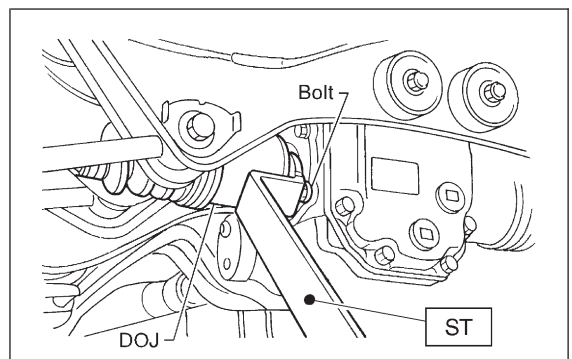

17) Secure rear drive shaft to rear crossmember using wire.

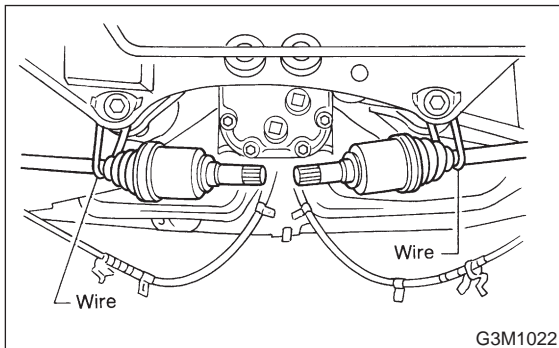

18) Remove side oil seal with ST.
ST 398527700 PULLER ASSY

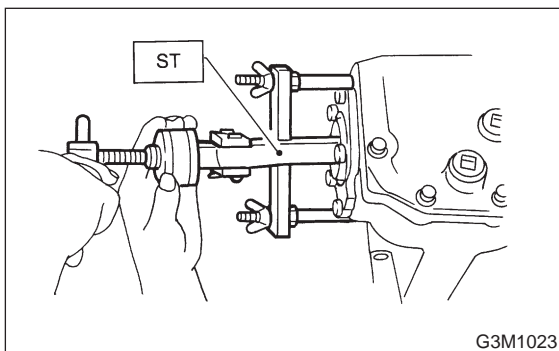

19) Drive in a new side oil seal with ST.

CAUTION:
Apply chassis grease between the oil seal lips.
ST 398437700 DRIFT

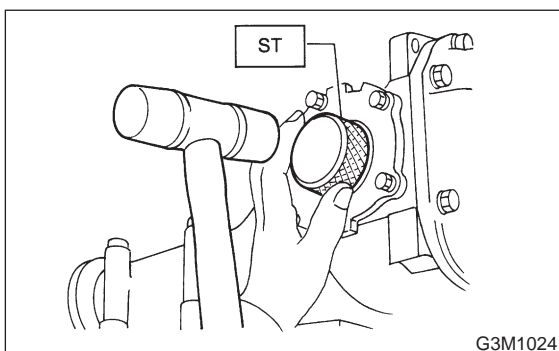

20) Install ST to rear differential.
ST 28099PA090 SIDE OIL SEAL PROTECTOR

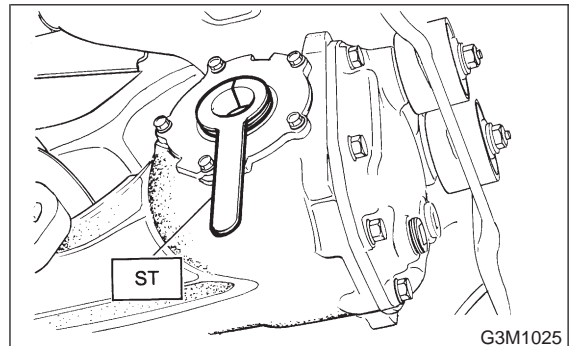

21) Insert the spline shaft until the spline portion is inside the side oil seal.

ST 28099PA090 SIDE OIL SEAL PROTECTOR

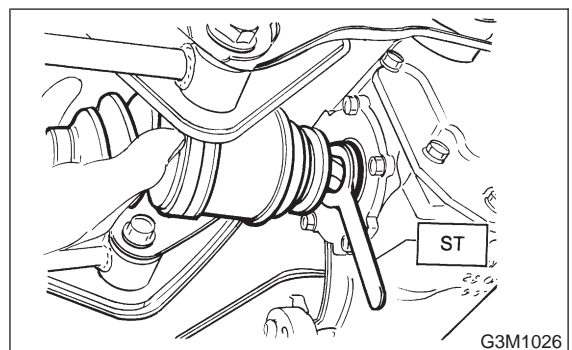

22) Remove ST.
ST 28099PA090 SIDE OIL SEAL PROTECTOR

23) Hereafter, re-assemble in reverse order of disassembly.

3. SIDE OIL SEAL (VA-TYPE)

- 1) Disconnect ground cable from battery.
- 2) Move selector lever or gear shift lever to "N".
- 3) Release the parking brake.
- 4) Loosen both wheel nuts.
- 5) Jack-up the vehicle and support it with rigid racks.
- 6) Remove wheels.
- 7) Remove rear exhaust pipe.
<Ref. to 2-9 [W2A0].>
- 8) Remove muffler.
<Ref. to 2-9 [W3A0].>
- 9) Remove the DOJ of rear drive shaft from rear differential.

(1) Remove the ABS sensor cable clamp and parking brake cable clamp from bracket.

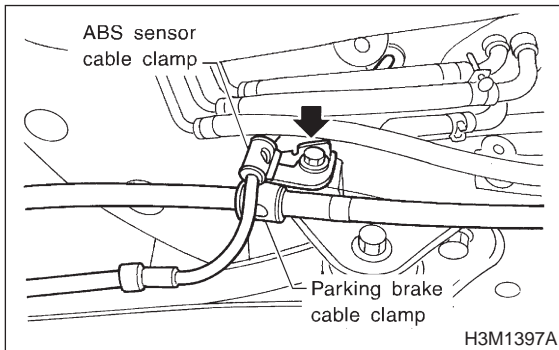

(2) Remove the ABS sensor cable clamp from the trailing link.

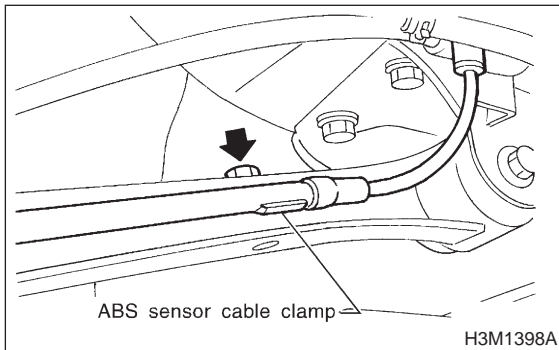

(3) Remove the ABS sensor cable clamp and parking brake cable guide from the trailing link.

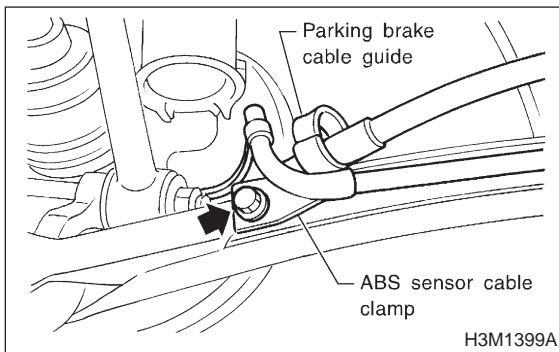

(4) Remove the rear stabilizer link.

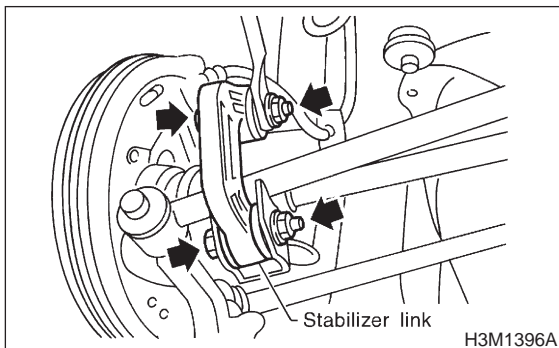

(5) Remove the bolts which secure the trailing link to the rear housing.

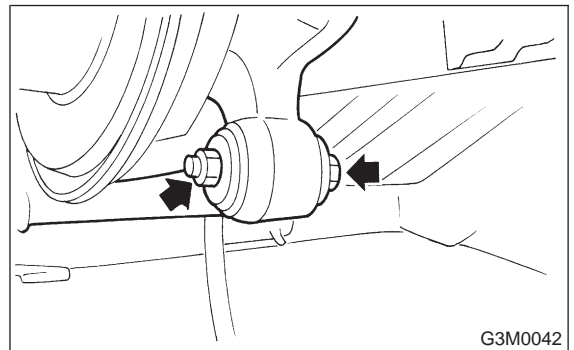

(6) Remove the bolts which secure the front and rear lateral link to the rear housing.

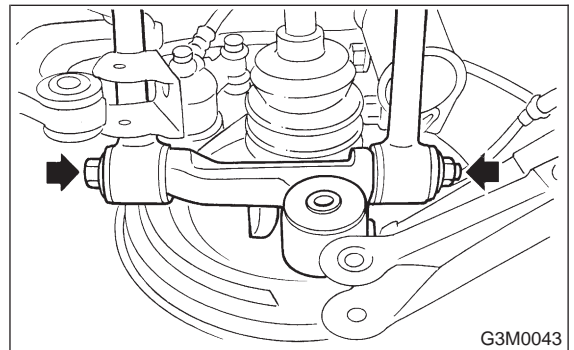

(7) Remove the DOJ from the rear differential with tire lever.

CAUTION:

When removing the DOJ from the rear differential, fit tire lever to the bolt as shown in figure so as not to damage the axle shaft holder.

NOTE:

The side spline shaft circlip comes out together with the shaft.

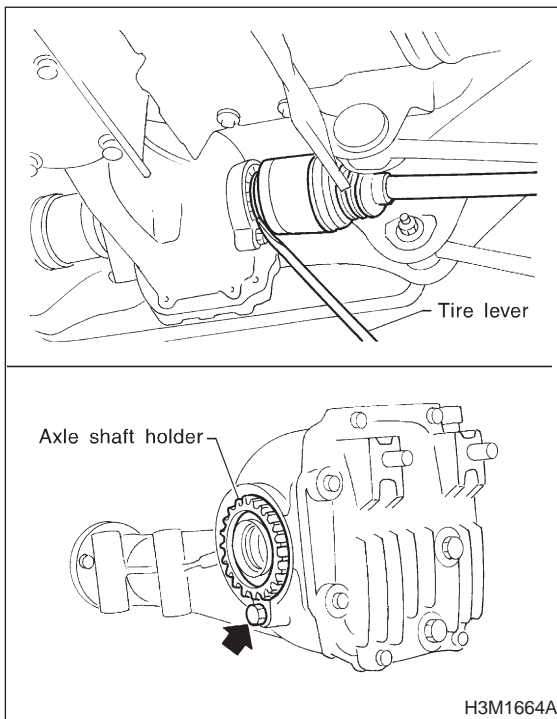

10) Secure rear drive shaft to rear crossmember using wire.

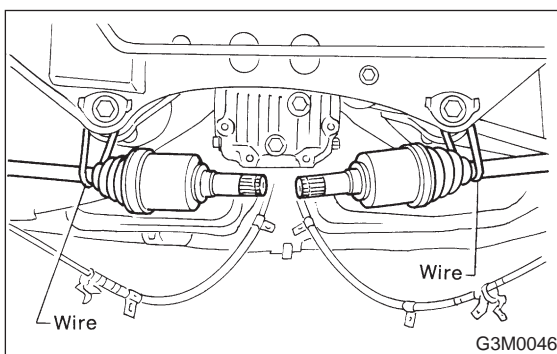

11) Remove oil seal with screwdriver.

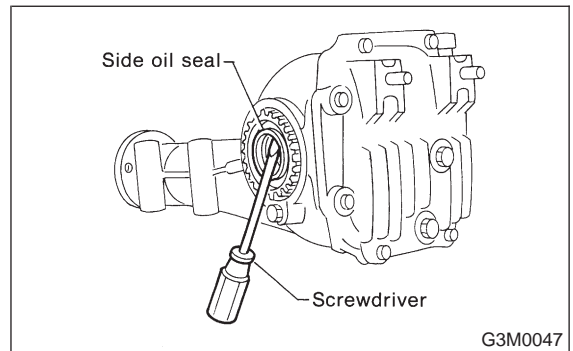

12) Drive in a new side oil seal with ST.

CAUTION:

Apply chassis grease between the oil seal lips.

ST 498447100 OIL SEAL INSTALLER

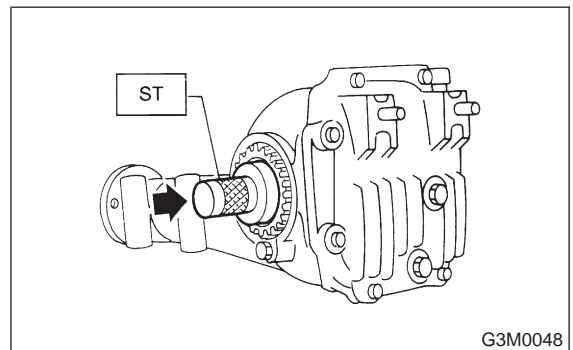

13) Install ST to rear differential.

ST 28099PA090 SIDE OIL SEAL PROTECTOR

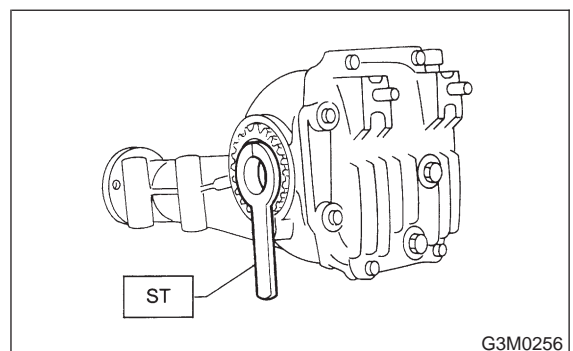

3-4 [W2B1]

2. Rear Differential

SERVICE PROCEDURE

14) Insert the spline shaft until the spline portion is inside the side oil seal.

CAUTION:

Before inserting, replace the circlip at the end of the spline shaft with a new one.

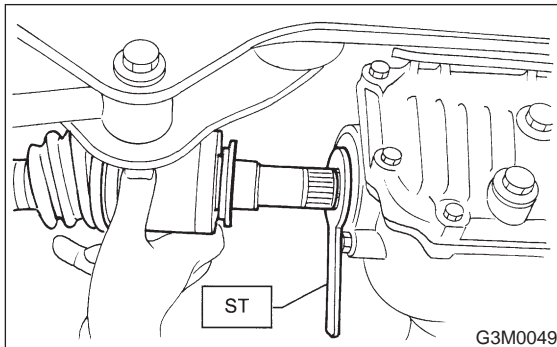

15) Remove ST.

ST 28099PA090 SIDE OIL SEAL PROTECTOR

16) Completely insert DOJ into rear differential by pressing rear housing.

NOTE:

Make sure that oil seal lip is not folded over inward.

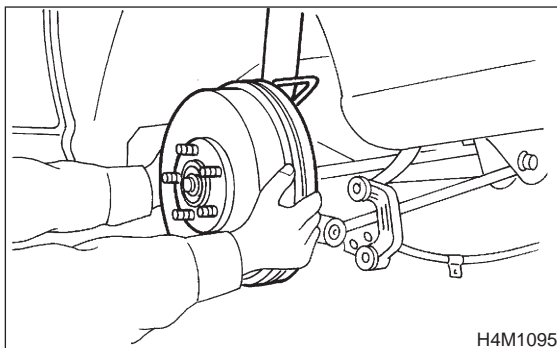

17) Hereafter, re-assemble in reverse order of disassembly.

B: REMOVAL

1. T-TYPE

- 1) Disconnect ground cable from battery.
- 2) Move selector lever or gear shift lever to "N".
- 3) Release the parking brake.
- 4) Loosen wheel nuts.
- 5) Jack-up vehicle and support it with sturdy racks.
- 6) Remove wheels.
- 7) Remove rear exhaust pipe.
<Ref. to 2-9 [W2A0].>
- 8) Remove muffler.
<Ref. to 2-9 [W3A0].>

9) Remove front exhaust cover.

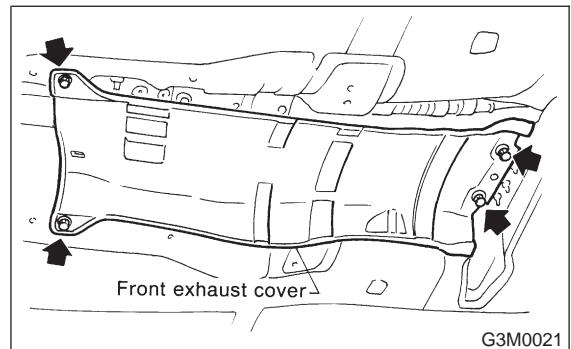

10) Remove front cover of rear differential mount.

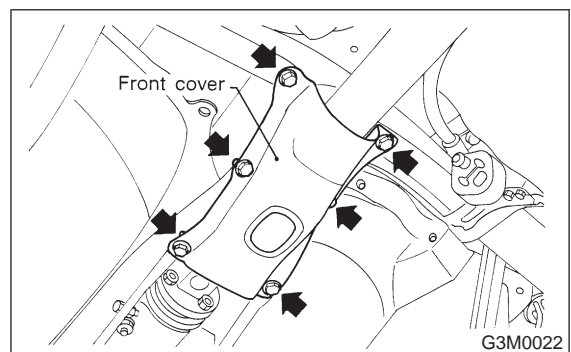

11) Remove propeller shaft.

CAUTION:

When removing propeller shaft, pay attention not to damage the sliding surfaces of rear drive shaft (extension) spline, oil seal and sleeve yoke.

NOTE:

- Prepare an oil can and cap since the transmission oil flows out from the extension at removing propeller shaft.
- Insert the cap into the extension to prevent transmission oil from flowing out immediately after removing the propeller shaft.

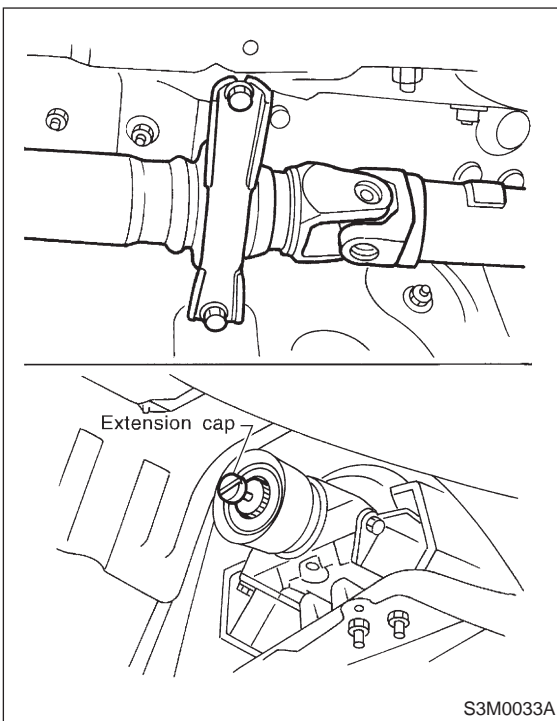

12) Remove heat sealed cover.

13) Remove clamps and bracket of parking brake cable.

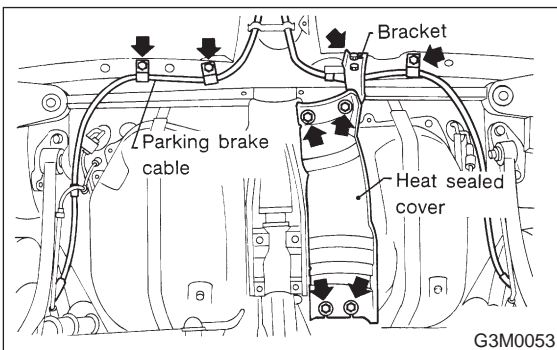

14) Remove crossmember reinforcement lower (Sedan only).

15) Remove DOJ of rear drive shaft from rear differential using ST. <Ref. to 3-4 [W2A2].>

ST 28099PA100 DRIVE SHAFT REMOVER

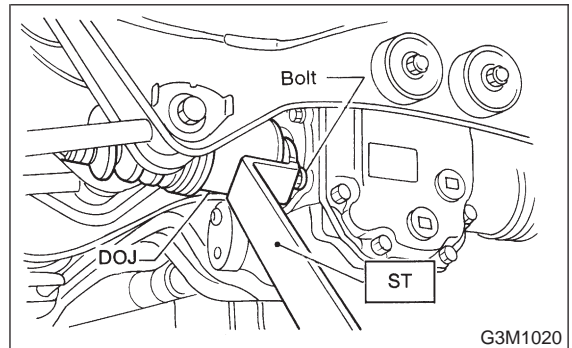

16) Secure rear drive shaft to rear crossmember using wire.

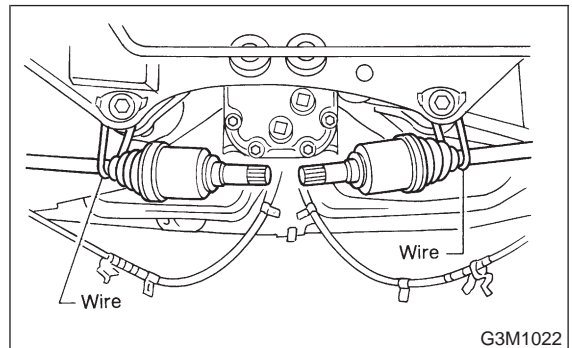

17) Remove lower differential bracket.

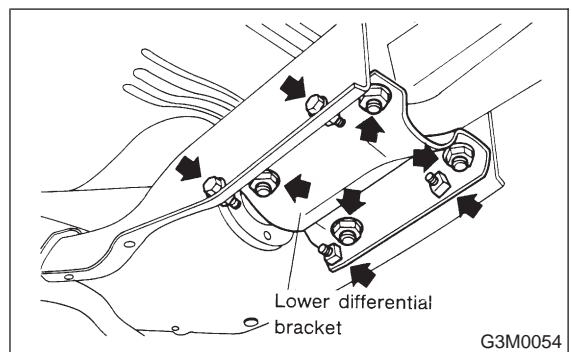

18) Support rear differential with transmission jack.

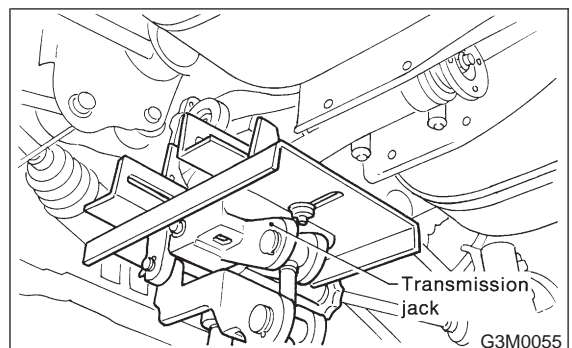

3-4 [W2B2]

2. Rear Differential

SERVICE PROCEDURE

19) Remove self-locking nuts connecting rear differential to rear crossmember.

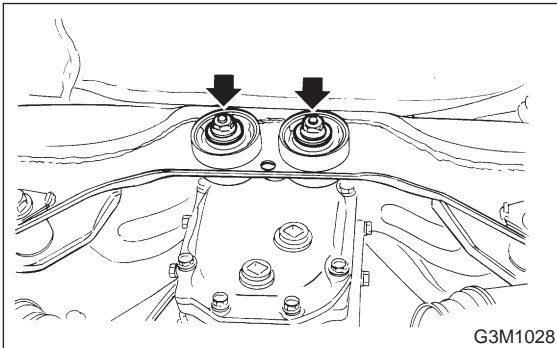

20) Remove bolts which secure rear differential front member to body. Loosen bolt (A) first, then remove bolts (B).

NOTE:

Support front member with the use of a helper to prevent it from dropping.

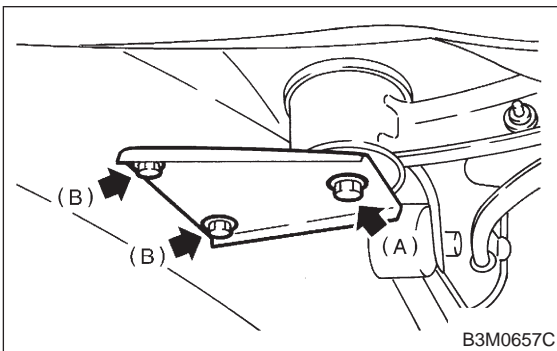

(A) Bolt A

(B) Bolt B

21) Remove bolt A.

22) While slowly lowering transmission jack, move rear differential forward and remove front member and rear differential from body.

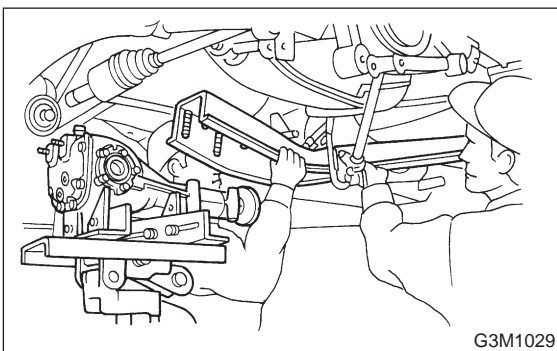

23) Remove rear differential from front member.

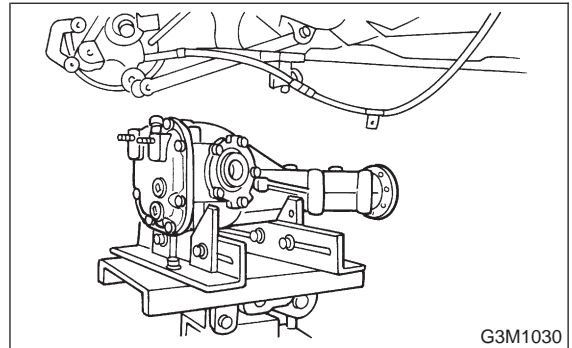

2. VA-TYPE

- 1) Disconnect ground cable from battery.
- 2) Move selector lever or gear shift lever to "N".
- 3) Release the parking brake.
- 4) Loosen wheel nuts.
- 5) Jack-up vehicle and support it with sturdy racks.
- 6) Remove wheels.
- 7) Remove rear exhaust pipe.
<Ref. to 2-9 [W2A0].>
- 8) Remove muffler.
<Ref. to 2-9 [W3A0].>
- 9) Remove front exhaust cover.

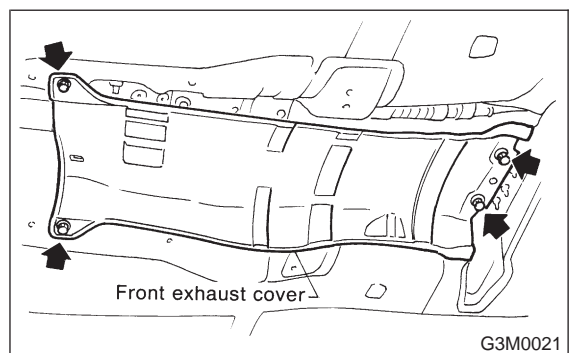

10) Remove front cover of rear differential mount.

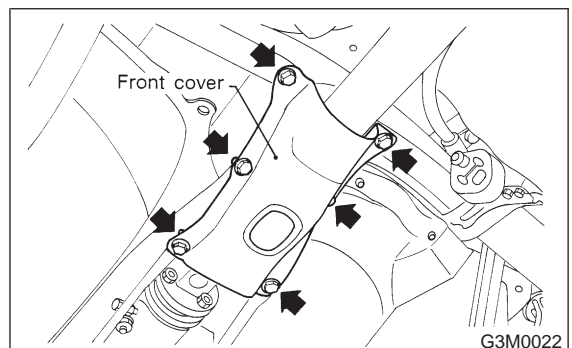

11) Remove propeller shaft.

CAUTION:

When removing propeller shaft, pay attention not to damage the sliding surfaces of rear drive shaft (extension) spline, oil seal and sleeve yoke.

NOTE:

- Prepare an oil can and cap since the transmission oil flows out from the extension at removing propeller shaft.
- Insert the cap into the extension to prevent transmission oil from flowing out immediately after removing the propeller shaft.

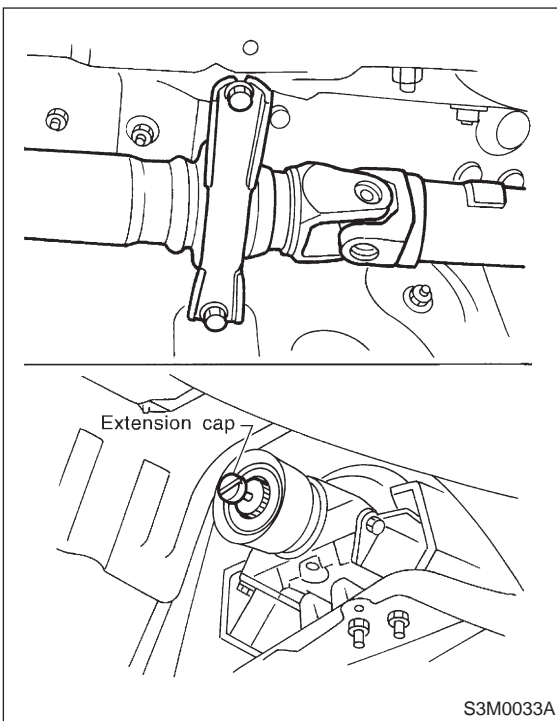

12) Remove heat sealed cover.

13) Remove clamps and bracket of parking brake cable.

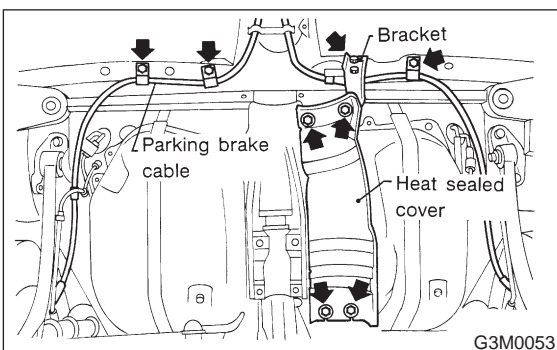

14) Remove DOJ of rear drive shaft from rear differential. <Ref. to 3-4 [W2A3].>

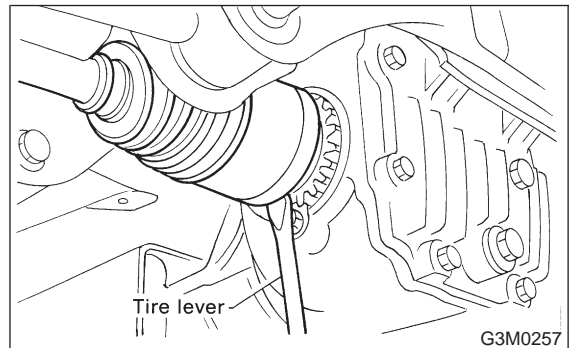

15) Secure rear drive shaft to rear crossmember using wire.

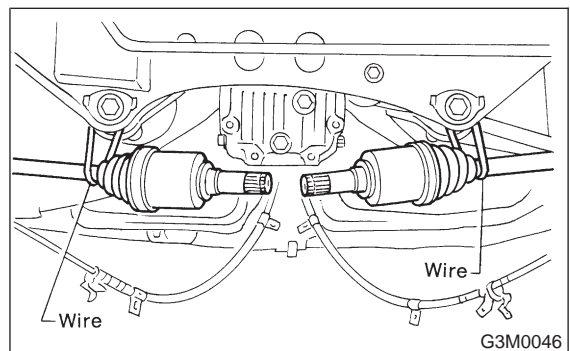

16) Remove lower differential bracket.

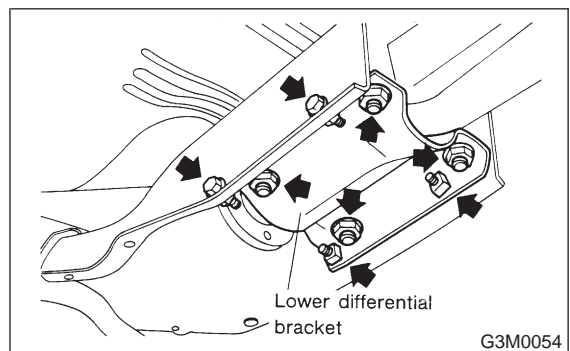

17) Support rear differential with transmission jack.

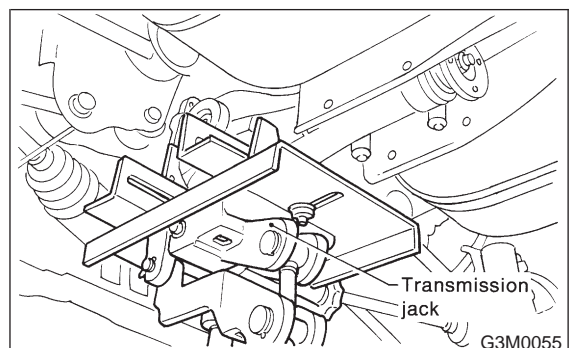

3-4 [W2C1]

2. Rear Differential

SERVICE PROCEDURE

18) Remove self-locking nuts connecting rear differential to rear crossmember.

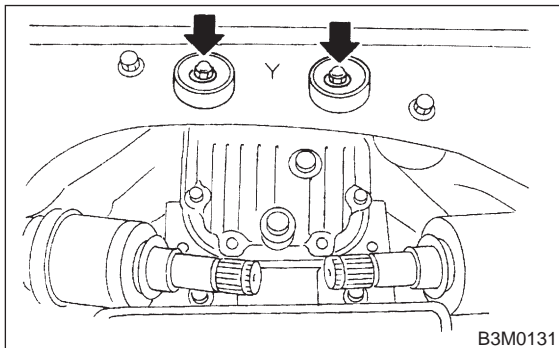

19) Remove bolts which secure rear differential front member to body. Loosen bolt A first, then removal bolts B.

NOTE:

Support front member with the use of a helper to prevent it from dropping.

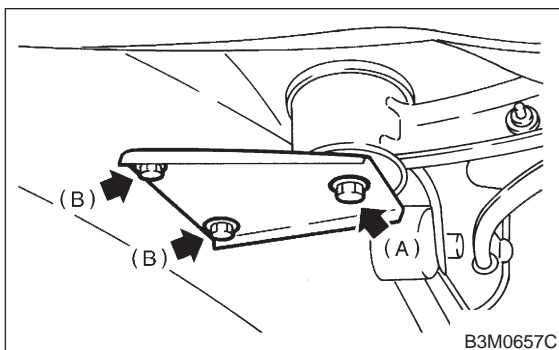

- (A) Bolt A
- (B) Bolt B

20) Remove bolt A.

21) While slowly lowering transmission jack, move rear differential forward and remove bolts from rear crossmember.

22) Remove front member from body.

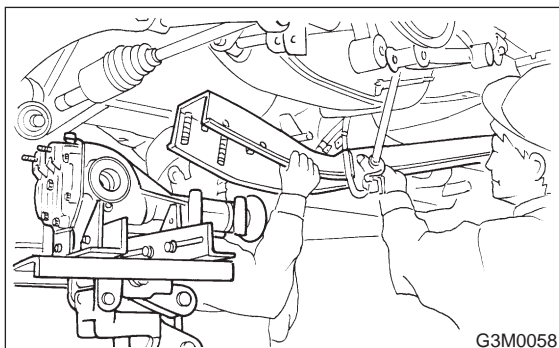

23) Remove rear differential from body.

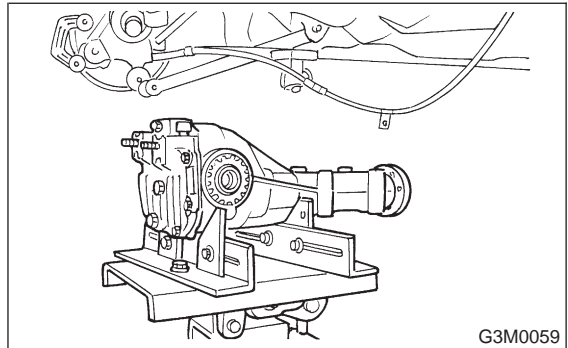

C: DISASSEMBLY

1. T-TYPE

NOTE:

To detect real cause of trouble, inspect the following items before disassembling.

- Tooth contact of crown gear and pinion, and backlash
- Runout of crown gear at its back surface
- Turning resistance of drive pinion

1) Set ST on vise and install the differential assembly to ST.

ST 39821770 ATTACHMENT

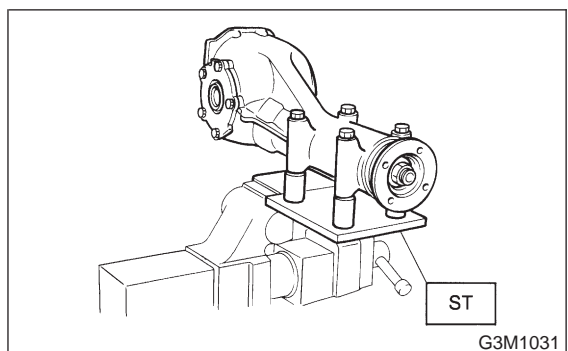

2) Drain gear oil by removing plug.

3) Remove the air breather cap.

NOTE:

Do not attempt to replace the air breather cap unless necessary.

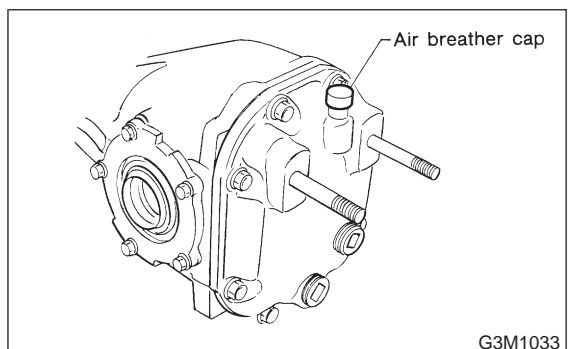

4) Remove rear cover by loosening retaining bolts.

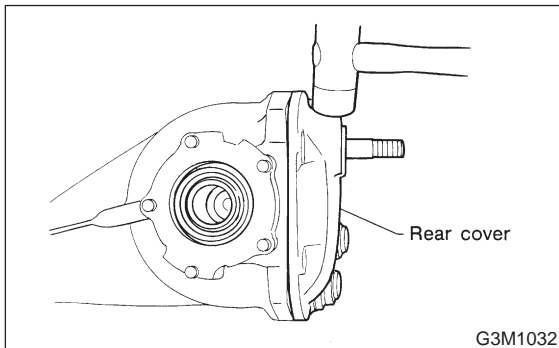

5) Make right and left side bearing retainers in order to identify them at reassembly. Remove side bearing retainer attaching bolts, set ST to differential carrier, and extract right and left side bearing retainers with a puller.

CAUTION:
Each shim, which is installed to adjust the side bearing preload, should be kept together with its mating retainer.

ST 398457700 ATTACHMENT

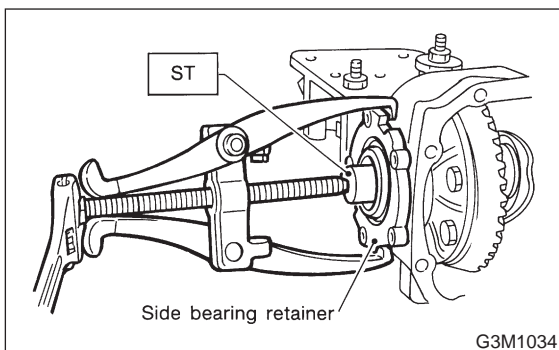

6) Pull out differential assembly from differential carrier.

CAUTION:
Be careful not to hit the teeth against the case.

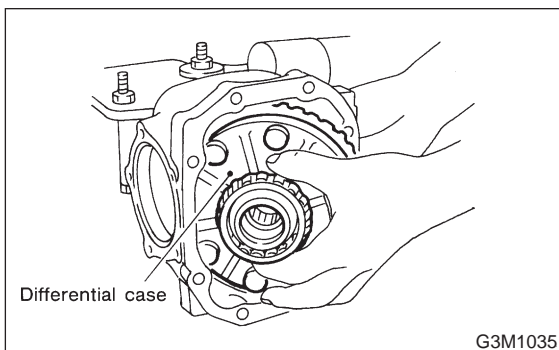

7) When replacing side bearing, pull bearing race from side bearing retainer using ST.
ST 398527700 PULLER ASSY

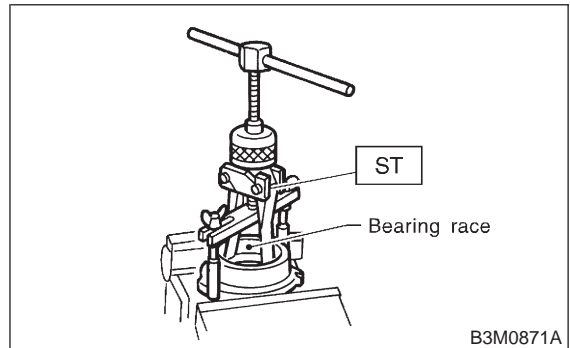

8) Extract bearing cone with ST.

CAUTION:
Do not attempt to disassemble the parts unless necessary.

NOTE:

- Set puller so that its claw catch the edge of the bearing cone.
- Never mix up the right and left hand bearing races and cones.

ST 399527700 PULLER SET

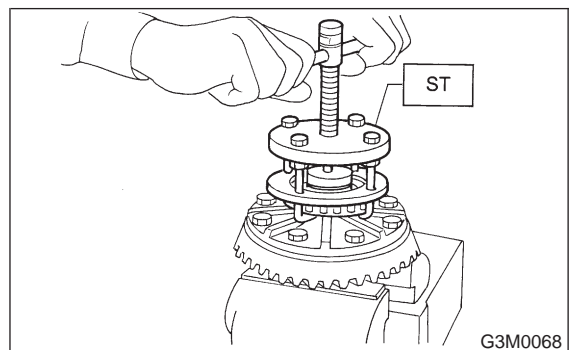

9) Remove crown gear by loosening crown gear bolts.

CAUTION:
Further disassembling is not allowed.

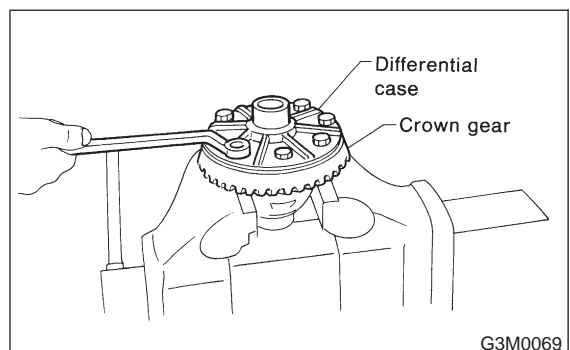

3-4 [W2C1]

2. Rear Differential

SERVICE PROCEDURE

10) Drive out pinion shaft lock pin from crown gear side.

NOTE:

The lock pin is staked at the pin hole end on the differential case; do not drive it out forcibly before unstaking it.

ST 899904100 STRAIGHT PIN REMOVER

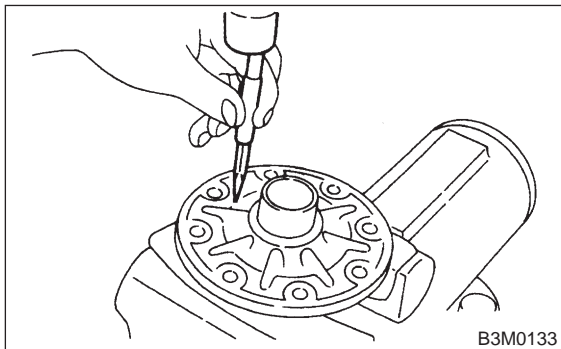

11) Draw out pinion mate shaft and remove pinion mate gears, side gears and thrust washers.

NOTE:

The gears as well as thrust washers should be marked or kept separated left and right, and front and rear.

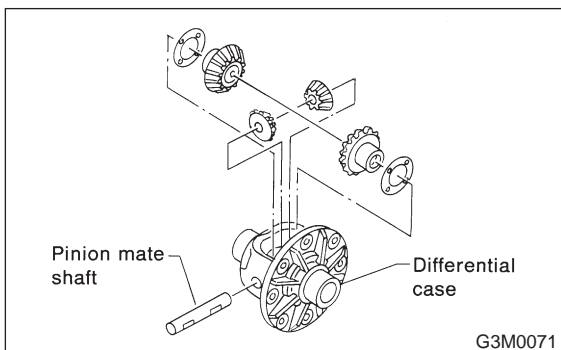

12) Hold companion flange with ST and remove drive pinion nut.

ST 498427200 FLANGE WRENCH

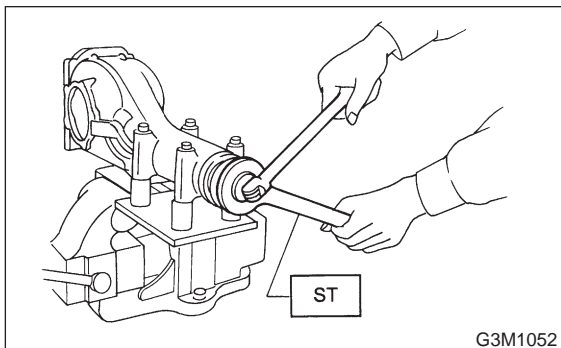

13) Extract the companion flange with a puller.

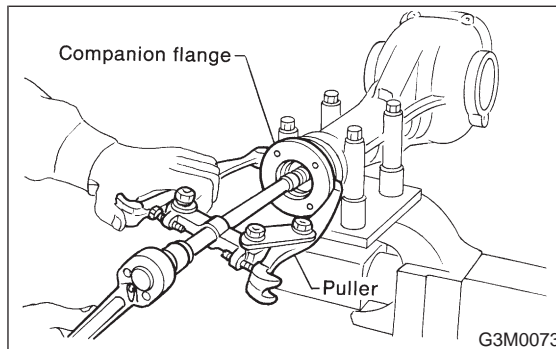

14) Press the end of drive pinion shaft and extract it together with rear bearing cone, preload adjusting spacer and washer.

NOTE:

Hold the drive pinion so as not to drop it.

ST 398467700 DRIFT

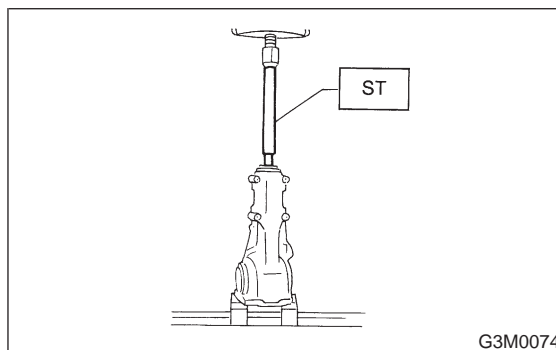

15) Remove rear bearing cone from drive pinion by supporting cone with ST.

NOTE:

Place the replacer so that its center-recessed side faces the pinion gear.

ST 498515500 REPLACER

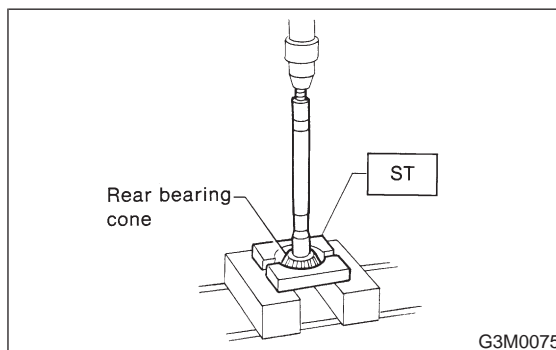

16) Remove front oil seal from differential carrier using ST.

ST 398527700 PULLER ASSY

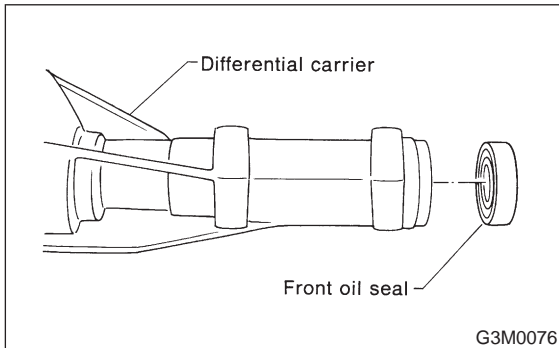

17) Remove pilot bearing together with front bearing cone using ST.

ST 398467700 DRIFT

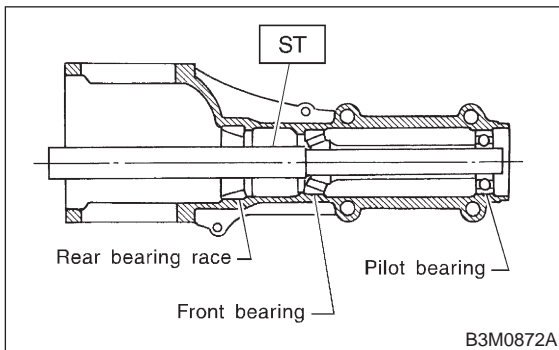

18) When replacing bearings, tap front bearing cup and rear bearing cup in this order out of case by using a brass bar.

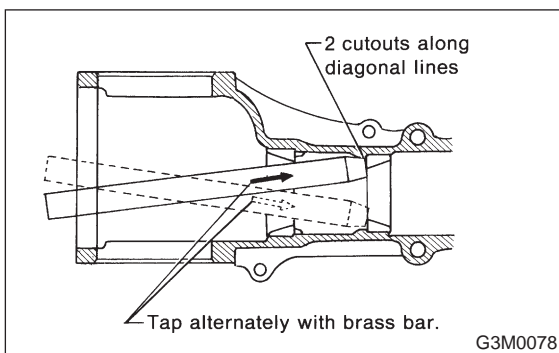

2. VA-TYPE

To detect real cause of trouble, inspect the following items before disassembling.

- Tooth contact of crown gear and pinion, and backlash
- Runout of crown gear at its back surface
- Turning resistance of drive pinion

1) Set ST on vise and install the differential assembly to ST.

ST 398217700 ATTACHMENT

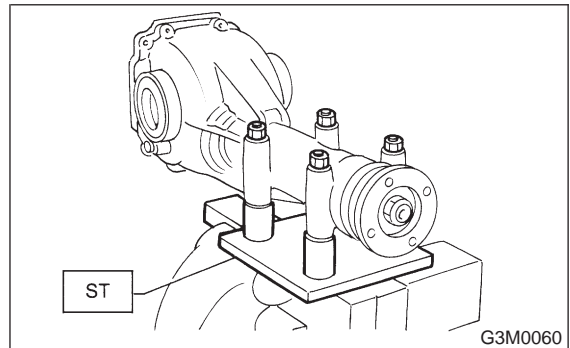

2) Drain gear oil by removing plug.

3) Remove rear cover by loosening retaining bolts.

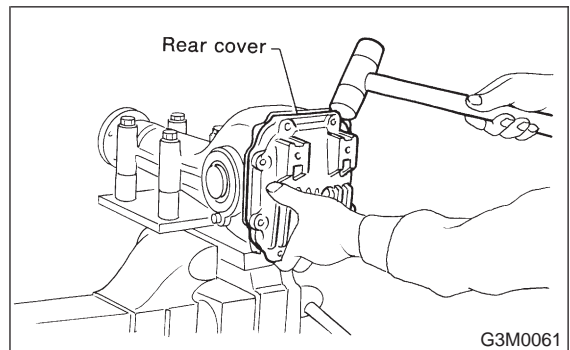

4) Replace air breather cap.

NOTE:

Do not attempt to replace the air breather cap unless necessary.

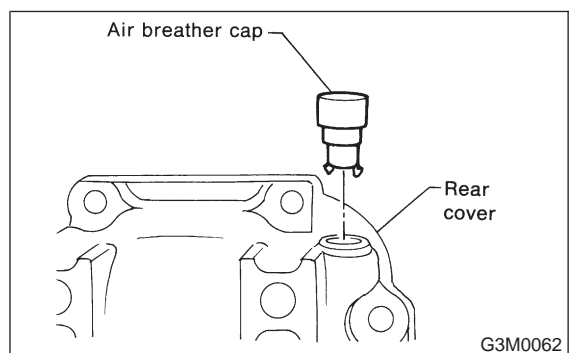

5) Remove right and left lock plates.

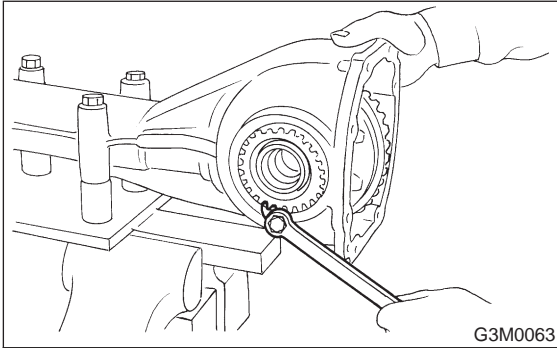

6) Remove right and left holders with ST.
ST 399780111 WRENCH

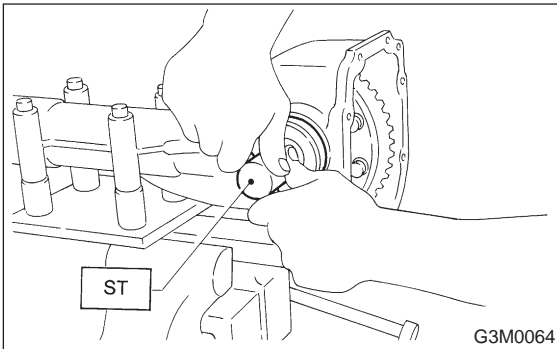

7) Pull out differential assembly from differential carrier.

CAUTION:
Be careful not to hit the teeth against the case.

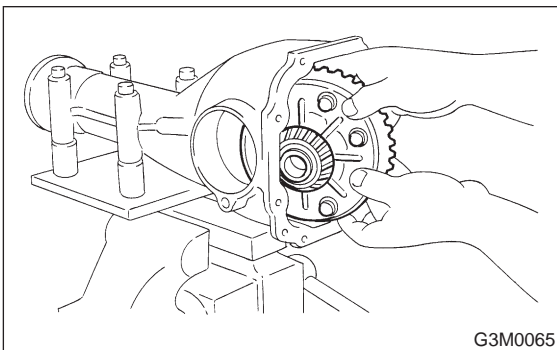

8) Remove bearing race from right and left holders with ST1 and ST2.

ST1 499705401 BEARING OUTER RACE PULLER ASSY
ST2 499705404 OUTER RACE PULLER SEAT

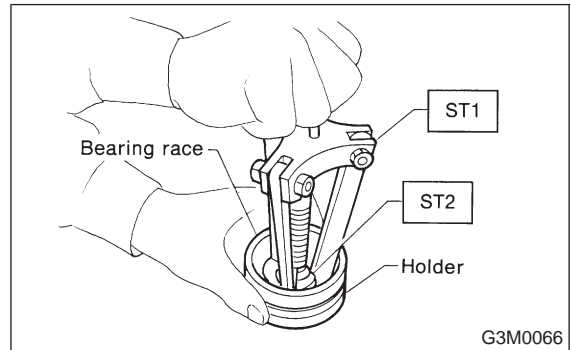

9) Remove oil seal from right and left holders with screwdriver.

CAUTION:
Perform this operation only when changing oil seal.

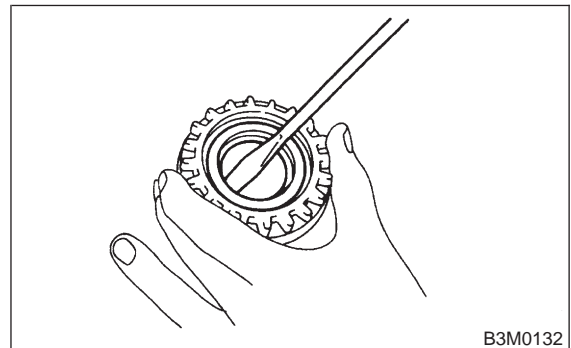

10) Extract bearing cone with ST.

CAUTION:
Do not attempt to disassemble the parts unless necessary.

NOTE:

- Set Puller so that its claws catch the edge of the bearing cone.
- Never mix up the right and left hand bearing cones.

ST 899524100 PULLER SET

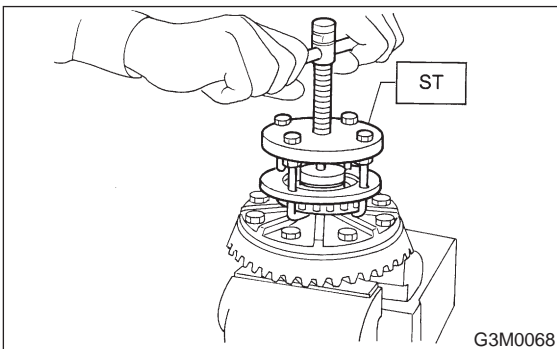

11) Remove crown gear by loosening crown gear bolts.

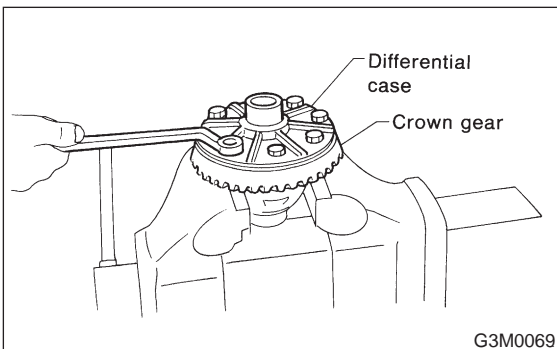

12) Drive out pinion shaft lock pin from crown gear side.

NOTE:

The lock pin is staked at the pin hole end on the differential case; do not drive it out forcibly before unstaking it.

ST 899904100 STRAIGHT PIN REMOVER

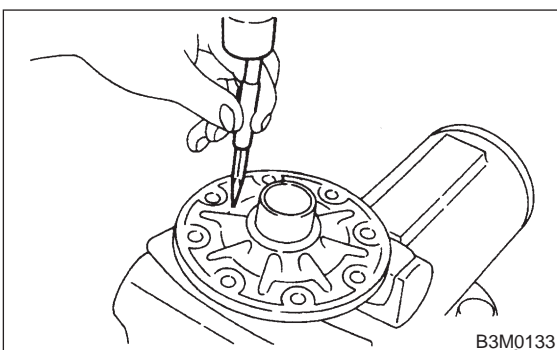

13) Draw out pinion mate shaft and remove pinion mate gears, side gears and thrust washers.

NOTE:

The gears as well as thrust washers should be marked or kept separated left and right, and front and rear.

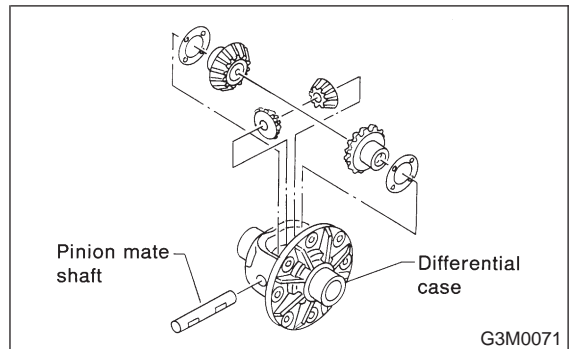

14) Hold companion flange with ST and remove drive pinion nut.

ST 498427200 FLANGE WRENCH

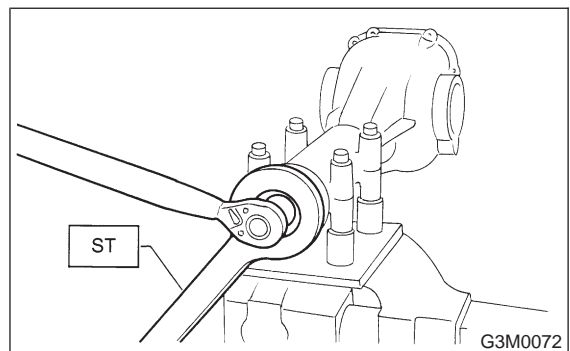

15) Extract the companion flange with a puller.

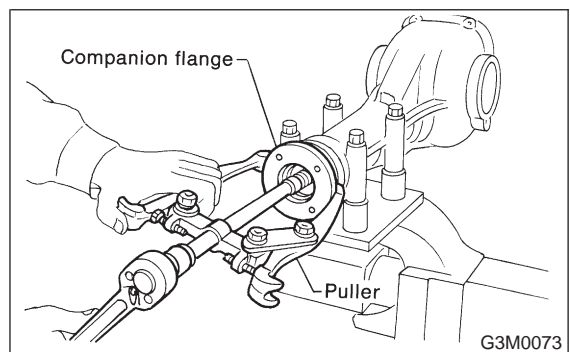

3-4 [W2D0]

2. Rear Differential

SERVICE PROCEDURE

16) Press the end of drive pinion shaft and extract it together with rear bearing cone, preload adjusting spacer and washer.

NOTE:

Hold the drive pinion so as not to drop it.

ST 398467700 DRIFT

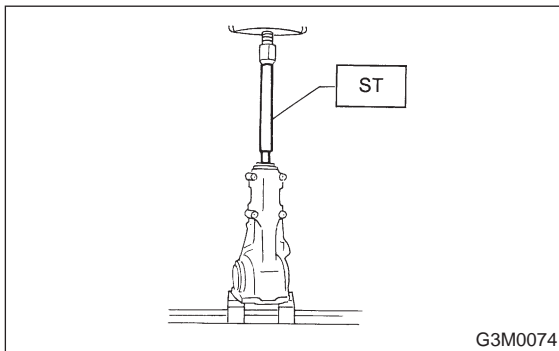

17) Remove rear bearing cone from drive pinion by supporting cone with ST.

NOTE:

Place the replacer so that its center-recessed side faces the pinion gear.

ST 498515500 REPLACER

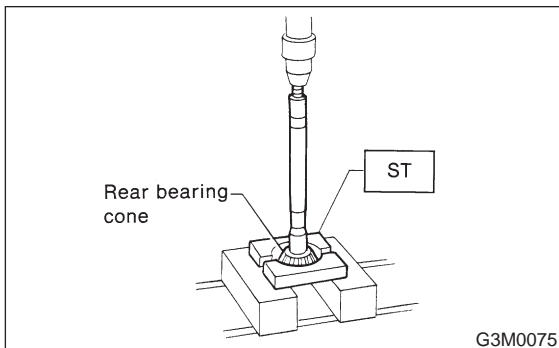

18) Remove front oil seal from differential carrier.

ST 499705401 PULLER ASSY

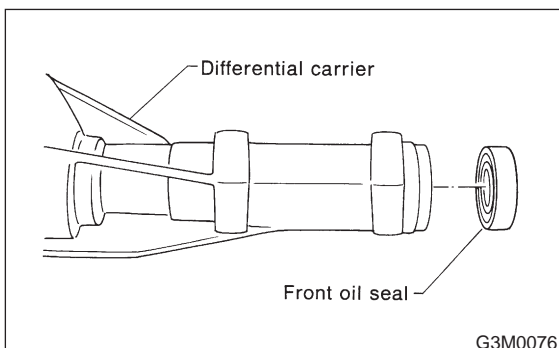

19) Remove pilot bearing together with front bearing cone using ST.

ST 398467700 DRIFT

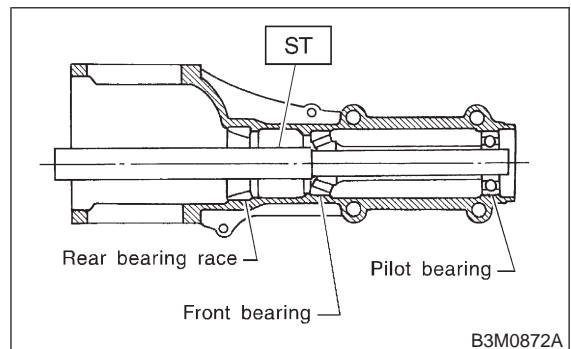

20) When replacing bearings, tap front bearing race and rear bearing race in this order out of case by using a brass bar.

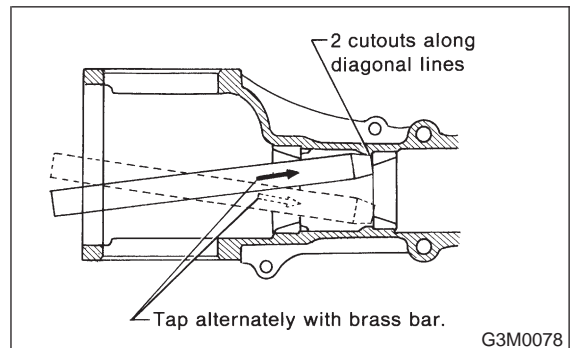

D: INSPECTION

Wash all the disassembled parts clean, and examine them for wear, damage, or other defects. Repair or replace defective parts as necessary.

1) Crown gear and drive pinion

- If abnormal tooth contact is evident, find out the cause and adjust to give correct tooth contact at assembly. Replace the gear if excessively worn or incapable of adjustment.

- If crack, score, or seizure is evident, replace as a set. Slight damage of tooth can be corrected by oil stone or the like.

2) Side gear and pinion mate gear

- Replace if crack, score, or other defects are evident on tooth surface.

- Replace if thrust washer contacting surface is worn or seized. Slight damage of the surface can be corrected by oil stone or the like.

3) Bearing

Replace if seizure, peeling, wear, rust, dragging during rotation, abnormal noise or other defect is evident.

4) Thrust washers of side gear and pinion mate gear Replace if seizure, flaw, abnormal wear or other defect is evident.

5) Oil seal

Replace if deformed or damaged, and at every disassembling.

6) Differential carrier

Replace if the bearing bores are worn or damaged.

7) Differential case

Replace if its sliding surfaces are worn or cracked.

8) Companion flange

Replace if the oil seal lip contacting surfaces have flaws.

E: ASSEMBLY

1. T-TYPE

1) Precautions for assembling

- Assemble in the reverse order of disassembling.
- Check and adjust each part during assembly.
- Keep the shims and washers in order, so that they are not misinstalled.
- Thoroughly clean the surfaces on which the shims, washers and bearings are to be installed.
- Apply gear oil when installing the bearings and thrust washers.
- Be careful not to mix up the right and left hand races of the bearings.
- Replace the oil seal with new one at every disassembly. Apply chassis grease between the lips when installing the oil seal.

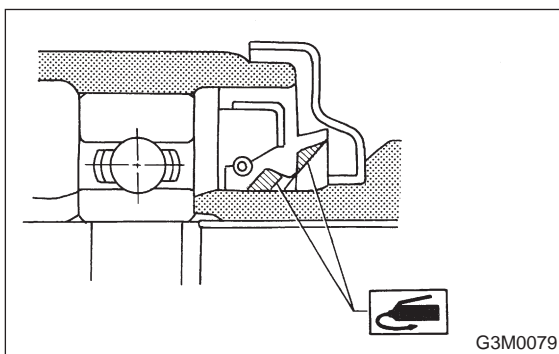

2) Adjusting preload for front and rear bearings
Adjust the bearing preload with spacer and washer between front and rear bearings. Pinion height adjusting washers are not affected by this adjustment. The adjustment must be carried out without the oil seal inserted.

(1) Press rear bearing race into differential carrier with ST1 and ST2.

ST1 398477701 HANDLE

ST2 398427703 DRIFT 2

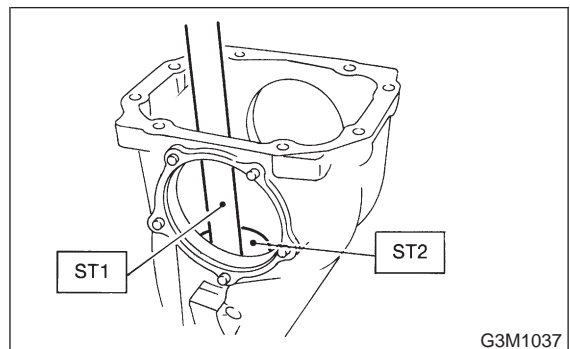

(2) Insert ST1 into carrier with pinion height adjusting washer and rear bearing cone fitted onto it.

CAUTION:

- Re-use the used washer if not deformed.
- Use a new rear bearing cone.

(3) Then install preload adjusting spacer and washer, front bearing cone, ST2, companion flange, and washer and drive pinion nut.

ST1 398507702 DUMMY SHAFT

ST2 398507703 DUMMY COLLAR

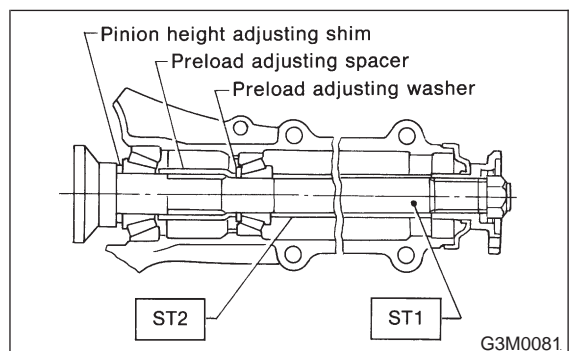

3-4 [W2E1]

2. Rear Differential

SERVICE PROCEDURE

(4) Turn ST1 with hand to make it seated, and tighten drive pinion nut while measuring the preload with spring balance. Select preload adjusting washer and spacer so that the specified preload is obtained when nut is tightened to the specified torque with ST2.

ST1 398507704 BLOCK

ST2 398507702 DUMMY SHAFT

CAUTION:

Use a new lock nut.

NOTE:

- Be careful not to give excessive preload.
- When tightening the drive pinion nut, lock ST1 with ST2 as shown in the figure.

Tightening torque:

$181 \pm 15 \text{ N}\cdot\text{m}$ ($18.5 \pm 1.5 \text{ kg}\cdot\text{m}$, $134 \pm 11 \text{ ft}\cdot\text{lb}$)

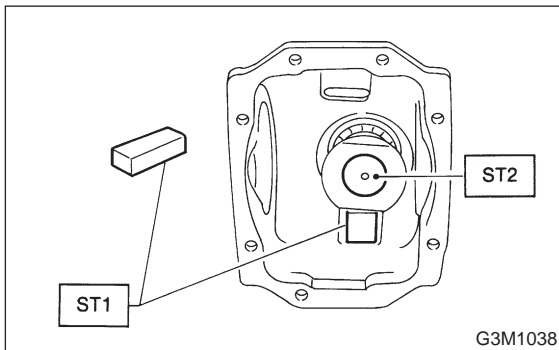

Front and rear bearing preload

For new bearing:
 $17.7 - 25.5 \text{ N}$ ($1.8 - 2.6 \text{ kg}$, $4.0 - 5.7 \text{ lb}$)
 at companion flange bolt hole

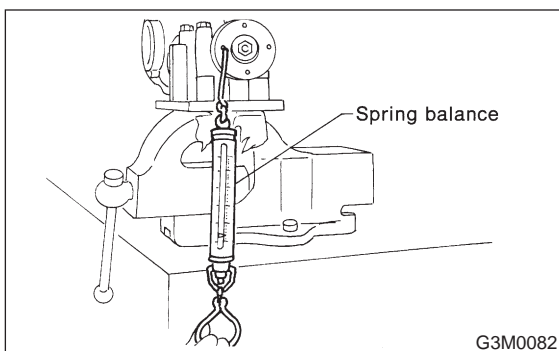

Preload adjusting washer	Part No.	Thickness mm (in)
	383705200	2.59 (0.1020)
	383715200	2.57 (0.1012)
	383725200	2.55 (0.1004)
	383735200	2.53 (0.0996)
	383745200	2.51 (0.0988)
	383755200	2.49 (0.0980)
	383765200	2.47 (0.0972)
	383775200	2.45 (0.0965)
	383785200	2.43 (0.0957)
	383795200	2.41 (0.0949)
	383805200	2.39 (0.0941)
	383815200	2.37 (0.0933)
	383825200	2.35 (0.0925)
	383835200	2.33 (0.0917)
383845200	2.31 (0.0909)	
Preload adjusting spacer	Part No.	Length mm (in)
	383695201	56.2 (2.213)
	383695202	56.4 (2.220)
	383695203	56.6 (2.228)
	383695204	56.8 (2.236)
	383695205	57.0 (2.244)
	383695206	57.2 (2.252)

3) Adjusting drive pinion height

Adjust drive pinion height with shim installed between rear bearing cone and the back of pinion gear.

(1) Install ST1, ST2 and ST3, as shown in the figure, and apply the specified preload on the bearings.

Front and rear bearing preload
For new bearing: 17.7 — 25.5 N (1.8 — 2.6 kg, 4.0 — 5.7 lb) at companion flange bolt hole

Adjust preload for front and rear bearings.

NOTE:

At this time, install a pinion height adjusting shim which is temporarily selected or the same as that used before.

- ST1 398507702 DUMMY SHAFT
- ST2 398507703 DUMMY COLLAR
- ST3 398507701 DIFFERENTIAL CARRIER GAUGE

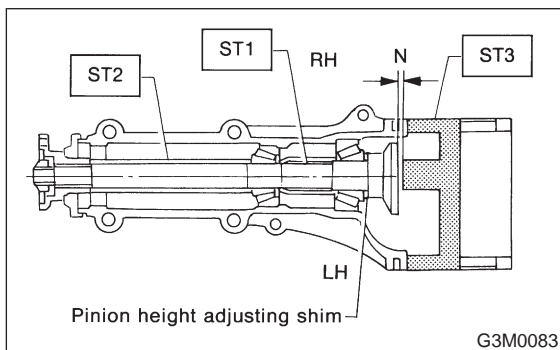

(2) Measure the clearance “N” between the end of ST3 and the end surface of ST1 by using a thickness gauge.

NOTE:

Make sure there is no clearance between the carrier and ST3.

- ST1 398507702 DUMMY SHAFT
- ST2 398507703 DUMMY COLLAR
- ST3 398507701 DIFFERENTIAL CARRIER GAUGE

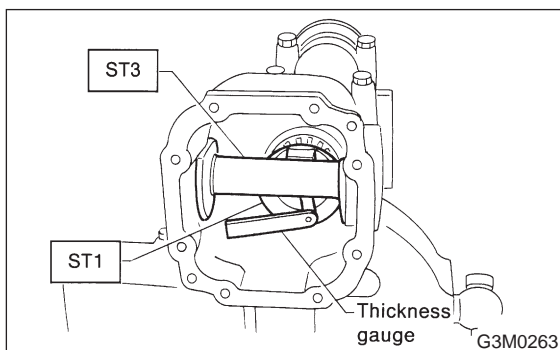

(3) Obtain the thickness of pinion height adjusting shim to be inserted from the following formula, and replace the temporarily installed shim with this one.

$$T = T_o + N - (H \times 0.01) - 0.20 \text{ (mm)}$$

Where:

T = Thickness of pinion height adjusting shim (mm)

T_o = Thickness of shim temporarily inserted (mm)

N = Reading of thickness gauge (mm)

H = Figure marked on drive pinion head

(Example of calculation)

$$T_o = 2.20 + 1.20 = 3.40 \text{ mm}$$

$$N = 0.23 \text{ mm } H = + 1,$$

$$T = 3.40 + 0.23 - 0.01 - 0.20 = 3.42$$

Result: Thickness = 3.42 mm

Therefore use the shim 383605200.

Pinion height adjusting shim	
Part No.	Thickness mm (in)
383495200	3.09 (0.1217)
383505200	3.12 (0.1228)
383515200	3.15 (0.1240)
383525200	3.18 (0.1252)
383535200	3.21 (0.1264)
383545200	3.24 (0.1276)
383555200	3.27 (0.1287)
383565200	3.30 (0.1299)
383575200	3.33 (0.1311)
383585200	3.36 (0.1323)
383595200	3.39 (0.1335)
383605200	3.42 (0.1346)
383615200	3.45 (0.1358)
383625200	3.48 (0.1370)
383635200	3.51 (0.1382)
383645200	3.54 (0.1394)
383655200	3.57 (0.1406)
383665200	3.60 (0.1417)
383675200	3.63 (0.1429)
383685200	3.66 (0.1441)

4) Install the selected pinion height adjusting shim on drive pinion, and press the rear bearing cone into position with ST.

ST 398177700 INSTALLER

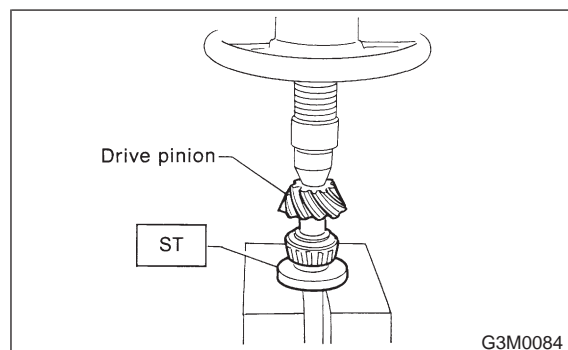

3-4 [W2E1]

2. Rear Differential

SERVICE PROCEDURE

5) Insert drive pinion into differential carrier, install the previously selected bearing preload adjusting spacer and washer.

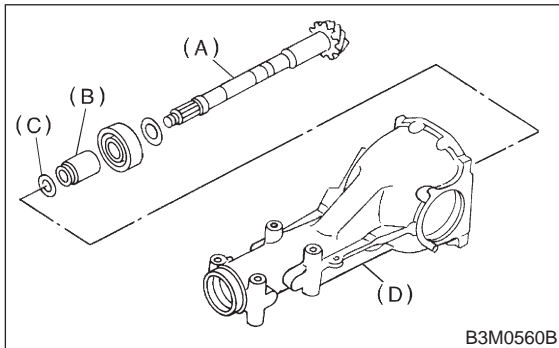

- (A) Drive pinion
- (B) Bearing preload adjusting spacer
- (C) Washer
- (D) Differential carrier

6) Press-fit front bearing cone into case with ST1, ST2 and ST3.

ST1 398507703 DUMMY COLLAR
ST2 399780104 WEIGHT
ST3 899580100 INSTALLER

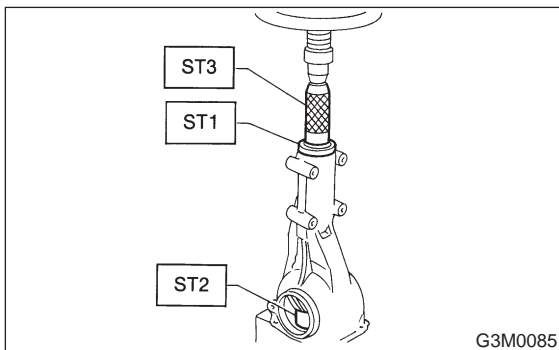

7) Insert spacer, then press-fit pilot bearing with ST1 and ST2.

ST1 399780104 WEIGHT
ST2 899580100 INSTALLER

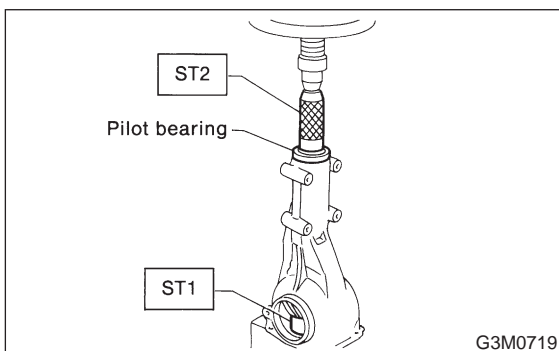

8) Fit a new oil seal with ST.

NOTE:

- Press-fit until end of oil seal is 1 mm (0.04 in) inward from end of carrier.

- Apply grease between the oil seal lips.

ST 498447120 OIL SEAL INSTALLER

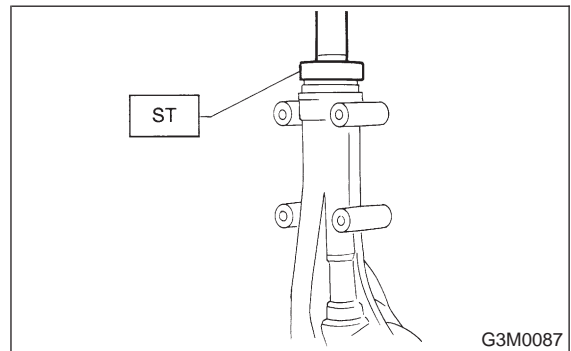

9) Press-fit companion flange with ST1 and ST2.

CAUTION:

Be careful not to damage bearing.

ST1 899874100 INSTALLER
ST2 399780104 WEIGHT

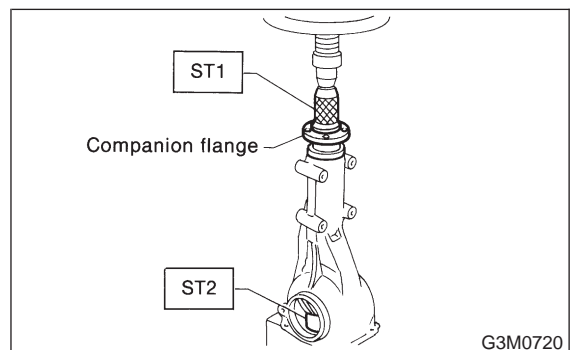

10) Install self-locking nut. Then tighten it with ST.

ST 498427200 FLANGE WRENCH

Tightening torque:

181±15 N·m (18.5±1.5 kg·m, 134±11 ft·lb)

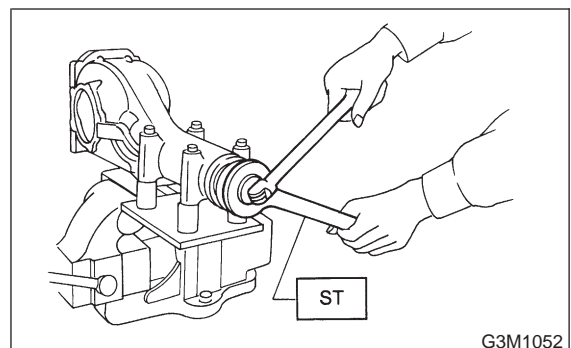

11) Assembly of differential case

12) Install side gears and pinion mate gears, with their thrust washers and pinion mate shaft, into differential case.

CAUTION:

- Apply gear oil on both sides of the washer and on the side gear shaft before installing.
- Insert the pinion mate shaft into the differential case by aligning the lock pin holes.

- (1) Measure the clearance between differential case and the back of side gear.
- (2) Adjust the clearance as specified by selecting side gear thrust washer.

Side gear backlash:

0.1 — 0.2 mm (0.004 — 0.008 in)

Part No.	Thickness mm (in)
383445201	0.75 — 0.80 (0.0295 — 0.0315)
383445202	0.80 — 0.85 (0.0315 — 0.0335)
383445203	0.85 — 0.90 (0.0335 — 0.0354)
383445204	0.90 — 0.95 (0.0354 — 0.0374)
383445205	0.95 — 1.0 (0.0374 — 0.0394)

- (3) Check the condition of rotation after applying oil to the gear tooth surfaces and thrust surfaces.
- (4) After inserting pinion shaft lock pin into differential case, stake the both sides of the hole to prevent pin from falling off.
- (5) Install crown gear on differential case.

CAUTION:

Before installing bolts, apply Lock Tite to bolt threads.

Lock Tite:

THREE BOND 1324 or equivalent

NOTE:

Tighten diagonally while tapping the bolt heads.

Tightening torque:

103±10 N·m (10.5±1.0 kg·m, 76±7 ft·lb)

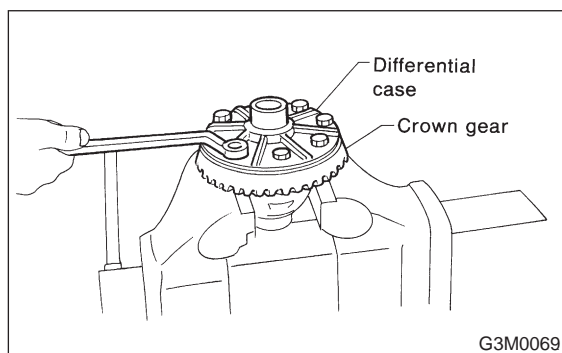

- 13) Press side bearing cone onto differential case with ST1.

ST1 398487700 DRIFT

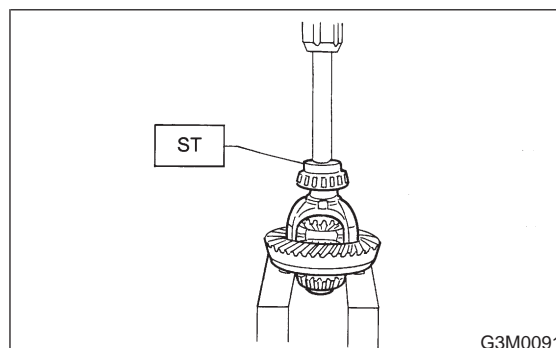

- 14) Adjusting side bearing retainer shims

- (1) The drive gear backlash and side bearing preload can be determined by the side bearing retainer shim thickness.
- (2) Install the differential case assembly into differential carrier in the reverse order of disassembly.

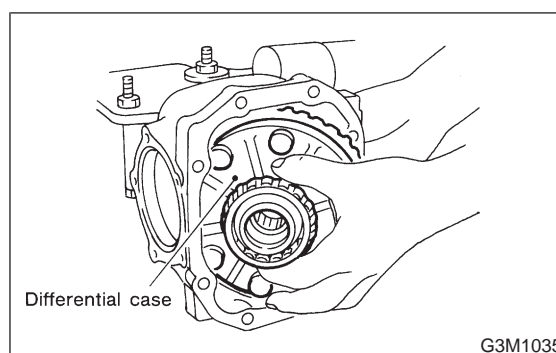

- (3) Install side retainer shims and O-rings to the left and right retainers from which they were removed.

NOTE:

- Replace broken or cracked O-ring with new one.
- Replace broken or corroded side retainer shim with new one of same thickness.

Side bearing retainer shim	
Part No.	Thickness mm (in)
383475201	0.20 (0.0079)
383475202	0.25 (0.0098)
383475203	0.30 (0.0118)
383475204	0.40 (0.0157)
383475205	0.50 (0.0197)

3-4 [W2E1]

2. Rear Differential

SERVICE PROCEDURE

(4) Align arrow marked on differential carrier with that marked on side retainer during installation.

CAUTION:

Be careful that side bearing cup is not damaged by bearing roller.

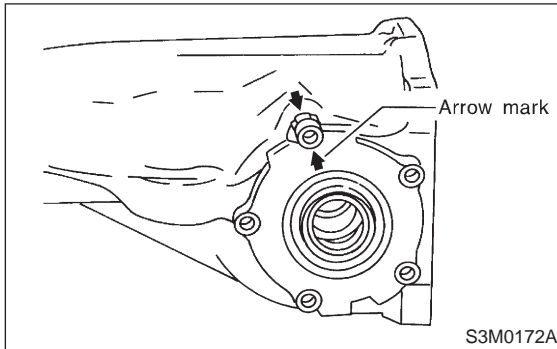

(5) Tighten side bearing retainer bolts.

CAUTION:

Before tightening the two side bearing retainer bolts, apply Lock Tite to bolt threads.

⇒ **Lock Tite:**

THREE BOND 1105 or equivalent

Tightening torque:

10.3±1.5 N·m (1.05±0.15 kg-m, 7.6±1.1 ft-lb)

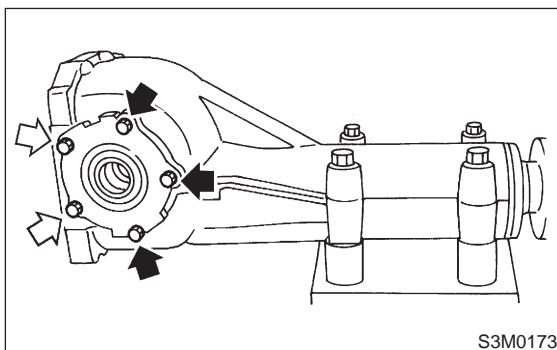

(6) Measure the crown gear-to-drive pinion backlash.

Set magnet base on differential carrier. Align contact point of dial gauge with tooth face of crown gear, and move crown gear while holding drive pinion still. Read value indicated on dial gauge.

Backlash:

0.10 — 0.20 mm (0.0039 — 0.0079 in)

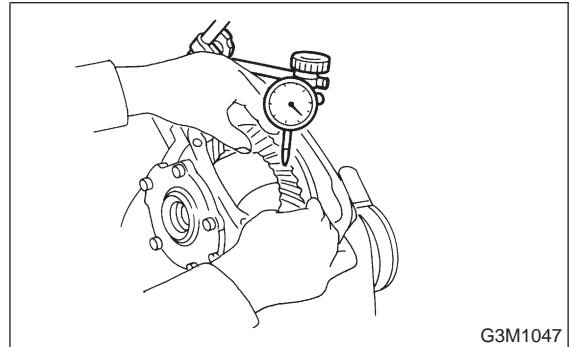

(7) At the same time, measure the turning resistance of drive pinion. Compared with the resistance when differential case is not installed, if the increase of the resistance is not within the specified range, readjust side bearing retainer shims.

NOTE:

If measured backlash is not within specified range, repeat procedure for adjustment of side bearing retainer shims.

Turning resistance increase:

2.9 — 10.8 N (0.3 — 1.1 kg, 0.7 — 2.4 lb)

15) Re-check crown gear-to-pinion backlash.

Backlash:

0.10 — 0.20 mm (0.0039 — 0.0079 in)

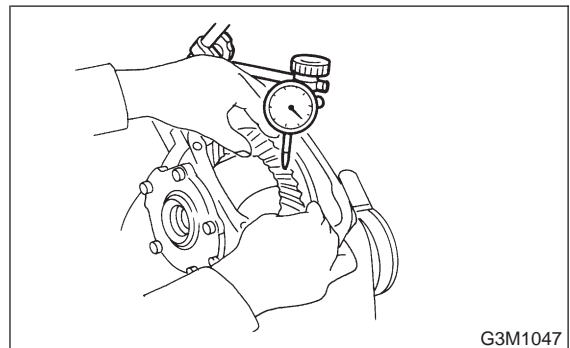

16) Check the crown gear runout on its back surface, and make sure pinion and crown gear rotate smoothly.

Limit of runout:

Less than 0.05 mm (0.0020 in)

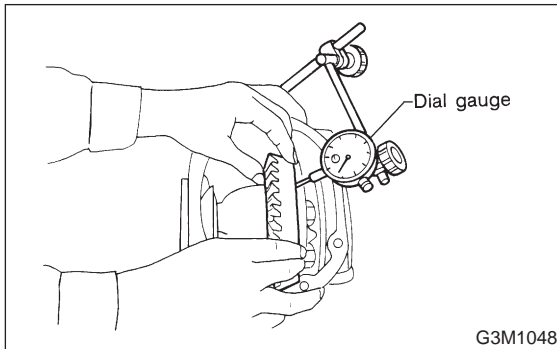

17) Checking and adjusting tooth contact of crown gear

(1) Apply an even coat of red lead on both sides of three or four teeth on the crown gear. Check the contact pattern after rotating crown gear several revolutions back and forth until a definite contact pattern appears on the crown gear.

(2) When the contact pattern is incorrect, readjust according to the instructions given in "TOOTH CONTACT PATTERN".

NOTE:

Be sure to wipe off red lead completely after adjustment is completed.

18) If proper tooth contact is not obtained, once again adjust the drive pinion height, changing RH and LH side bearing retainer shims and the hypoid gear backlash.

(1) Drive pinion height

ST1 398507702 DUMMY SHAFT

ST2 398507701 DIFFERENTIAL CARRIER GAUGE

$$T = To + N - (H \times 0.01) - 0.20 \text{ (mm)}$$

Where:

T = Thickness of pinion height adjusting shim (mm)

To = Thickness of shim temporarily inserted (mm)

N = Reading of thickness gauge (mm)

H = Figure marked on drive pinion head

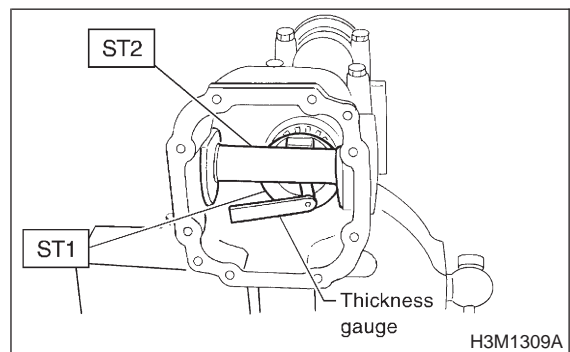



(2) Hypoid gear backlash

Backlash:

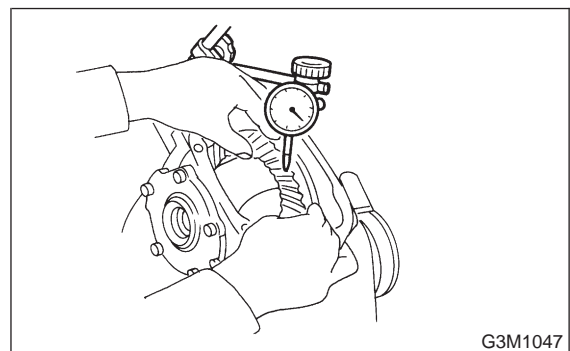
0.10 — 0.20 mm (0.0039 — 0.0079 in)

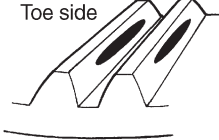
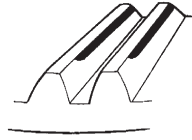
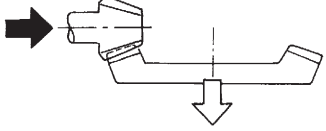
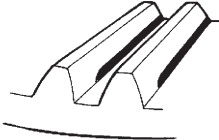
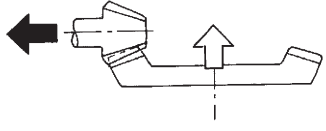
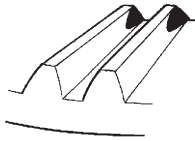
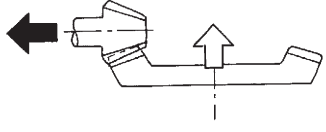

➡ : Adjusting direction of drive pinion
⇨ : Adjusting direction of crown gear

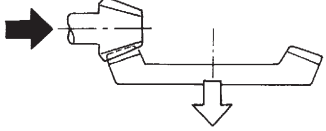
TOOTH CONTACT PATTERN		
Condition	Contact pattern	Adjustment
<p>Correct tooth contact Tooth contact pattern slightly shifted towards toe under no load rotation. (When loaded, contact pattern moves toward heel.)</p>	<p>Toe side Heel side</p>  <p>B3M0317A</p>	<p>—</p>
<p>Face contact Backlash is too large.</p>	<p>This may cause noise and chipping at tooth ends.</p>  <p>B3M0319</p>	<p>Increase thickness of drive pinion height adjusting shim in order to bring drive pinion closer to crown gear center.</p>  <p>B3M0323</p>
<p>Flank contact Backlash is too small.</p>	<p>This may cause noise and stepped wear on surfaces.</p>  <p>B3M0320</p>	<p>Reduce thickness of drive pinion height adjusting shim in order to move drive pinion away from crown gear.</p>  <p>B3M0324</p>
<p>Toe contact Contact area is small.</p>	<p>This may cause chipping at toe ends.</p>  <p>B3M0321</p>	<p>Adjust as for flank contact.</p>  <p>B3M0324</p>
<p>Heel contact Contact area is small.</p>	<p>This may cause chipping at heel ends.</p>  <p>B3M0322</p>	<p>Adjust as for face contact.</p>  <p>B3M0323</p>

19) Install rear cover and tighten bolts to specified torque.

Tightening torque:

$29 \pm 5 \text{ N}\cdot\text{m}$ ($3.0 \pm 0.5 \text{ kg}\cdot\text{m}$, $21.7 \pm 3.6 \text{ ft}\cdot\text{lb}$)

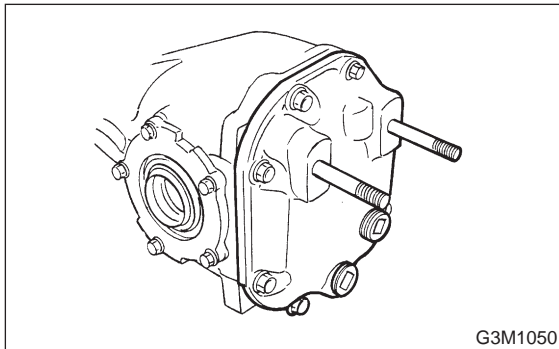

2. VA-TYPE

1) Precautions for assembling

- Assemble in the reverse order of disassembling.
- Check and adjust each part during assembly.
- Keep the shims and washers in order, so that they are not misinstalled.
- Thoroughly clean the surfaces on which the shims, washers and bearings are to be installed.
- Apply gear oil when installing the bearings and thrust washers.
- Be careful not to mix up the right and left hand races of the bearings.
- Replace the oil seal with new one at every disassembly. Apply chassis grease between the lips when installing the oil seal.

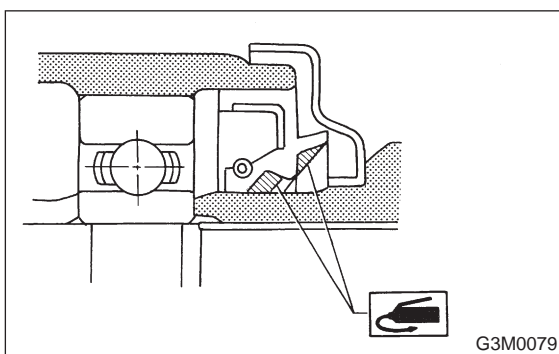

2) Adjust preload for front and rear bearings. Adjust the bearing preload with spacer and washer between front and rear bearings. Pinion height adjusting washer are not affected by this adjustment. The adjustment must be carried out without oil seal inserted.

(1) Press rear bearing race into differential carrier with ST1 and ST2.

ST1 398477701 HANDLE

ST2 398477702 DRIFT

(2) Press front bearing race into differential carrier with ST1 and ST2.

ST1 398477701 HANDLE

ST2 498447110 BEARING OUTER RACE DRIFT

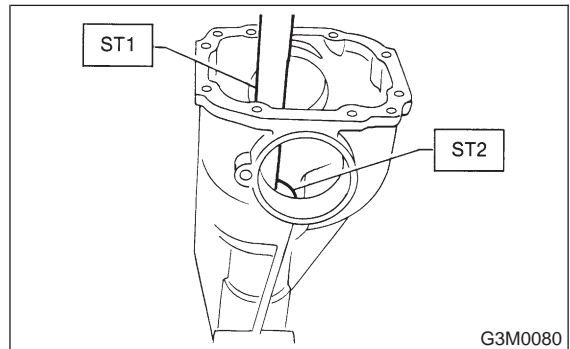

(3) Insert front bearing cone.

CAUTION:

Use a new front bearing cone.

(4) Insert ST into carrier with pinion height adjusting shim and rear bearing cone fitted onto it.

CAUTION:

- Re-use the used washer if not deformed.
- Use a new rear bearing cone.

ST 498447150 DUMMY SHAFT

(5) Then install preload adjusting spacer and washer, front bearing cone, ST2, companion flange, and washer and drive pinion nut.

ST1 498447150 DUMMY SHAFT

ST2 32285AA000 DUMMY COLLAR

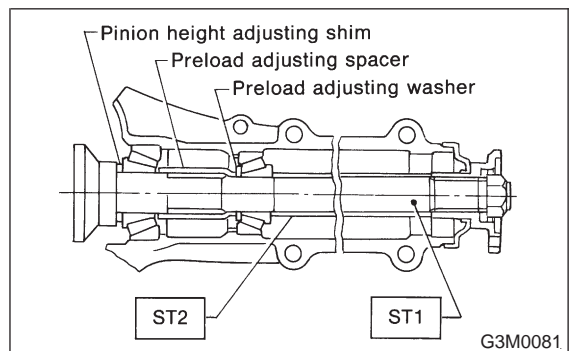

3-4 [W2E2]

2. Rear Differential

SERVICE PROCEDURE

(6) Turn ST1 with hand to make it seated, and tighten drive pinion nut while measuring the preload with spring balance. Select preload adjusting washer and spacer so that the specified preload is obtained when nut is tightened to the specified torque with ST2.

CAUTION:

Use a new lock nut.

NOTE:

- Be careful not to give excessive preload.
- When tightening the drive pinion nut, lock ST1 with ST2.

ST1 398507704 BLOCK

ST2 498447150 DUMMY SHAFT

Tightening torque:

188±26 N-m (19.2±2.7 kg-m, 139±20 ft-lb)

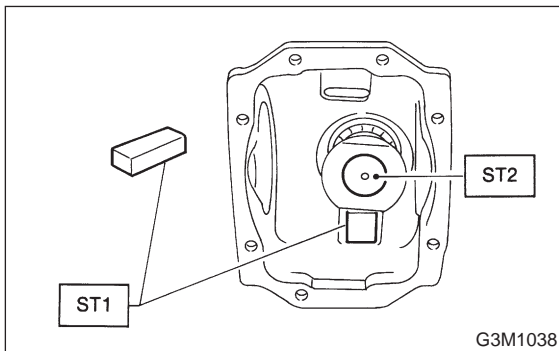

Front and rear bearing preload

For new bearing:

12.7 — 32.4 N (1.3 — 3.3 kg, 2.9 — 7.3 lb)
at companion flange bolt hole

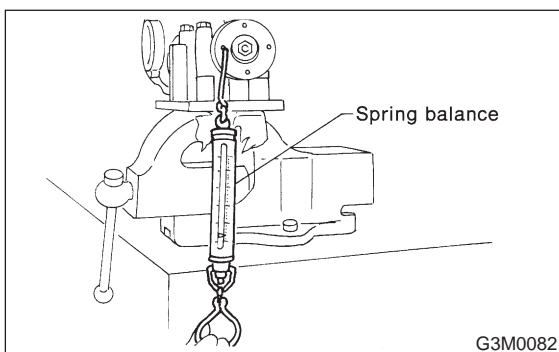

	Part No.	Thickness mm (in)
	Preload adjusting washer	38336AA000
38336AA120		1.513 (0.0596)
38336AA010		1.525 (0.0600)
38336AA130		1.538 (0.0606)
38336AA020		1.550 (0.0610)
38336AA140		1.563 (0.0615)
38336AA030		1.575 (0.0620)
38336AA150		1.588 (0.0625)
38336AA040		1.600 (0.0630)
38336AA160		1.613 (0.0635)
38336AA050		1.625 (0.0640)
38336AA170		1.638 (0.0645)
38336AA060		1.650 (0.0650)
38336AA180		1.663 (0.0655)
38336AA070		1.675 (0.0659)
38336AA190		1.688 (0.0665)
38336AA080		1.700 (0.0669)
38336AA200	1.713 (0.0674)	
38336AA090	1.725 (0.0679)	
38336AA210	1.738 (0.0684)	
38336AA100	1.750 (0.0689)	
38336AA220	1.763 (0.0694)	
38336AA110	1.775 (0.0699)	
	Part No.	Length mm (in)
	Preload adjusting spacer	32288AA040
32288AA050		52.5 (2.067)
31454AA100		52.6 (2.071)
32288AA060		52.7 (2.075)
31454AA110		52.8 (2.079)
32288AA070		52.9 (2.083)
31454AA120		53.0 (2.087)
32288AA080		53.1 (2.091)
32288AA090		53.3 (2.098)

3) Adjusting drive pinion height Adjust drive pinion height with shim installed between rear bearing cone and the back of pinion gear.

(1) Install ST1, ST2 and ST3, as shown in the figure, and apply the specified preload on the bearings.

Front and rear bearing preload

For new bearing:

12.7 — 32.4 N (1.3 — 3.3 kg, 2.9 — 7.3 lb)
at companion flange bolt hole

Adjust preload for front and rear bearings.

NOTE:

At this time, install an original pinion height adjusting shim.

- ST1 498447150 DUMMY SHAFT
- ST2 32285AA000 DUMMY COLLAR
- ST3 498505501 DIFFERENTIAL CARRIER GAUGE

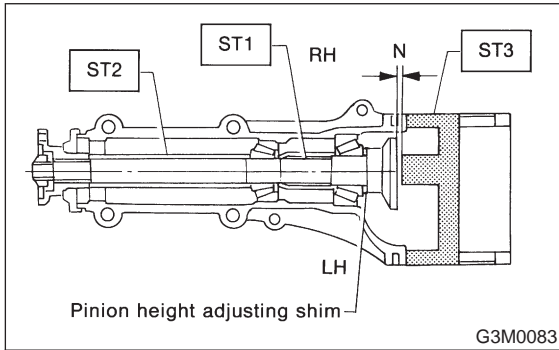

(2) Measure the clearance “N” between the end of ST2 and the end surface of ST1 by using a thickness gauge.

NOTE:

Make sure there is no clearance between ST2 and ST1.

- ST1 498447150 DUMMY SHAFT
- ST2 498505501 DIFFERENTIAL CARRIER GAUGE

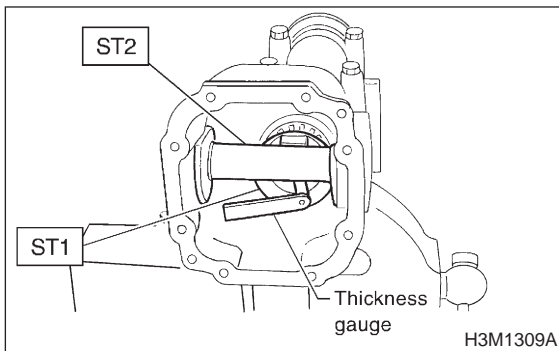

(3) Obtain the thickness of pinion height adjusting washer to be inserted from the following formula, and replace the temporarily installed shim with this one.

NOTE:

Use 1 to 3 shims as required for adjustment.

$$T = T_o + N - 0.05 \text{ (mm)}$$

where

T = Thickness of pinion height adjusting shim (mm)

T_o = Thickness of shim originally installed (mm)

N = Reading of thickness gauge (mm)

(Example of calculation)

$$T_o = 0.15 \text{ mm}$$

$$N = 0.1 \text{ mm}$$

$$T = 0.15 + 0.1 - 0.05 = 0.2 \text{ mm}$$

Result: Thickness = 0.2 mm

Therefore use the 32295AA220.

Pinion height adjusting shim	
Part No.	Thickness mm (in)
32295AA200	0.150 (0.0059)
32295AA210	0.175 (0.0069)
32295AA220	0.200 (0.0079)
32295AA230	0.225 (0.0089)
32295AA240	0.250 (0.0098)
32295AA250	0.275 (0.0108)

3-4 [W2E2]

2. Rear Differential

SERVICE PROCEDURE

4) Install the selected pinion height adjusting shim on drive pinion, and press the rear bearing cone into position with ST.

ST 498175500 INSTALLER

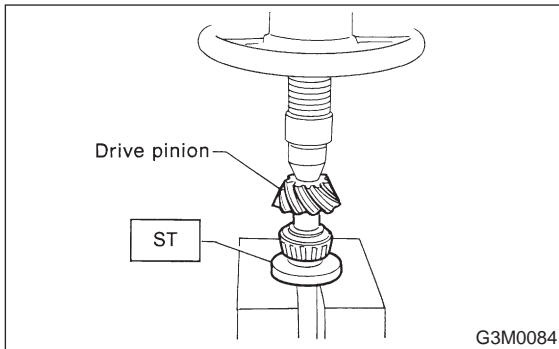

5) Insert drive pinion into differential carrier, install the previously selected bearing preload adjusting spacer and washer.

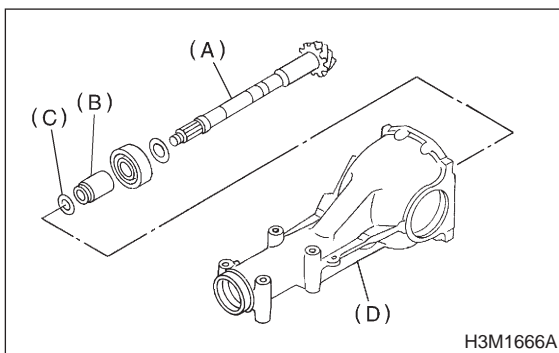

- (A) Drive pinion
- (B) Adjusting spacer
- (C) Washer
- (D) Differential carrier

6) Press-fit front bearing cone into case with ST1, ST2 and ST3.

ST1 32285AA000 DUMMY COLLAR

ST2 399780104 WEIGHT

ST3 899580100 INSTALLER

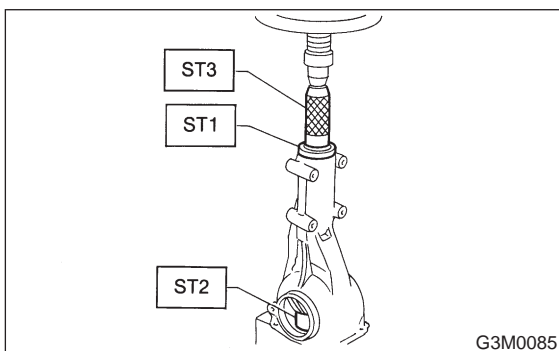

7) Insert spacer, then press-fit pilot bearing with ST1 and ST2.

ST1 399780104 WEIGHT

ST2 899580100 INSTALLER

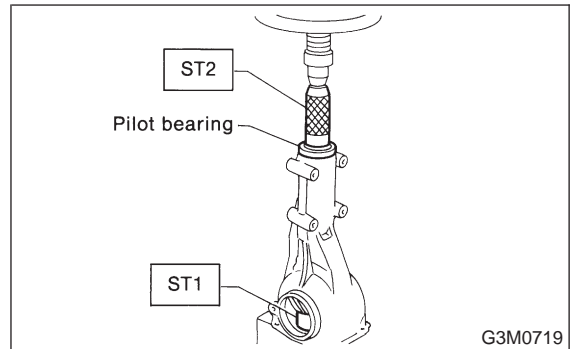

8) Fit a new oil seal with ST.

NOTE:

- Press-fit until end of oil seal is 1 mm (0.04 in) inward from end of carrier.
- Apply grease between the oil seal lips.

ST 498447120 OIL SEAL INSTALLER

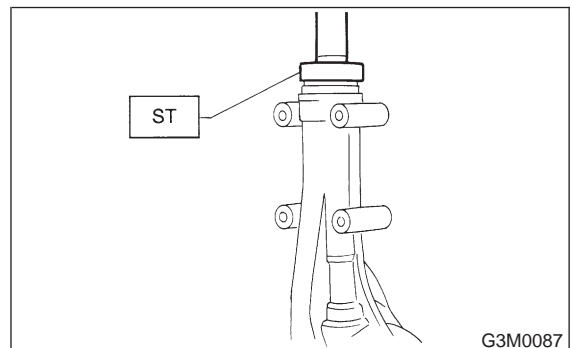

9) Press-fit companion flange with ST1 and ST2.

CAUTION:

Be careful not to damage bearing.

ST1 899874100 INSTALLER

ST2 399780104 WEIGHT

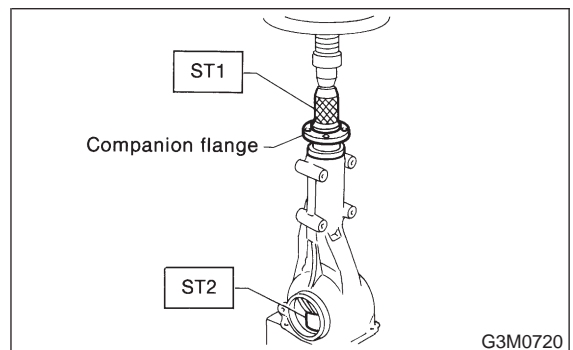

10) Install self-locking nut. Then tighten self-locking nut with ST.

ST 398427700 FLANGE WRENCH

Tightening torque:

188±26 N·m (19.2±2.7 kg·m, 139±20 ft·lb)

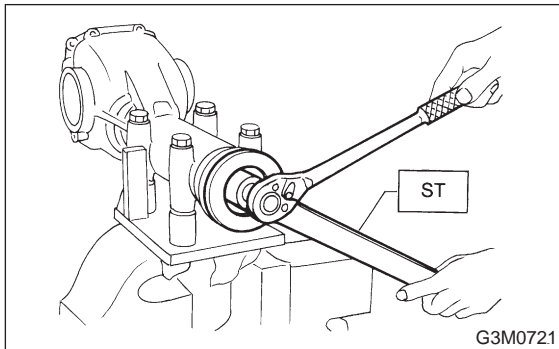

11) Assembling differential case

(1) Install side gears and pinion mate gears, with their thrust washers and pinion mate shaft, into differential case.

NOTE:

- Apply gear oil on both sides of the washer and on the side gear shaft before installing.
- Insert the pinion mate shaft into the differential case by aligning the lock pin holes.

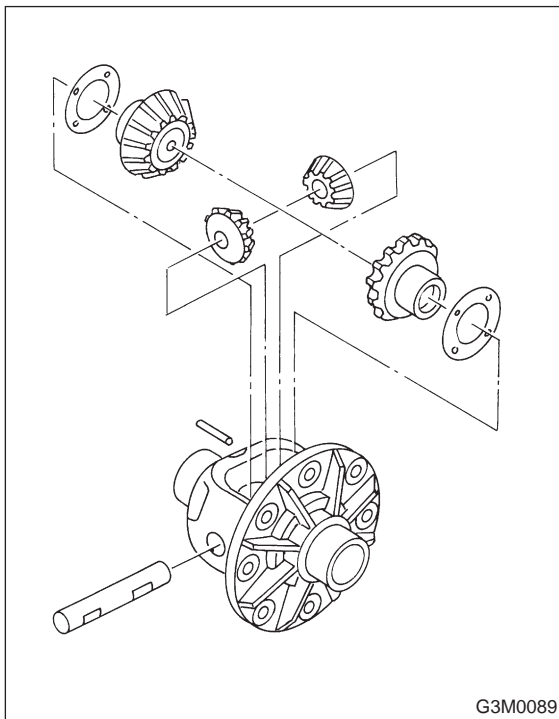

(2) Measure the clearance between differential case and the back of side gear.

(3) Adjust the clearance as specified by selecting side gear thrust washer.

Side gear backlash:

0.05 — 0.15 mm (0.0020 — 0.0059 in)

Side gear thrust washer	
Part No.	Thickness mm (in)
803135011	0.925 — 0.950 (0.0364 — 0.0374)
803135012	0.950 — 0.975 (0.0374 — 0.0384)
803135013	0.975 — 1.000 (0.0384 — 0.0394)
803135014	1.000 — 1.025 (0.0394 — 0.0404)
803135015	1.025 — 1.050 (0.0404 — 0.0413)

(4) Check the condition of rotation after applying oil to the gear tooth surfaces and thrust surfaces.

(5) After driving in pinion shaft lock pin, stake the both sides of the hole to prevent pin from falling off.

(6) Install crown gear on differential case.

NOTE:

Tighten diagonally while tapping the bolt heads.

Tightening torque:

62±5 N·m (6.3±0.5 kg·m, 45.6±3.6 ft·lb)

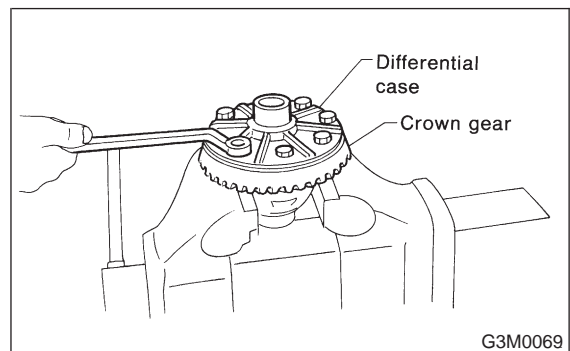

12) Press side bearing cone onto differential case with ST.

ST 498485400 DRIFT

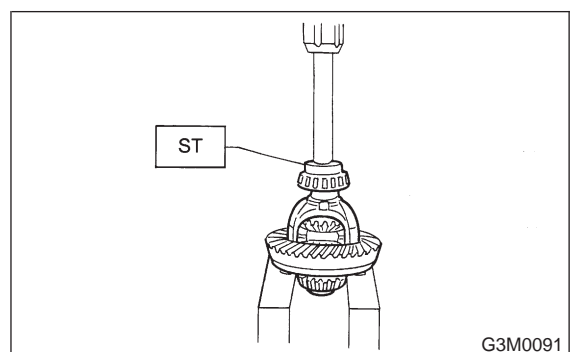

13) Assemble holders.

3-4 [W2E2]
 2. Rear Differential

SERVICE PROCEDURE

(1) Install oil seal into right and left holders.
 ST 498447100 AXLE SHAFT OIL SEAL
 INSTALLER

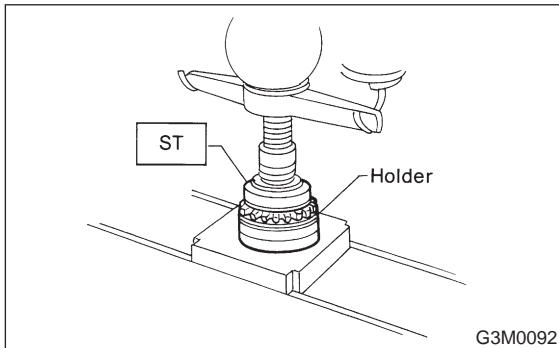

(2) Install bearing race into right and left holders.

ST 398477702 BEARING OUTER RACE
 DRIFT

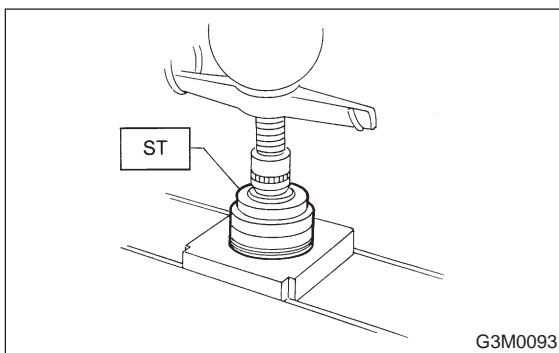

(3) Install the differential case assembly into differential carrier in the reverse order of disassembly.

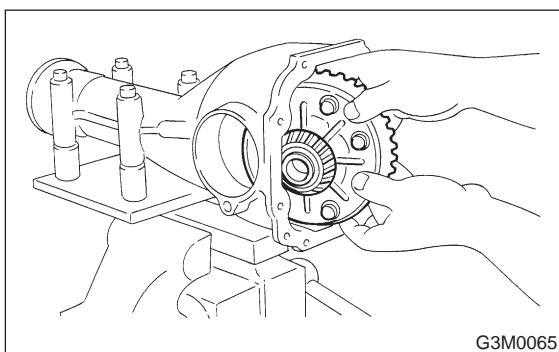

14) Perform adjustment of backlash of pinion crown gear set and adjustment of preload of differential side bearing.

(1) Turn drive pinion with ST for better fitting of differential side bearing.
 ST 498427200 FLANGE WRENCH

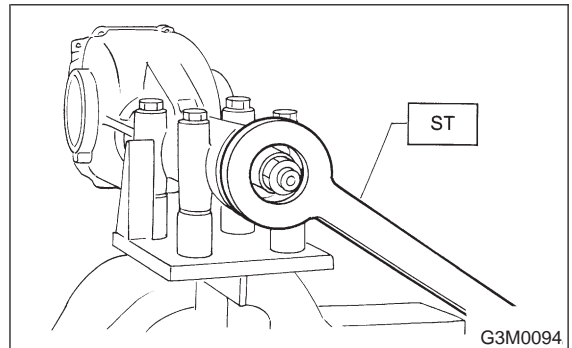

(2) Screw in left-side holder until light contact is made with ST.

ST 399780111 WRENCH

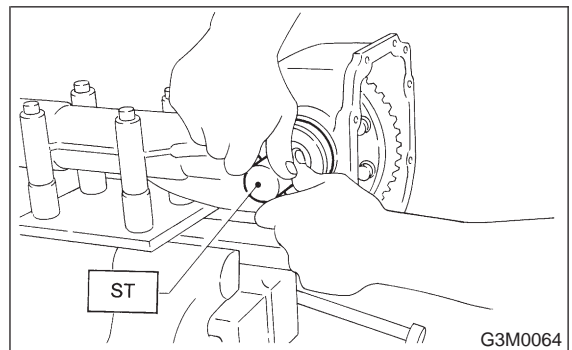

(3) Back off side (left-side) holder approximately 1 1/2 teeth of holder, and tighten left-side holder by approximately 2 teeth (approximately 1 1/2 + 1/2 teeth). [Back off amount of side (left-side) holder + 1/2 tooth].

This + 1/2 tooth gives preload.

(4) Temporarily tighten lock plate.

NOTE:

Turn over lock plate to displace holder 1/2 tooth.

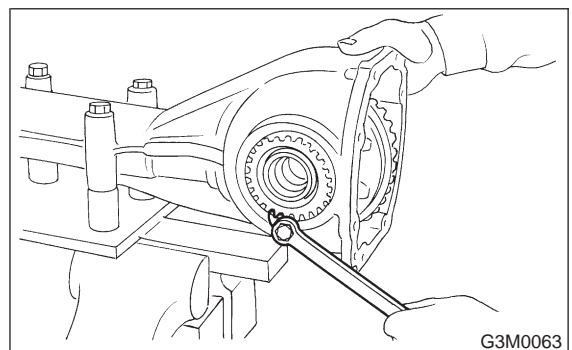

(5) Measure the crown gear-to-drive pinion backlash. Set magnet base on differential carrier. Align contact point of dial gauge with tooth face of crown gear, and move crown gear while holding drive pinion still. Read value indicated on dial gauge.

NOTE:

If measured backlash is not within specified range, repeat procedures for pinion crown gear set backlash adjustment and differential side bearing preload adjustment.

Backlash:

0.10 — 0.15 mm (0.0039 — 0.0059 in)

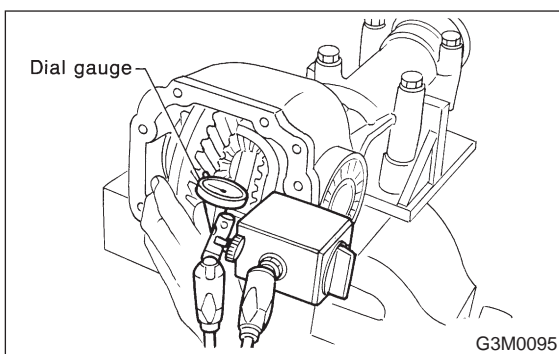

15) Draw a matching mark on both differential carrier and holder. Remove holder one side at a time. Replace in the original position after inserting an O-ring and applying grease to threaded portion.

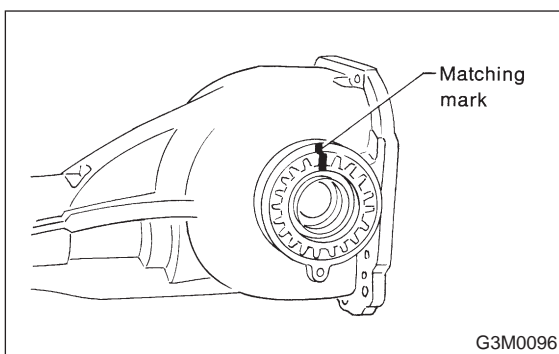

16) Tighten bolt of lock plate to specified torque.

Tightening torque:

25±3 N·m (2.5±0.3 kg·m, 18.1±2.2 ft·lb)

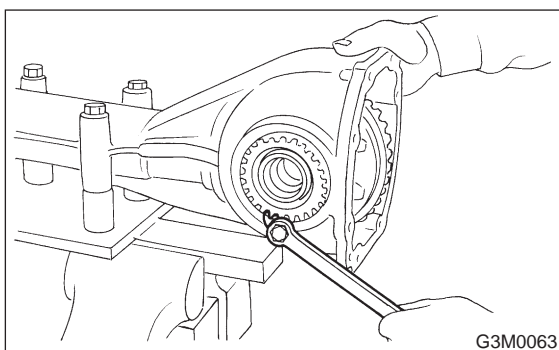

17) Re-check crown gear-to-pinion backlash.

Backlash:

0.10 — 0.15 mm (0.0039 — 0.0059 in)

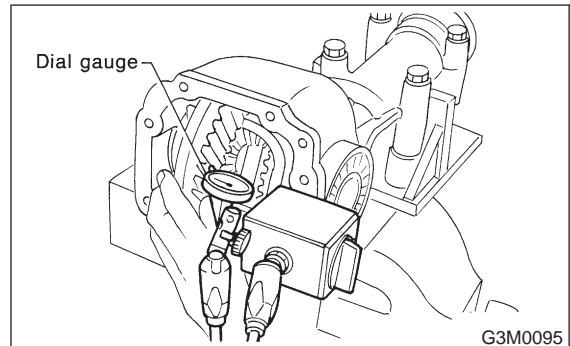

18) Check the crown gear runout on its back surface, and make sure pinion and crown gear rotate smoothly.

Limit of runout:

0.05 mm (0.0020 in)

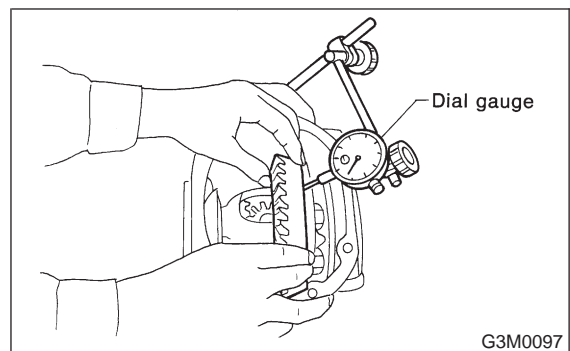

19) Checking and adjusting tooth contact of crown gear.

(1) Apply an even coat of red lead on both sides of three or four teeth on the crown gear. Check the contact pattern after rotating crown gear several revolutions back and forth until a definite contact pattern appears on the crown gear.

(2) When the contact pattern is incorrect, readjust according to the instructions given in "Tooth contact pattern".

NOTE:

Be sure to wipe off red lead completely after adjustment is completed.

20) If proper tooth contact is not obtained, once again adjust the drive pinion height and the differential side bearing preload (mentioned above) and the hypoid gear backlash.

3-4 [W2E2]

2. Rear Differential

SERVICE PROCEDURE

(1) Drive pinion height

ST1 498447150 DUMMY SHAFT
ST2 498505501 DIFFERENTIAL CARRIER GAUGE

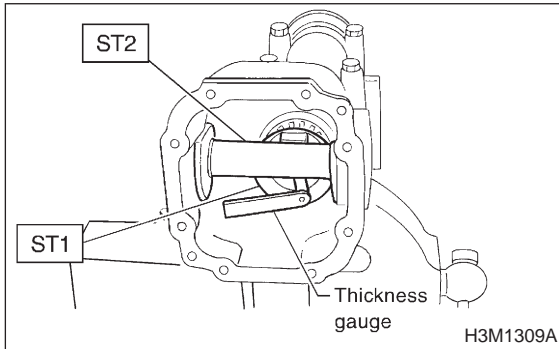

$$T = T_o + N - 0.05 \text{ (mm)}$$

where

T = Thickness of pinion height adjusting shim (mm)

T_o = Thickness of shim originally inserted (mm)

N = Reading of thickness gauge (mm)

(2) Differential side bearing preload

Back off side (left-side) holder approximately 1 1/2 teeth of holder, and tighten left-side holder by approximately 2 teeth (approximately 1 1/2 + 1/2 teeth). [Back off amount of side (left-side) holder + 1/2 tooth].

This + 1/2 tooth gives preload.

ST 399780111 WRENCH

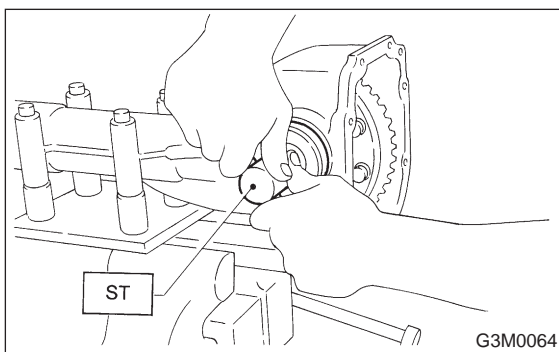

(3) Hypoid gear backlash

Backlash:

0.10 — 0.15 mm (0.0039 — 0.0059 in)

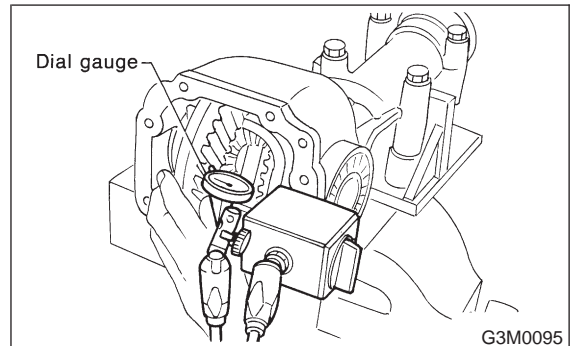

- ➔ Adjusting direction of drive pinion
- ⇨ Adjusting direction of crown gear

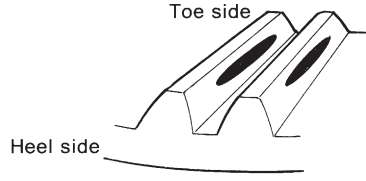
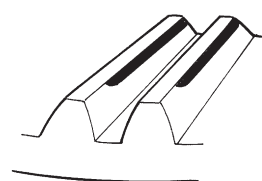
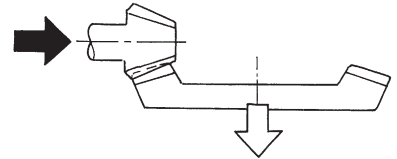
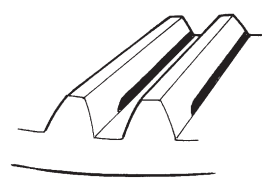
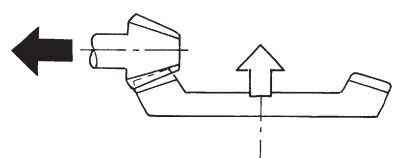
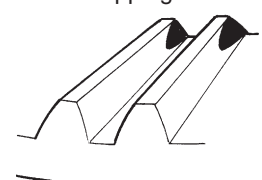
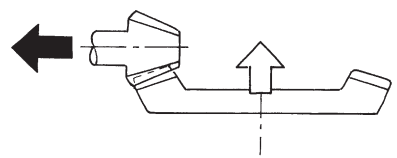
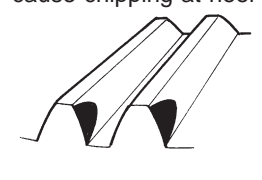
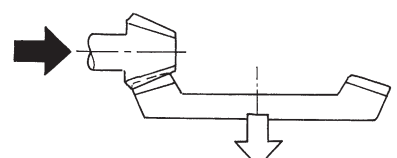
TOOTH CONTACT PATTERN		
Condition	Contact pattern	Adjustment
<p>Correct tooth contact Tooth contact pattern slightly shifted towards toe under no load rotation. (When loaded, contact pattern moves toward heel.)</p>	<p>Toe side</p>  <p>Heel side</p> <p>G3M0098A</p>	<p>—</p>
<p>Face contact Backlash is too large.</p>	<p>This may cause noise and chipping at tooth ends.</p>  <p>G3M0098B</p>	<p>Increase thickness of drive pinion height adjusting washer in order to bring drive pinion closer to crown gear center.</p>  <p>G3M0098F</p>
<p>Flank contact Backlash is too small.</p>	<p>This may cause noise and stepped wear on surfaces.</p>  <p>G3M0098C</p>	<p>Reduce thickness of drive pinion height adjusting washer in order to move drive pinion away from crown gear.</p>  <p>G3M0098G</p>
<p>Toe contact</p>	<p>Contact area is small. This may cause chipping at toe ends.</p>  <p>G3M0098D</p>	<p>Adjust as for flank contact.</p>  <p>G3M0098G</p>
<p>Heel contact</p>	<p>Contact area is small. This may cause chipping at heel ends.</p>  <p>G3M0098E</p>	<p>Adjust as for face contact</p>  <p>G3M0098F</p>

F: INSTALLATION

To install, reverse the removal sequence.

- 1) Install the air breather cap tapping with a plastic hammer.

CAUTION:

Be sure to install new air breather cap.

- 2) Position front member on body by passing it under parking brake cable and securing to rear differential.

3-4 [W3A1]

3. Rear Differential Front Member

SERVICE PROCEDURE

NOTE:

When installing rear differential front member, do not confuse the installation sequence of the upper and lower stoppers.

3) Install DOJ of rear drive shaft into rear differential.

ST 28099PA090 SIDE OIL SEAL PROTECTOR

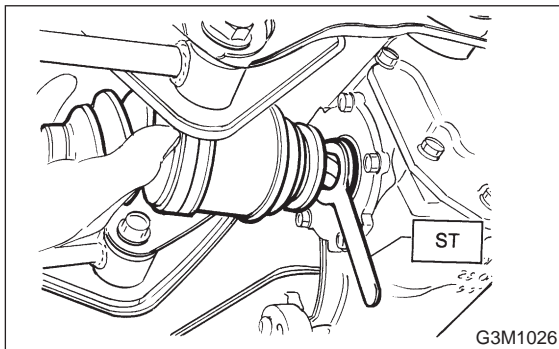

4) Installing procedure hereafter is in the reverse order of removal.

5) After installation, fill differential carrier with gear oil to the upper plug level.

CAUTION:

- Apply fluid packing to plug (T-type).
- Use a new aluminum gasket when installing the plug (VA-type).

Fluid packing:

THREE BOND 1105 or equivalent

Oil capacity:

0.8 l (0.8 US qt, 0.7 Imp qt)

Tightening torque:

T-type;

44±4 N·m (4.5±0.4 kg·m, 32.5±2.9 ft·lb)

VA-type;

34±4 N·m (3.5±0.4 kg·m, 25.3±2.9 ft·lb)

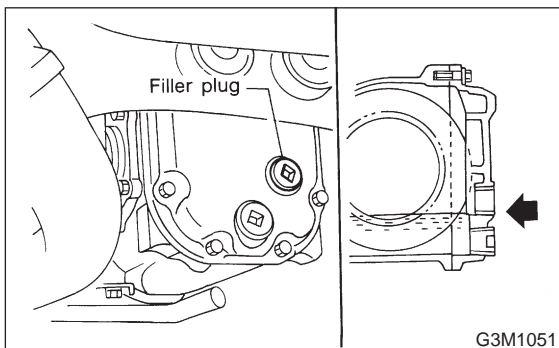

3. Rear Differential Front Member

A: REMOVAL

1. T-TYPE

- 1) Disconnect ground cable from battery.
- 2) Move selector lever or gear shift lever to "N".
- 3) Release the parking brake.
- 4) Loosen wheel nuts.
- 5) Jack-up vehicle and support it with sturdy racks.
- 6) Remove wheels.
- 7) Remove rear exhaust pipe.
<Ref. to 2-9 [W2A0].>
- 8) Remove muffler.
<Ref. to 2-9 [W3A0].>
- 9) Remove rear differential front member.

NOTE:

When removing rear differential front member, work the removal procedure as rear differential.

<Ref. to 3-4 [W2B1].>

2. VA-TYPE

- 1) Disconnect ground cable from battery.
- 2) Move selector lever or gear shift lever to "N".
- 3) Release the parking brake.
- 4) Loosen wheel nuts.
- 5) Jack-up vehicle and support it with sturdy racks.
- 6) Remove wheels.
- 7) Remove rear exhaust pipe.
<Ref. to 2-9 [W2A0].>
- 8) Remove muffler.
<Ref. to 2-9 [W3A0].>
- 9) Remove rear differential front member.

NOTE:

When removing rear differential front member, work the removal procedure as rear differential.

<Ref. to 3-4 [W2B2].>

B: INSTALLATION

1. T-TYPE

To install, reverse the removal sequence.

3-4 [W3A1]

3. Rear Differential Front Member

SERVICE PROCEDURE

NOTE:

When installing rear differential front member, do not confuse the installation sequence of the upper and lower stoppers.

3) Install DOJ of rear drive shaft into rear differential.

ST 28099PA090 SIDE OIL SEAL PROTECTOR

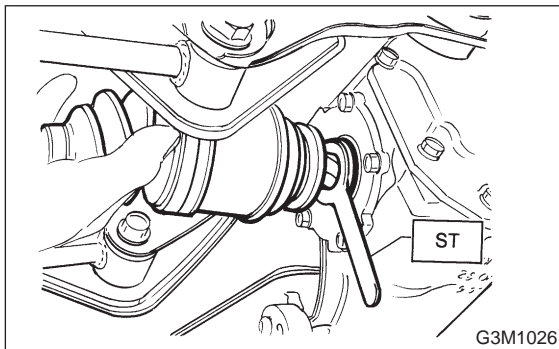

4) Installing procedure hereafter is in the reverse order of removal.

5) After installation, fill differential carrier with gear oil to the upper plug level.

CAUTION:

- Apply fluid packing to plug (T-type).
- Use a new aluminum gasket when installing the plug (VA-type).

Fluid packing:

THREE BOND 1105 or equivalent

Oil capacity:

0.8 l (0.8 US qt, 0.7 Imp qt)

Tightening torque:

T-type;

44±4 N·m (4.5±0.4 kg·m, 32.5±2.9 ft·lb)

VA-type;

34±4 N·m (3.5±0.4 kg·m, 25.3±2.9 ft·lb)

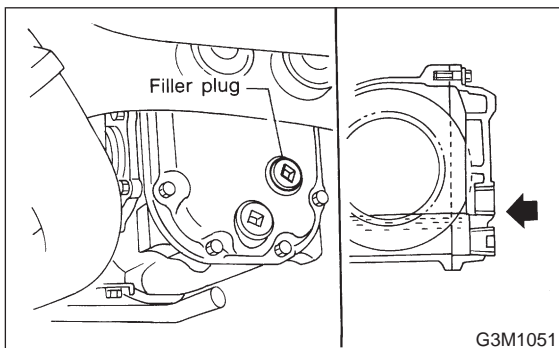

3. Rear Differential Front Member

A: REMOVAL

1. T-TYPE

- 1) Disconnect ground cable from battery.
- 2) Move selector lever or gear shift lever to "N".
- 3) Release the parking brake.
- 4) Loosen wheel nuts.
- 5) Jack-up vehicle and support it with sturdy racks.
- 6) Remove wheels.
- 7) Remove rear exhaust pipe.
<Ref. to 2-9 [W2A0].>
- 8) Remove muffler.
<Ref. to 2-9 [W3A0].>
- 9) Remove rear differential front member.

NOTE:

When removing rear differential front member, work the removal procedure as rear differential.

<Ref. to 3-4 [W2B1].>

2. VA-TYPE

- 1) Disconnect ground cable from battery.
- 2) Move selector lever or gear shift lever to "N".
- 3) Release the parking brake.
- 4) Loosen wheel nuts.
- 5) Jack-up vehicle and support it with sturdy racks.
- 6) Remove wheels.
- 7) Remove rear exhaust pipe.
<Ref. to 2-9 [W2A0].>
- 8) Remove muffler.
<Ref. to 2-9 [W3A0].>
- 9) Remove rear differential front member.

NOTE:

When removing rear differential front member, work the removal procedure as rear differential.

<Ref. to 3-4 [W2B2].>

B: INSTALLATION

1. T-TYPE

To install, reverse the removal sequence.

1) Position front member on body by passing it under parking brake cable and securing to rear differential.

NOTE:

When installing rear differential front member, do not confuse the installation sequence of the stopper.

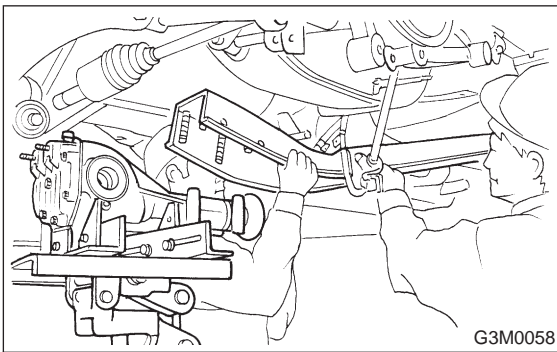

2) Insert DOJ of rear drive shaft into rear differential.

<Ref. to 3-4 [W2C1].>

CAUTION:

Before inserting, replace the differential side oil seal with a new one.

ST 28099PA090 SIDE OIL SEAL PROTECTOR

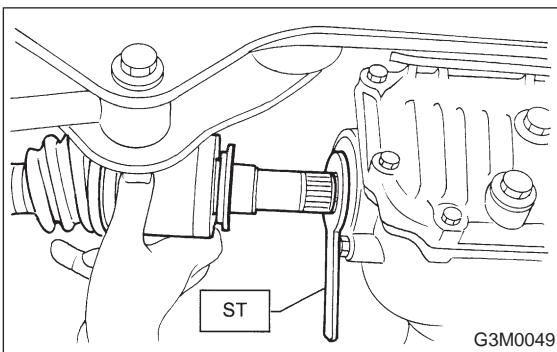

3) Installing procedure hereafter is in the reverse order of removal.

2. VA-TYPE

To install, reverse the removal sequence.

1) Position front member on body by passing it under parking brake cable and securing to rear differential.

NOTE:

When installing rear differential front member, do not confuse the installation sequence of the stopper.

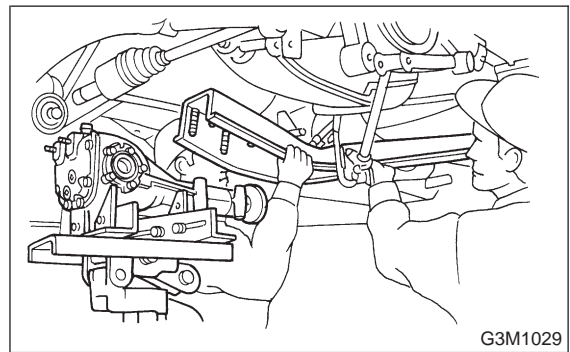

2) Insert DOJ of rear drive shaft into rear differential.

<Ref. to 3-4 [W2C2].>

CAUTION:

Before inserting, replace the differential side oil seal with a new one.

ST 28099PA090 SIDE OIL SEAL PROTECTOR

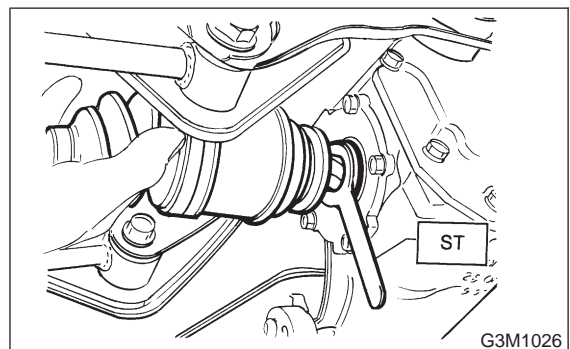

3) Installing procedure hereafter is in the reverse order of removal.

MEMO:

1. Propeller Shaft

NOTE:

Vibration while cruising may be caused by an unbalanced tire, improper tire inflation pressure, improper wheel alignment, etc.

Symptom	Possible cause	Remedy
1. Vibration of propeller shaft NOTE: Vibration is caused by propeller shaft during operation and is transferred to vehicle body. Generally vibration increases in proportion to vehicle speed.	(1) Worn or damaged universal joint.	Replace.
	(2) Unbalanced propeller shaft due to bend or dent.	Replace.
	(3) Loose installation of propeller shaft.	Retighten.
	(4) Worn or damaged center bearing and damaged center mounting rubber.	Replace.
2. Tapping when starting and noise while cruising, caused by propeller shaft.	(1) Worn or damaged universal joint.	Replace.
	(2) Worn spline of sleeve yoke.	Replace.
	(3) Loose installation of propeller shaft.	Retighten.
	(4) Loose installation of joint.	Replace.
	(5) Worn or damaged center bearing and damaged center mounting rubber.	Replace.

2. Rear Differential

Symptom	Possible cause	Remedy
1. Oil leakage	(1) Worn, scratched, or incorrectly seated front or side oil seal. Scored, battered, or excessively worn sliding surface of companion flange.	Repair or replace.
	(2) Clogged or damaged air breather.	Clean, repair or replace.
	(3) Loose bolts on differential spindle or side retainer, or incorrectly fitted O-ring.	Tighten bolts to specified torque. Replace O-ring.
	(4) Loose rear cover attaching bolts or damaged gasket.	Tighten bolts to specified torque. Replace gasket and apply liquid packing.
	(5) Loose oil filler or drain plug.	Retighten and apply liquid packing.
	(6) Wear, damage or incorrectly fitting for spindle, side retainer and oil seal.	Repair or replace.
2. Seizure NOTE: Seized or damaged parts should be replaced, and also other parts should be thoroughly checked for any defect and should be repaired or replaced as required.	(1) Insufficient backlash for hypoid gear.	Readjust or replace.
	(2) Excessive preload for side, rear, or front bearing.	Readjust or replace.
	(3) Insufficient or improper oil used.	Replace seized part and fill with specified oil to specified level.
3. Damage NOTE: Damaged parts should be replaced, and also other parts should be thoroughly checked for any defect and should be repaired or replaced as required.	(1) Improper backlash for hypoid gear.	Replace.
	(2) Insufficient or excessive preload for side, rear, or front bearing.	Readjust or replace.
	(3) Excessive backlash for differential gear.	Replace gear or thrust washer.
	(4) Loose bolts and nuts such as crown gear bolt.	Retighten.
	(5) Damage due to overloading.	Replace.
4. Noises when starting or shifting gears NOTE: Noises may be caused by differential assembly, universal joint, wheel bearing, etc. Find out what is actually making noise before disassembly.	(1) Excessive backlash for hypoid gear.	Readjust.
	(2) Excessive backlash for differential gear.	Replace gear or thrust washer.
	(3) Insufficient preload for front or rear bearing.	Readjust.
	(4) Loose drive pinion nut.	Tighten to specified torque.
	(5) Loose bolts and nuts such as side bearing retainer attaching bolt.	Tighten to specified torque.
5. Noises when cornering	(1) Damaged differential gear.	Replace.
	(2) Excessive wear or damage of thrust washer.	Replace.
	(3) Broken pinion mate shaft.	Replace.
	(4) Seized or damaged side bearing.	Replace.
6. Gear noises NOTE: Since noises from engine, muffler, transmission, propeller shaft, wheel bearings, tires, and body are sometimes mistaken for noises from differential assembly, be careful in checking them. Inspection methods to locate noises include coasting, accelerating, cruising, and jacking-up all four wheels. Perform these inspections according to condition of trouble. When listening to noises, shift gears into four wheel drive and fourth speed position, trying to pick up only differential noise.	(1) Improper tooth contact of hypoid gear.	Readjust or replace hypoid gear set.
	(2) Improper backlash for hypoid gear.	Readjust.
	(3) Scored or chipped teeth of hypoid gear.	Replace hypoid gear set.
	(4) Seized hypoid gear.	Replace hypoid gear set.
	(5) Improper preload for front or rear bearings.	Readjust.
	(6) Seized, scored, or chipped front or rear bearing.	Replace.
	(7) Seized, scored, or chipped side bearing.	Replace.
	(8) Vibrating differential carrier.	Replace.