

8. Front Fender

A: REMOVAL AND INSTALLATION

- 1) Disconnect ground cable from battery.
- 2) Remove mud guard. <Ref. to 5-1 [W9A0].>
- 3) Remove headlight. <Ref. to 6-2 [W4B2].>
- 4) Remove front bumper face. <Ref. to 5-1 [W3A0].>
- 5) Remove side sill protector. <Ref. to 5-1 [W7A2].>
- 6) Remove attaching bolt then remove fender.

CAUTION:

Be careful not to scratch body panels with fender edges when removing it.

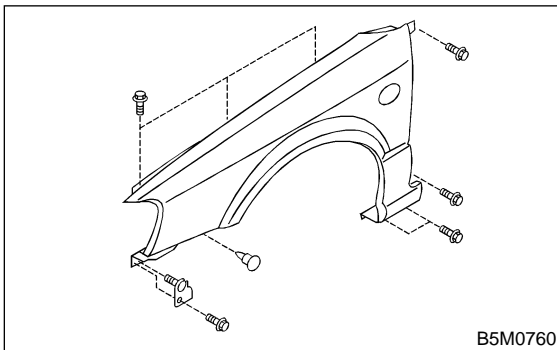

- 7) Installation is in the reverse order of removal.

NOTE:

Check for alignment of front fender with hood and front door with front fender at all points. Adjust, if necessary.

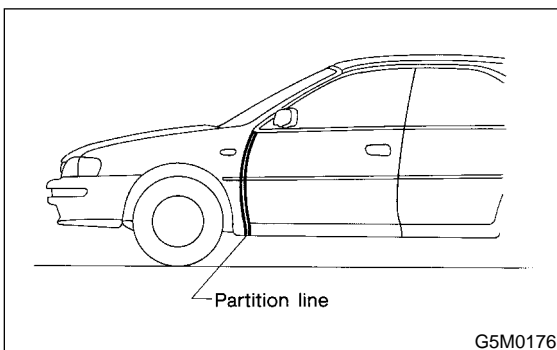
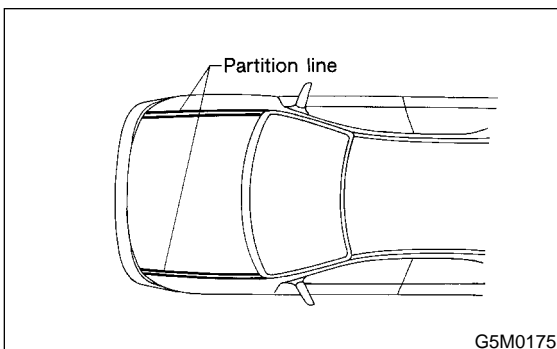

9. Mud Guard

A: REMOVAL AND INSTALLATION

- 1) Jack-up vehicle and remove tire.
- 2) Remove screws and clips. Move mud guard toward the center of the body and remove mud guard.

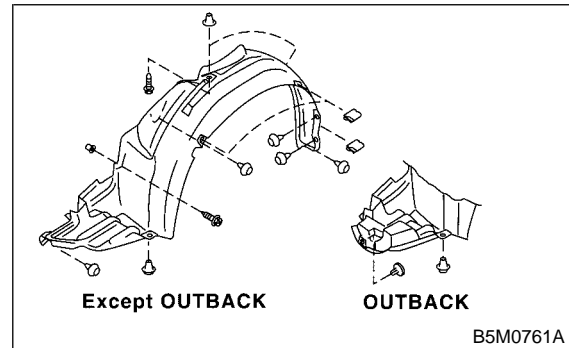

- 3) Installation is in the reverse order of removal.

CAUTION:

Only use new nuts and clips.