

3. Tools for Diagnostics

CAUTION:

Be sure to use specified test harness A, F, G, H and I or I2 when measuring voltage, resistance, etc. of AIRBAG system component parts.

A: TEST HARNESS A

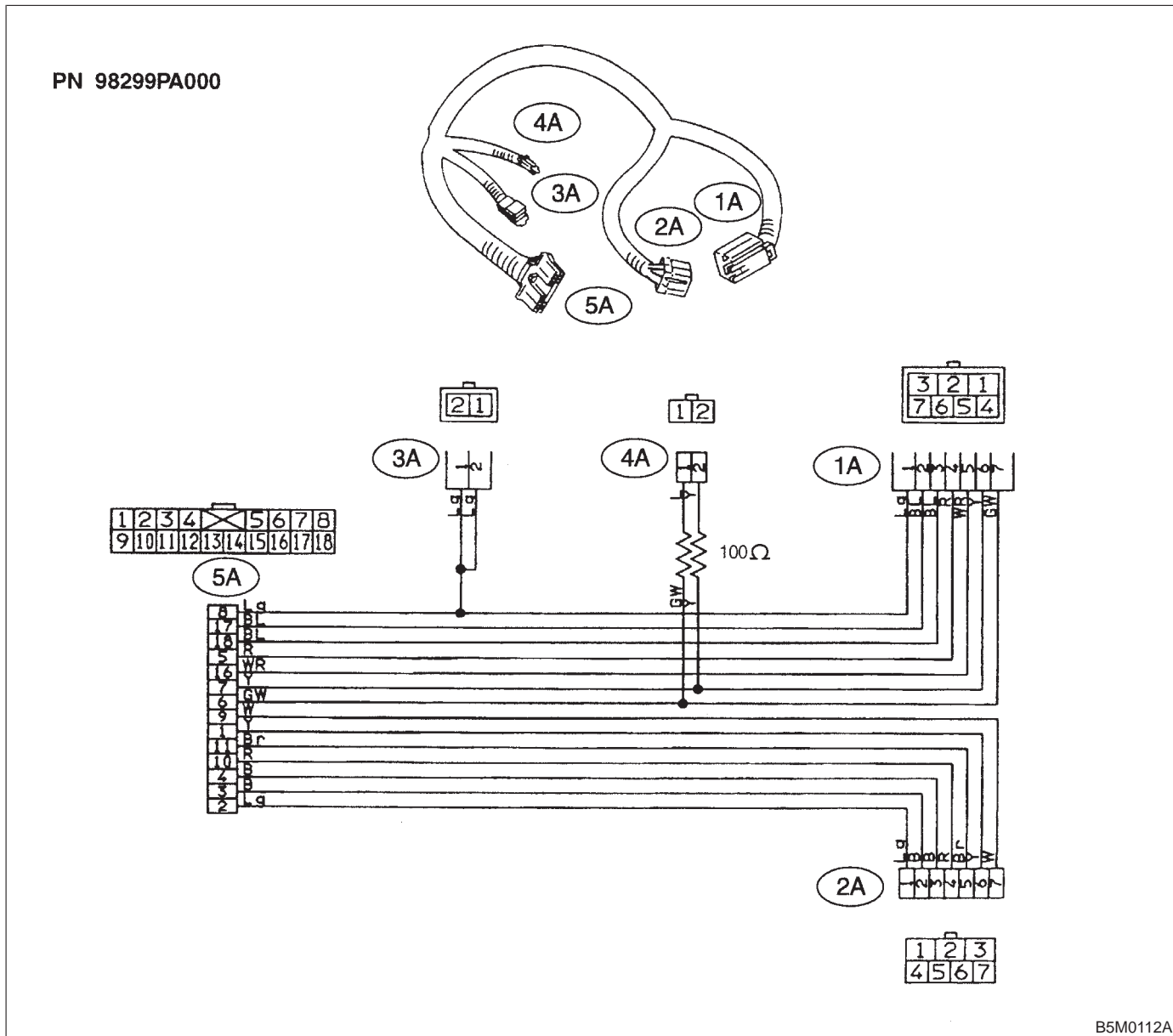

B5M0112A

B: TEST HARNESS F

PN 98299FC010

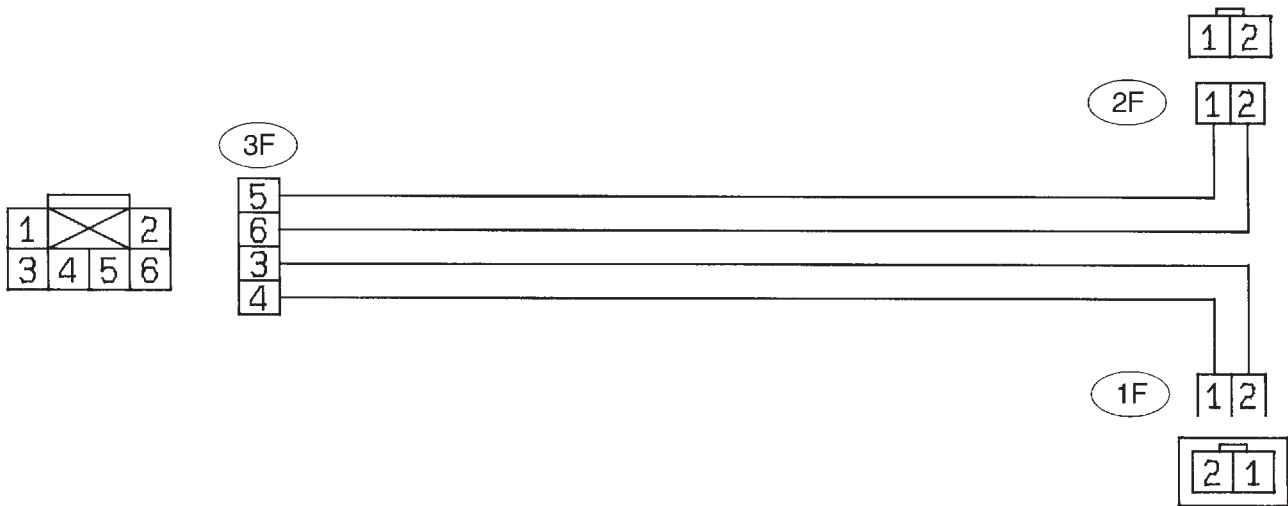
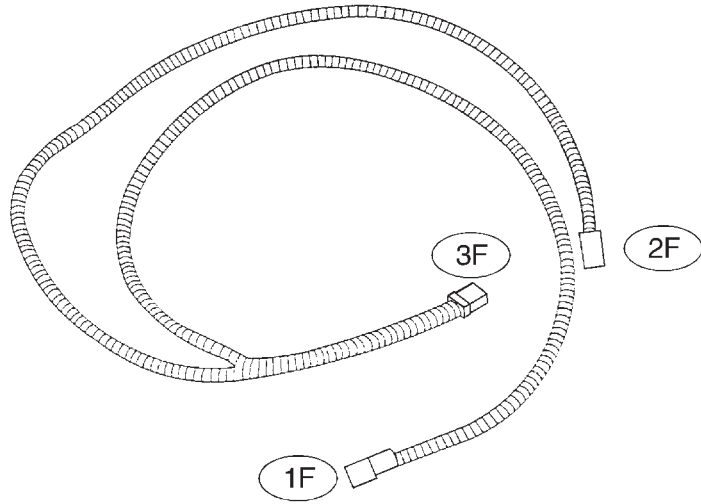

S5M0247A

C: TEST HARNESS G

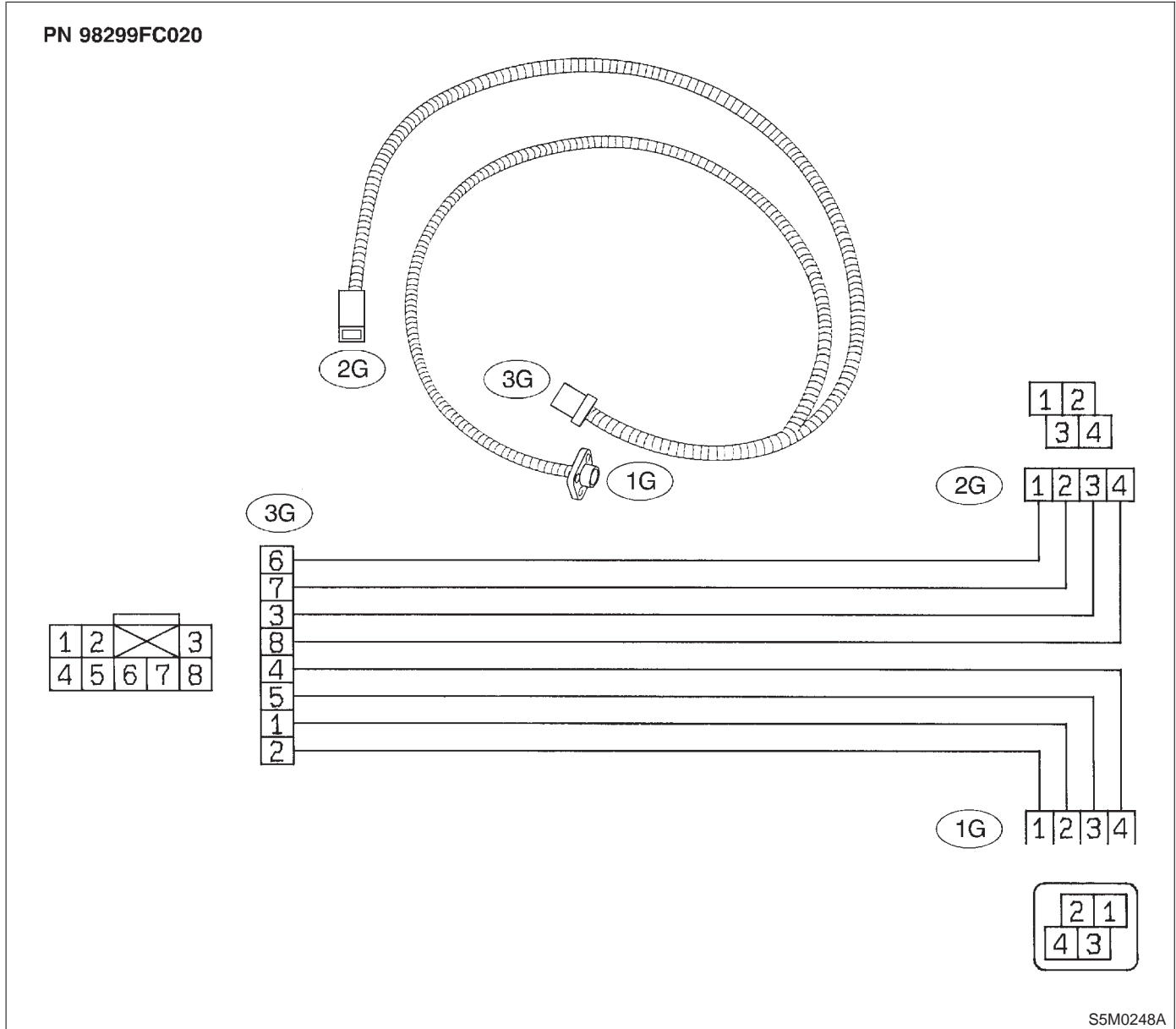

S5M0248A

D: TEST HARNESS H

PN 98299FA030

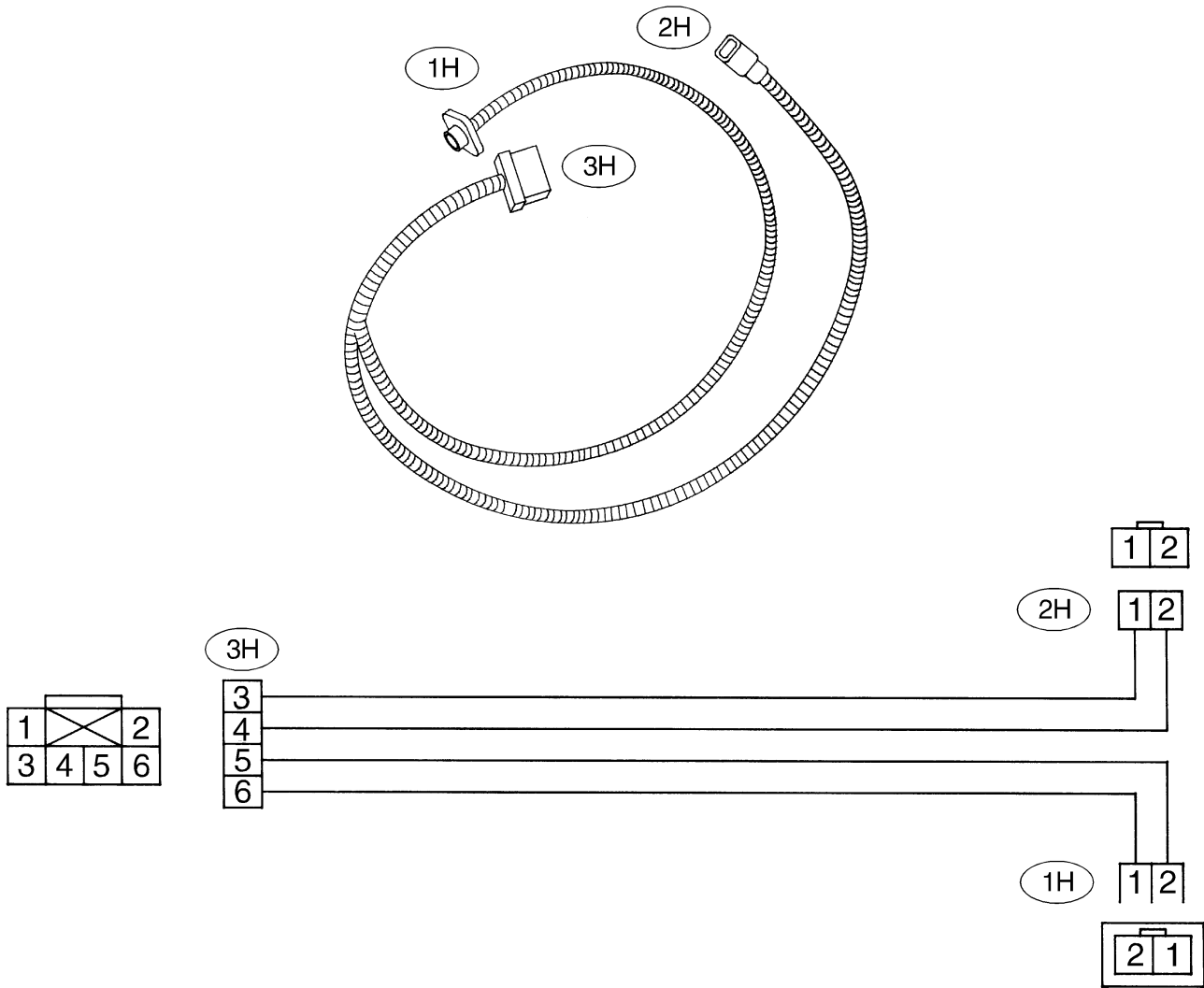

B5M0553B

E: TEST HARNESS I

PN 98299FC040

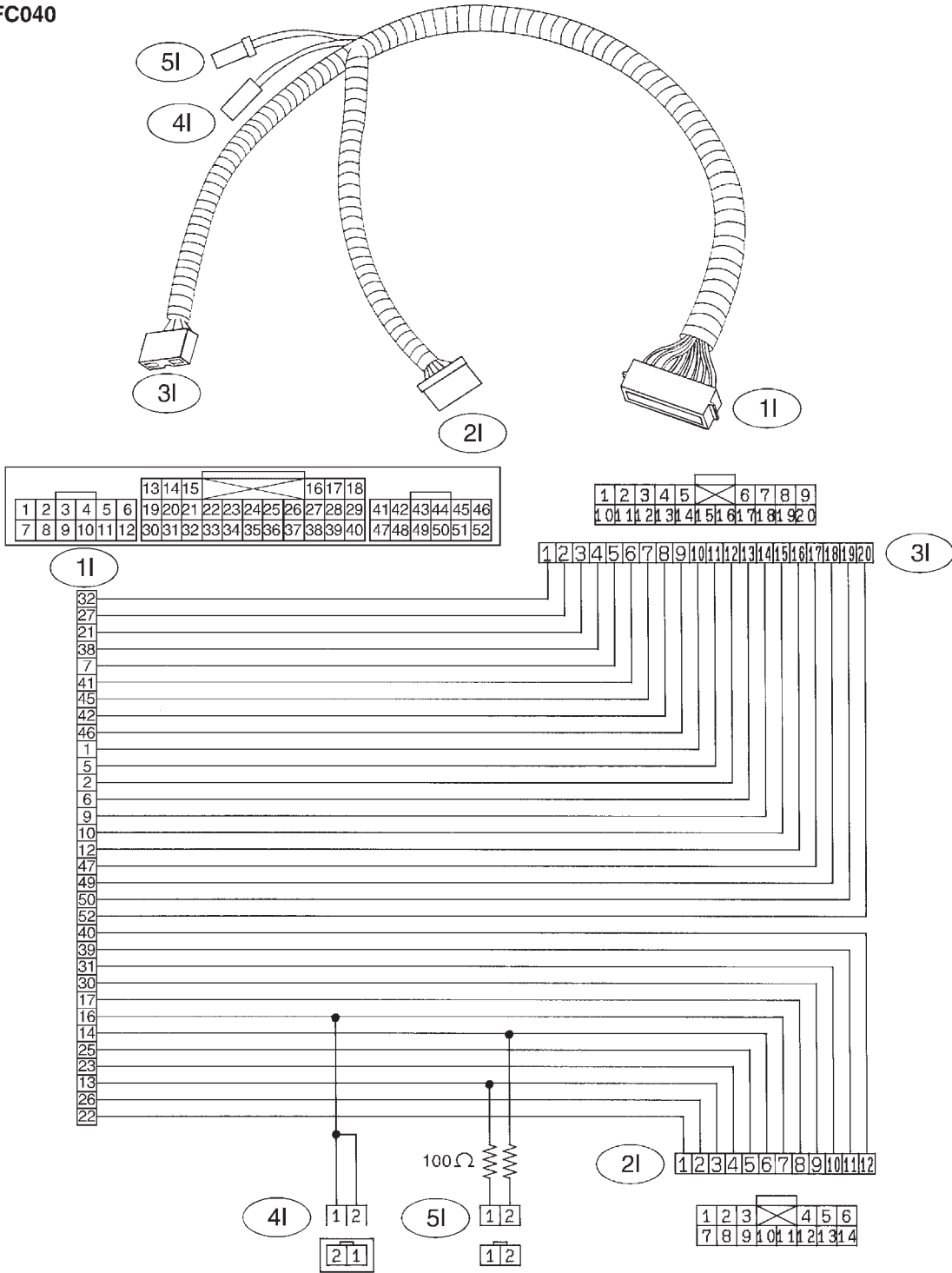

S5M0340A

F: TEST HARNESS I2

PN 98299FC041

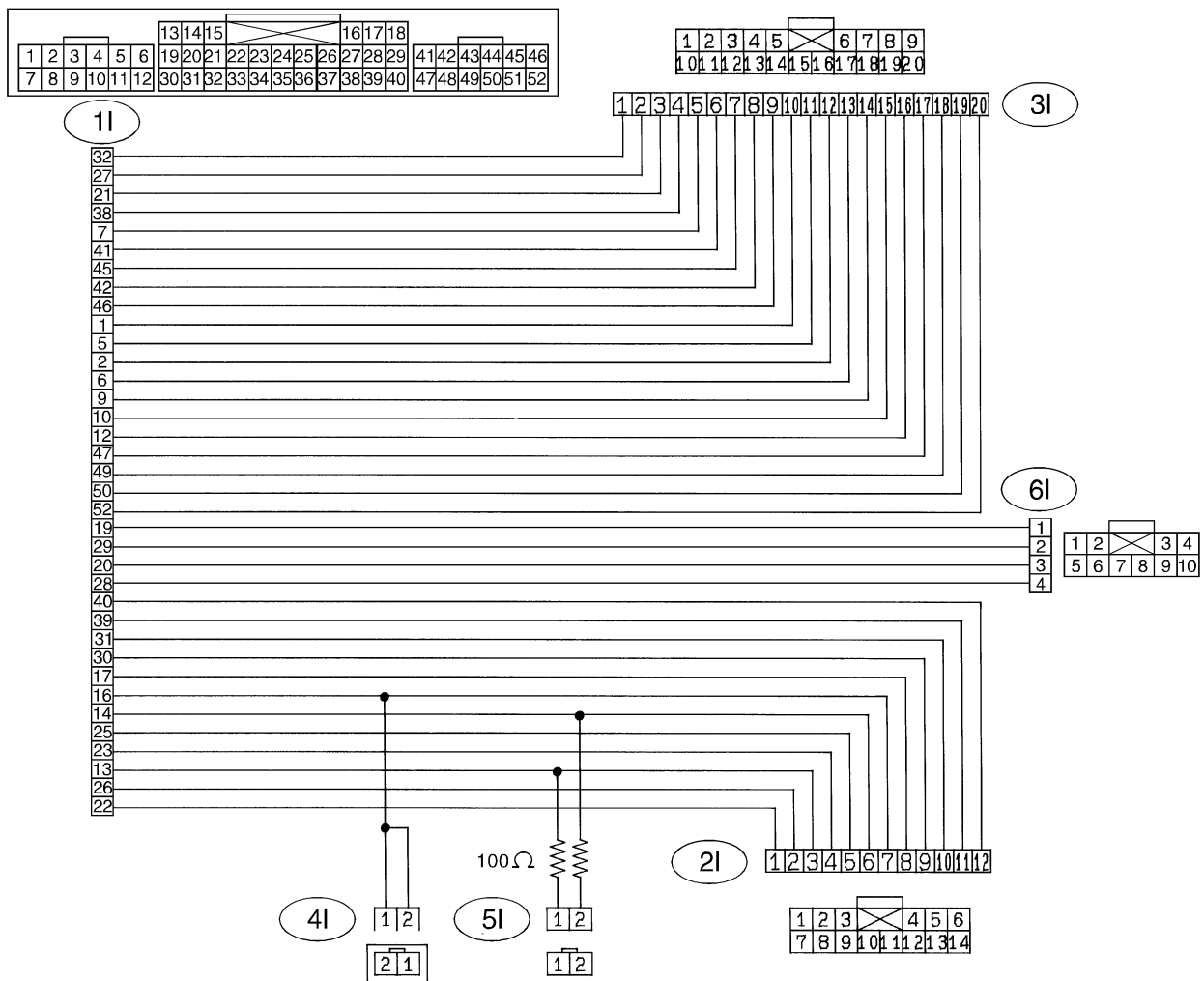
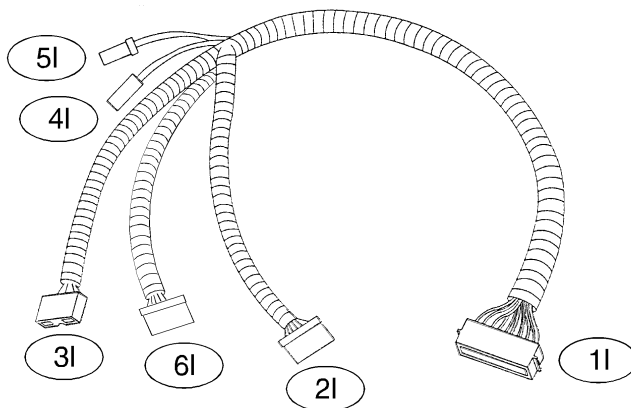

B5M0927A

G: AIRBAG RESISTOR

The airbag resistor is used during diagnostics. The airbag resistor has the same resistance as the airbag module and thus provides safety when used instead of the airbag module. It also makes it possible to finish diagnostics in less time.

