

3. Release Bearing and Lever

5) Tighten air bleeder.

Tightening torque:

T: 8 ± 2 N·m (0.8 ± 0.2 kg·m, 5.8 ± 1.4 ft·lb)

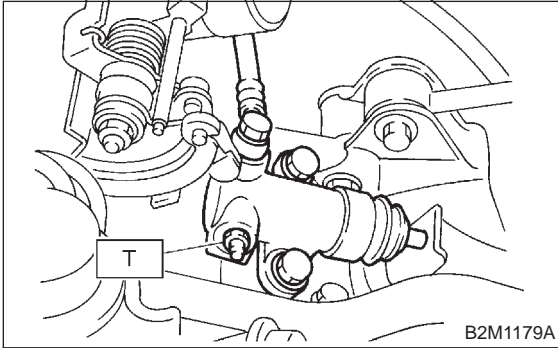

- 6) After depressing the clutch pedal, make sure that there are no leaks evident in the entire system.
 7) After bleeding air from system, ensure that clutch operates properly.

3. Release Bearing and Lever**A: REMOVAL**

1) Remove transmission assembly from vehicle body.

<Ref. to 2-11 [W2A0].>

2) Remove the two clips from clutch release lever and remove release bearing.

CAUTION:

Be careful not to deform clips.

3) Remove release lever seal.

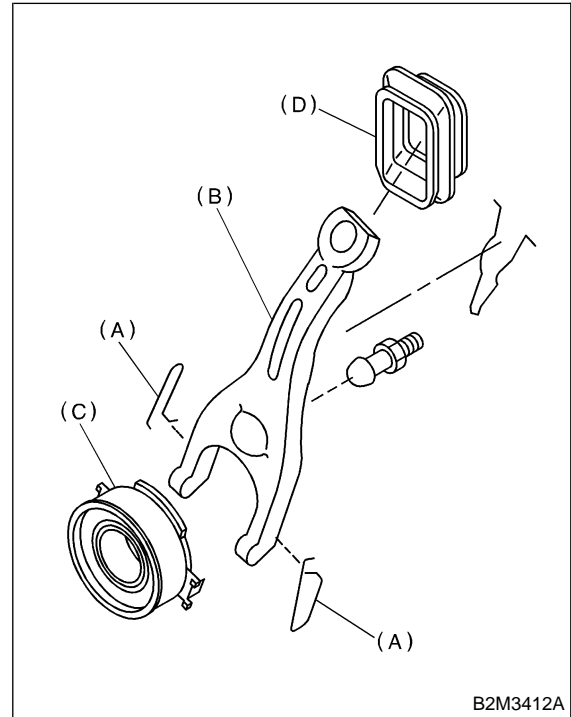

- (A) Clip
 (B) Clutch release lever
 (C) Release bearing
 (D) Release lever seal

4) Remove release lever retainer spring from release lever pivot with a screwdriver by accessing it through clutch housing release lever hole. Then remove release lever.

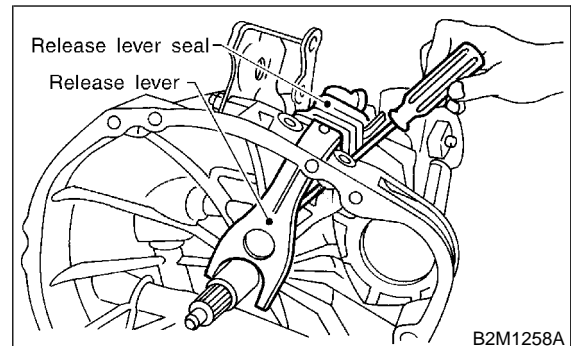

B: INSPECTION

1. RELEASE BEARING

CAUTION:

Since this bearing is grease sealed and is of a non-lubrication type, do not wash with gasoline or any solvent when servicing the clutch.

1) Check the bearing for smooth movement by applying force in the radial direction.

Radial direction stroke:
1.4 mm (0.055 in)

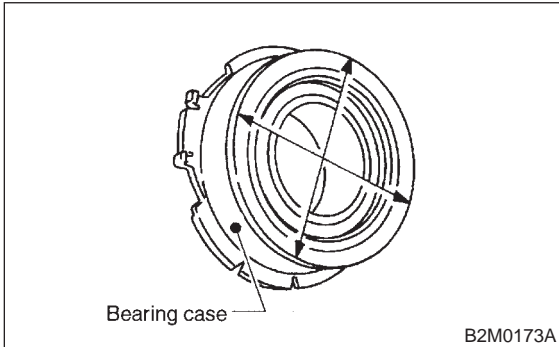

2) Check the bearing for smooth rotation by applying pressure in the thrust direction.

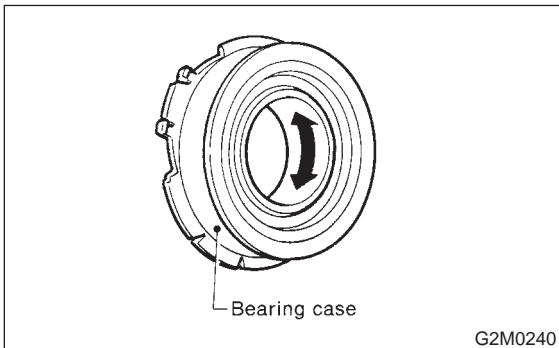

3) Check wear and damage of bearing case surface contacting with lever.

2. RELEASE LEVER

1) Check lever pivot portion and the point of contact with release bearing case for wear.

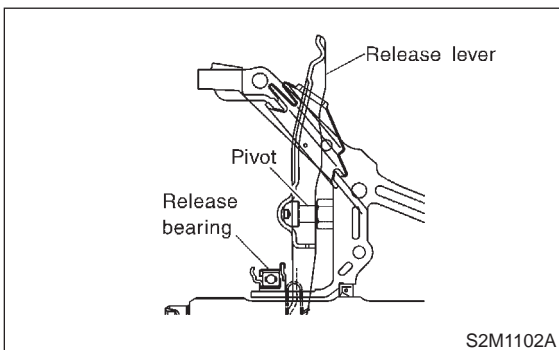

C: INSTALLATION

CAUTION:

Before or during assembling, lubricate the following points with a light coat of grease.

- Contact surface of lever and pivot
- Contact surface of lever and bearing
- Transmission main shaft spline (Use grease containing molybdenum disulphide.)
- Contact surface of lever and operating cylinder

1) While pushing release lever to pivot and twisting it to both sides, fit retainer spring onto the constricted portion of pivot.

NOTE:

- Apply grease (SUNLIGHT 2: P/N 003602010) to contact point of release lever and operating cylinder.
- Confirm that retainer spring is securely fitted by observing it through the main case hole.

2) Install release bearing and fasten it with two clips.

3) Install release lever seal.

Tightening torque:

T: 37±3 N·m (3.8±0.3 kg·m, 27.5±2.2 ft·lb)

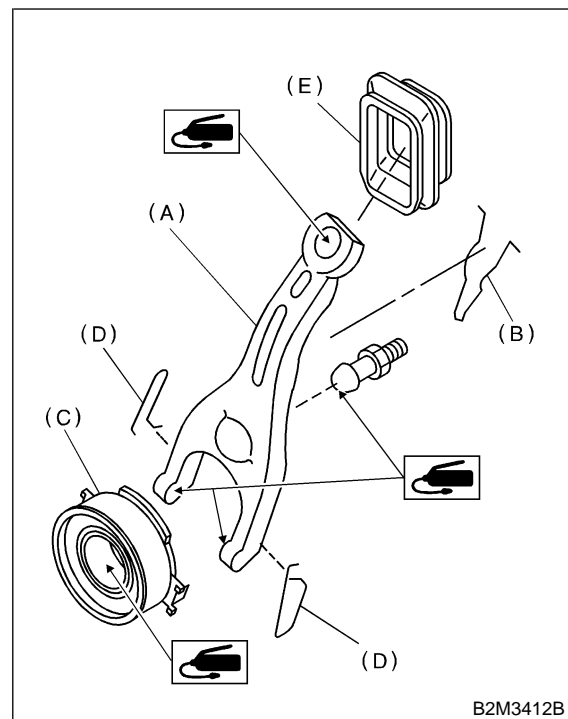

- (A) Release lever
- (B) Retainer spring
- (C) Release bearing
- (D) Clip
- (E) Release lever seal