

E: INSTALLATION

Installation is in the reverse order of removal.

Do the following:

- 1) Apply fluid packing to matching surfaces of oil pump.

Fluid packing:

THREE BOND 1215 or equivalent

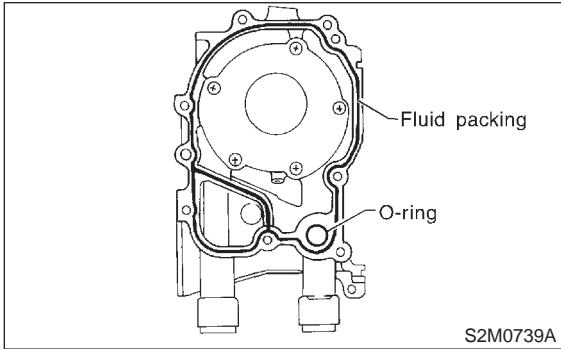

- 2) Replace O-ring with a new one.
- 3) Apply a coat of engine oil to the inside of the oil seal.

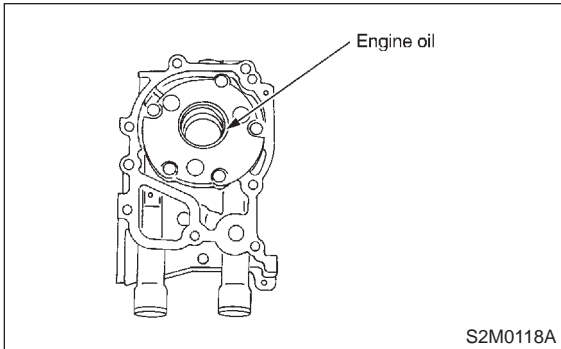

- 4) Be careful not to scratch oil seal when installing oil pump on cylinder block.
- 5) Position the oil pump, aligning the notched area with the crankshaft, and push the oil pump straight.

CAUTION:

Make sure the oil seal lip is not folded.

- 6) Install oil pump.

Tightening torque:

6.4 N-m (0.65 kg-m, 4.7 ft-lb)

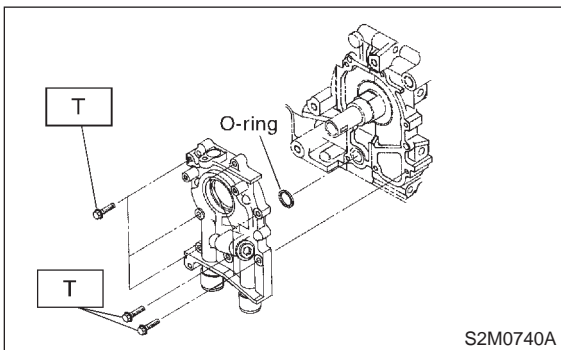
**2. Oil Pan and Oil Strainer****A: REMOVAL**

- 1) Set the vehicle on lift arms.
- 2) Remove front wheels.
- 3) Disconnect battery ground cable.

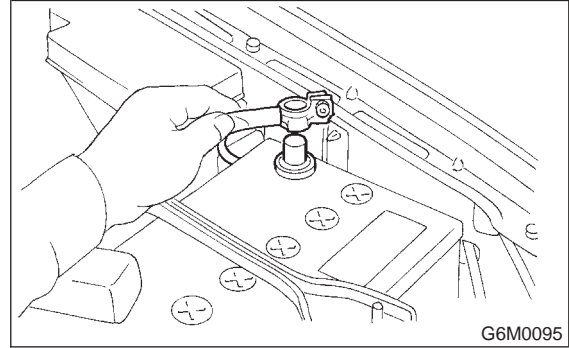

- 4) Remove air intake duct and air cleaner case. <Ref. to 2-7 [W1A0].>

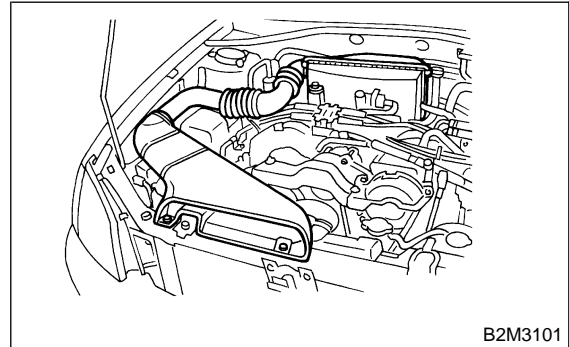

- 5) Disconnect connector from front oxygen (A/F) sensor.

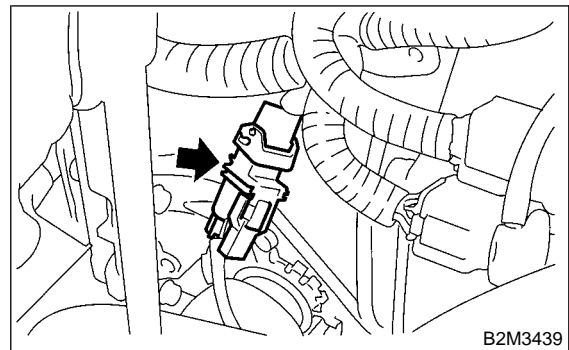

6) Remove pitching stopper.

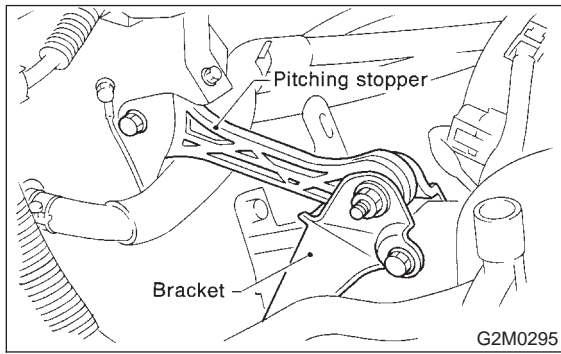

7) Remove radiator upper brackets.

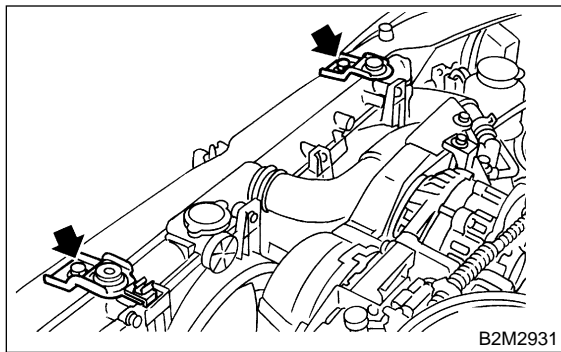

8) Support engine with a lifting device and wire ropes.

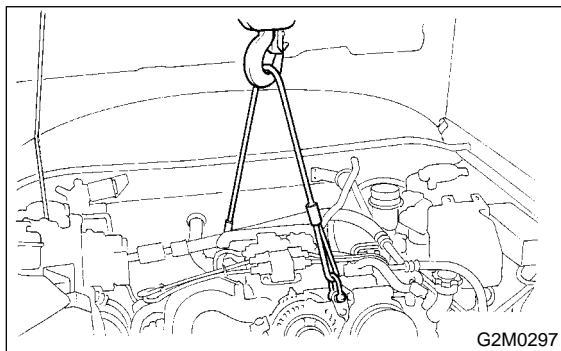

9) Lift-up the vehicle.

CAUTION:
At this time, raise up wire ropes.

10) Remove under cover.

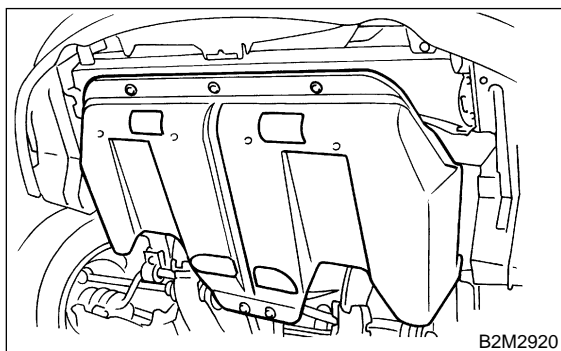

11) Drain engine oil.
Set container under the vehicle, and remove drain plug from oil pan.

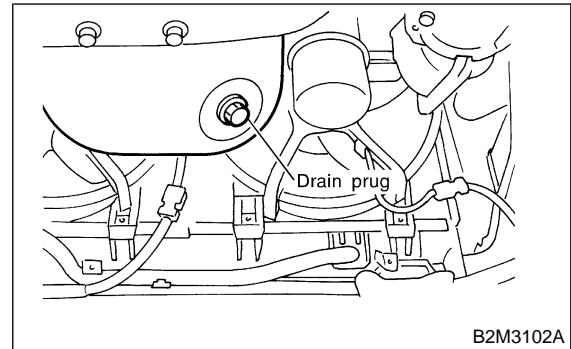

12) Disconnect connector from rear oxygen sensor.

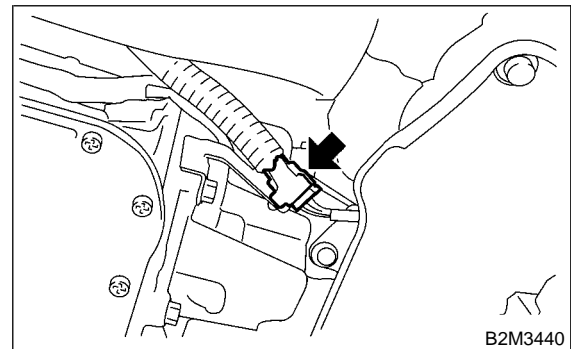

13) Remove front and center exhaust pipes. <Ref. to 2-9 [W1A0].>

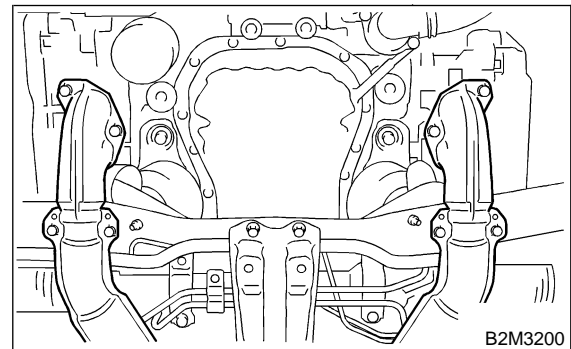

14) Remove nuts which install front cushion rubber onto front crossmember.

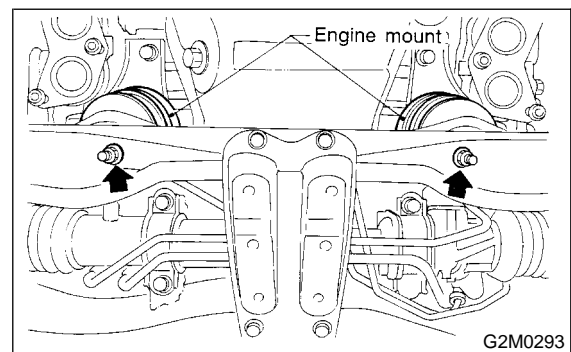

2. Oil Pan and Oil Strainer

15) Remove bolts which install oil pan on cylinder block while raising up engine.

16) Insert oil pan cutter blade between cylinder block-to-oil pan clearance.

CAUTION:

Do not use a screwdriver or similar tool in place of oil pan cutter.

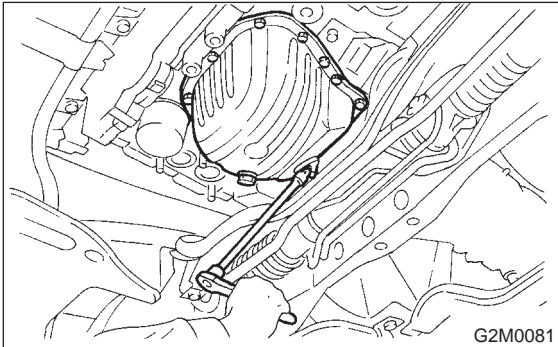

17) Remove oil strainer.

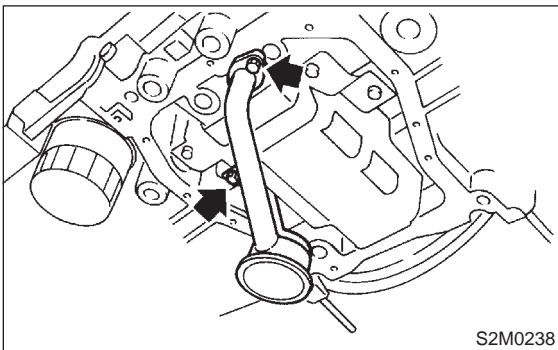

18) Remove baffle plate.

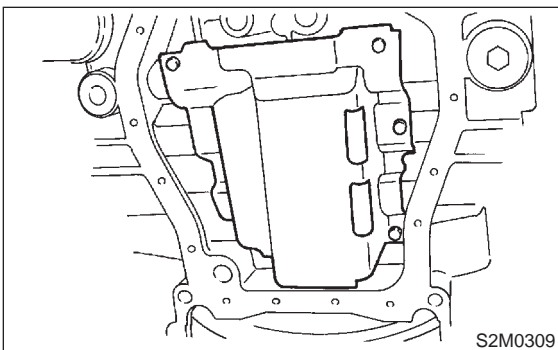
**B: INSPECTION**

By visual check make sure oil pan, oil strainer, oil strainer stay and baffle plate are not damaged.

C: INSTALLATION**CAUTION:**

Before installing oil pan, clean sealant from oil pan and engine block.

1) Install baffle plate.

Tightening torque:

6.4 N-m (0.65 kg-m, 4.7 ft-lb)

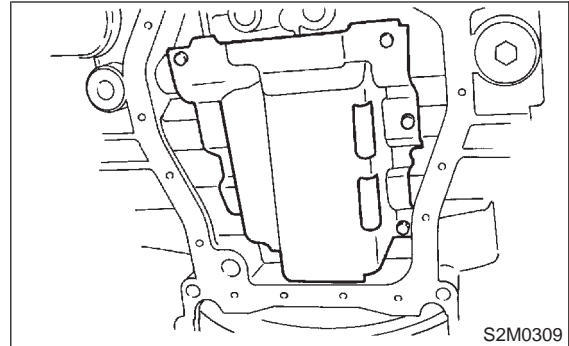

2) Install oil strainer onto baffle plate.

CAUTION:

Replace O-ring with a new one.

Tightening torque:

10 N-m (1.0 kg-m, 7 ft-lb)

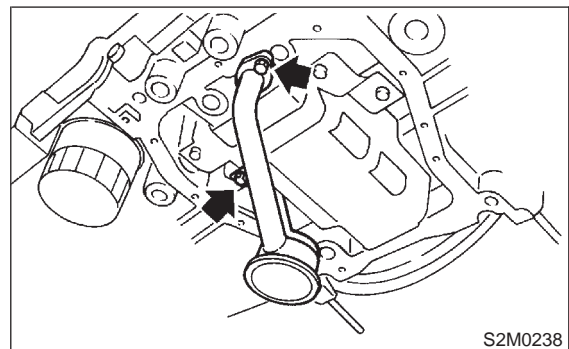

3) Apply fluid packing to mating surfaces and install oil pan.

Fluid packing:

THREE BOND 1215 or equivalent

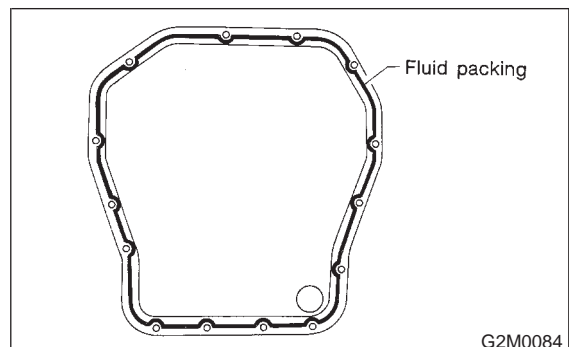

4) Tighten bolts which install oil pan onto engine block.

Tightening torque:
5 N-m (0.5 kg-m, 3.6 ft-lb)

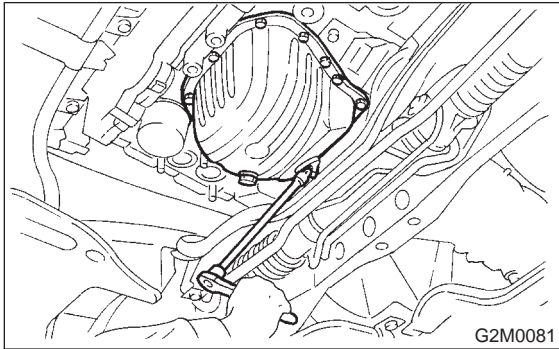

5) Lower engine onto front crossmember.
6) Tighten nuts which install front cushion rubber onto front crossmember.

Tightening torque:
69±15 N-m (7.0±1.5 kg-m, 51±11 ft-lb)

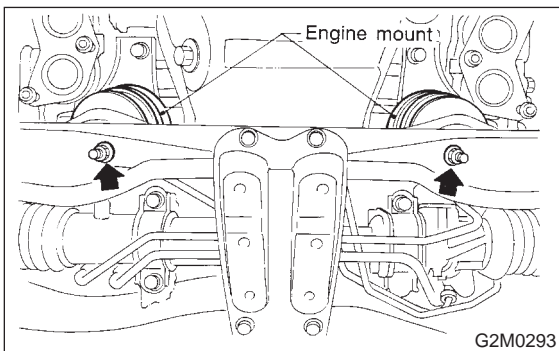

7) Install front and center exhaust pipes.
<Ref. to 2-9 [W1B0].>

CAUTION:
Always use the new gaskets.

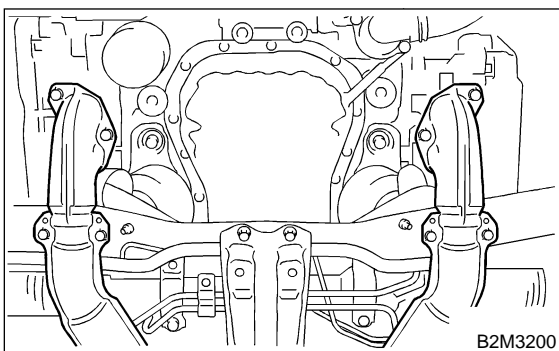

8) Connect connector to rear oxygen sensor.

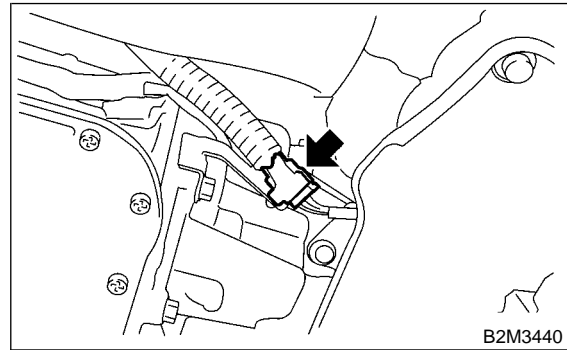

9) Install under cover.

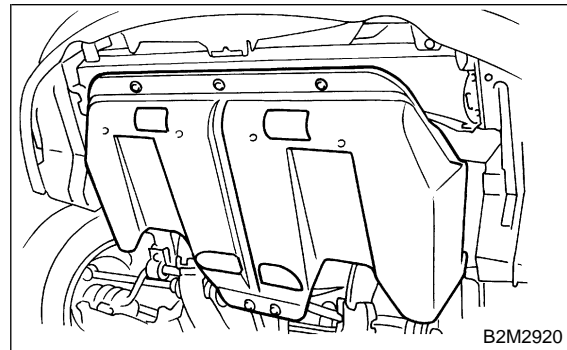

10) Lower the vehicle.

CAUTION:
At this time, lower lifting device and release steel cables.

11) Remove lifting device and steel cables.

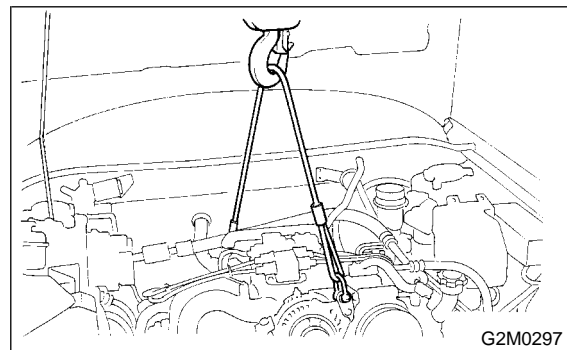

12) Connect connector to front oxygen (A/F) sensor.

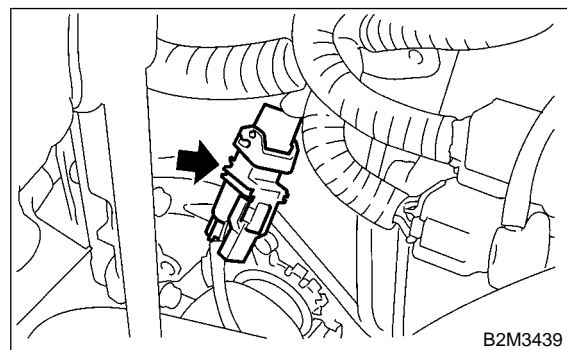

2. Oil Pan and Oil Strainer

13) Install pitching stopper.

Tightening torque:

T1: 49 ± 5 N·m (5.0 ± 0.5 kg·m, 36.2 ± 3.6 ft·lb)

T2: 57 ± 10 N·m (5.8 ± 1.0 kg·m, 42 ± 7 ft·lb)

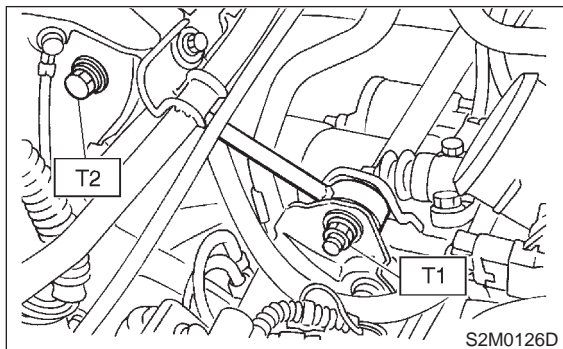

14) Install radiator upper brackets.

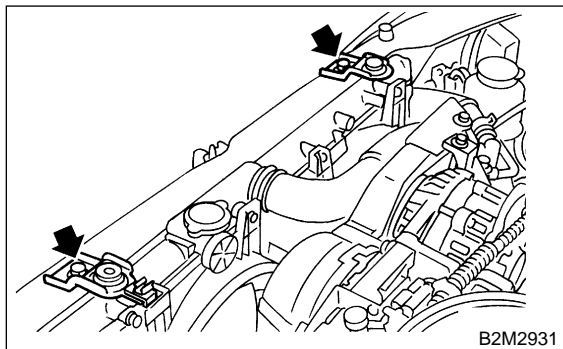

15) Install air intake duct.

<Ref. to 2-7 [W1A0].>

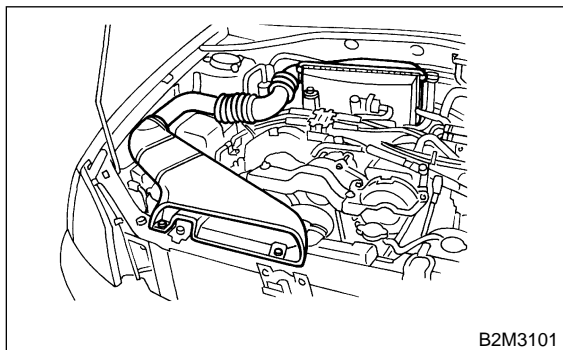

16) Install front wheels.

17) Connect battery ground cable.

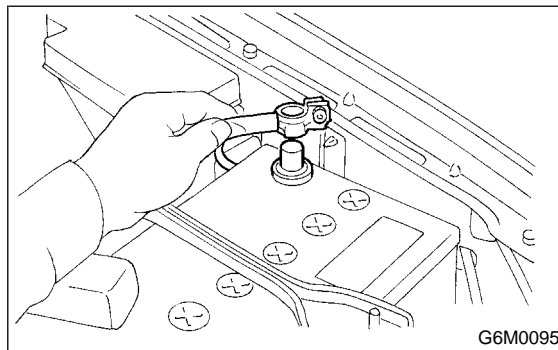

18) Fill engine oil. <Ref. to 1-5 [G4A0].>