

2. Fuel Filler Pipe

A: REMOVAL

WARNING:

- Place "NO FIRE" signs near the working area.
- Be careful not to spill fuel on the floor.

- 1) Set the vehicle on the lift.
- 2) Disconnect battery ground cable.

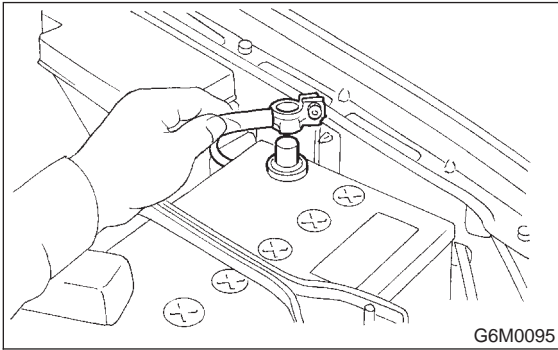

- 3) Open fuel filler flap lid and remove filler cap.

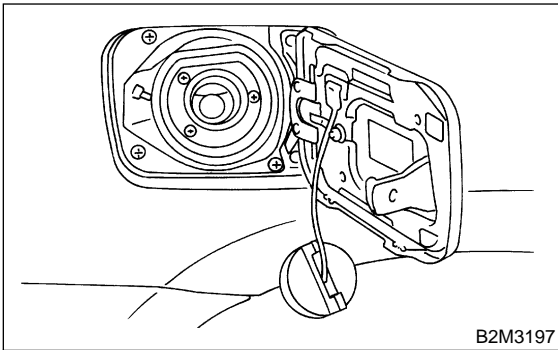

- 4) Remove screws holding packing in place.

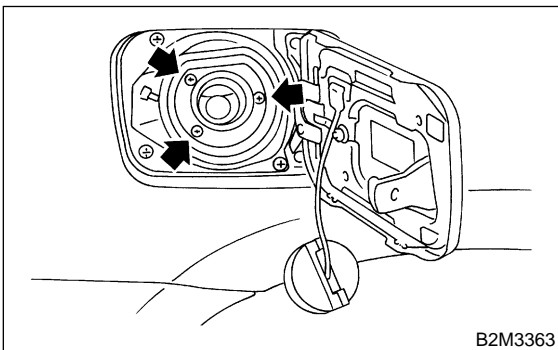

- 5) Lift-up the vehicle.
- 6) Remove rear wheel nuts.
- 7) Remove rear wheel.

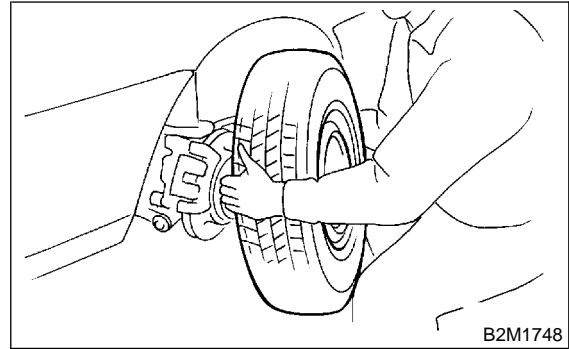

- 8) Remove front right side fuel tank cover.

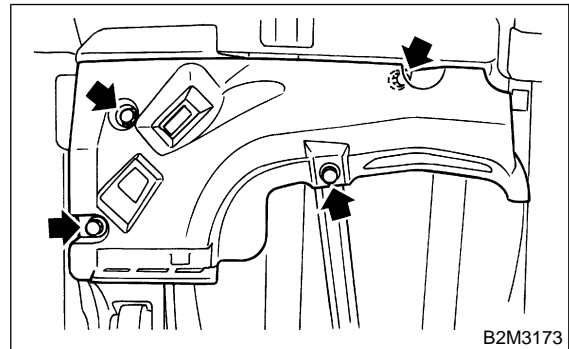

- 9) Drain fuel from fuel tank. Set a container under the vehicle and remove drain plug from fuel tank.

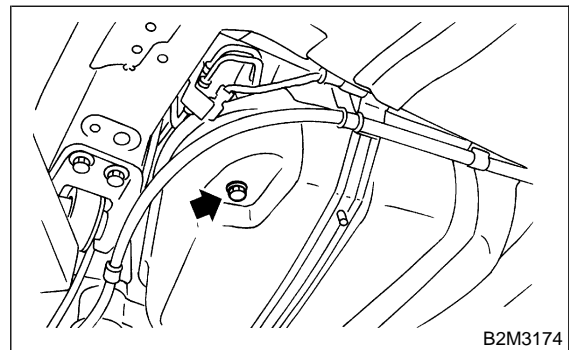

10) Tighten fuel drain plug and then install front right side tank cover.

Tightening torque:

26 ± 7 N·m (2.65 ± 0.7 kg·m, 19.2 ± 5.1 ft·lb)

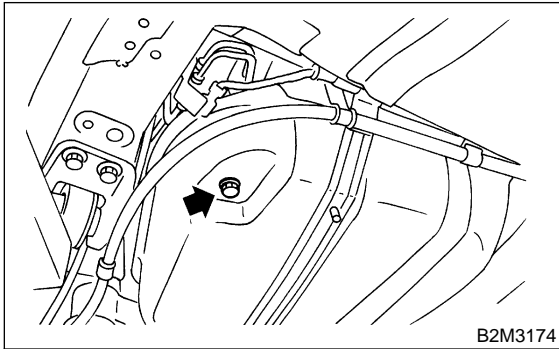

Tightening torque:

18 ± 5 N·m (1.8 ± 0.5 kg·m, 13.0 ± 3.6 ft·lb)

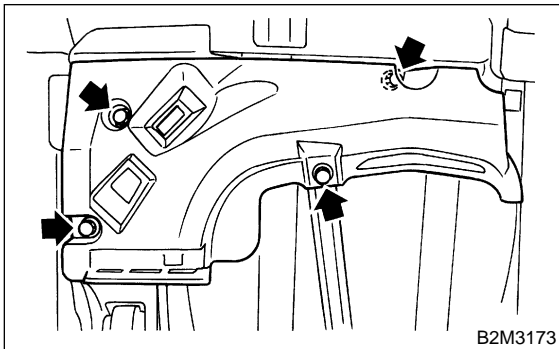

11) Remove rear exhaust pipe and muffler.

NOTE:

To facilitate removal, apply a coat of SUBARU CRC to matching area of rubber cushions in advance.

SUBARU CRC (Part No. 004301003)

(1) Separate rear exhaust pipe from center exhaust pipe.

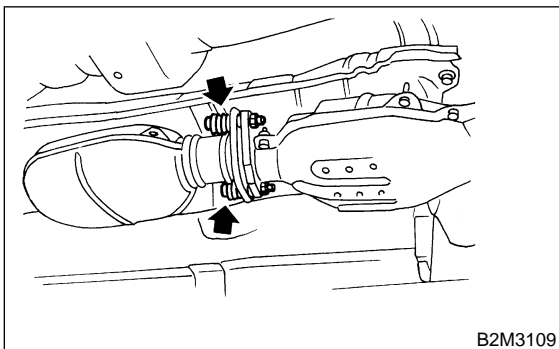

(2) Remove left and right rubber cushions.

CAUTION:

Be careful not to pull down muffler.

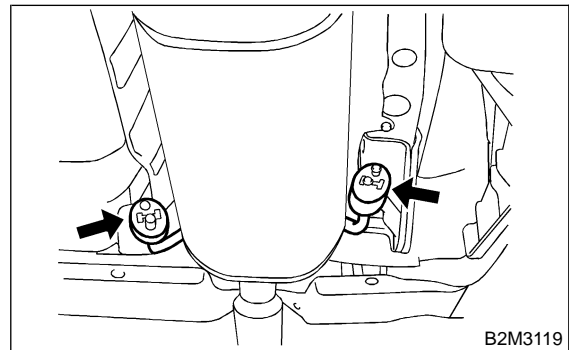

(3) Remove front rubber cushion and detach muffler assembly.

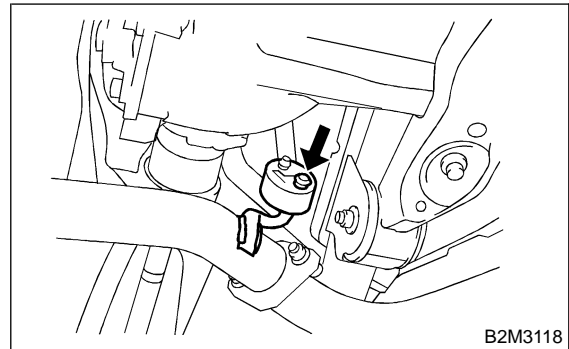

12) Remove heat sealed cover.

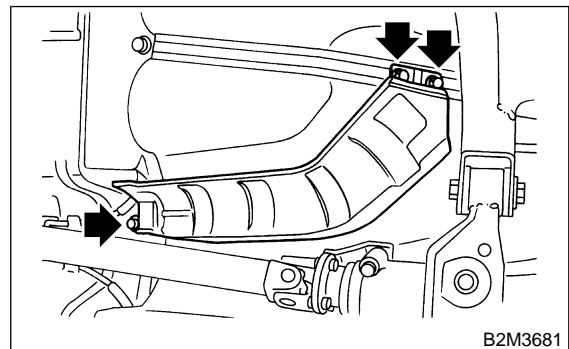

13) Place transmission jack under sub frame.

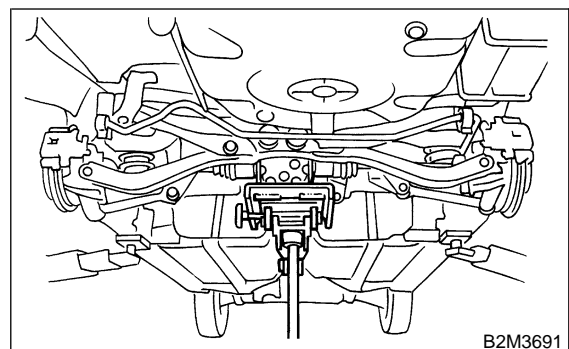

14) Remove bolt which holds rear shock absorber to rear suspension arm.

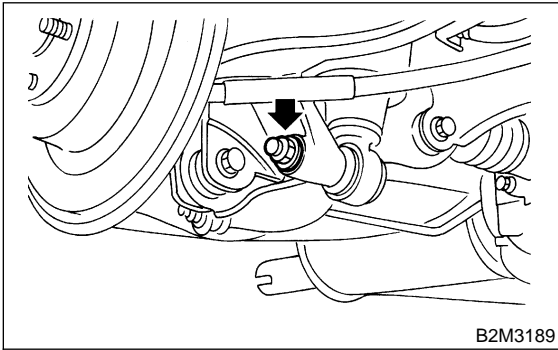

15) Remove bolts which hold rear sub frame on body.

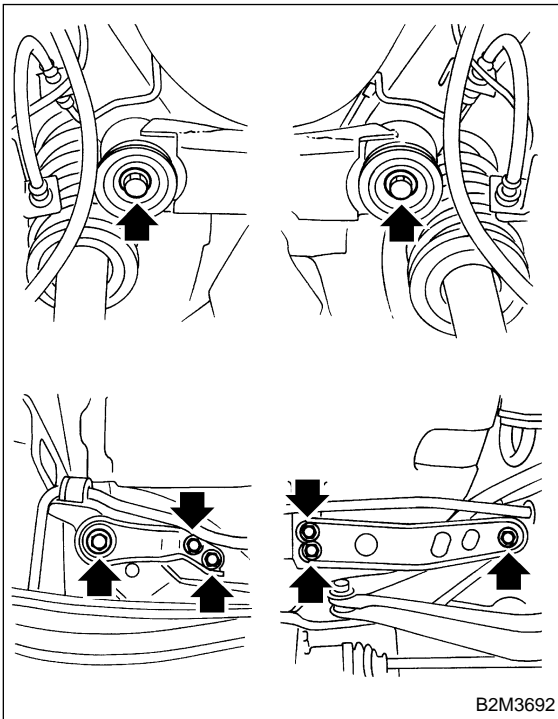

16) Lower the rear sub frame.

CAUTION:
Be sure to lower sub frame slowly.

A = 150 mm (5.91 in)

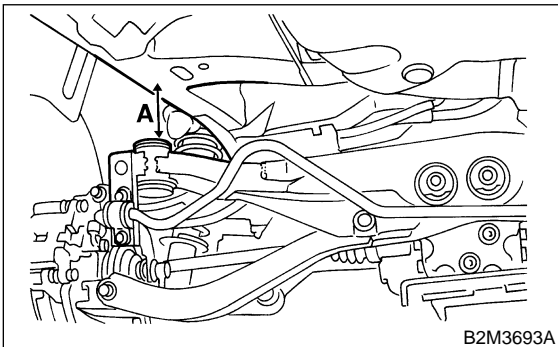

17) Remove fuel filler pipe protector.

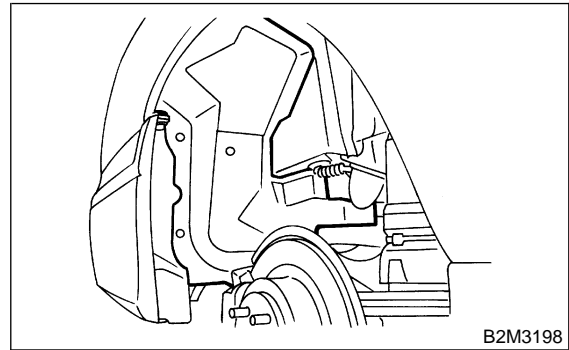

18) Disconnect air vent hose (A) and evaporation hose (H) from evaporation pipe assembly.

19) Disconnect evaporation hose (I) from pressure control solenoid valve.

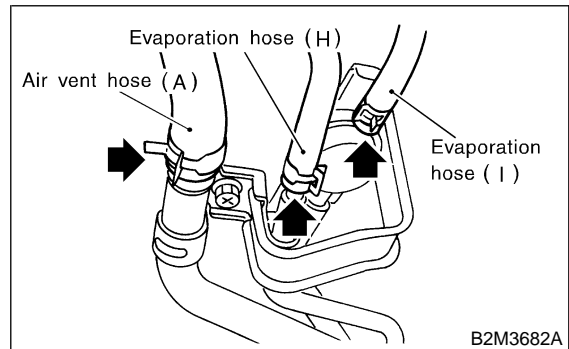

20) Remove bolt which holds evaporation pipe assembly on body.

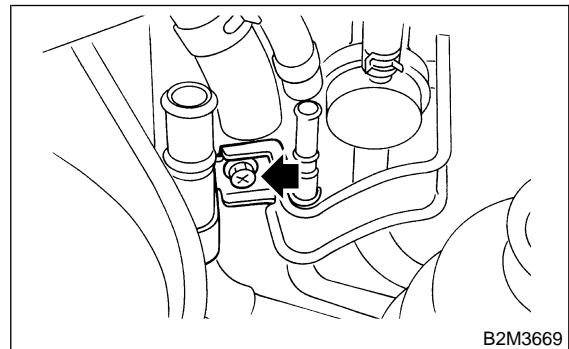

- 21) Disconnect fuel filler hose.
- 22) Remove bolt which holds fuel pressure sensor on fuel filler pipe and remove bolt which holds fuel filler pipe on body.

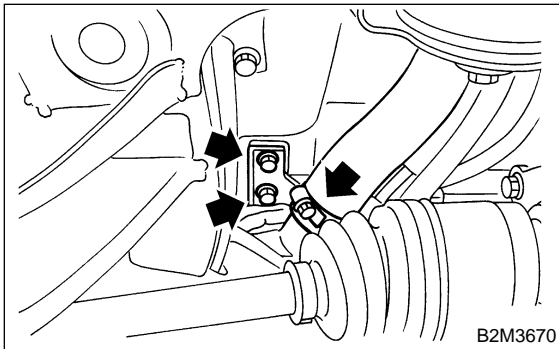

- 23) Disconnect canister hose from evaporation pipe assembly.

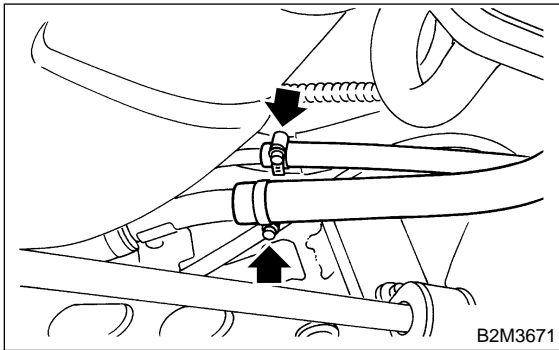

- 24) Disconnect evaporation hose (O) from fuel filler pipe.

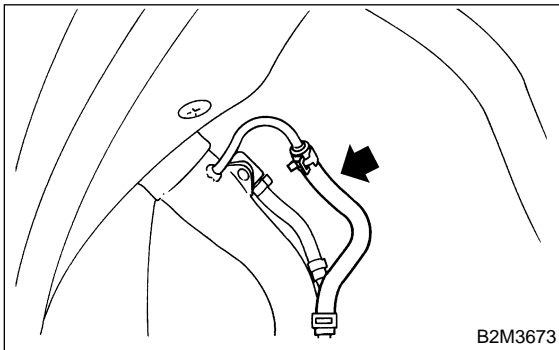

- 25) Remove bolt which holds fuel filler pipe to body.

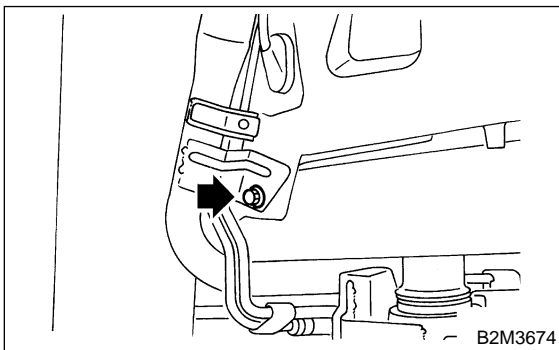

- 26) Remove fuel filler pipe to under side of the vehicle.

B: DISASSEMBLY AND ASSEMBLY

- 1) Disconnect evaporation hose (M) and (N) from evaporation pipe assembly.

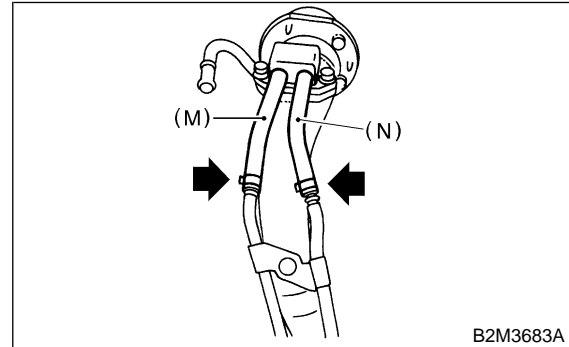

- 2) Remove shut valve from fuel filler pipe.

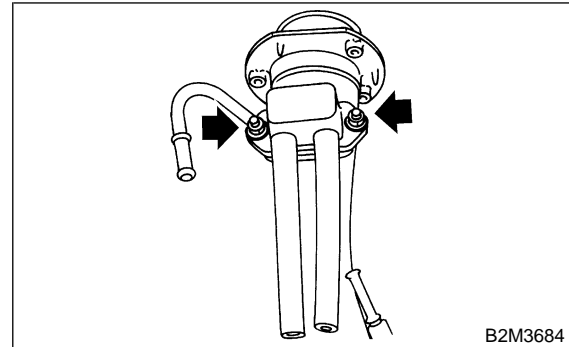

- 3) Remove nut which holds evaporation pipe assembly on fuel filler pipe.

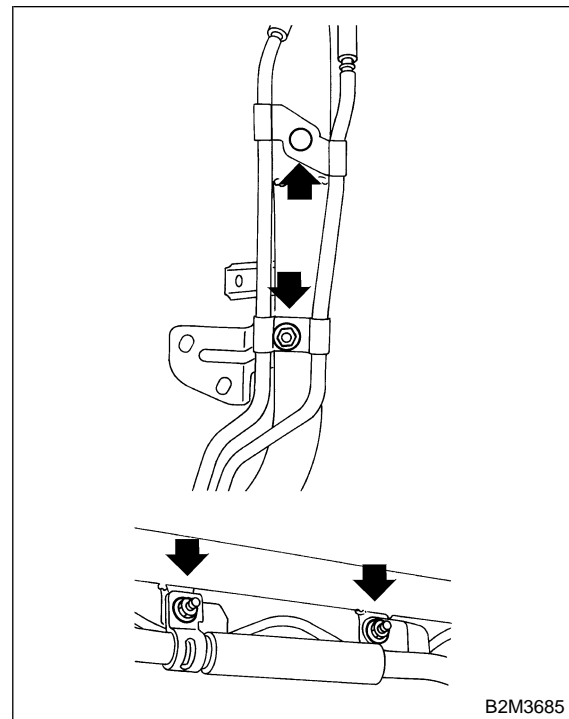

4) Assembly is in the reverse order of disassembly.

C: INSTALLATION

- 1) Hold fuel filler flap open.
- 2) Set fuel saucer (A) with rubber packing (C) and insert fuel filler pipe into hole from the inner side of apron.

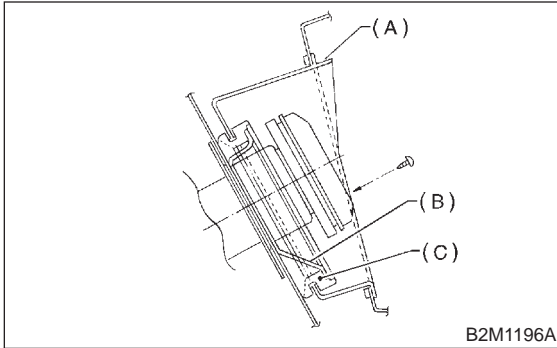

3) Align holes in fuel filler pipe neck and set cup (B), and tighten screws.

NOTE:

If edges of rubber packing are folded toward the inside, straighten it with a screwdriver.

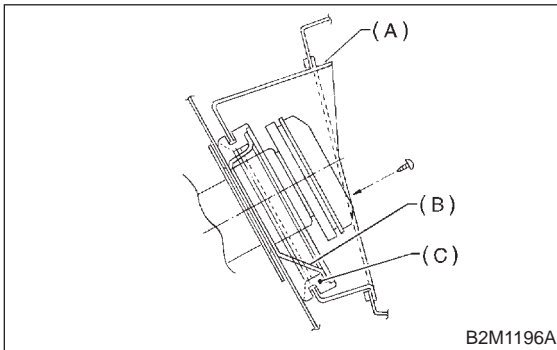

4) Tighten bolt which holds fuel filler pipe on body.

Tightening torque:

$7.5 \pm 2.0 \text{ N}\cdot\text{m}$ ($0.75 \pm 0.2 \text{ kg}\cdot\text{m}$, $5.4 \pm 1.4 \text{ ft}\cdot\text{lb}$)

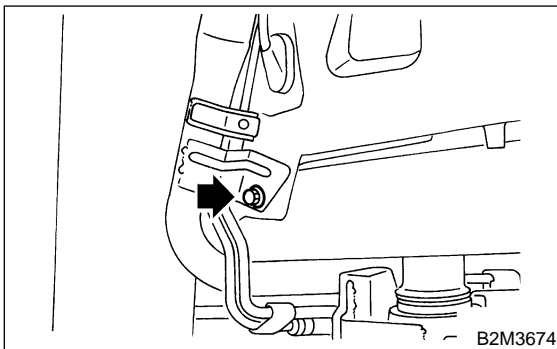

5) Insert evaporation hose (O) approximately 25 to 30 mm (0.98 to 1.18 in) into the lower end of evaporation pipe and hold clip.

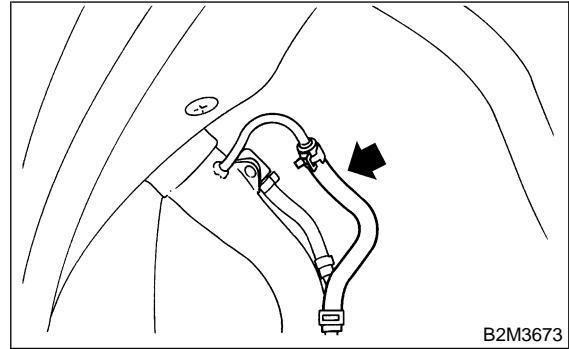

$L = 27.5 \pm 2.5 \text{ mm}$ ($1.083 \pm 0.098 \text{ in}$)

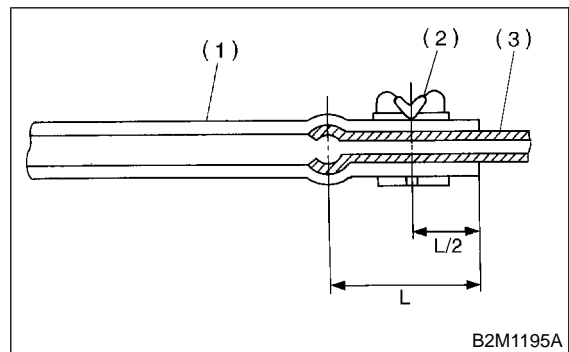

- (1) Hose
- (2) Clip
- (3) Pipe

6) Insert canister hoses approximately 25 to 30 mm (0.98 to 1.18 in) into the lower end of evaporation pipe assembly and tighten clamp.

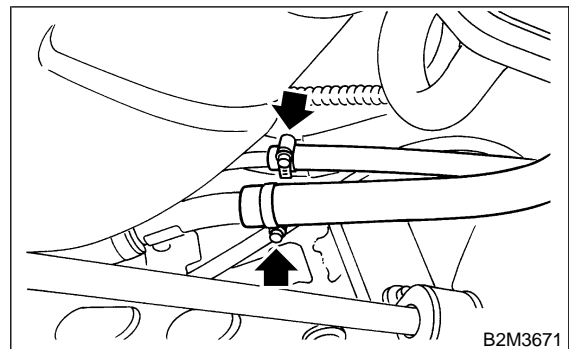

$L = 27.5 \pm 2.5 \text{ mm (1.083 \pm 0.098 in)}$

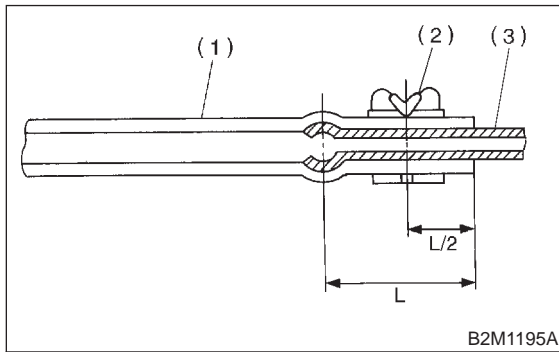

- (1) Hose
- (2) Clip
- (3) Pipe

7) Tighten bolt which holds evaporation pipe assembly on body.

Tightening torque:

$7.5 \pm 2.0 \text{ N}\cdot\text{m (0.75 \pm 0.2 kg}\cdot\text{m, 5.4 \pm 1.4 ft}\cdot\text{lb)}$

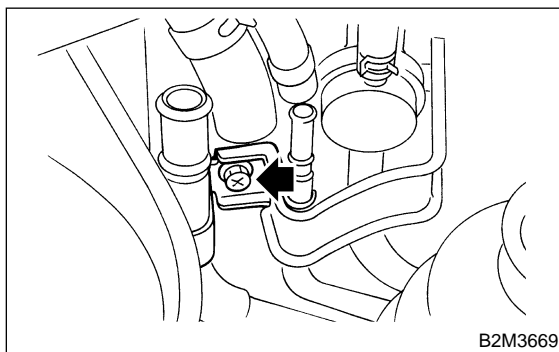

8) Insert air vent hose (A), evaporation hose (H) approximately 25 to 30 mm (0.98 to 1.18 in) into the lower end of evaporation pipe assembly and hold clip.

9) Insert evaporation hose (I) to pressure control solenoid valve and hold clip.

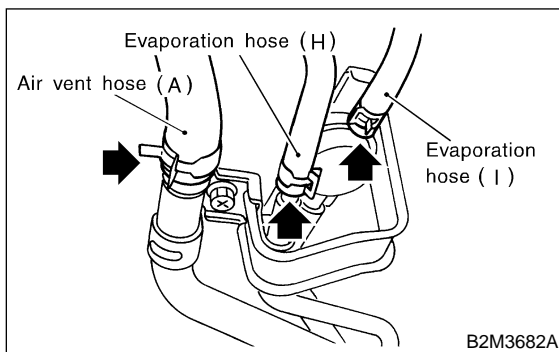

$L = 27.5 \pm 2.5 \text{ mm (1.083 \pm 0.098 in)}$

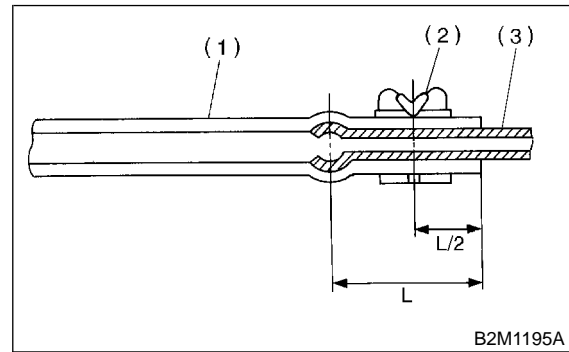

- (1) Hose
- (2) Clip
- (3) Pipe

10) Tighten bolt which holds fuel filler pipe on body and tighten bolt which holds fuel pressure sensor on fuel filler pipe.

Tightening torque:

$7.5 \pm 2.0 \text{ N}\cdot\text{m (0.75 \pm 0.2 kg}\cdot\text{m, 5.4 \pm 1.4 ft}\cdot\text{lb)}$

11) Insert fuel filler hose approximately 35 to 40 mm (1.38 to 1.57 in) over the lower end of fuel filler pipe and tighten clamp.

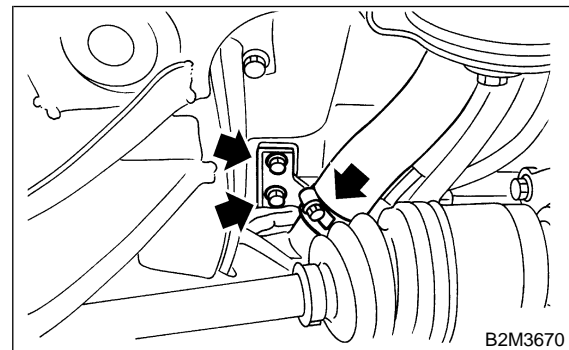

12) Jack-up the rear sub frame and tighten bolts which hold rear sub frame on body.

Tightening torque:

T1: 66 ± 10 N-m (6.7 ± 1.0 kg-m, 48.5 ± 7.2 ft-lb)

T2: 172 ± 20 N-m (17.5 ± 2 kg-m, 127 ± 14 ft-lb)

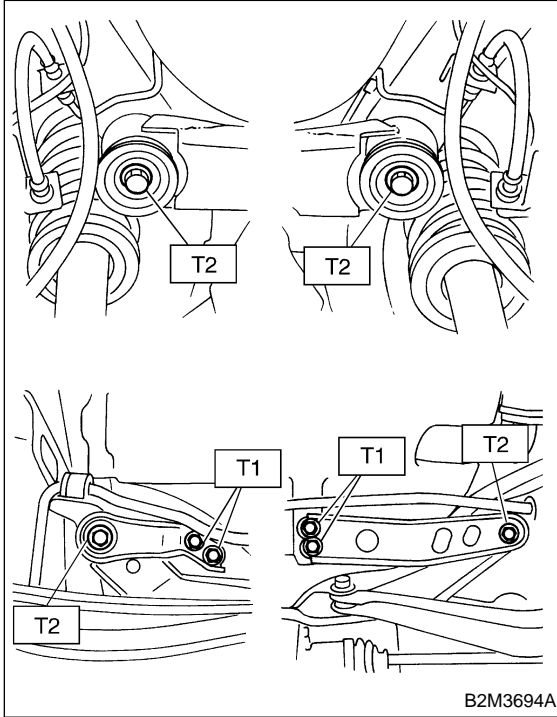

13) Tighten bolt which holds rear shock absorber to rear suspension arm. <Ref. to 4-1 [W11E0].>

Tightening torque:

157 ± 20 N-m (16 ± 2 kg-m, 116 ± 14 ft-lb)

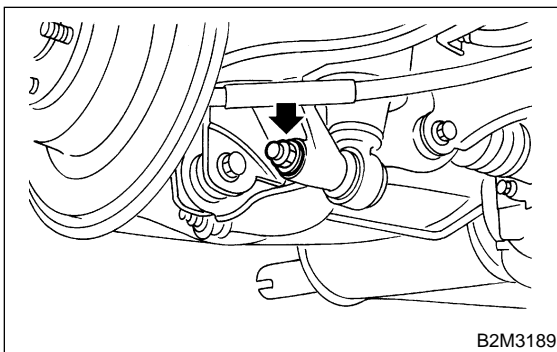

14) Install heat shield cover.

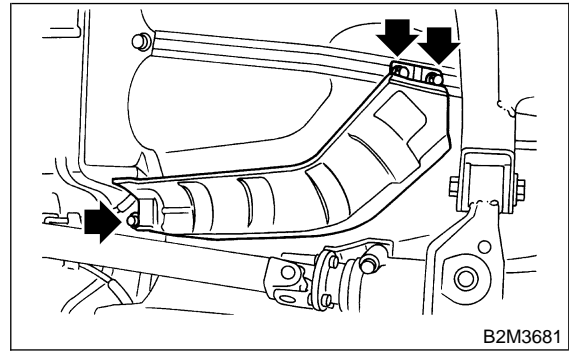

15) Install rear exhaust pipe and muffler.

NOTE:

To facilitate the procedure, apply a coat of SUBARU CRC to matching area of rubber cushions in advance.

SUBARU CRC (Part No. 004301003)

(1) Install left and right rubber cushions.

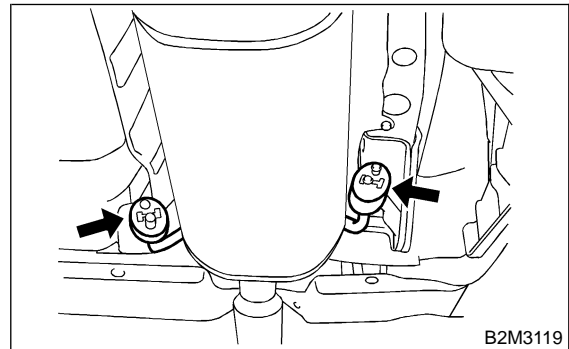

(2) Install front rubber cushion and attach muffler assembly.

