

1. Pedal and Accelerator Pedal

A: ON-CAR SERVICE

1. BRAKE PEDAL

1) Check position of pedal pad.

Pedal height: L
148 mm (5.83 in)

Brake pedal free play: A
1 — 3 mm (0.04 — 0.12 in) [Depress brake pedal pad with a force of less than 10 N (1 kg, 2 lb).]

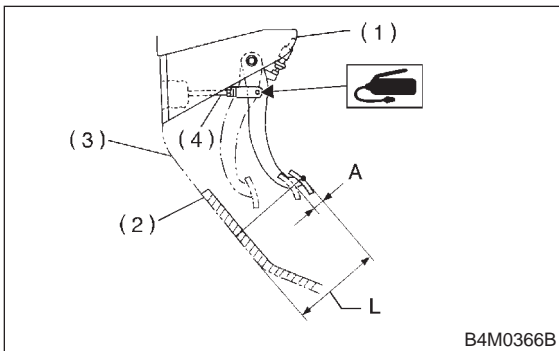

- (1) Stop light switch
- (2) Mat
- (3) Toe board
- (4) Brake booster operating rod

2) If it is not in specified value, adjust it by adjusting brake booster operating rod length.
 3) Measure the clearance between threaded end of stop light switch and stopper.

CAUTION:
Be careful not to rotate stop light switch.

Stop light switch clearance: A
0.3 mm (0.012 in)

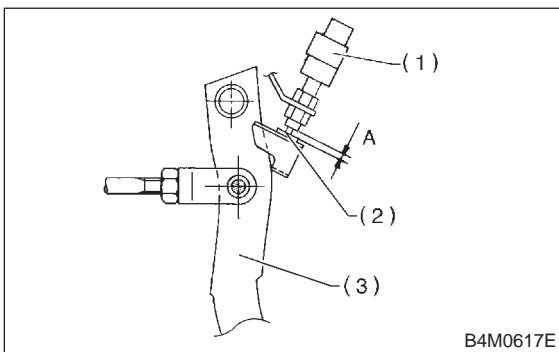

- (1) Stop light switch
- (2) Stopper
- (3) Brake pedal

4) If it is not in specified value, adjust it by adjusting position of stop light switch.

CAUTION:
Be careful not to rotate stop light switch.

Stop light switch lock nut tightening torque:
8±2 N·m (0.8±0.2 kg·m, 5.8±1.4 ft·lb)

5) Apply grease to operating rod connecting pin to prevent it from wearing.

2. CLUTCH PEDAL

1) Push release fork until operating cylinder push rod retracts. Check that clutch fluid level in reservoir tank increases.

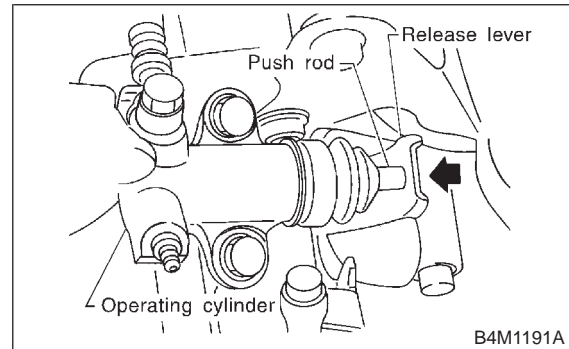

2) If clutch fluid level increases, hydraulic clutch play is correct.
 3) If clutch fluid level does not increase or push rod does not retract, clutch pedal must be adjusted. <Ref. to 4-5 [W1F1].>
 4) Check the fluid level on the outside of the clutch master cylinder tank. If the level is below "MIN", add clutch fluid to bring it up to "MAX".

Recommended clutch fluid:
FMVSS No. 116, fresh DOT 3 or DOT 4 brake fluid

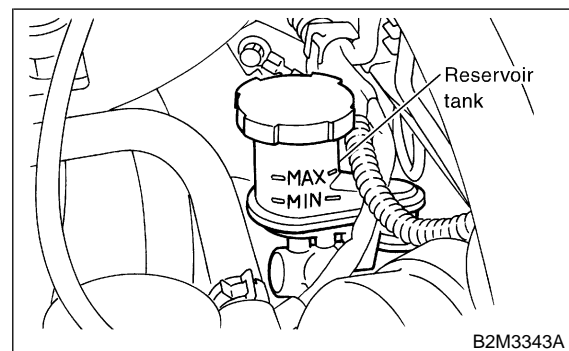

1. Pedal and Accelerator Pedal

3. ACCELERATOR PEDAL

Check pedal stroke and free play by operating accelerator pedal by hand.
If it is not within specified value, adjust it by turning nut connecting accelerator cable to throttle body.

Free play at pedal pad: L
1 — 4 mm (0.04 — 0.16 in)

Stroke at pedal pad: A
50 — 55 mm (1.97 — 2.17 in)

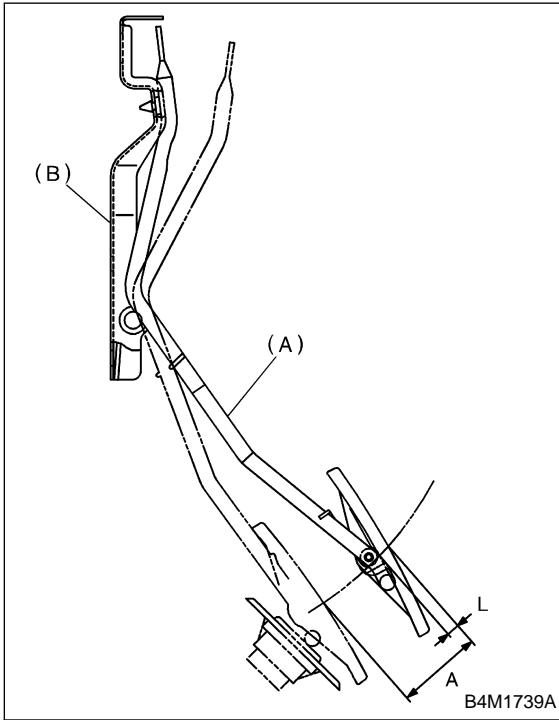

(A) Accelerator pedal
(B) Accelerator pedal bracket

Accelerator cable lock nut tightening torque:
14±4 N·m (1.4±0.4 kg·m, 10.1±2.9 ft·lb)

B: REMOVAL

1. ACCELERATOR PEDAL

- 1) Disconnect ground cable from battery.
- 2) Remove lock nut from accelerator cable bracket.
- 3) Separate accelerator cable from bracket.
- 4) Remove accelerator cable end from throttle cam.
- 5) Disconnect accelerator cable from throttle body.

CAUTION:
Be careful not to kink accelerator cable.

- 6) Remove clip inside engine compartment.

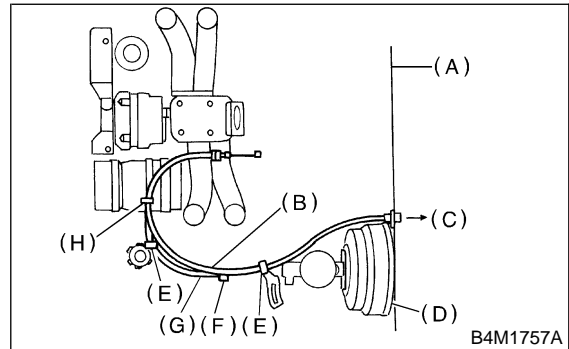

(A) Toe board
(B) Accelerator cable (With A/C)
(C) To accelerator cable
(D) Brake booster
(E) Clip
(F) Clip (Only model without A/C)
(G) Accelerator cable (Without A/C)
(H) Clip (Only mode with A/C)

- 7) Remove instrument panel lower cover from instrument panel, and connector.
- 8) Remove brake and clutch pedal bracket. (MT model) <Ref. to 4-5 [W1B2].>
- 9) Remove accelerator pedal connecting bolt from accelerator pedal bracket.

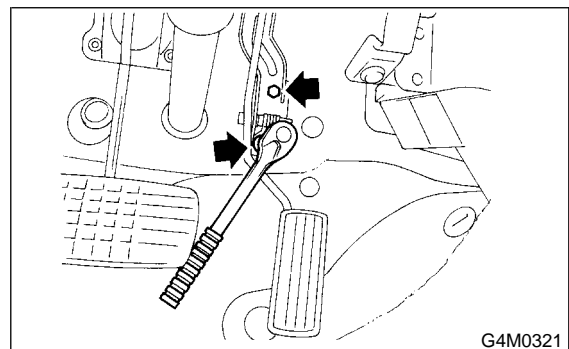

10) Disconnect grommet from toe board.

NOTE:

From inside compartment, push grommet into hole.

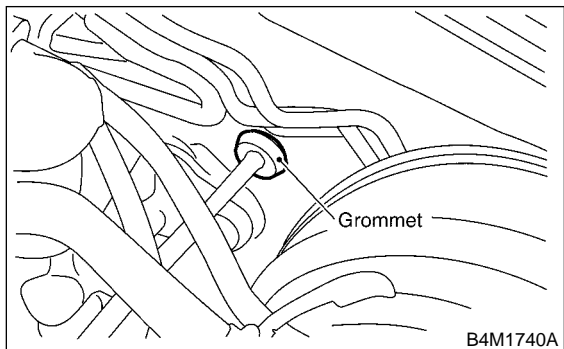

11) Pull out the cable from the toe board hole.
12) Disconnect accelerator cable bushing from accelerator pedal lever.

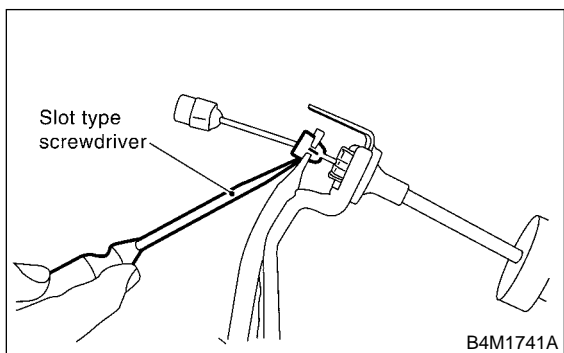

13) Disconnect accelerator cable stopper from bracket.

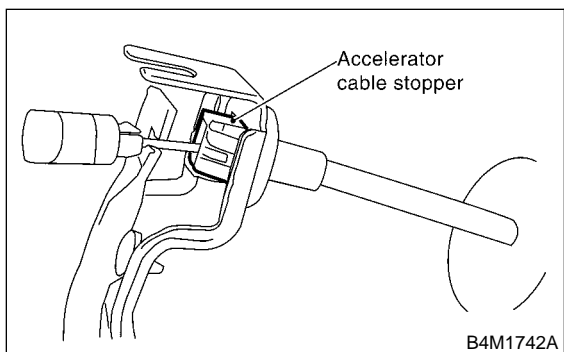

14) Separate accelerator cable and bracket.

2. BRAKE AND CLUTCH PEDAL (MT MODEL)

- 1) Remove steering column. <Ref. to 4-3 [W2A0].>
- 2) Disconnect connectors from stop light and clutch switches.
- 3) Remove snap pins which secure lever to push rod and operating rod.

4) Remove clevis pins which secure lever to push rod and operating rod.

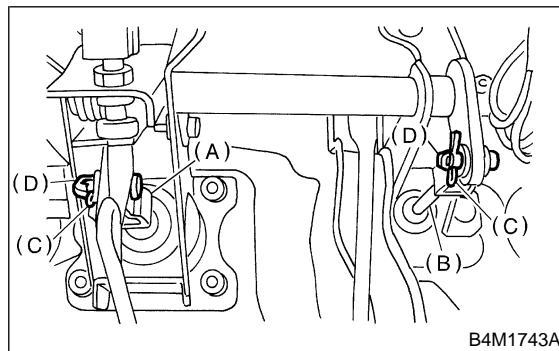

- (A) Operating rod
- (B) Push rod
- (C) Snap pin
- (D) Clevis pin

5) Remove nut which secures clutch master cylinder.

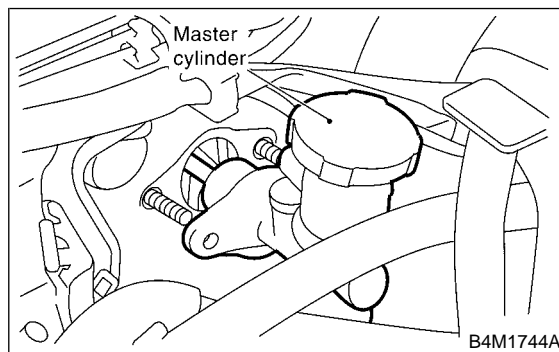

6) Remove bolts and nuts which secure brake and clutch pedals, and remove pedal assembly.

3. BRAKE PEDAL (AT MODEL)

- 1) Disconnect ground cable from battery.
- 2) Remove instrument panel lower cover from instrument panel.
- 3) Remove clevis pin which secures brake pedal to brake booster operating rod. Also disconnect stop light switch connector.
- 4) Remove two bolts and four nuts which secure brake pedal to pedal.

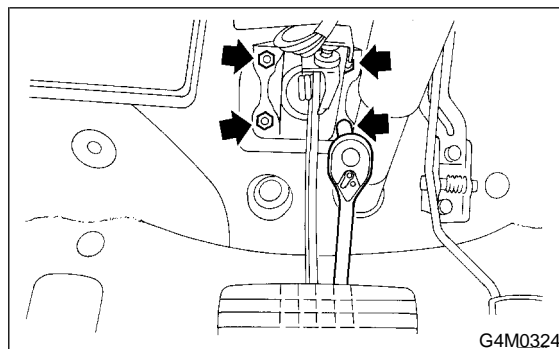

C: INSPECTION

1. BRAKE AND CLUTCH PEDALS

Move brake and clutch pedal pads in the lateral direction with a force of approximately 10 N (1 kg, 2 lb) to ensure pedal deflection is in specified range.

CAUTION:

If excessive deflection is noted, replace bushings with new ones.

Deflection of brake and clutch pedal:

Service limit

5.0 mm (0.197 in) or less

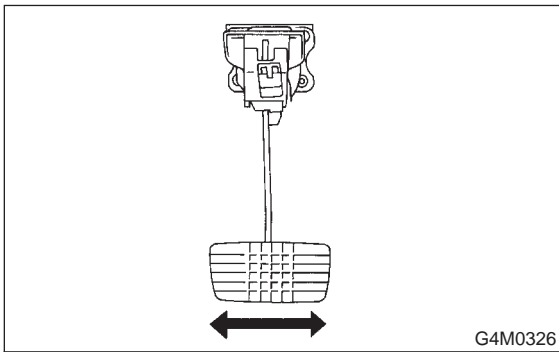
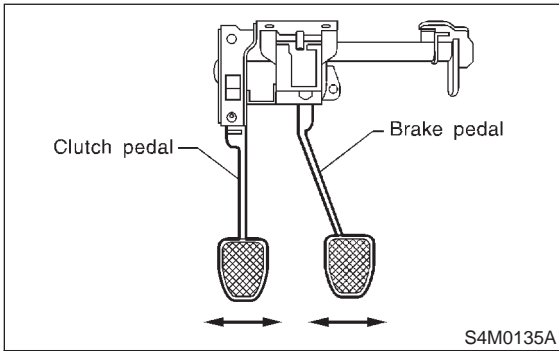

2. ACCELERATOR PEDAL

Lightly move pedal pad in lateral the direction to ensure pedal deflection is in specified range.

CAUTION:

If excessive deflection is noted, replace bushing and clip with new ones.

Deflection of accelerator pedal:

Service limit

5.0 mm (0.197 in) or less

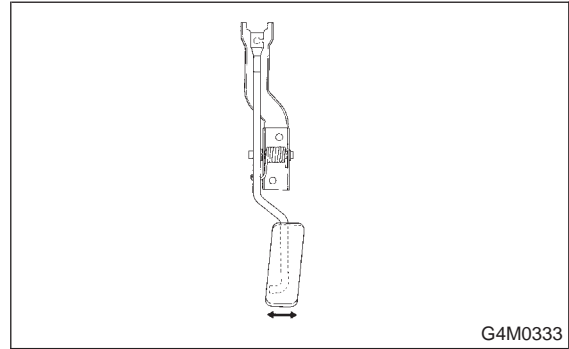

3. STOP LIGHT SWITCH

If stop light switch does not operate properly (or if it does not stop at the specified position), replace with a new one.

Specified position: L

$2^{+1.5}/_0$ mm ($0.079^{+0.059}/_0$ in)

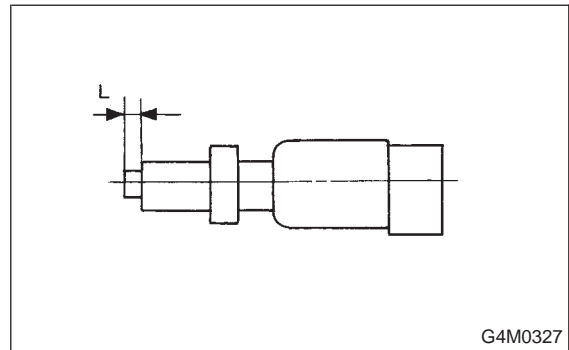

D: ASSEMBLY

1. BRAKE AND CLUTCH PEDALS

- 1) Attach stop light switch, etc. to pedal bracket temporarily.
- 2) Clean inside of bores of clutch pedal and brake pedal, apply grease, and set bushings into bores.
- 3) Align bores of pedal bracket, clutch pedal and brake pedal, attach brake pedal return spring and clutch pedal effort reducing spring (vehicle with hill holder), and then install pedal bolt.

NOTE:

Clean up inside of bushings and apply grease before installing spacer.

Tightening torque:

T: 29±7 N-m (3.0±0.7 kg-m, 21.7±5.1 ft-lb)

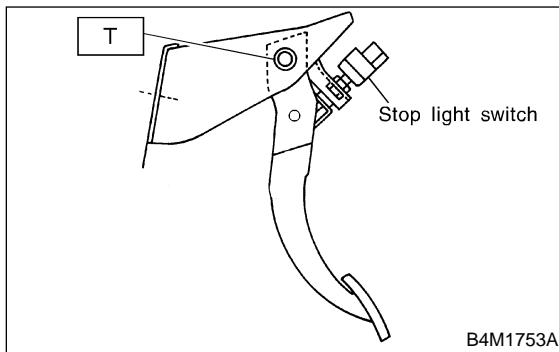

- 4) Set brake pedal position by adjusting position of stop light switch.

Pedal position: L

125.9 mm (4.96 in)

Tightening torque:

T: 8±2 N-m (0.8±0.2 kg-m, 5.8±1.4 ft-lb)

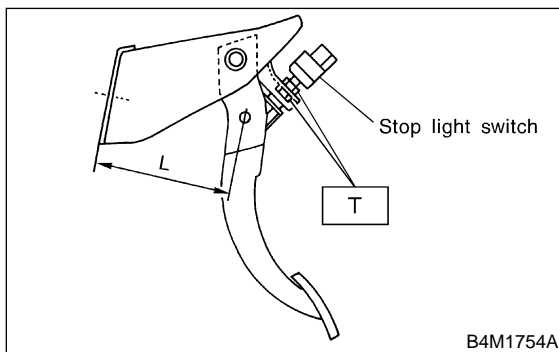

2. ACCELERATOR PEDAL

Clean and apply grease to spacer and inside bore of accelerator pedal. Install accelerator pedal onto pedal bracket.

E: INSTALLATION

- 1) Installation is in the reverse order of removal procedures.

CAUTION:

- If cable clamp is damaged, replace it with a new one.
- Never fail to cover outer cable end with boot.
- Be careful not to kink accelerator cable.
- Always use new clevis pins.

- 2) Adjustment of clutch pedal <Ref. to 4-5 [W1F1].>

- 3) Adjustment after pedal installation <Ref. to 4-5 [W1A0].>

F: ADJUSTMENT

1. CLUTCH PEDAL

- 1) Turn cruise control clutch switch lock nuts until clutch pedal full stroke length is within specifications.

CAUTION:

Do not attempt to turn clutch switch to adjust clutch pedal full stroke length.

NOTE:

If lock nuts cannot adjust clutch pedal full stroke length to specifications, turn master cylinder push rod to adjust it.

Specified clutch pedal full stroke: A

130 — 135 mm (5.12 — 5.31 in)

Tightening torque (Clutch switch lock nut):

8±2 N-m (0.8±0.2 kg-m, 5.8±1.4 ft-lb)

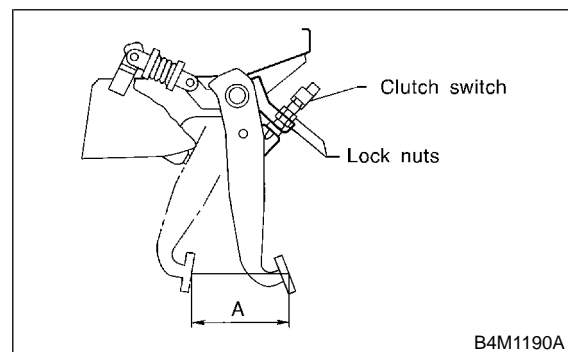

1. Pedal and Accelerator Pedal

2) Turn master cylinder push rod so that clevis pin moves to the left and then to the right. Clevis pin must move without resistance while it is rattling.

Tightening torque (Push rod lock nut):
 $8 \pm 2 \text{ N}\cdot\text{m}$ ($0.8 \pm 0.2 \text{ kg}\cdot\text{m}$, $5.8 \pm 1.4 \text{ ft}\cdot\text{lb}$)

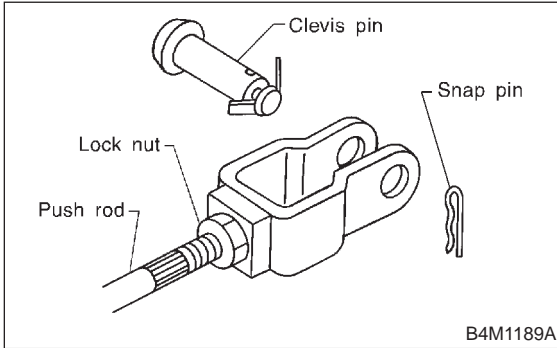

3) Depress and release clutch pedal 2 to 3 times to ensure that clutch pedal and release fork operate smoothly. If clutch pedal and release fork do not operate smoothly, bleed air from clutch hydraulic system. <Ref. to 2-10 [W2A0].>

4) Measure clutch pedal full stroke length again to ensure that it is within specifications. If it is not, repeat adjustment procedures again from the beginning.

Specified clutch pedal full stroke:
 $130 - 135 \text{ mm}$ ($5.12 - 5.31 \text{ in}$)

5) Move clevis pin to the left and then to the right. It should move without resistance while it is rattling. If resistance is felt, repeat adjustment procedures again from the beginning.

6) Push release lever until operating cylinder push rod retracts. Ensure that clutch fluid level in reservoir tank increases. If clutch fluid level increases, hydraulic clutch is properly adjusted; if fluid level does not increase or push rod does not retract, replace master cylinder with new one. <Ref. to 2-10 [W600].>

