

**3-2 [M1200]****MECHANISM AND FUNCTION****12. Transmission Control Module (TCM)****12. Transmission Control Module (TCM)**

TCM receives various sensor signals and determines the running conditions of the vehicle. It then sends control signals to each solenoid according to the preset gearshift characteristic data, lock-up operation data, and transfer clutch torque data (duty ratio).

**A: CONTROL SYSTEM**

Control item		Input signal
Shift control	Ordinary shift control	Throttle position sensor Vehicle speed sensor 1 (rear) Vehicle speed sensor 2 (front) Engine speed Inhibitor switch
	ABS operation control	ABS signal Throttle position sensor Vehicle speed sensor 1 (rear) Vehicle speed sensor 2 (front) Brake switch
	Hydraulic oil temperature control	ATF temperature sensor
	Reverse inhibit control	Throttle position sensor Vehicle speed sensor 1 (rear) Vehicle speed sensor 2 (front) Inhibitor switch
	Shift pattern select control	Throttle position sensor Vehicle speed sensor 1 (rear) Vehicle speed sensor 2 (front) Inhibitor switch
	Grade control	Throttle position sensor Vehicle speed sensor 1 (rear) Vehicle speed sensor 2 (front) Brake switch Inhibitor switch
Lock-up control	Ordinary lock-up control	Throttle position sensor Vehicle speed sensor 1 (rear) Vehicle speed sensor 2 (front) Engine speed Inhibitor switch
	Smooth control	Throttle position sensor
	Hydraulic oil temperature control	ATF temperature sensor
Oil pressure control	Ordinary pressure control	Throttle position sensor Vehicle speed sensor 1 (rear) Vehicle speed sensor 2 (front) Engine speed Inhibitor switch ATF temperature sensor
	Shifting control	Throttle position sensor Vehicle speed sensor 1 (rear) Vehicle speed sensor 2 (front) Engine speed Torque converter turbine speed sensor Inhibitor switch ATF temperature sensor
	Starting control	Engine speed ATF temperature sensor Inhibitor switch

**MECHANISM AND FUNCTION****[M12A0] 3-2****12. Transmission Control Module (TCM)**

Control item		Input signal
Oil pressure control	Learning control	Shift solenoid A Shift solenoid B Vehicle speed sensor 1 (rear) Vehicle speed sensor 2 (front) Throttle position sensor Torque converter turbine speed sensor ATF temperature sensor
AWD transfer clutch control	Ordinary transfer control	Throttle position sensor Vehicle speed sensor 1 (rear) Vehicle speed sensor 2 (front) Torque converter turbine speed sensor Inhibitor switch ATF temperature sensor FWD switch
	1st range control	Throttle position sensor Vehicle speed sensor 1 (rear) Vehicle speed sensor 2 (front) Torque converter turbine speed sensor Inhibitor switch
	Slip detection control	Throttle position sensor Vehicle speed sensor 1 (rear) Vehicle speed sensor 2 (front)
	Steering control	Throttle position sensor Vehicle speed sensor 1 (rear) Vehicle speed sensor 2 (front)
	ABS operation control	ABS signal Throttle position sensor Vehicle speed sensor 1 (rear) Vehicle speed sensor 2 (front) Brake switch

### 3-2 [M12B0] MECHANISM AND FUNCTION

#### 12. Transmission Control Module (TCM)

## B: SYSTEM DIAGRAM

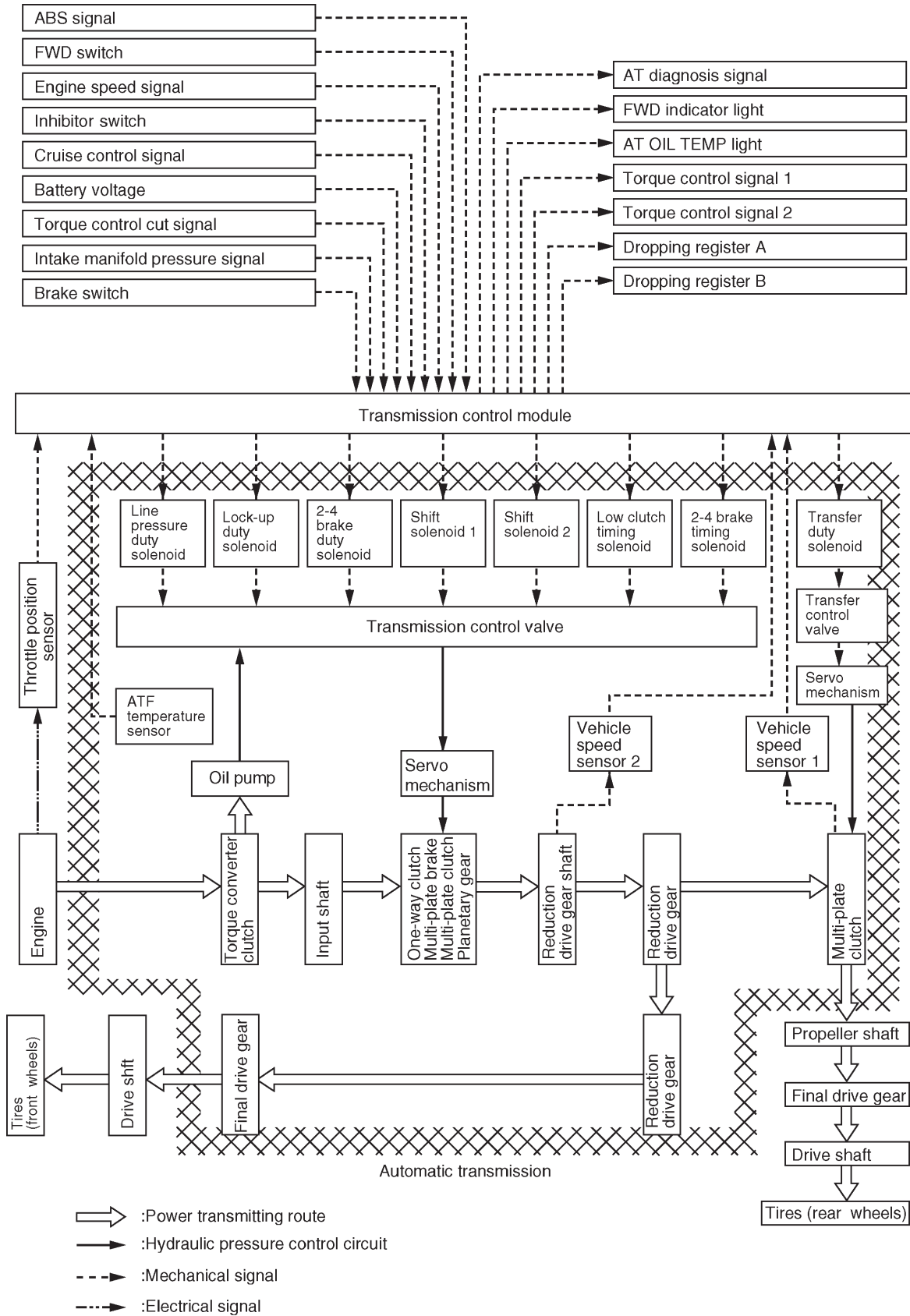

B3H1673A

**C: SHIFT CONTROL**

Gearshifting is controlled in response to driving conditions, according to the shift point characteristic data stored in the TCM. Solenoids are operated at the proper time corresponding to the shift pattern, throttle position, and vehicle speed for smooth shifting.

**NOTE:**

When oil temperature is below approximately 10°C (50°F), the vehicle cannot be shifted to the 4th gear.

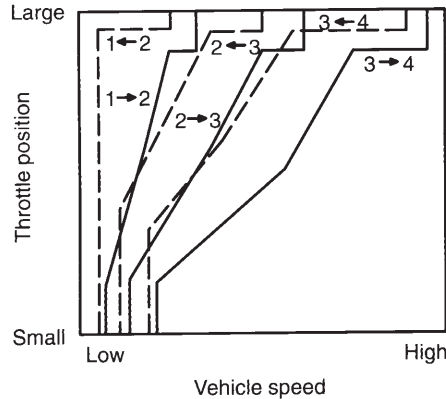

	Solenoid 1	Solenoid 2
1st	ON	ON
2nd	OFF	ON
3rd	OFF	OFF
4th	ON	OFF

G3H0752

- Control module activates both solenoids 1 and 2 in response to throttle and vehicle speed signals.
- Shift valve moves in response to solenoid operation, supplying/interrupting clutch pressure to the line.
- Gears are shifted by ON-OFF operation of both solenoids as indicated in Table.

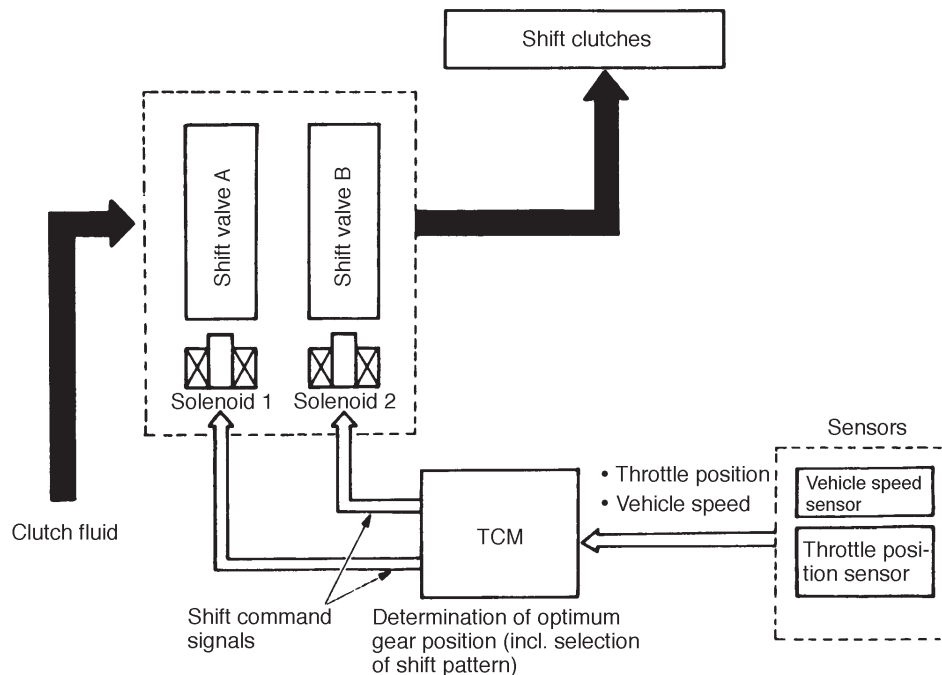

G3H0753

**3-2 [M12D0]****MECHANISM AND FUNCTION****12. Transmission Control Module (TCM)****D: LOCK-UP CONTROL**

The lock-up engaging and disengaging conditions are set for 4th gear shift range, gear position and shift pattern and correspond to the throttle position and vehicle speed, and the duty solenoid electronically controlled by TCM controls the lock-up clutch. The lock-up clutch engagement and disengagement are controlled by the lock-up control valve.

<When engaging and disengaging>

The lock-up control valve engages and disengages the lock-up clutch by adjusting the hydraulic pressure.

**1. NON-LOCK-UP OPERATION**

The transmission control module (TCM) sends output signals to the lock-up duty solenoid. This causes the amount of ATF drained from the lock-up duty solenoid valve to be reduced, which increases the lock-up duty pressure.

The increased lock-up duty pressure moves the lock-up control valve upwards, connecting the torque converter regulator valve to the torque converter control valve release port.

Therefore, the oil pressure from the torque converter regulator valve flows through the lock-up control valve release port to the torque converter clutch and the torque converter apply circuit. As a result, the lock-up piston is forced to separate from the impeller cover, and power is transmitted from impeller to turbine to input shaft, as with an ordinary torque converter clutch coupling.

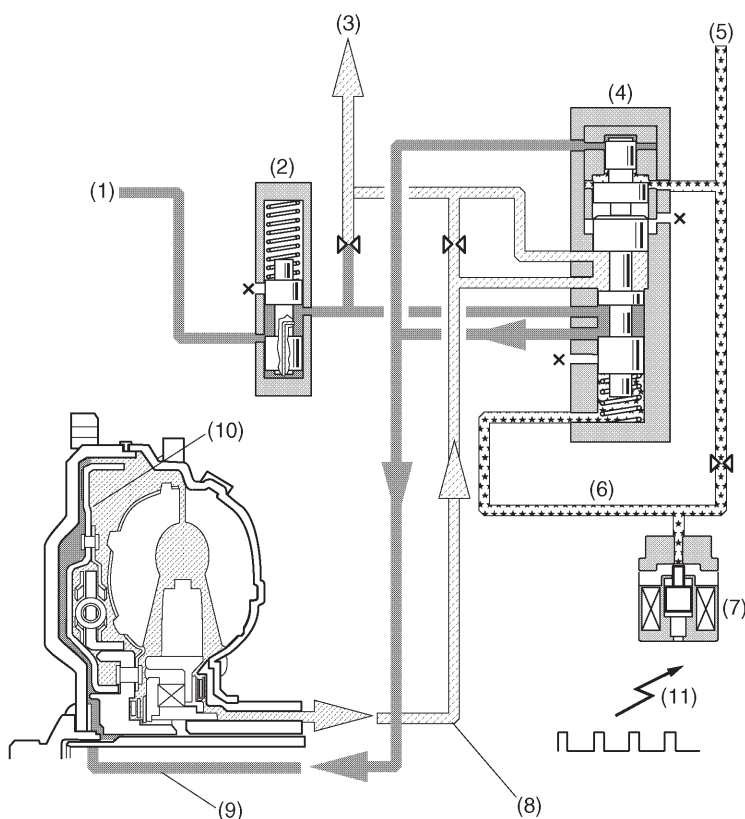

B3H1650A

- |                                      |                           |                             |
|--------------------------------------|---------------------------|-----------------------------|
| (1) From pressure regulator valve    | (5) Pilot pressure        | (9) Lock-up release circuit |
| (2) Torque converter regulator valve | (6) Lock-up duty pressure | (10) Lock-up clutch         |
| (3) To ATF cooler                    | (7) Lock-up duty solenoid | (11) Output signal          |
| (4) Lock-up control valve            | (8) Lock-up apply circuit |                             |

## 2. LOCK-UP OPERATION

The transmission control module (TCM) sends output signal to the lock-up duty solenoid. Since the lock-up duty solenoid operates in proportion to the duty ratio, the amount of ATF drained from there is increased, thus lock-up duty pressure being reduced.

As a result, the lock-up control valve moves downward, which connects the torque converter regulator valve and the lock-up control valve apply port to each other.

In this condition, the oil pressure from the torque converter valve flows through the lock-up control valve apply port to the torque converter and the torque converter clutch. This causes a pressure differential across the lock-up piston. The piston is then forced against the impeller cover and turned as an integral unit with the cover. Thus, power from the engine is directly transmitted to the transmission input shaft. That is, the transmission is directly coupled to the engine.

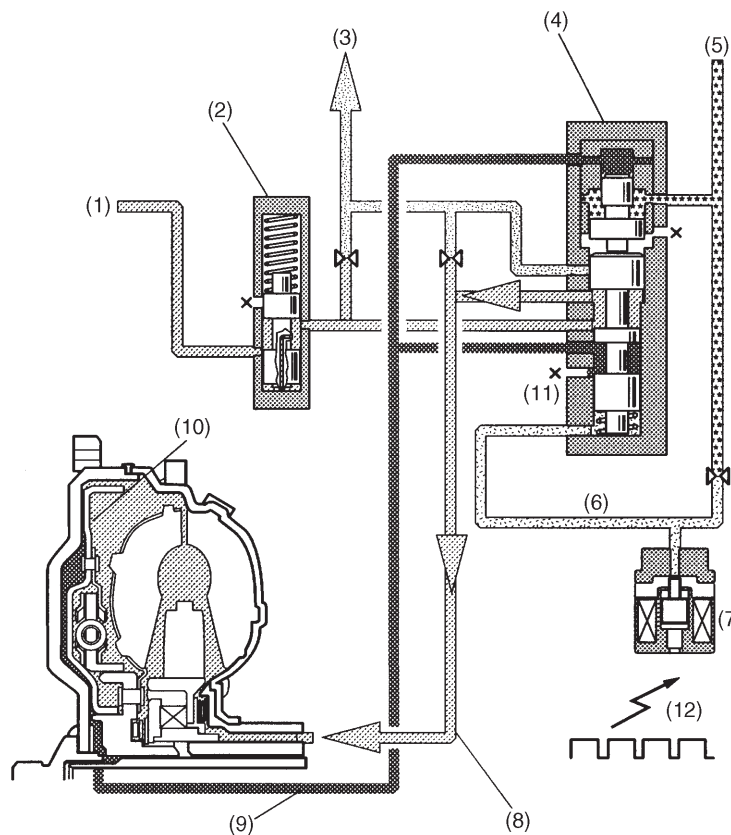

S3H0180A

- |                                      |                           |                             |
|--------------------------------------|---------------------------|-----------------------------|
| (1) From pressure regulator valve    | (5) Pilot pressure        | (9) Lock-up release circuit |
| (2) Torque converter regulator valve | (6) Lock-up duty pressure | (10) Lock-up clutch         |
| (3) To ATF cooler                    | (7) Lock-up duty solenoid | (11) Drain                  |
| (4) Lock-up control valve            | (8) Lock-up apply circuit | (12) Output signal          |

### <Smooth control>

The lock-up duty solenoid is controlled by the TCM and controls the operation of the lock-up control valve. Because the lock-up operating pressure is controlled by the lock-up control valve, the force applied to the lock-up clutch is controlled for smooth clutch operation.

When locking up, the clutch is set in the half-engaged state beforehand. After this, the lock-up operating pressure is gradually increased to achieve smooth locking up.



**F: LINE-PRESSURE SHIFTING CONTROL****1. FUNCTION**

Oil pressure which engages shift clutches (to provide 1st through 4th speeds) is electronically controlled to meet varying operating conditions.

In other words, line pressure decreases to match the selected shift position, minimizing shifting shock.

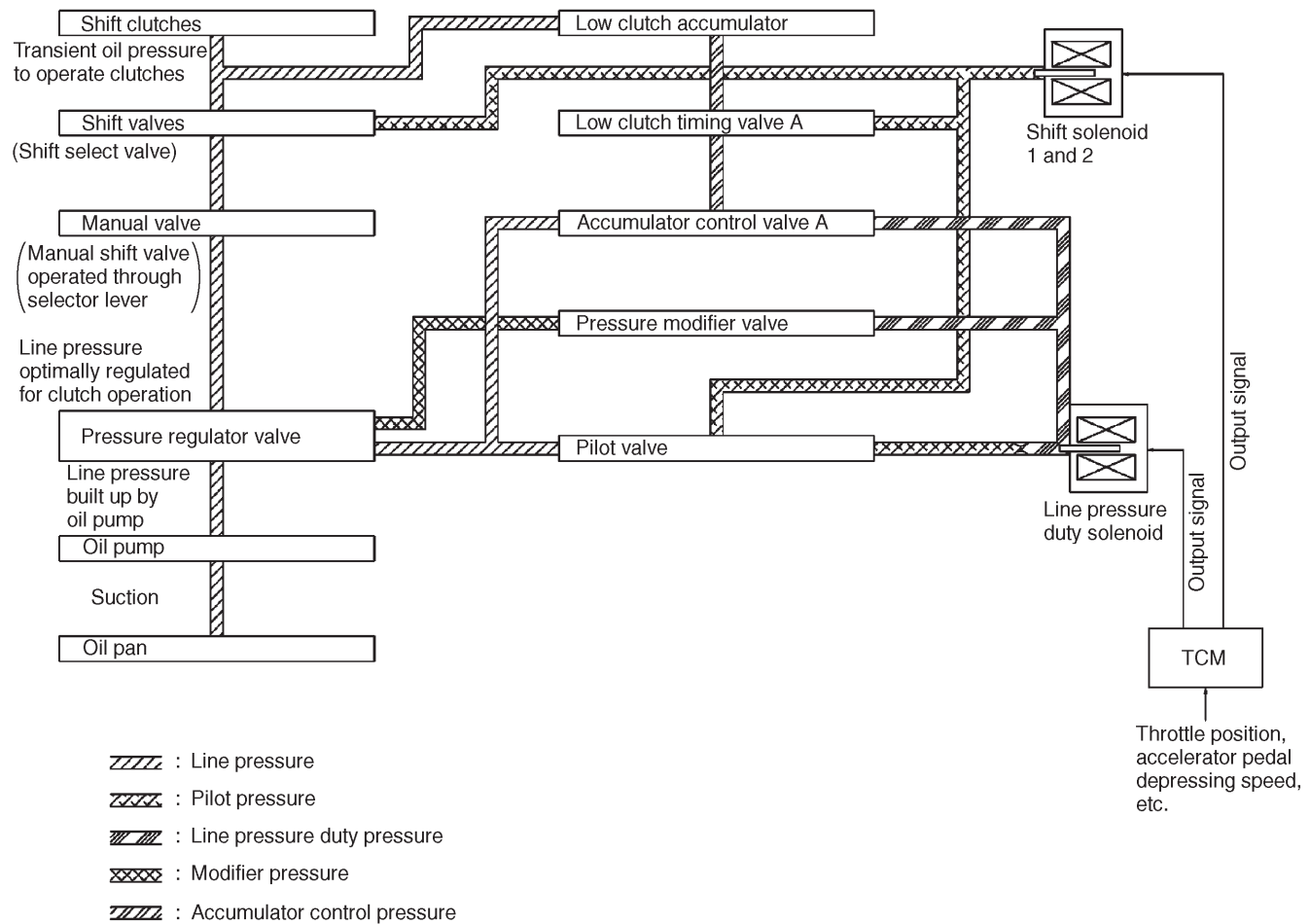

B3H0996B

**2. ELECTRONIC CONTROL OF CLUTCH OIL PRESSURE IN SUMMARY**

- Solenoids activate through the TCM which receives various control signals (throttle signal, etc.)
- Control signals are converted into line pressure duty pressure, which is transmitted to the pressure modifier valve.



**3-2 [M12G0] MECHANISM AND FUNCTION**  
 12. Transmission Control Module (TCM)

**G: SHIFT PATTERN SELECT CONTROL**

Shift pattern is selectable automatically between a base pattern suitable for ordinary economy running and a power pattern suitable for climbing uphill or rapid acceleration.

In the power pattern, the shift down point and shift up point are set higher than those of the base pattern.

Selector position	Changeover from base to power pattern
D, 3 range	Performed automatically corresponding to accelerator pedal depression.

**“D” range (Base pattern)**

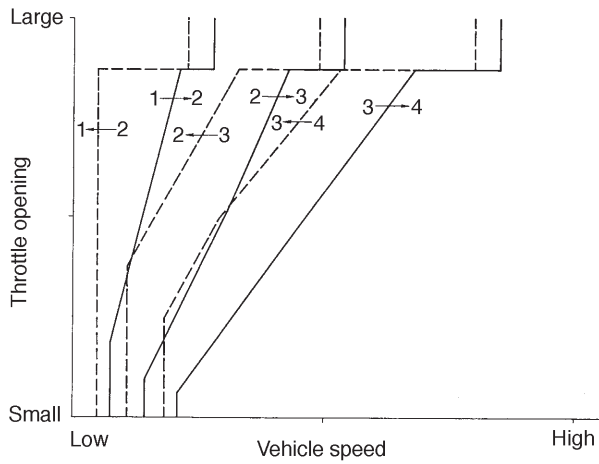

**“D” range (Power pattern)**

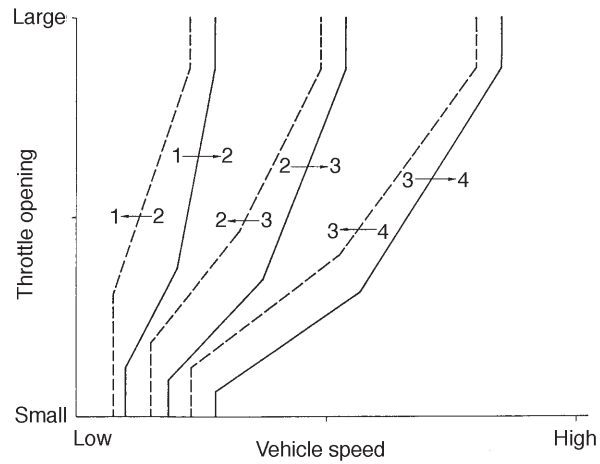

H3H1231A

**MECHANISM AND FUNCTION****[M12G2] 3-2**

12. Transmission Control Module (TCM)

**1. BASE PATTERN TO POWER PATTERN**

Select lever	D, 3 range
Accelerator depression speed	Greater than set value

Depending on throttle opening and vehicle speed, 16 areas as shown in the figure are set. Accelerator depression speed for pattern changeover is set for each area.

When the accelerator depression speed exceeds this set value, the pattern changes from base to power.

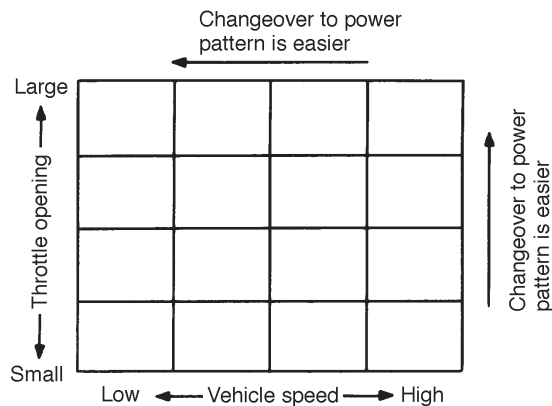

G3H0248

**2. POWER PATTERN TO BASE PATTERN**

The power pattern is shifted to the base pattern, depending on car speed. Shifting to the base pattern is determined by the throttle position as shown in Figure below. Time lag in shifting is also determined by car speed. The maximum time lag is 3 seconds.

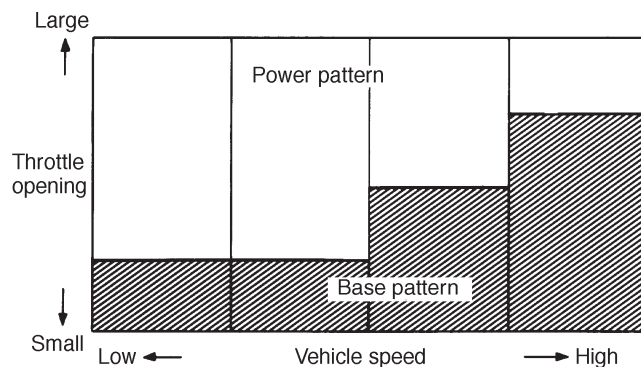

B3H1763A

**3-2 [M12H0]****MECHANISM AND FUNCTION****12. Transmission Control Module (TCM)****H: REVERSE INHIBIT CONTROL**

This control prevents the transmission from shifting into reverse when the select lever is accidentally placed in "R" range, protecting the components such as reverse clutch against damage.

If "R" range is selected during driving at a speed higher than the predetermined, the low clutch timing solenoid is energized.

Then, the pilot pressure is supplied to the reverse inhibit valve. This causes the reverse inhibit valve to move downward, closing the low & reverse brake port.

In this condition, the low & reverse brake does not engage since the ATF flowing from the manual valve is blocked by the reverse inhibit valve.

As a result, the transmission is put into Neutral, and the shifting into reverse is inhibited.

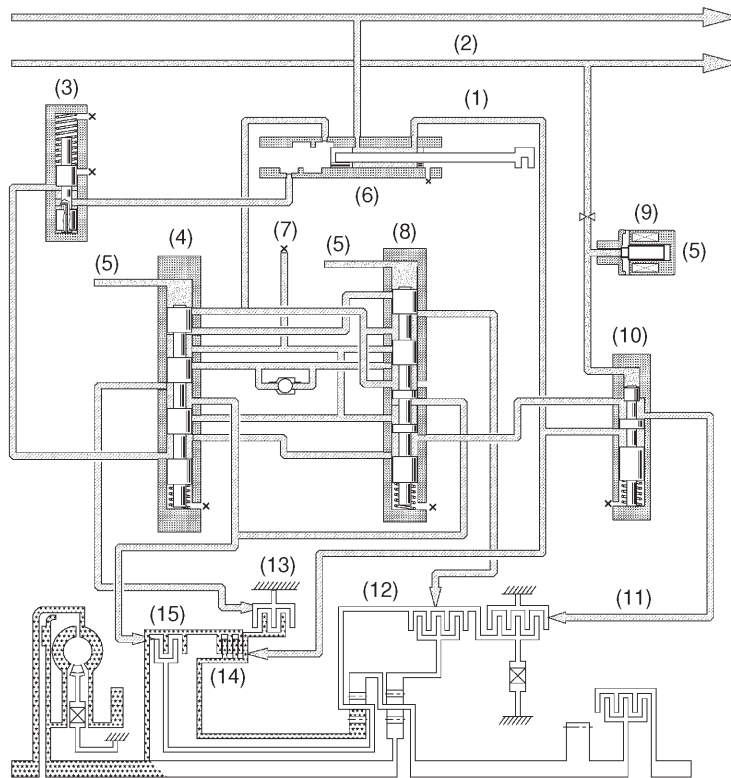

B3H1739A

- |                        |                                |                                    |
|------------------------|--------------------------------|------------------------------------|
| (1) Line pressure      | (6) Manual valve (P range)     | (11) Low & reverse brake (Release) |
| (2) Pilot pressure     | (7) Drain                      | (12) Low clutch                    |
| (3) 1st reducing valve | (8) Shift valve B              | (13) 2-4 brake                     |
| (4) Shift valve A      | (9) Low clutch timing solenoid | (14) Reverse clutch                |
| (5) ON                 | (10) Reverse inhibit valve     | (15) High clutch                   |

# MECHANISM AND FUNCTION

[M1210] 3-2

12. Transmission Control Module (TCM)

## I: GRADE CONTROL

While a vehicle is driving up a hill, gear position is fixed to 3rd gear for avoiding busy up and down shift between 3rd – 4th gears.

When a vehicle is descending a steep hill under the designated vehicle speed (approximately 50 miles/hour), 4th gear downshifts to 3rd gear automatically by depressing the brake pedal.

This gearshift control is released by re-accelerating with depressing the accelerator pedal.

These controls are doing this based on the combination of throttle opening angle, engine speed, vehicle speed and so on.

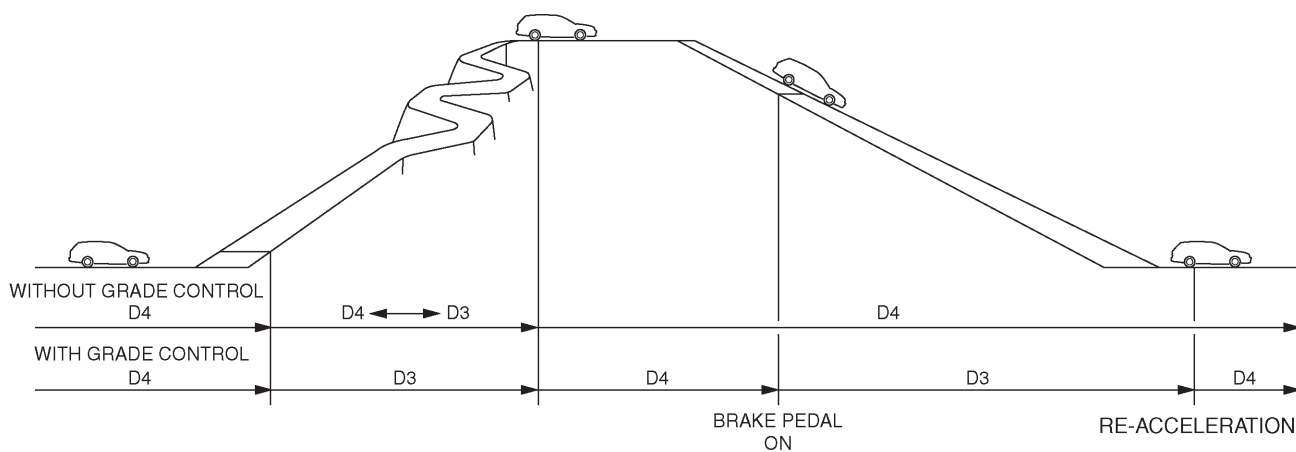

B3H1751A

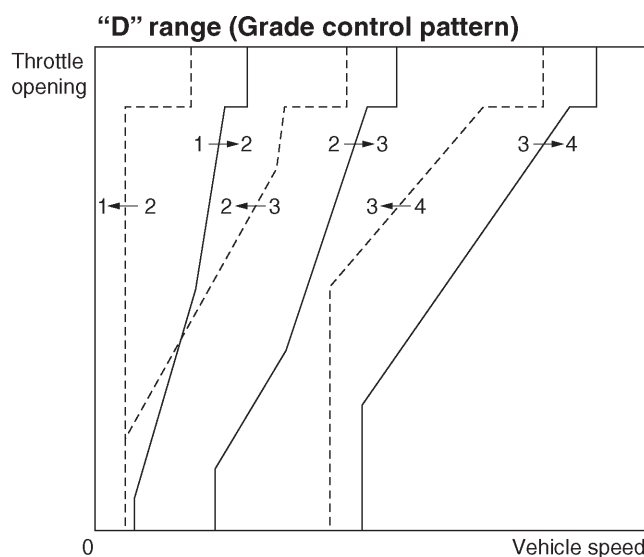
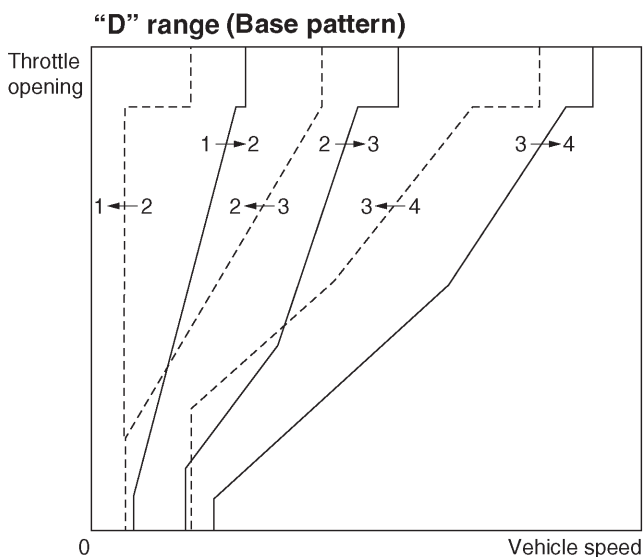

B3H1755A

## **3-2 [M12J0] MECHANISM AND FUNCTION**

### **12. Transmission Control Module (TCM)**

---

#### **J: LEARNING CONTROL**

This transmission is provided with a learning control function which allows the transmission hydraulic pressure to be so controlled that the transmission makes a shift at the optimum shifting point according to the vehicle conditions.

For this reason, there may be cases where shift shocks become larger after the power supply is once interrupted (disconnection of battery terminal, flat battery, etc) or immediately after the ATF is replaced.

Once power supply is interrupted, the hydraulic pressure correction values so far learnt and stored are erased and the system is initialized (reset to the new vehicle conditions).

The system starts the learning again as soon as the power supply is restored, and after driving for a while, the transmission becomes shiftable at the optimum shifting points.

Larger shift shocks immediately after ATF change are caused by the change in friction characteristics of the transmission internal parts.

Also in this case, therefore, the transmission becomes shiftable at the optimum shifting points after driving for a while.

**MECHANISM AND FUNCTION**

**K: AWD TRANSFER CLUTCH CONTROL**

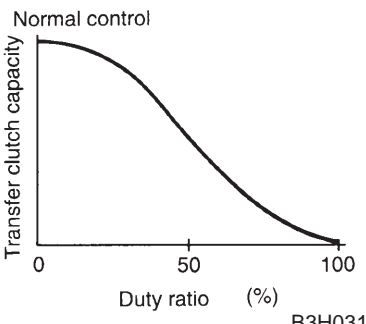
Control item	Type of control	Gear position	Remarks	
1	Basic control	Regulates transfer oil pressure in response to throttle position and vehicle speed.	1st thru 4th and reverse	Normal control  B3H0314
2	Control in 1st range	Increases transfer oil pressure above basic control pressure	1st	-
3	Control during "slip" detection	Increases transfer oil pressure to the same as in 1st range immediately after "slip" detection.	1st thru 4th and reverse	Release: At more than set vehicle speed and fully closed throttle
4	Control in turns	Decreases transfer oil pressure upon detection of vehicle turns.	1st thru 4th and reverse	-
5	Control in ABS operation	Regulates to the specified transfer oil pressure quickly when the ABS signal is input.	1st thru 4th and reverse	-
6	Control in P and N range	Regulates to the specified transfer oil pressure quickly when shifted to the P or N range.	P and N	-

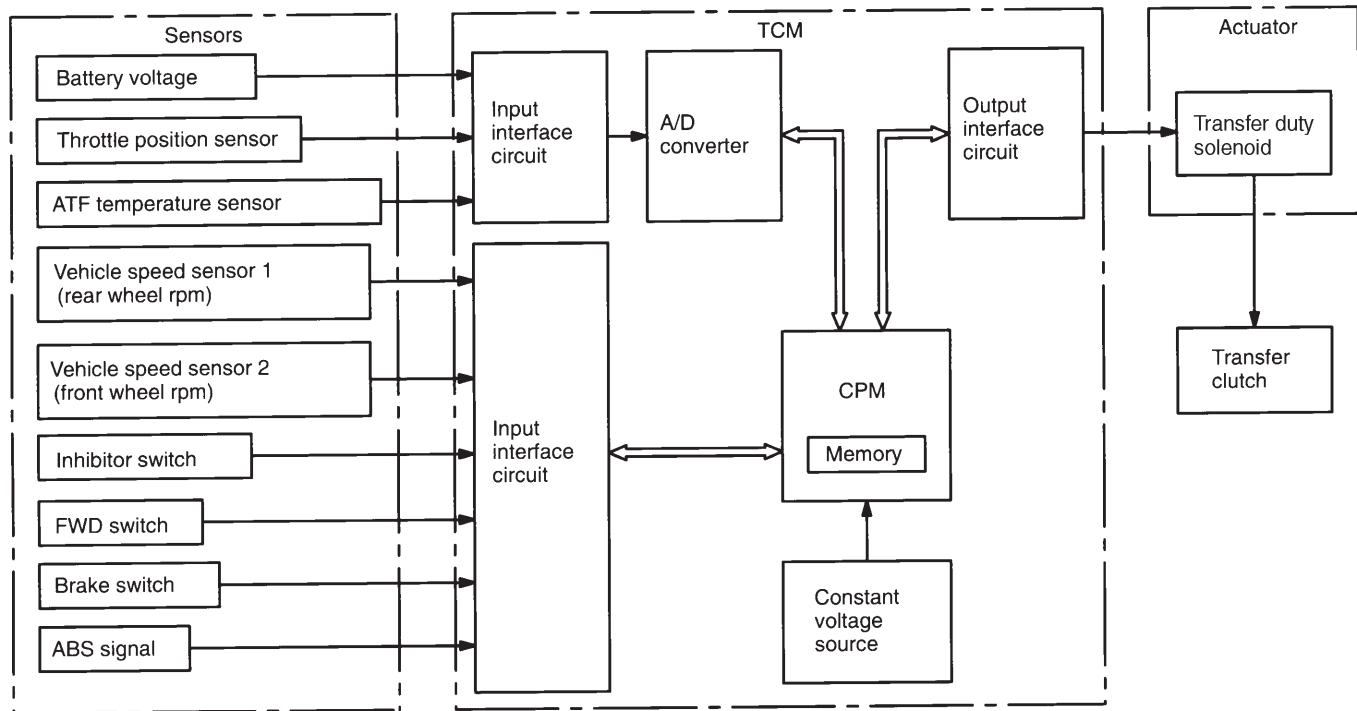

B3H0315A

**3-2 [M12L0]****MECHANISM AND FUNCTION****12. Transmission Control Module (TCM)****L: TRANSFER CONTROL**

The transfer hydraulic pressure control module is fitted with the transfer valve body attached to the rear end face of the transmission case via separate plate.

The hydraulic oil of the transfer hydraulic pressure control module is led from the oil pump delivery pressure circuit on the transmission case front to the transmission case rear. From there it is further fed to the hydraulic circuit of the transfer valve body.

The hydraulic oil pressure (line pressure) is regulated by the transfer duty solenoid and transfer control valve for obtaining optimum rear torque distribution corresponding to the driving conditions.

- The pilot pressure is regulated to the transfer duty pressure by the transfer duty solenoid whose duty ratio is controlled by the TCM corresponding to the driving condition. (The transfer duty pressure varies with the degree of duty control.)
- The transfer duty pressure is applied to the transfer control valve.
- The line pressure is led also to the transfer control valve where the pressure is regulated to the transfer clutch pressure by the transfer duty pressure. (The transfer clutch pressure varies with the transfer duty pressure.)
- The transfer clutch pressure is applied to the transfer clutch and causes the clutch to be engaged.

In this way, the transfer clutch pressure is varied so that optimum rear torque distribution can be achieved which corresponds to the vehicle driving conditions.

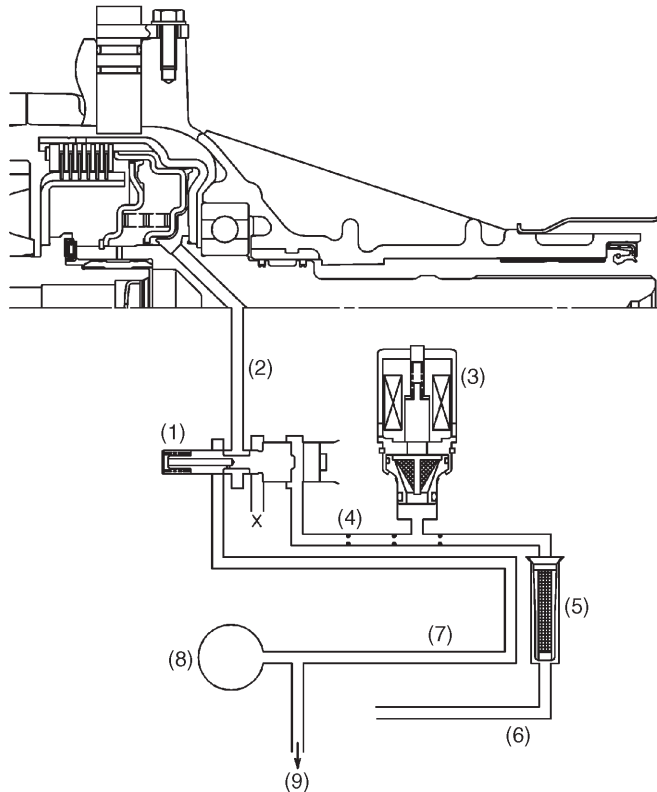

- (1) Transfer control valve  
 (2) Transfer clutch pressure  
 (3) Transfer duty solenoid

- (4) Transfer pressure  
 (5) Filter  
 (6) Pilot pressure

- (7) Line pressure  
 (8) Oil pump  
 (9) Control valve

B3H0912A