

4-3 [M1A0]

1. Tilt Steering Column

MECHANISM AND FUNCTION

1. Tilt Steering Column

A: TILT MECHANISM

- The steering wheel vertical position can easily be adjusted within 35 mm (1.38 in) range, by using the tilt lever to release the steering column and locking it at the desired position.

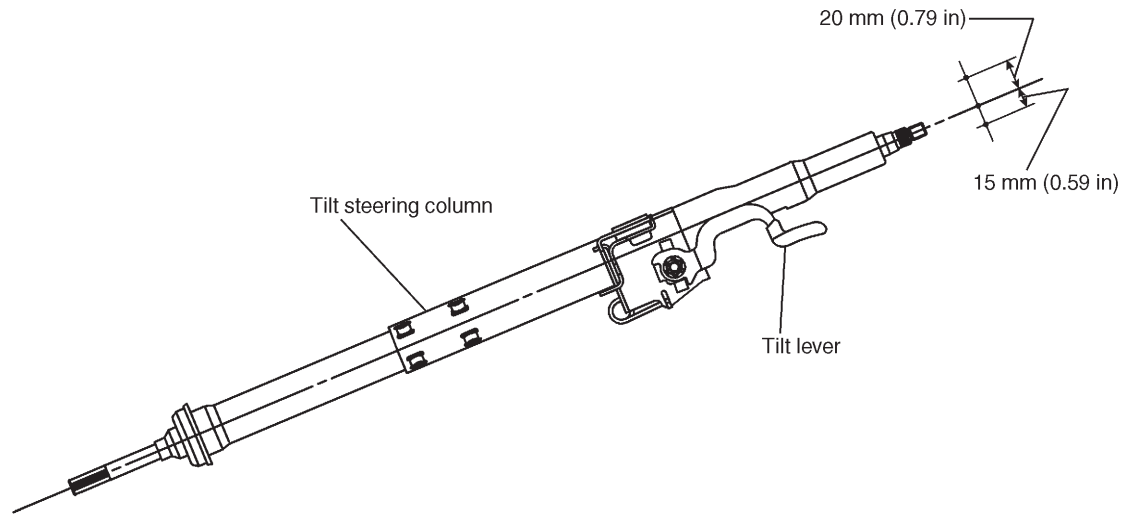

B4H1716A

B: ENERGY-ABSORBING MECHANISM

- To absorb the engine backward energy in the event of a collision, an elliptical fit type column pipe has been adopted. The energy is absorbed by collapse of the elliptical fit portions as their surfaces come in contact with each other and receive the bend load.
- To absorb the energy of shock on the drive in the event of a collision, an ripping plate has been adopted between the tilt bracket to be secured to the steering support beam and the column. The ripping plate is deformed as it is ripped, and continues to stably absorb the energy.

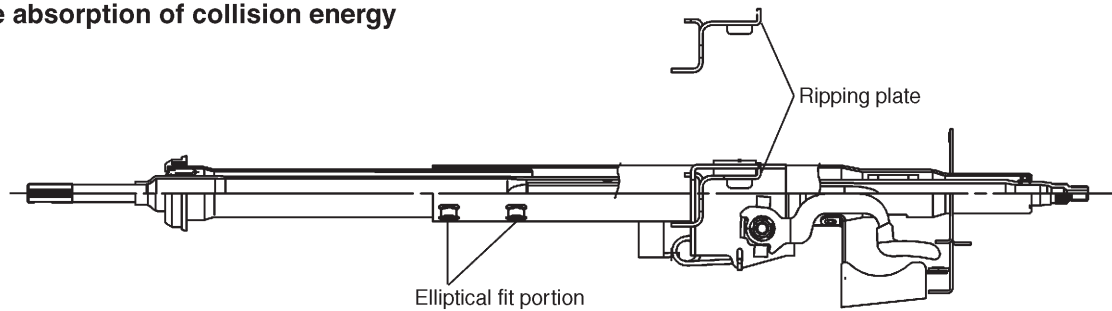
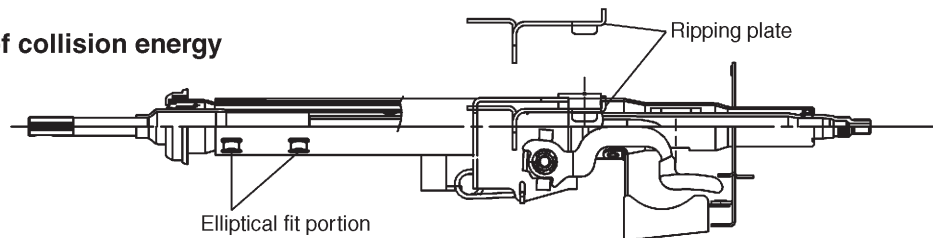
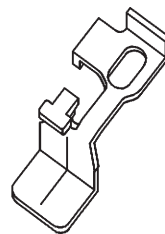
Before absorption of collision energy**After absorption of collision energy****Ripping plate**

Before ripped

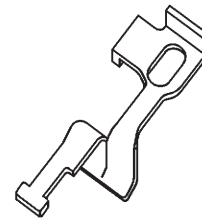

After ripped

B4H1717A

4-3 [M1C0]

1. Tilt Steering Column

MECHANISM AND FUNCTION

C: STEERING SUPPORT BEAM

The steering column is held by a support beam located close to the steering wheel to reduce the overhang. The upper bearing is also located close to the steering wheel to increase supporting rigidity, as well as to reduce the problem of a shaking or shimmying wheel.

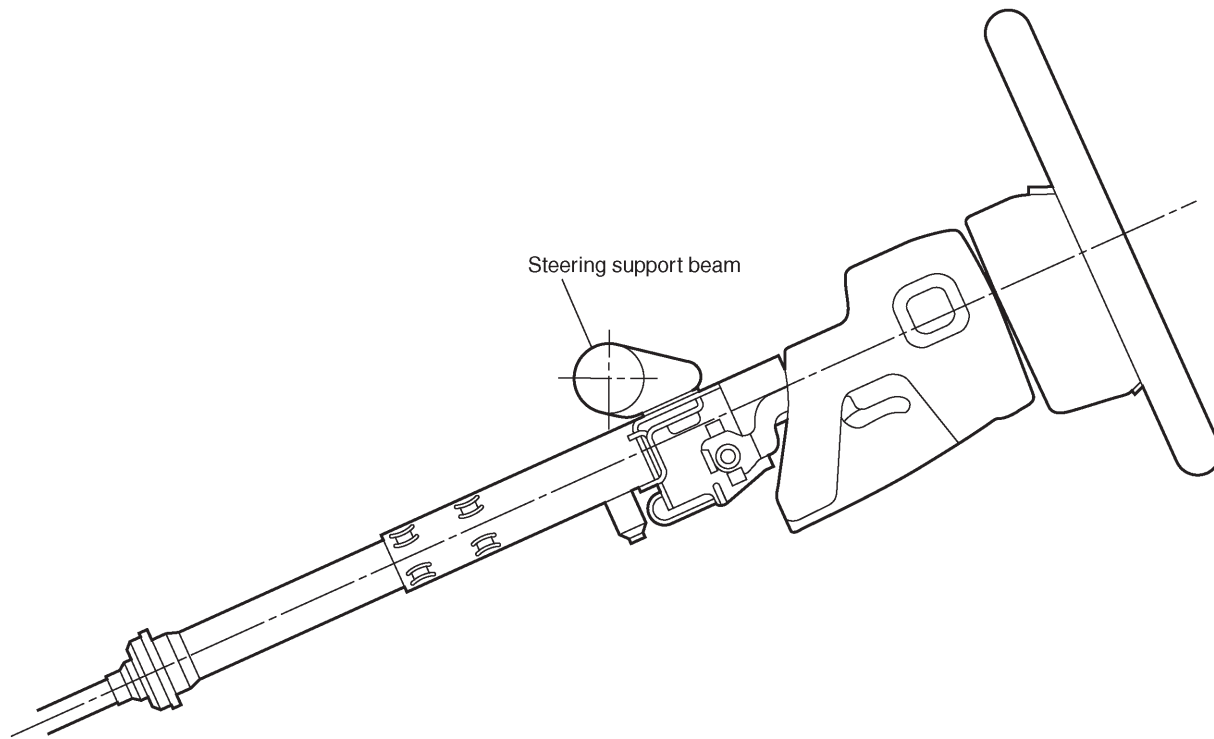

B4H1718A