

TRANSFER CLUTCH

Automatic Transmission

10. Transfer Clutch S510588

A: REMOVAL S510588A18

- 1) Remove rear vehicle speed sensor.

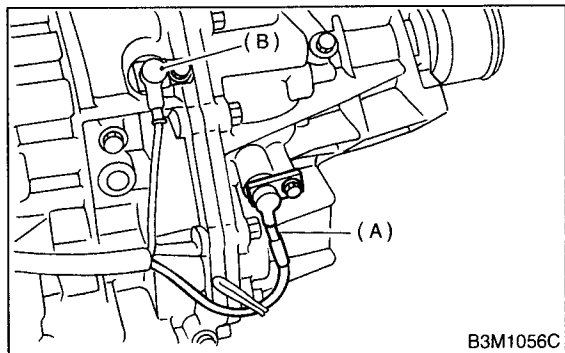

- (A) Rear vehicle speed sensor
- (B) Front vehicle speed sensor

- 2) Separate transmission case and extension case sections.

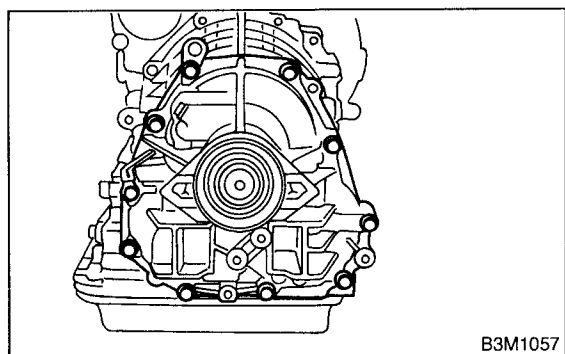

- 3) Take out the transfer clutch by lightly tapping the end of the rear drive shaft.

CAUTION:
Be careful not to damage the oil seal in the extension.

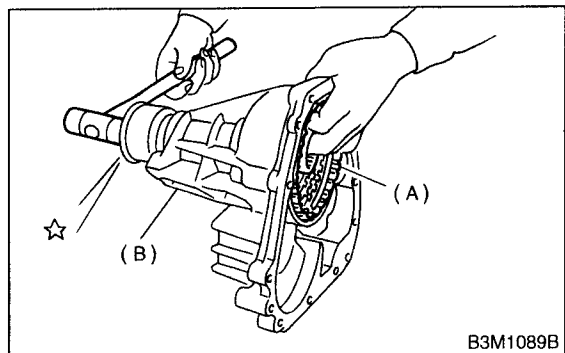

- (A) Transfer clutch
- (B) Extension case

B: INSTALLATION S510588A11

- 1) Install the transfer clutch assembly to the case.

CAUTION:
Be careful not to damage the seal rings.

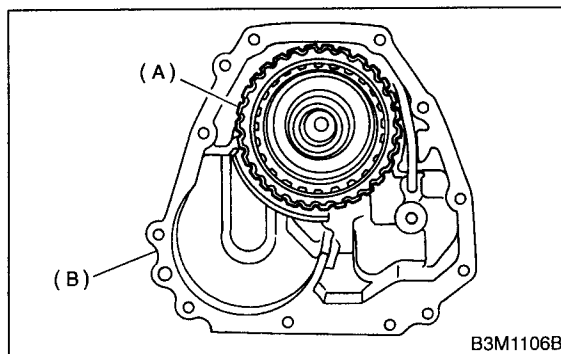

- (A) Transfer clutch
- (B) Extension case

- 2) Tighten bolts to secure the case.

Tightening torque:
25 N·m (2.5 kgf·m, 18.1 ft·lb)

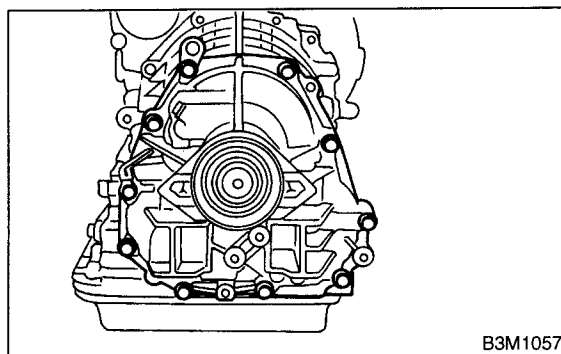

C: DISASSEMBLY S510588A06

- 1) Remove the seal ring.

CAUTION:
Be careful not to damage the seal ring.

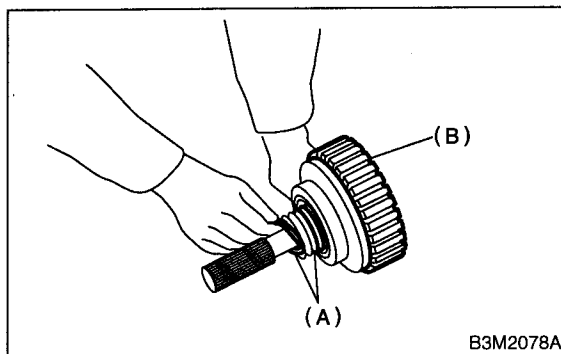

- (A) Seal ring
- (B) Transfer clutch

TRANSFER CLUTCH

Automatic Transmission

2) Using a press and ST, remove the ball bearing.

CAUTION:

Do not reuse the bearing.

ST 498077600 REMOVER

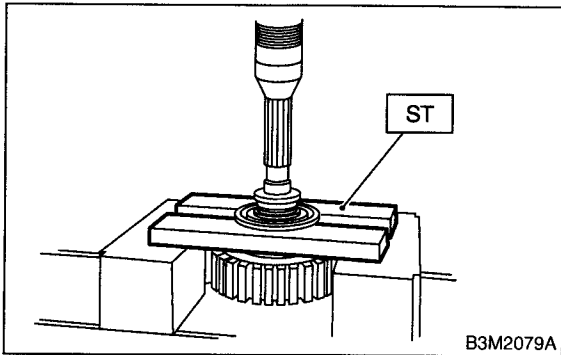

3) Remove the snap ring, and take out the pressure plate, drive plates, and driven plates.

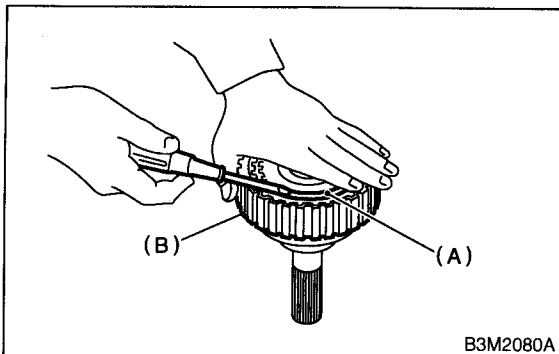

- (A) Snap ring
- (B) Transfer clutch

4) Remove the snap ring with ST1, ST2 and ST3, and take out the return spring and transfer clutch piston seal.

ST1 399893600 PLIERS
ST2 398673600 COMPRESSOR
ST3 398623600 SEAT

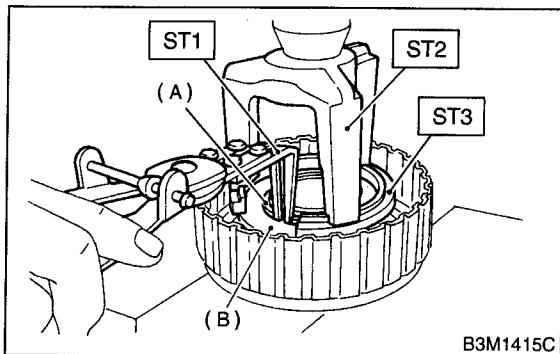

- (A) Snap ring
- (B) Return spring

5) Apply compressed air to the rear drive shaft to remove the piston.

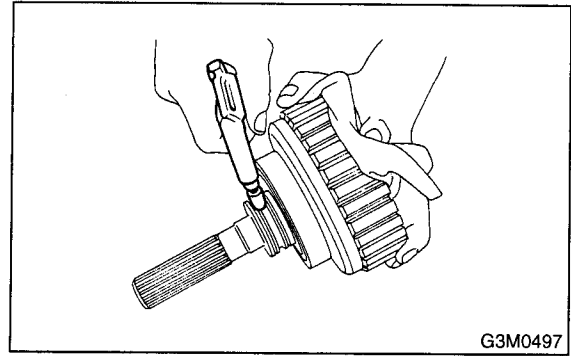

D: ASSEMBLY SS10588A02

1) Install the transfer clutch piston.

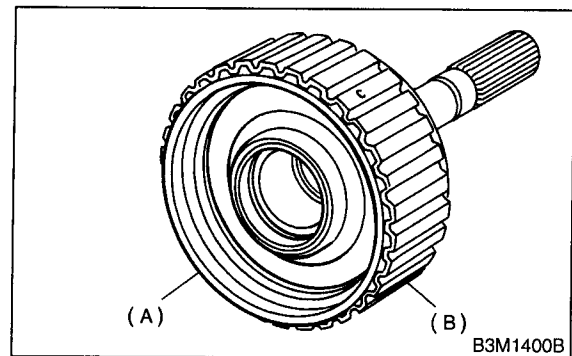

- (A) Transfer clutch piston
- (B) Transfer clutch

2) Install return spring to transfer piston.

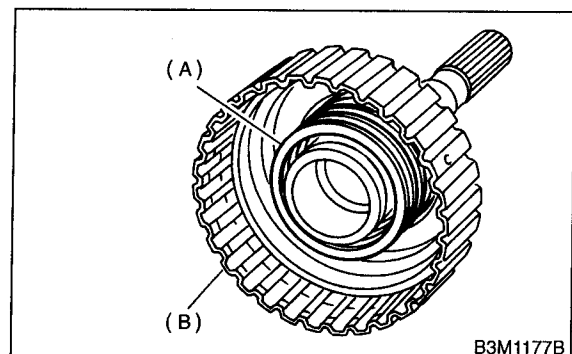

- (A) Return spring
- (B) Transfer clutch

TRANSFER CLUTCH

Automatic Transmission

3) Install transfer clutch piston seal.

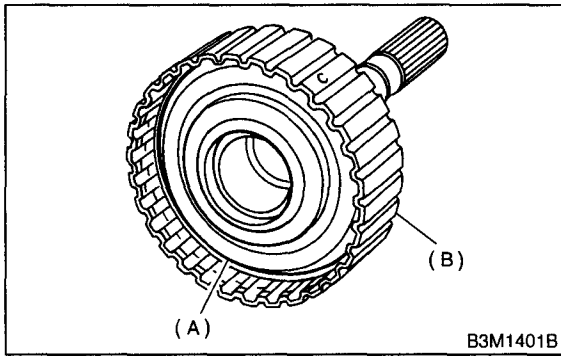

4) Install ST to rear drive shaft.
ST 499257300 SNAP RING OUTER GUIDE

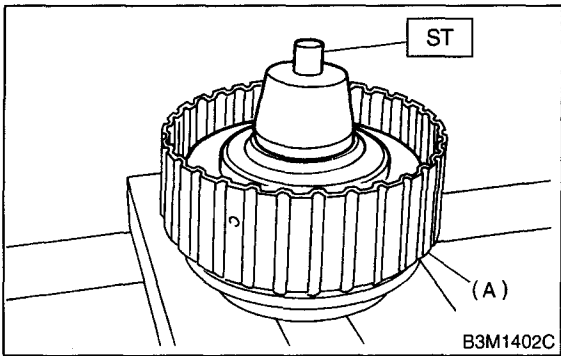

5) Install snap ring to ST.
ST 499257300 SNAP RING OUTER GUIDE

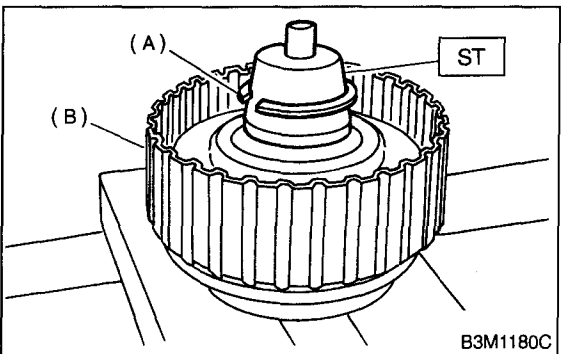

6) Using ST1 and ST2, install snap ring to rear drive shaft.

NOTE:

After installing snap ring, remove ST1 and ST2.

ST1 499257300 SNAP RING OUTER GUIDE

ST2 499247400 INSTALLER

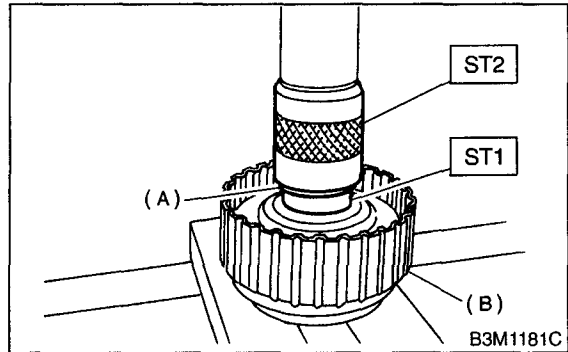

7) Install the driven plates, drive plates, pressure plate and snap ring.

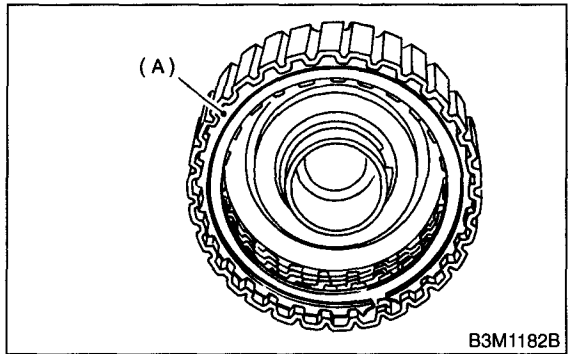

8) Apply compressed air to see if the assembled parts move smoothly.

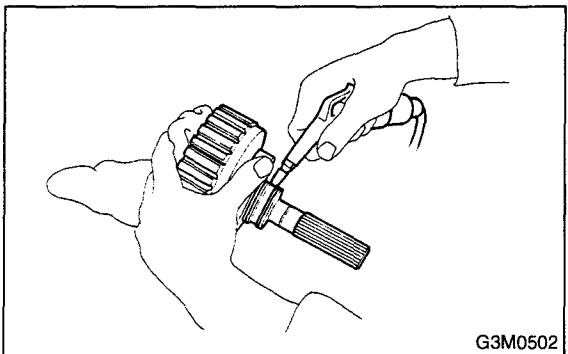

9) Check the clearance.

NOTE:

- Before measuring clearance, place the same thickness of shim on both sides to prevent pressure plate from tilting.
- If the clearance is not within specification, adjust it by selecting a suitable pressure plate on the transfer clutch piston side.

Standard value:

0.7 — 1.1 mm (0.028 — 0.043 in)

Allowable limit:

1.6 mm (0.063 in)

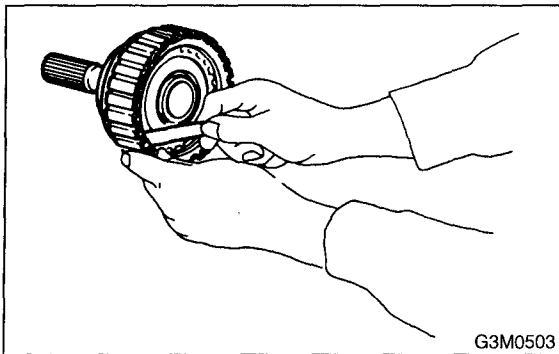

Available pressure plates	
Part No.	Thickness mm (in)
31593AA151	3.3 (0.130)
31593AA161	3.7 (0.146)
31593AA171	4.1 (0.161)
31593AA181	4.5 (0.177)

10) Press-fit the ball bearing with ST.
ST 899580100 INSTALLER

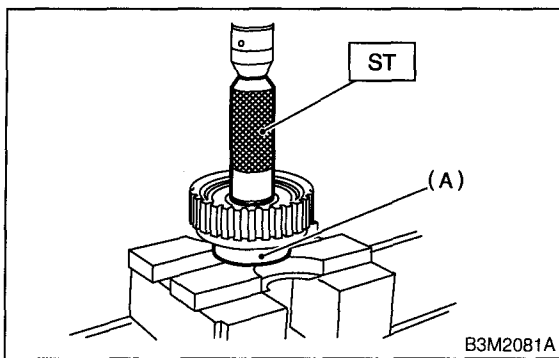

(A) Ball bearing

11) Coat the seal ring with vaseline, and install it in the seal ring groove of the shaft.

CAUTION:

Do not expand the seal ring excessively when installing.

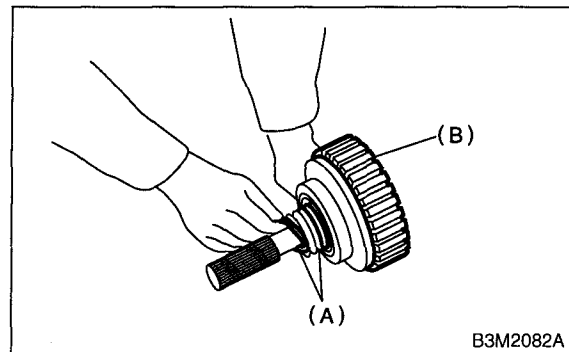

(A) Seal rings
(B) Transfer clutch

12) Install the transfer clutch assembly to the case.

CAUTION:

Be careful not to damage the seal rings.

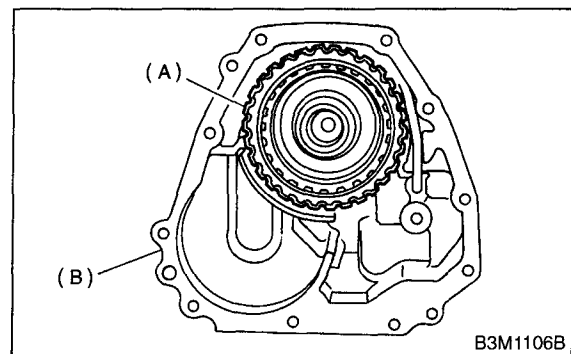

(A) Transfer clutch
(B) Extension case

E: INSPECTION S510588A10

- Check the drive plate facing for wear and damage.
- Check the snap ring for wear, return spring for permanent set and breakage, and return spring for deformation.
- Check the lathe cut ring for damage.
- Measure the extension end play and adjust it to within specifications.

WITHOUT VTD <Ref. to AT-44 WITHOUT VTD, ADJUSTMENT, Transfer Clutch.>

WITH VTD <Ref. to AT-44 WITH VTD, ADJUSTMENT, Transfer Clutch.>

TRANSFER CLUTCH

Automatic Transmission

F: ADJUSTMENT

S510588A01

1. WITHOUT VTD

S510588A0101

1) Measure distance L from end of extension case and rear drive shaft with ST.

ST 398643600 GAUGE

L = Measured value - 15 mm

(L = Measured value - 0.59 in)

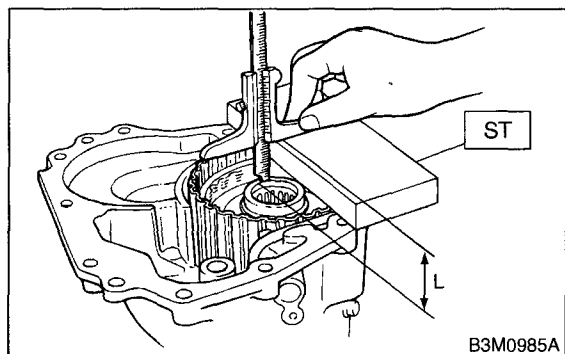

2) Measure the distance "ℓ" from the transmission case mating surface to the reduction drive gear end surface with ST1 and ST2.

ℓ = Measured value - 50 mm

(ℓ = Measured value - 1.97 in)

ST1 398643600 GAUGE

ST2 499577000 GAUGE

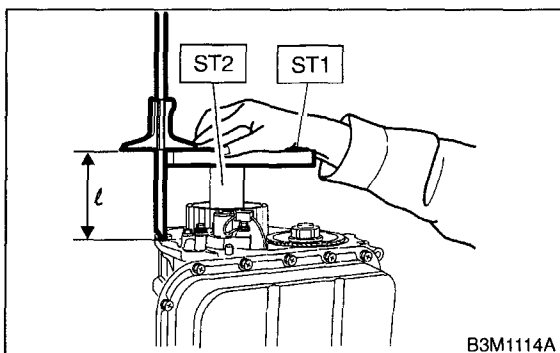

3) Calculation equation:

NOTE:

Add 0.05 mm (0.0020 in) and 0.25 mm (0.0098 in) thick shims to area "T". Calculate formula 2 to determine "H". The calculated "H" refers to the shim thickness range. Select shims of suitable thicknesses within the calculated "H" range.

$$T = (L + G) - \ell - H$$

T: Shim clearance

L: Distance from end of extension case to end of rear drive shaft

G: Gasket thickness [0.45 mm (0.0177 in)]

ℓ: Height from end of transmission case to end of reduction drive gear

H: Thrust needle bearing thickness

0.05 — 0.25 mm (0.0020 — 0.0098 in)

Thrust needle bearing	
Part No.	Thickness mm (in)
806536020	3.8 (0.150)
806535030	4.0 (0.157)
806535040	4.2 (0.165)
806535050	4.4 (0.173)
806535060	4.6 (0.181)
806535070	4.8 (0.189)
806535090	5.0 (0.197)

2. WITH VTD

S510588A0102

1) Install the rear drive shaft into the reduction drive gear and center differential assembly.

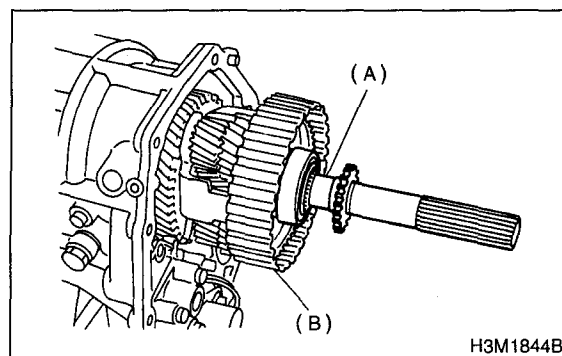

(A) Rear drive plate

(B) Center differential carrier

2) Measure the distance "ℓ" from the transmission case mating surface to the reduction drive gear end surface with ST.

ℓ = Measured value - 50 mm

(ℓ = Measured value - 1.97 in)

ST 398643600 GAUGE

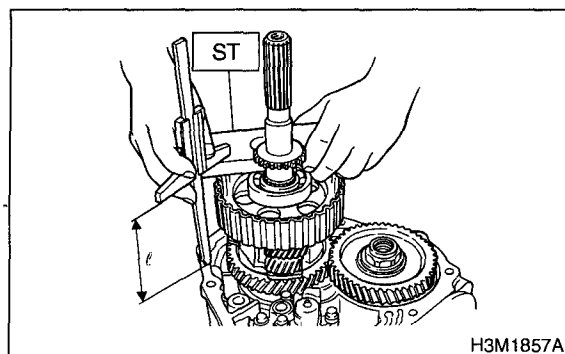

3) Calculation equation:

NOTE:

Add 0.05 mm (0.0020 in) and 0.20 mm (0.0079 in) thick shims to area "T". Calculate formula 2 to determine "H". The calculated "H" refers to the shim thickness range. Select shims of suitable thicknesses within the calculated "H" range.

(0 to 4 teeth)

$$T = (L + G) - \ell - H$$

T: Shim clearance

L: Distance from end of extension case to end of rear drive shaft

G: Gasket thickness [0.45 mm (0.0177 in)]

ℓ : Height from end of transmission case to end of reduction drive gear

H: Shim thickness

0.05 — 0.25 mm (0.0020 — 0.0098 in)

Adjusting shim	
Part No.	Thickness
3281AA001	0.2
3281AA011	0.5