

25. 2-4 Brake S510205

A: REMOVAL S510205A18

- 1) Extract the torque converter clutch assembly. <Ref. to AT-34 REMOVAL, Torque Converter Clutch Assembly.>
- 2) Remove the input shaft.

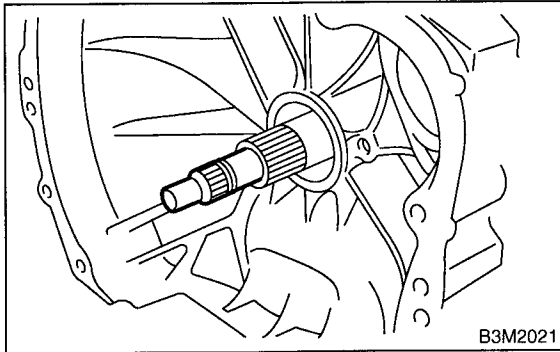

- 3) Disconnect transmission harness connector from stay.

NOTE:

Lift-up lever behind the connector and disconnect it from stay.

- 4) Disconnect inhibitor switch connector from stay.
- 5) Disconnect the air breather hose. <Ref. to AT-27 REMOVAL, Air Breather Hose.>
- 6) Remove the oil charger pipe. <Ref. to AT-28 REMOVAL, Oil Charger Pipe.>
- 7) Remove the oil cooler inlet and outlet pipes with washers. <Ref. to AT-29 REMOVAL, Oil Cooler Pipes.>
- 8) Remove rear vehicle speed sensor, and separate the transmission case and extension case. <Ref. to AT-36 REMOVAL, Extension Case.>
- 9) Remove reduction driven gear. WITHOUT VTD <Ref. to AT-48 WITHOUT VTD, REMOVAL, Reduction Driven Gear.> WITH VTD <Ref. to AT-48 WITH VTD, REMOVAL, Reduction Driven Gear.>
- 10) Separation of torque converter clutch case and transmission case sections

CAUTION:

- Be careful not to damage the oil seal and bushing inside the torque converter clutch case by the oil pump cover.
- Be careful not to lose the rubber seal.

NOTE:

Separate these cases while tapping lightly on the housing.

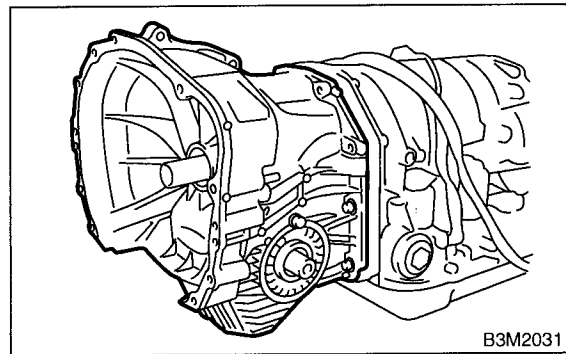

- 11) Place two wooden blocks on the workbench, and stand the transmission case with its rear end facing down.

CAUTION:

- Be careful not to scratch the rear mating surface of the transmission case.
- Note that the parking rod and drive pinion protrude from the mating surface.

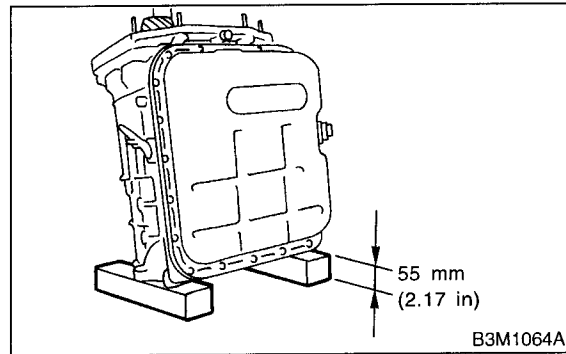

- 12) Remove the oil pan and control valve body. <Ref. to AT-83 REMOVAL, Control Valve Body.>
- 13) Remove the oil pump housing.

CAUTION:

Be careful not to lose the total end play adjusting thrust washer.

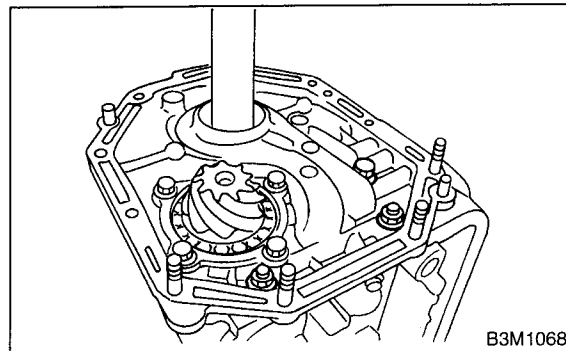

14) Remove 2-4 brake seal.

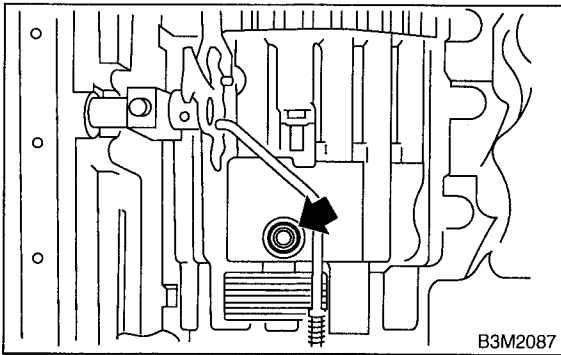

18) Remove snap ring and thrust needle bearing.

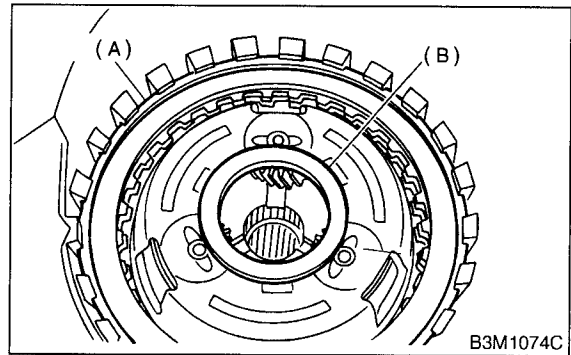

- (A) Snap ring
- (B) Thrust needle bearing

15) Take out the high clutch and reverse clutch assembly. <Ref. to AT-89 REMOVAL, High Clutch and Reverse Clutch.>

16) Take out the front sun gear and the thrust bearing.

19) Take out retaining plate, drive plate and driven plate of 2-4 brake.

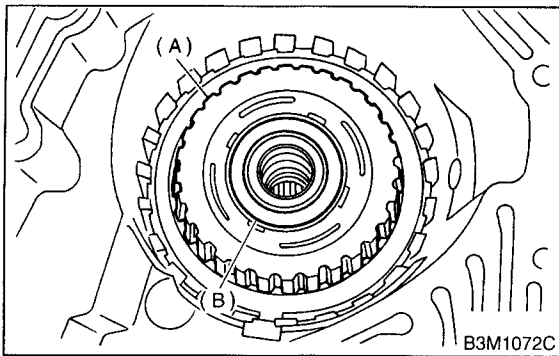

- (A) Front sun gear
- (B) Thrust bearing

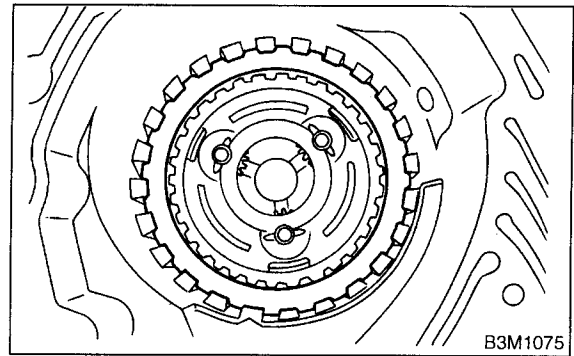

20) Take out the thrust needle bearing, planetary gear assembly and the low clutch assembly.

17) Pull out leaf spring.

CAUTION:

Be careful not to bend leaf spring during removal.

NOTE:

Remove it while pressing down on lower leaf spring.

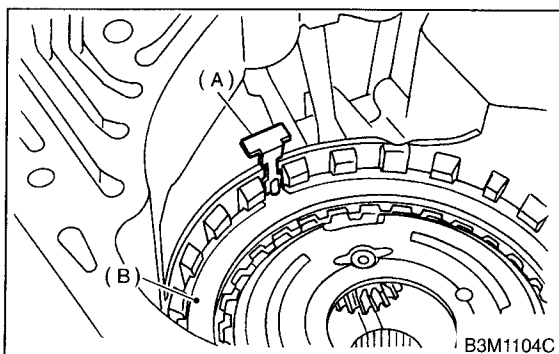
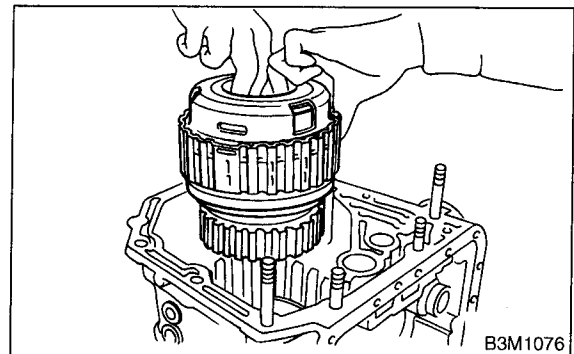

- (A) Leaf spring
- (B) Retaining plate

2-4 BRAKE

Automatic Transmission

21) Remove snap ring.

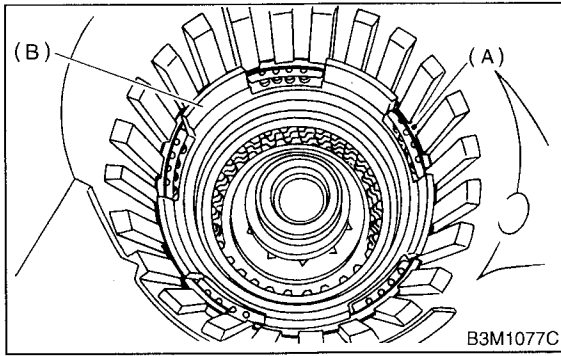

- (A) Snap ring
- (B) 2-4 brake piston

24) Separate 2-4 brake piston and piston retainer.

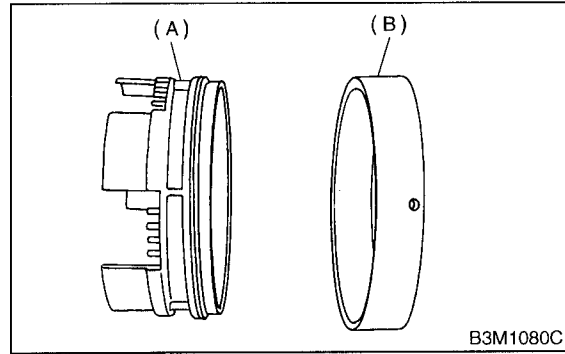

- (A) 2-4 brake piston
- (B) 2-4 brake piston retainer

22) Take out 2-4 brake return spring.

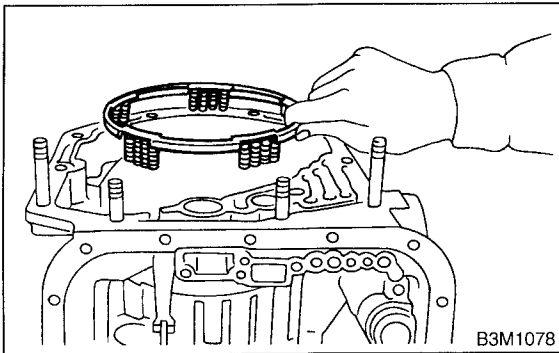

23) Take out 2-4 brake piston and piston retainer.

CAUTION:

When removing the brake piston 2-4 and piston retainer, be careful not to rub or bump them against the transmission case.

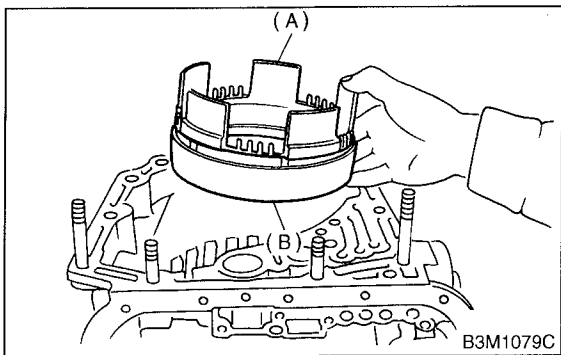

- (A) 2-4 brake piston
- (B) 2-4 brake piston retainer

B: INSTALLATION S510205A11

1) Install 2-4 brake piston to 2-4 brake piston retainer.

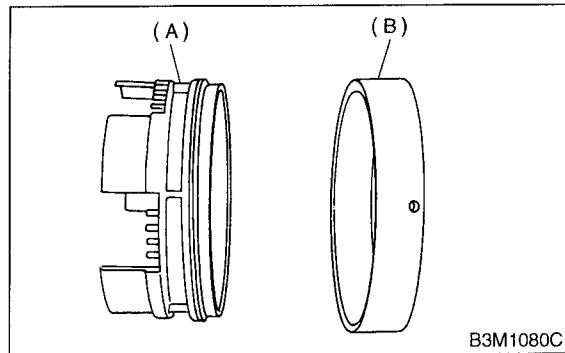

- (A) 2-4 brake piston
- (B) 2-4 brake retainer

2) Install 2-4 brake piston and retainer to transmission case.

CAUTION:

Align the hole in the 2-4 brake seal of transmission case with the hole in 2-4 brake piston retainer during installation.

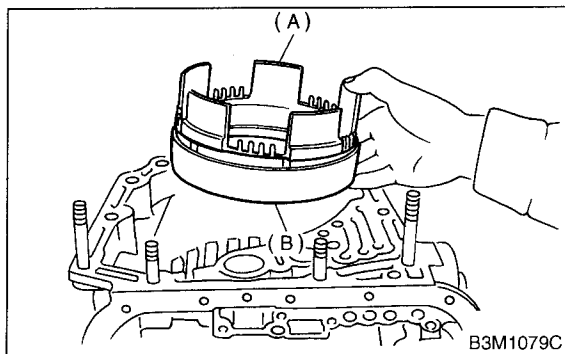

- (A) 2-4 brake piston
- (B) 2-4 brake piston retainer

3) Install 2-4 brake piston return spring to transmission case.

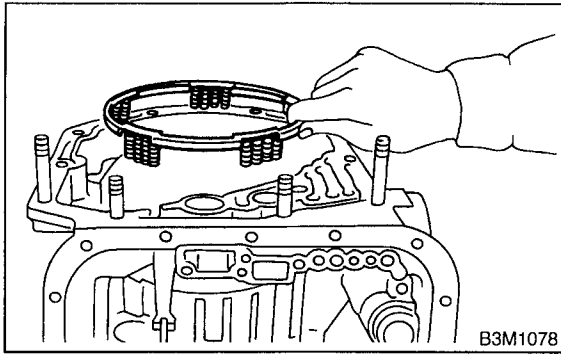

4) Position snap ring in transmission. Using ST, press the snap ring into place.
ST 498677100 COMPRESSOR

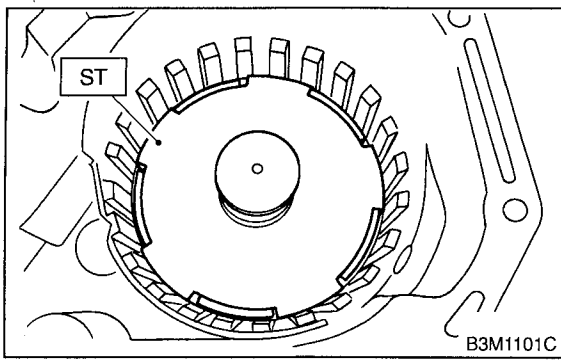

5) Install planetary gear and low clutch assembly to transmission case.

Install carefully while rotating the low clutch and planetary gear assembly slowly paying special attention not to damage the seal ring. <Ref. to AT-96 INSTALLATION, Planetary Gear and Low Clutch.>

6) Install pressure plate, drive plate, driven plate, retaining plate and snap ring.

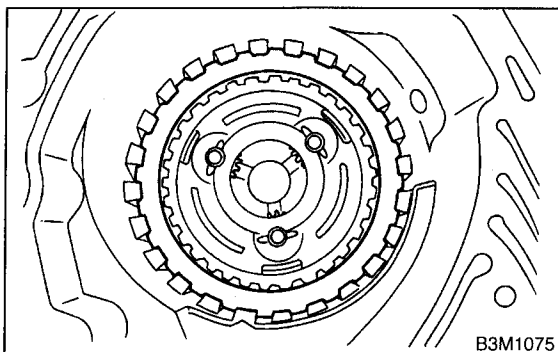

7) Install 2-4 brake oil seal to transmission case.

NOTE:
Be sure to use a new one.

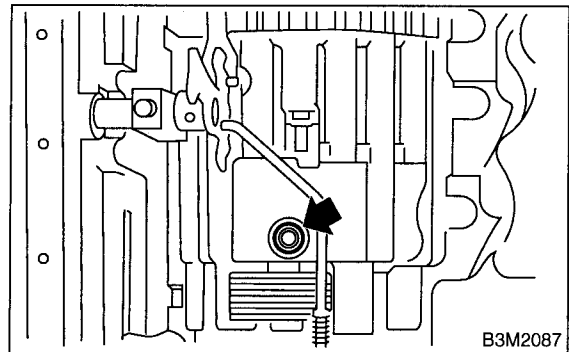

8) After all 2-4 brake component parts have been installed, blow in air intermittently and confirm the operation of the brake.

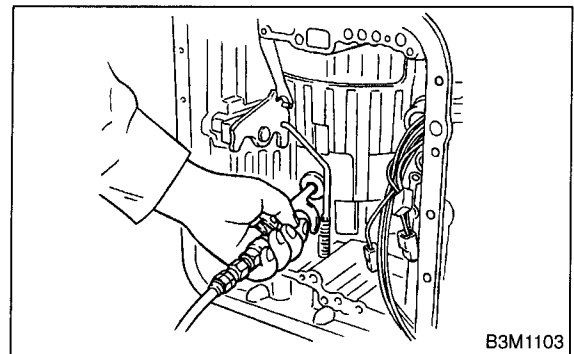

2-4 BRAKE

Automatic Transmission

9) Measure the clearance between the retaining plate and the snap ring.

NOTE:

Select a retaining plate with a suitable value from the following table, so that the clearance becomes the standard value.

Standard value:

0.8 — 1.2 mm (0.031 — 0.047 in)

Allowable limit:

1.5 mm (0.059 in)

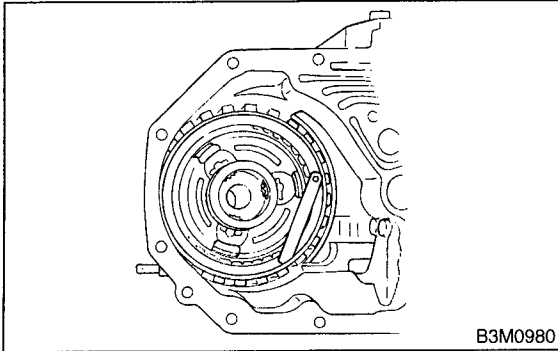

Available retaining plates	
Part No.	Thickness mm (in)
31567AA610	5.6 (0.220)
31567AA620	5.8 (0.228)
31567AA630	6.0 (0.236)
31567AA640	6.2 (0.244)
31567AA650	6.4 (0.252)
31567AA660	6.6 (0.260)

10) Install leaf spring of 2-4 brake.

NOTE:

Be careful not to mistake the location of the leaf spring to be inserted.

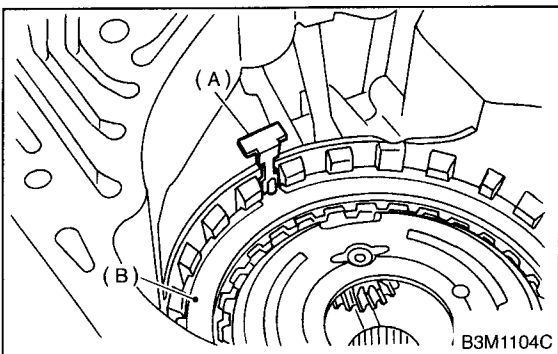

- (A) Leaf spring
- (B) Retaining plate

11) Install thrust needle bearing.

NOTE:

Install thrust needle bearing in the correct direction.

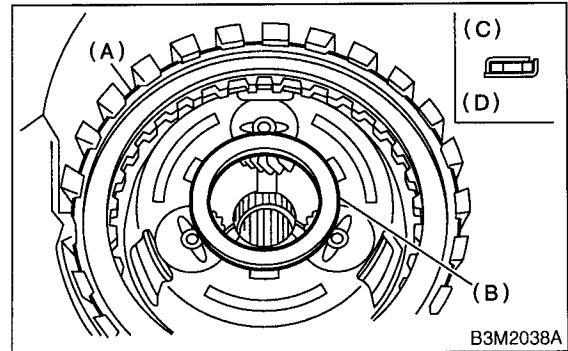

- (A) Snap ring
- (B) Thrust needle bearing
- (C) Up side
- (D) Down side

12) Install front sun gear and thrust needle bearing.

NOTE:

Install thrust needle bearing in the correct direction.

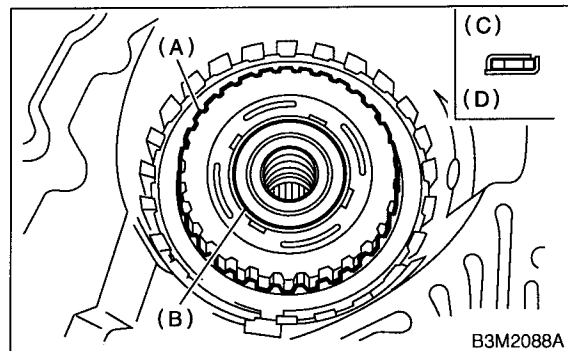

- (A) Front sun gear
- (B) Thrust needle bearing
- (C) Up side
- (D) Down side

13) Install the high clutch assembly. <Ref. to AT-90 INSTALLATION, High Clutch and Reverse Clutch.>

14) Secure the housing with two nuts.

Tightening torque:

T: 41 N·m (4.2 kgf-m, 30.4 ft-lb)

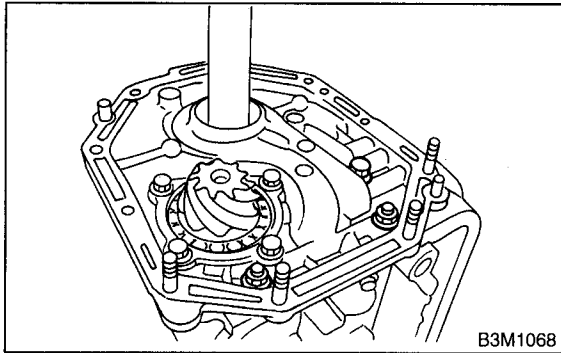

CAUTION:

When installing, be careful not to damage the torque converter clutch case bushing and oil seal.

Tightening torque:

41 N·m (4.2 kgf-m, 30.4 ft-lb)

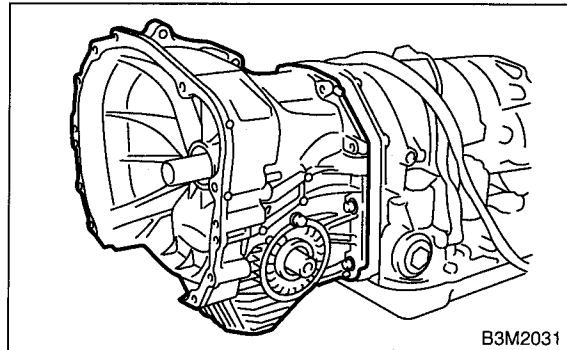

15) Install the control valve body and oil pan. <Ref. to AT-84 INSTALLATION, Control Valve Body.>

16) Apply proper amount of liquid gasket to the entire torque converter clutch case mating surface.

Liquid gasket:

THREE BOND 1215

NOTE:

Make sure that the rubber seal and seal pipe are fitted in position.

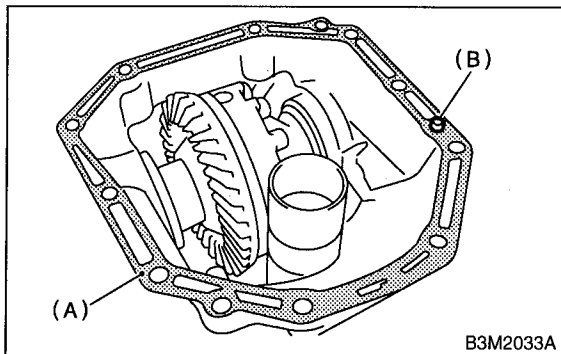

- (A) Rubber seal
- (B) Seal pipe

18) Install air breather hose. <Ref. to AT-27 INSTALLATION, Air Breather Hose.>

19) Insert inhibitor switch and transmission connector into stay.

20) Install the oil cooler pipes. <Ref. to AT-29 INSTALLATION, Oil Cooler Pipes.>

21) Install the oil charger pipe with O-ring. <Ref. to AT-28 INSTALLATION, Oil Charger Pipe.>

22) Insert the input shaft while turning lightly by hand.

CAUTION:

Be careful not to damage the bushing.

Normal protrusion A:

50 — 55 mm (1.97 — 2.17 in)

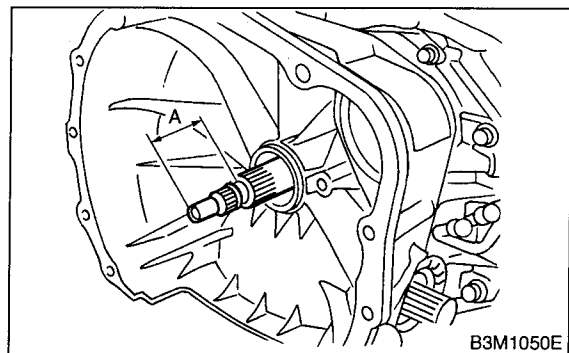

17) Install the torque converter clutch case assembly to the transmission case assembly, and secure with six bolts and four nuts.

23) Install the torque converter clutch assembly. <Ref. to AT-34 INSTALLATION, Torque Converter Clutch Assembly.>

C: INSPECTION

SS10205A10

- Drive plate facing for wear and damage
- Snap ring for wear and spring retainer for deformation
- Lip seal and lathe cut seal ring for damage
- Measure the total end play and adjust to within specifications. <Ref. to AT-68 ADJUSTMENT, Oil Pump.>