

27. Low and Reverse Brake SS10594

A: REMOVAL SS10594A18

- 1) Extract the torque converter clutch assembly. <Ref. to AT-34 REMOVAL, Torque Converter Clutch Assembly.>
- 2) Remove the input shaft.
- 3) Disconnect transmission harness connector from stay.

NOTE:

Lift-up lever behind the connector and disconnect it from stay.

- 4) Disconnect inhibitor switch connector from stay.
- 5) Disconnect the air breather hose. <Ref. to AT-27 REMOVAL, Air Breather Hose.>
- 6) Remove the oil charger pipe. <Ref. to AT-28 REMOVAL, Oil Charger Pipe.>
- 7) Remove the oil cooler inlet and outlet pipes. <Ref. to AT-29 REMOVAL, Oil Cooler Pipes.>
- 8) Separation of torque converter clutch case and transmission case sections

CAUTION:

- Be careful not to damage the oil seal and bushing inside the torque converter clutch case by the oil pump cover.
- Be careful not to lose the rubber seal.

NOTE:

Separate these cases while tapping lightly on the housing.

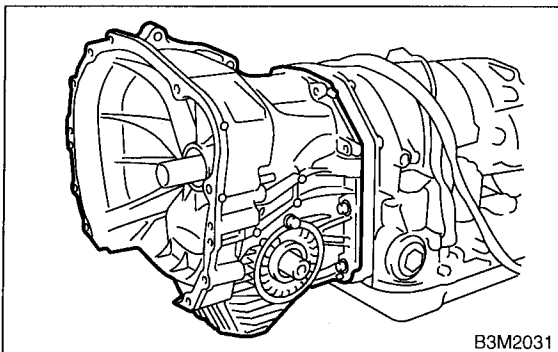

- 9) Remove rear vehicle speed sensor.

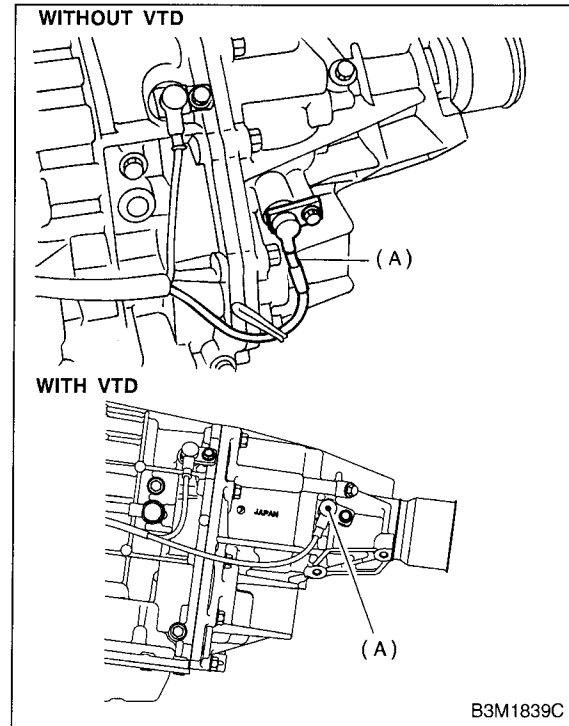

(A) Rear vehicle speed sensor

- 10) Separate transmission case and extension case sections. <Ref. to AT-36 REMOVAL, Extension Case.>
- 11) Remove the reduction driven gear. WITHOUT VTD <Ref. to AT-48 WITHOUT VTD, REMOVAL, Reduction Driven Gear.> WITH VTD <Ref. to AT-48 WITH VTD, REMOVAL, Reduction Driven Gear.>
- 12) Remove the reduction drive gear. <Ref. to AT-50 REMOVAL, Reduction Drive Gear.>
- 13) Place two wooden blocks on the workbench, and stand the transmission case with its rear end facing down.

CAUTION:

- Be careful not to scratch the rear mating surface of the transmission case.
- Note that the parking rod and drive pinion protrude from the mating surface.

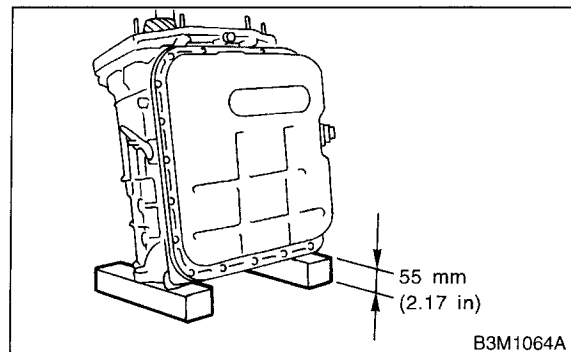

14) Remove the oil pump housing.

CAUTION:

Be careful not to lose the total end play adjusting thrust washer.

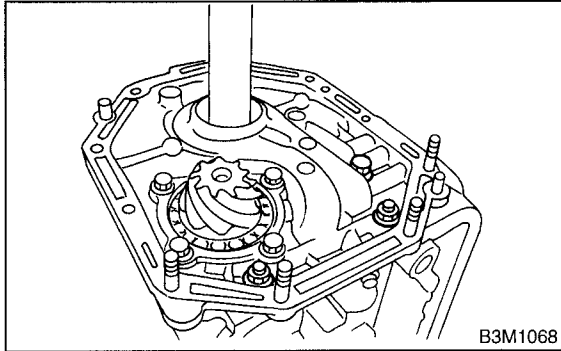

15) Remove oil pan.

16) Remove control valve assembly. <Ref. to AT-83 REMOVAL, Control Valve Body Assembly.>

17) Take out the high clutch and reverse clutch assembly. <Ref. to AT-89 REMOVAL, High Clutch and Reverse Clutch.>

18) Pull out leaf spring.

CAUTION:

Be careful not to bend leaf spring during removal.

NOTE:

Remove it while pressing down on lower leaf spring.

19) Remove snap ring and thrust needle bearing.

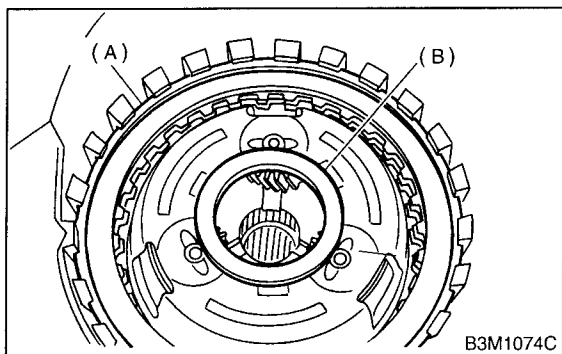

- (A) Snap ring
- (B) Thrust needle bearing

20) Take out retaining plate, drive plate and driven plate of 2-4 brake.

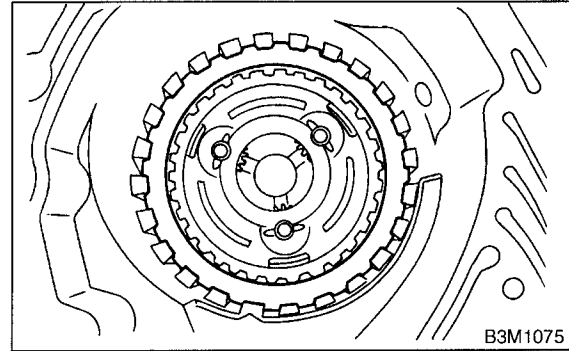

21) Take out the thrust needle bearing, planetary gear assembly. <Ref. to AT-95 REMOVAL, Planetary Gear and Low Clutch.>

22) Remove snap ring.

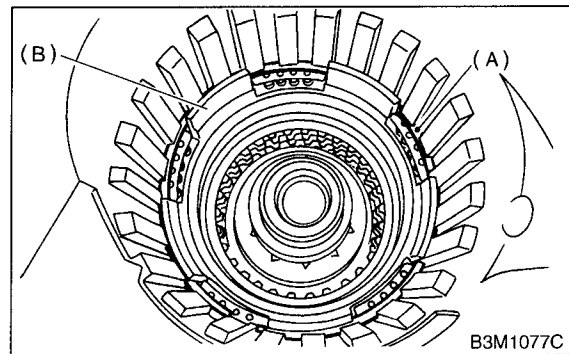

- (A) Snap ring

23) Take out 2-4 brake return spring, piston and piston retainer. <Ref. to AT-104 REMOVAL, 2-4 Brake.>

24) Pull out leaf spring.

CAUTION:

Be careful not to bend leaf spring during removal.

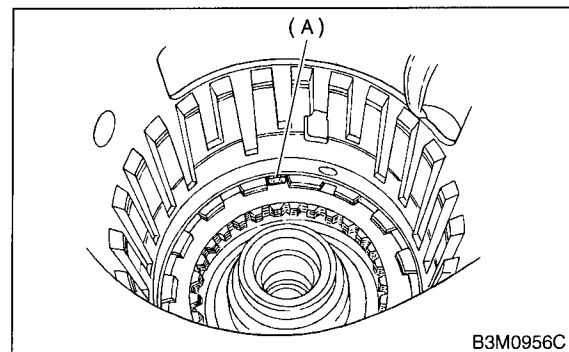

- (A) Leaf spring

LOW AND REVERSE BRAKE

Automatic Transmission

25) Remove snap ring.

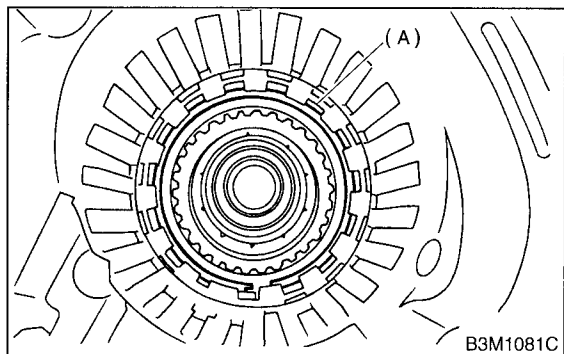

(A) Snap ring

26) Take out retaining plate, drive plate, driven plate and dish plate.

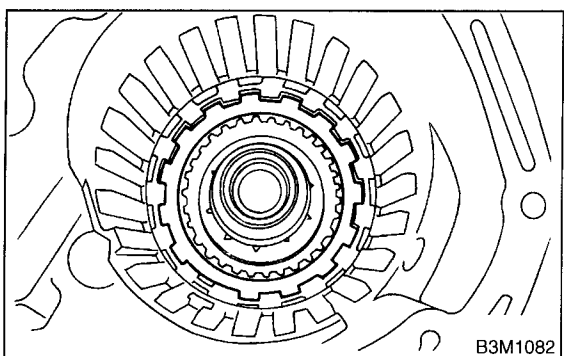

27) Turn the transmission case upside down, and then take out the socket bolts while holding the one-way clutch inner race with hand.

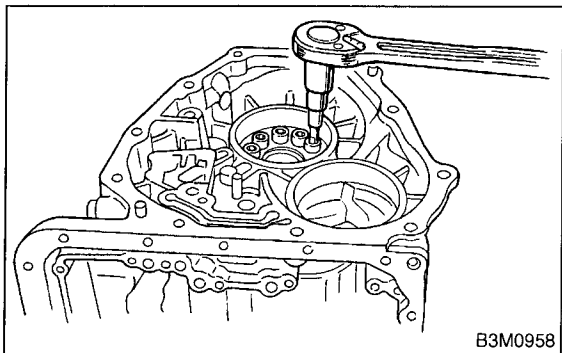

28) Take out the low & reverse piston by applying compressed air.

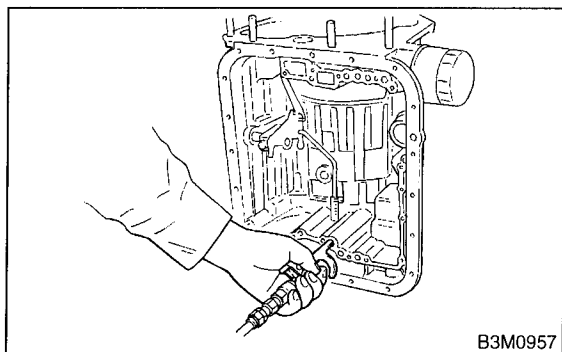

29) Take out the spring retainer, return spring and low & reverse piston.

B: INSTALLATION SS10594A11

1) Install the low and reverse piston.

CAUTION:

- Be careful not to tilt the piston when installing.
- Be careful not to damage the lip seal.

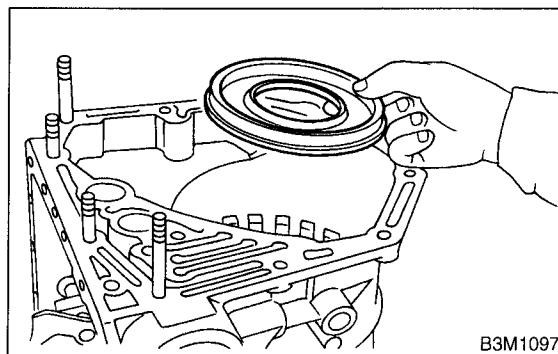

2) Install return spring

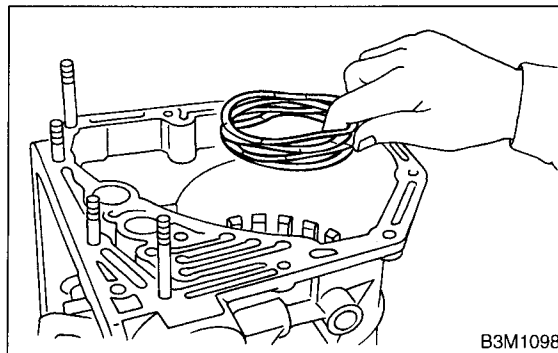

3) Install spring retainer.

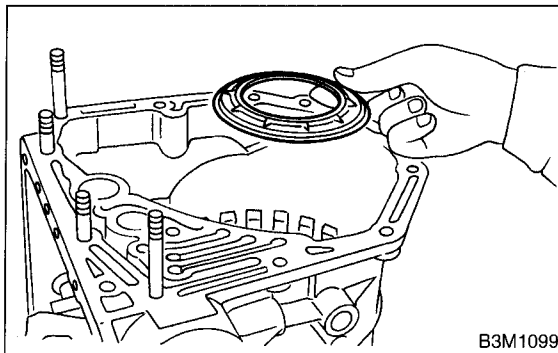

4) Install the one-way clutch inner race.

5) Tighten eight socket head bolts from the rear side of the transmission case.

Tightening torque:

25 N·m (2.5 kgf-m, 18.1 ft-lb)

CAUTION:

Be sure to tighten evenly.

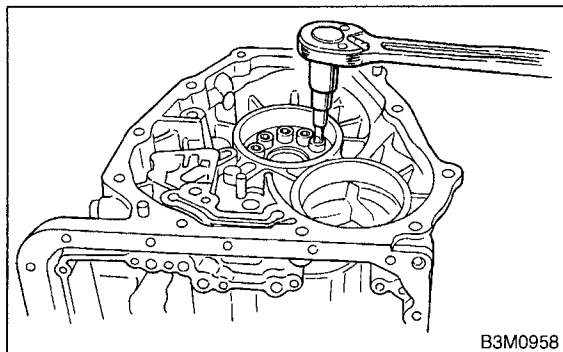

6) Install thrust needle bearing.

NOTE:

Place transmission case with the front facing up.

7) Installation of the low & reverse brake: Install dish plate, driven plates, drive plates, and a retaining plate, and secure with a snap ring.

NOTE:

Pay attention to the orientation of the dish plate.

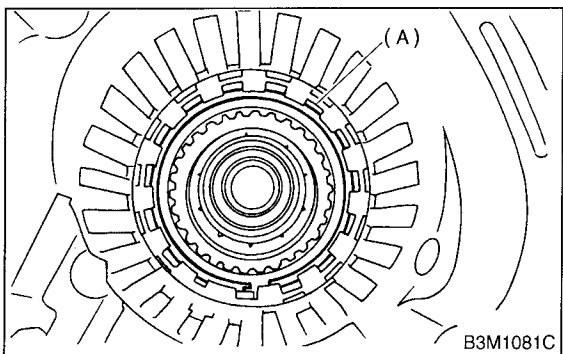

(A) Snap ring

8) Apply compressed air intermittently to check for operation.

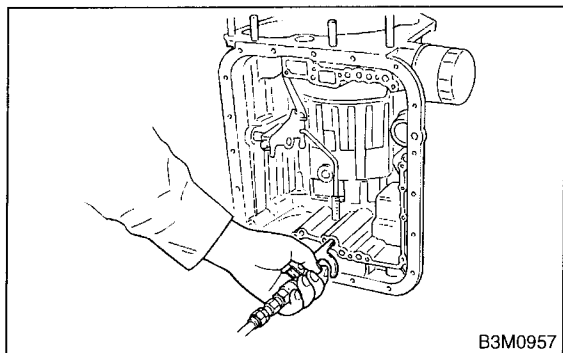

9) Check the clearance. (Selection of retaining plate)

NOTE:

Before measuring clearance, place the same thickness of shim on both sides to prevent retaining plate from tilting.

Standard value:

0.7 — 1.2 mm (0.028 — 0.047 in)

Allowable limit:

2.2 mm (0.087 in)

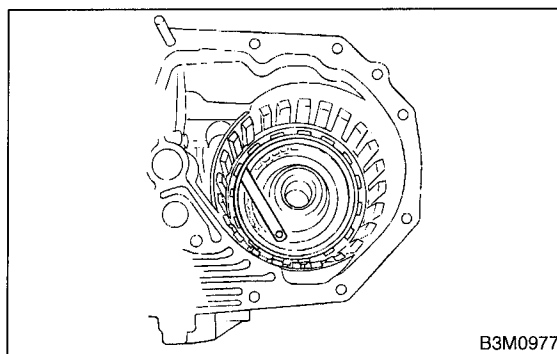

| Available retaining plates | |
|----------------------------|-------------------|
| Part No. | Thickness mm (in) |
| 31667AA320 | 4.2 (0.165) |
| 31667AA330 | 4.5 (0.177) |
| 31667AA340 | 4.8 (0.189) |
| 31667AA350 | 5.1 (0.201) |
| 31667AA360 | 5.4 (0.213) |
| 31667AA370 | 5.7 (0.224) |
| 31667AA380 | 6.0 (0.236) |

10) Install leaf spring of low and reverse brake.

CAUTION:

Pay attention to the direction and position of leaf spring during installation.

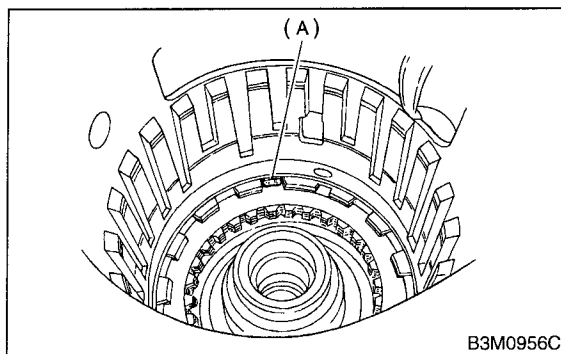

(A) Leaf spring

11) Install 2-4 brake piston, retainer and return spring to transmission case. <Ref. to AT-106 INSTALLATION, 2-4 Brake.>

LOW AND REVERSE BRAKE

Automatic Transmission

- 12) Position snap ring in transmission. Using ST, press the snap ring into place.
ST 498677100 COMPRESSOR

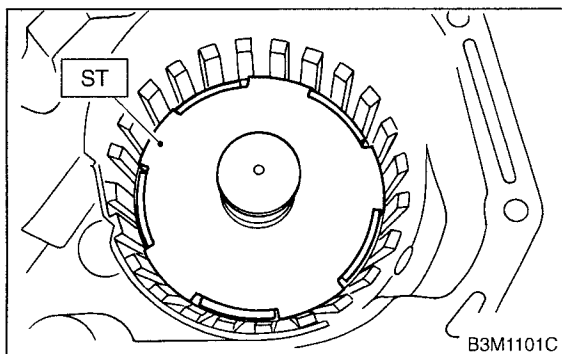

- 13) Install planetary gear and low clutch assembly to transmission case.
Install carefully while rotating the low clutch and planetary gear assembly slowly paying special attention not to damage the seal ring. <Ref. to AT-96 INSTALLATION, Planetary Gear and Low Clutch.>
14) Install pressure plate, drive plate, driven plate, retaining plate and snap ring.

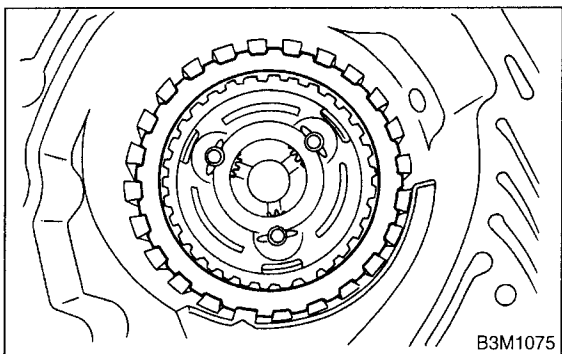

- 15) After all 2-4 brake component parts have been installed, blow in air intermittently and confirm the operation of the brake.

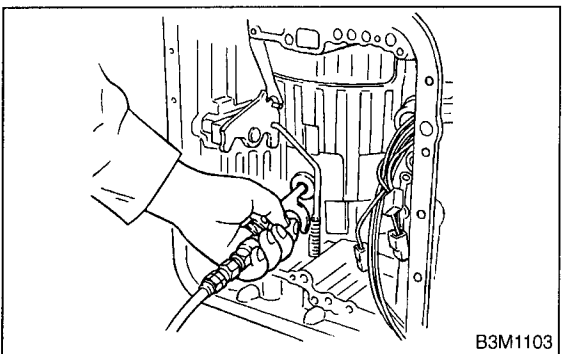

- 16) Install leaf spring of 2-4 brake.

NOTE:

Be careful not to mistake the location of the leaf spring to be inserted.

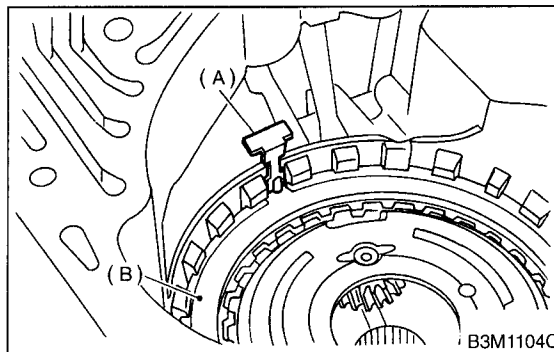

- (A) Leaf spring
- (B) Retaining plate

- 17) Install snap ring and thrust needle bearing.

NOTE:

Install thrust needle bearing in the correct direction.

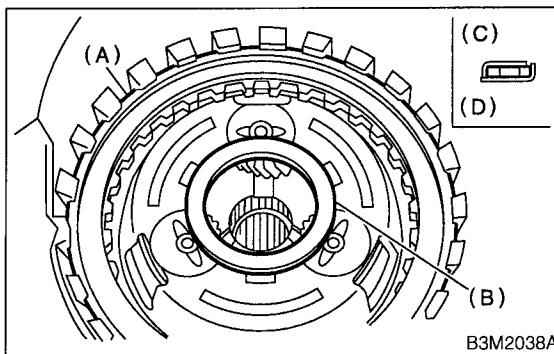

- (A) Snap ring
- (B) Thrust needle bearing
- (C) Up side
- (D) Down side

18) Install front sun gear and thrust needle bearing.

NOTE:

Install thrust needle bearing in the correct direction.

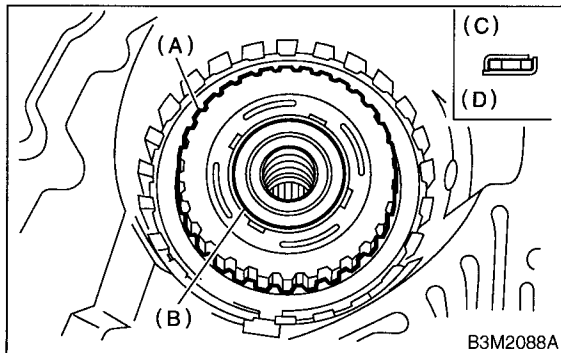

- (A) Front sun gear
- (B) Thrust needle bearing
- (C) Up side
- (D) Down side

22) Secure the housing with two nuts and the bolt.

Tightening torque:

T: 41 N·m (4.2 kgf·m, 30.4 ft·lb)

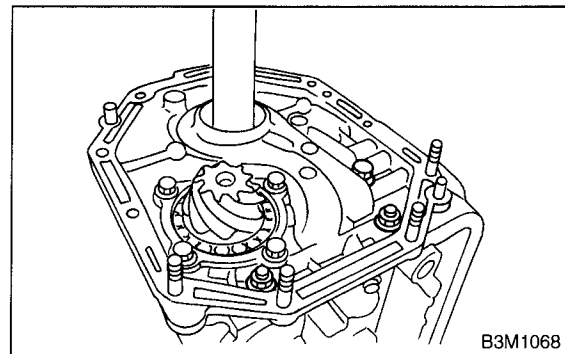

23) Apply proper amount of liquid gasket to the entire torque converter clutch case mating surface.

Liquid gasket:

THREE BOND 1215

NOTE:

Make sure that the rubber seal and seal pipe are fitted in position.

19) Install the high clutch hub and thrust needle bearing.

Attach the thrust needle bearing to the hub with vaseline and install the hub by correctly engaging the splines of the front planetary carrier.

NOTE:

Install thrust needle bearing in the correct direction.

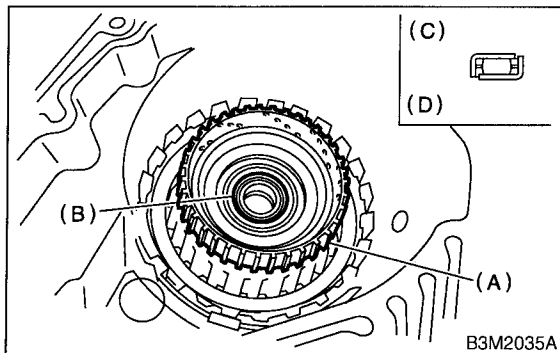

- (A) High clutch hub
- (B) Thrust needle bearing
- (C) Up side
- (D) Down side

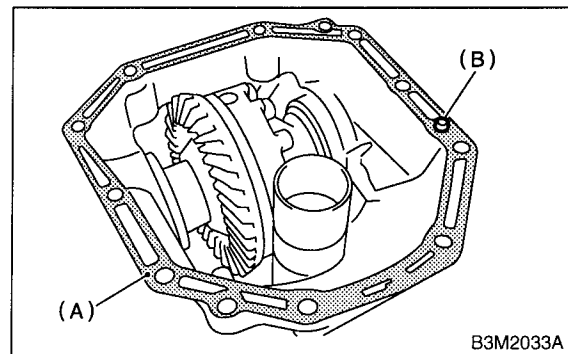

- (A) THREE BOND (Part No. 1215)
- (B) Rubber seal

24) Install the torque converter clutch case assembly to the transmission case assembly, and secure with six bolts and four nuts.

CAUTION:

When installing, be careful not to damage the torque converter clutch case bushing and oil seal.

Tightening torque:

41 N·m (4.2 kgf·m, 30.4 ft·lb)

25) Install reduction drive gear. <Ref. to AT-48 INSTALLATION, Reduction Drive Gear.>

26) Install reduction driven gear.

WITHOUT VTD <Ref. to AT-48 WITHOUT VTD, INSTALLATION, Reduction Driven Gear.>

WITH VTD <Ref. to AT-49 WITH VTD, INSTALLATION, Reduction Driven Gear.>

20) Install the high clutch assembly. <Ref. to AT-90 INSTALLATION, High Clutch and Reverse Clutch.>

21) Install the oil pump housing assembly.

LOW AND REVERSE BRAKE

Automatic Transmission

27) Install the extension case to the transmission case. <Ref. to AT-36 INSTALLATION, Extension Case.>

28) Install the rear vehicle speed sensor.

Tightening torque:

7 N·m (0.7 kgf-m, 5.1 ft-lb)

29) Install air breather hose. <Ref. to AT-27 INSTALLATION, Air Breather Hose.>

30) Insert inhibitor switch and transmission connector into stay.

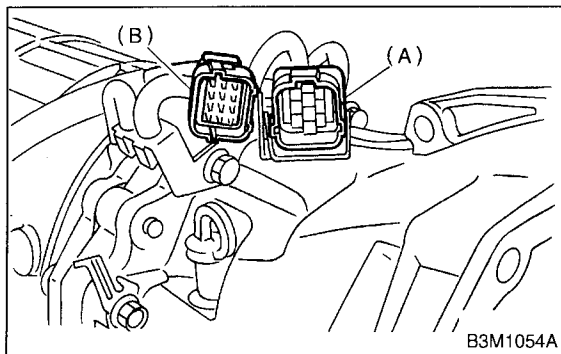

(A) Transmission harness

(B) Inhibitor switch harness

31) Install the oil cooler pipes. <Ref. to AT-29 INSTALLATION, Oil Cooler Pipes.>

32) Install the oil charger pipe with O-ring. <Ref. to AT-28 INSTALLATION, Oil Charger Pipe.>

33) Insert the input shaft while turning lightly by hand.

CAUTION:

Be careful not to damage the bushing.

Normal protrusion A:

50 — 55 mm (1.97 — 2.17 in)

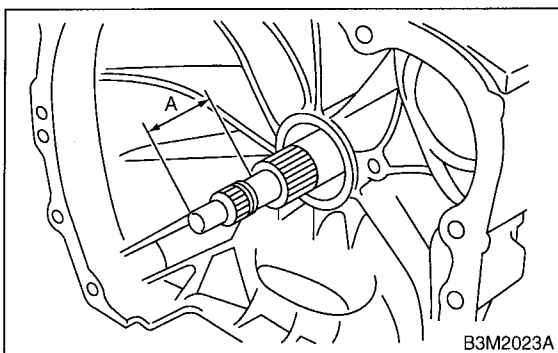

34) Install the torque converter clutch assembly. <Ref. to AT-34 INSTALLATION, Torque Converter Clutch Assembly.>

C: INSPECTION SS10594A10

Check for the following.

- Drive plate facing for wear or damage
- Snap ring for wear and spring retainer for deformation