

CRUISE CONTROL MODULE I/O SIGNAL

Cruise Control System (DIAGNOSTICS)

4. Cruise Control Module I/O Signal S003515

A: ELECTRICAL SPECIFICATION S003515A08

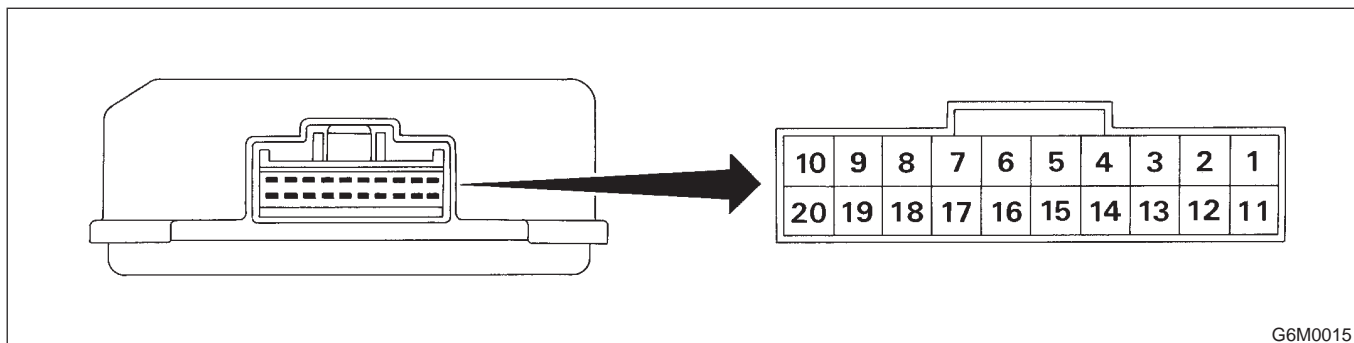

G6M0015

Content	Terminal No.	Measuring conditions and I/O signals (ignition switch ON and engine idling)
Main light	1	<ul style="list-style-type: none"> Battery voltage is present when main switch is turned OFF. "0" volt is present when main switch is turned ON.
Inhibitor switch (AT)	4	<ul style="list-style-type: none"> Battery voltage is present when selector lever is other than "P" or "N" position. "0" volt is present when selector lever is set to "P" or "N" position.
Motor B	5	<ul style="list-style-type: none"> ON-and-OFF ("0"-and-battery voltage) operation is alternately repeated while cruise control is operating. "0" volt is present when main switch is turned OFF.
Ground	6	—
Motor A	7	<ul style="list-style-type: none"> ON-and-OFF ("0"-and-battery voltage) operation is alternately repeated while cruise control is operating. "0" volt is present when main switch is turned OFF.
RESUME/ACCEL switch	9	<ul style="list-style-type: none"> Battery voltage is present when command switch is turned to RESUME/ACCEL position. "0" volt is present when command switch is released.
SET/COAST switch	10	<ul style="list-style-type: none"> Battery voltage is present when command switch is turned to SET/COAST position. "0" volt is present when command switch is released.
Main power supply	11	<ul style="list-style-type: none"> Battery voltage is present when main power is turned ON. "0" volt is present when main power is turned OFF.
Ignition switch	12	<ul style="list-style-type: none"> Battery voltage is present when ignition switch is turned ON. "0" volt is present when ignition switch is turned OFF.
Motor C	13	<ul style="list-style-type: none"> ON-and-OFF ("0"-and-battery voltage) operation is alternately repeated while cruise control is operating. "0" volt is present when main switch is turned OFF.
Motor clutch	14	<ul style="list-style-type: none"> ON-and-OFF ("0"-and-battery voltage) operation is alternately repeated while cruise control is operating. "0" volt is present when vehicle is stopped.
Cruise control main switch	15	<ul style="list-style-type: none"> Battery voltage is present during pressing the cruise control main switch, and then battery voltage is present while main switch is turned ON. "0" volt is present when main switch is turned OFF.
Brake switch	16	<p>Leave clutch pedal released (MT), while cruise control main switch is turned ON.</p> <p>Then check that;</p> <ul style="list-style-type: none"> Battery voltage is present when brake pedal is released. "0" volt is present when brake pedal is depressed. <p>Additionally only in MT vehicle, keep the cruise control main switch to ON and leave brake pedal released.</p> <p>Then check that;</p> <ul style="list-style-type: none"> Battery voltage is present when clutch pedal is released. "0" volt is present when clutch pedal is depressed.
Data link connector	17	—

CRUISE CONTROL MODULE I/O SIGNAL

Cruise Control System (DIAGNOSTICS)

Content	Terminal No.	Measuring conditions and I/O signals (ignition switch ON and engine idling)
Data link connector	18	—
Vehicle speed sensor (MT) TCM (AT)	19	Lift-up the vehicle until all four wheels are raised off ground, and then rotate any wheel manually. Approx. "5" and "0" volt pulse signals are alternately input to cruise control module.
Stop light switch	20	Turn ignition switch to OFF. Then check that; <ul style="list-style-type: none">● Battery voltage is present when brake pedal is depressed.● "0" volt is present when brake pedal is released.
NOTE: Voltage at terminals 5, 7, 13 and 14 cannot be checked unless vehicle is driving by cruise control operation.		

CRUISE CONTROL MODULE I/O SIGNAL

Cruise Control System (DIAGNOSTICS)

B: SCHEMATIC

S003515A21

1. CRUISE CONTROL 4 CYLINDER ENGINE MODEL

S003515A2101

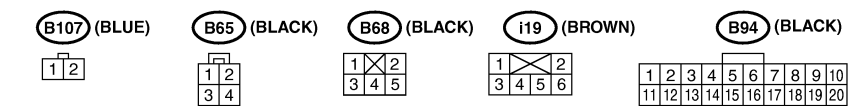
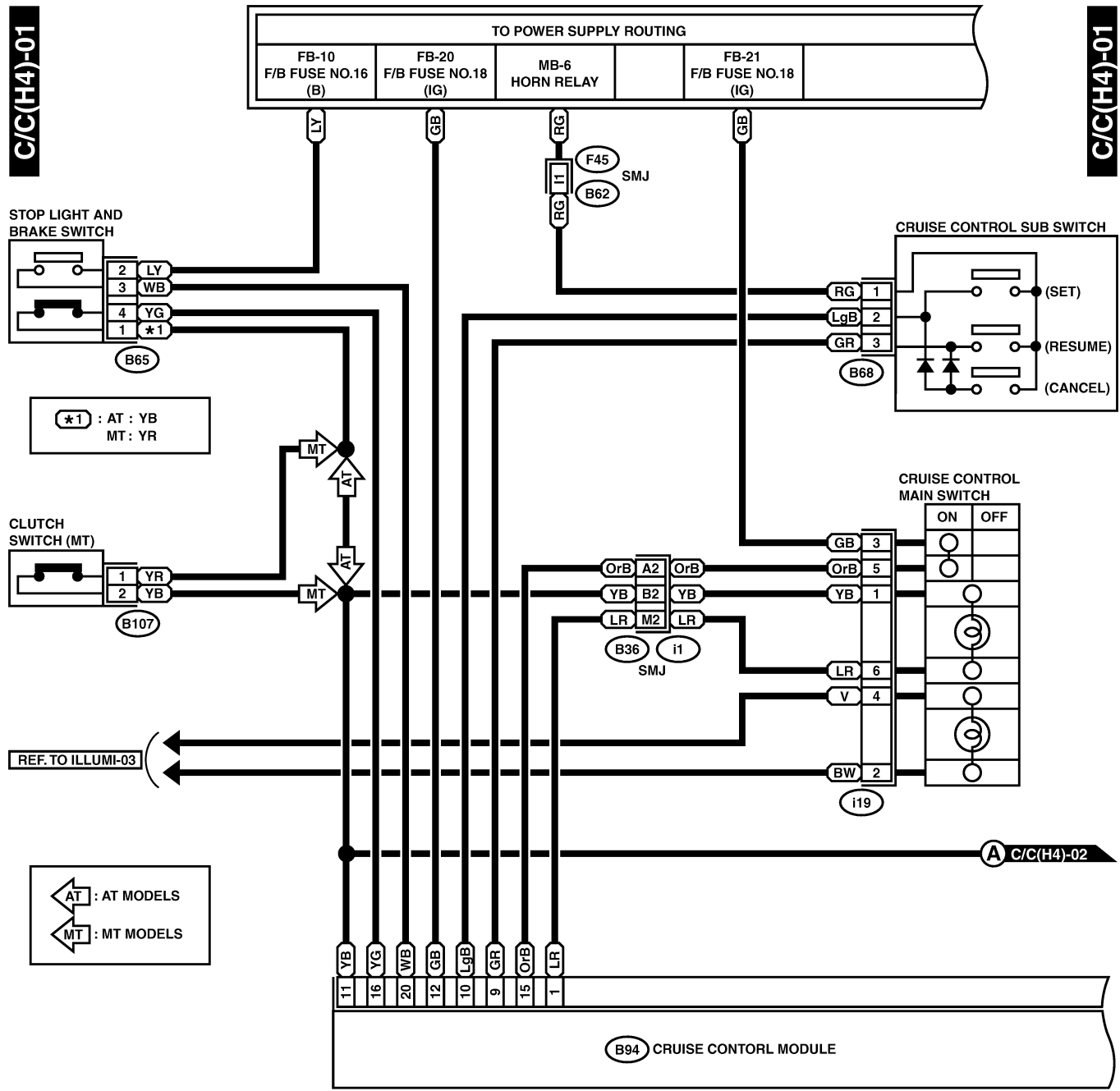

CRUISE CONTROL MODULE I/O SIGNAL

Cruise Control System (DIAGNOSTICS)

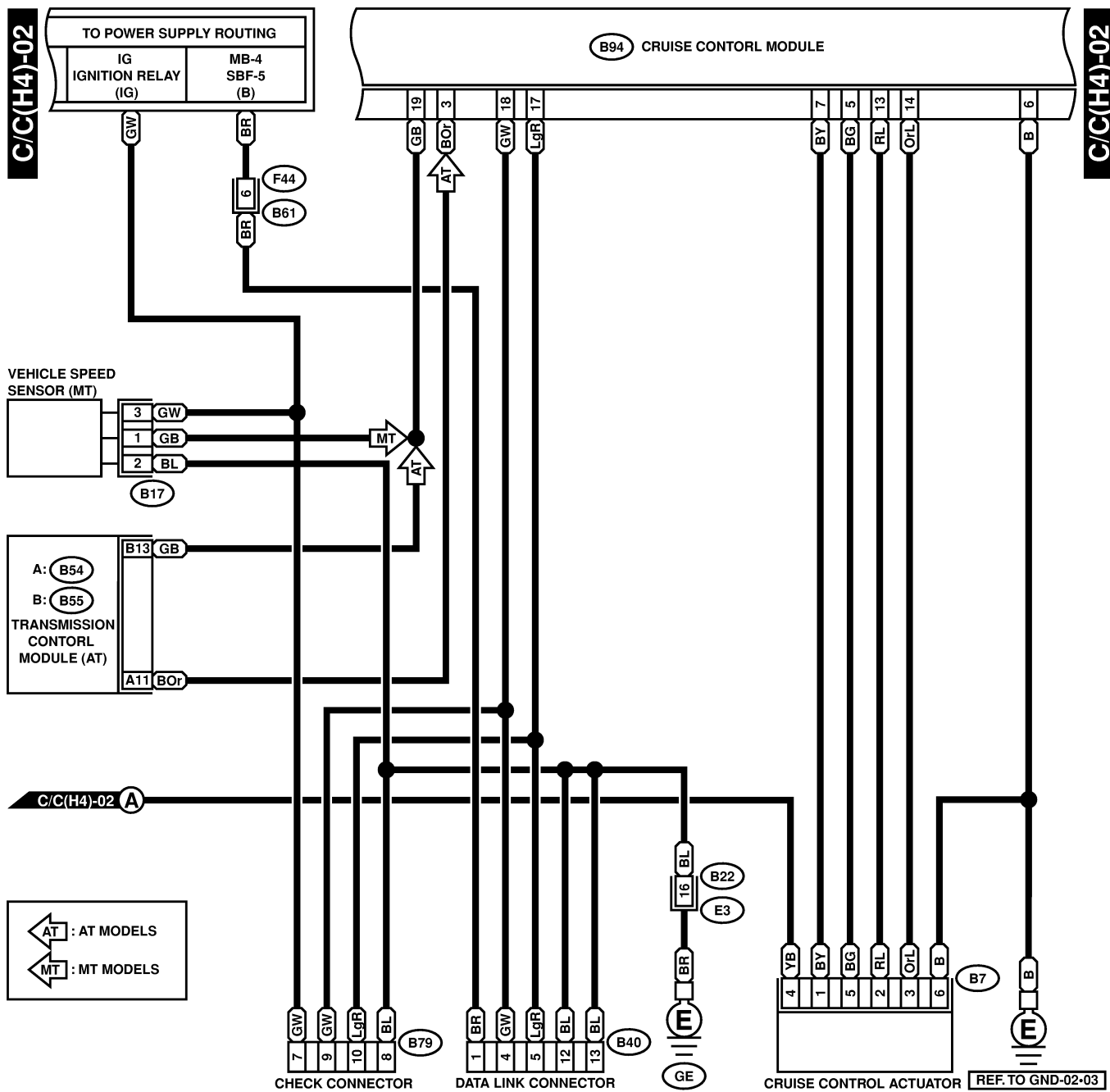

B17 (BLACK)



B7 (BLACK)



F44



B79 (GRAY)

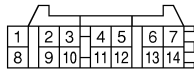

B40 (GRAY)

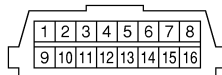

B22 (BROWN)

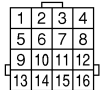

B94 (BLACK)

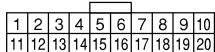

A: B54

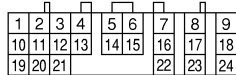

B: B55 (GRAY)

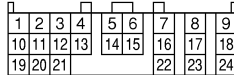

CRUISE CONTROL MODULE I/O SIGNAL

Cruise Control System (DIAGNOSTICS)

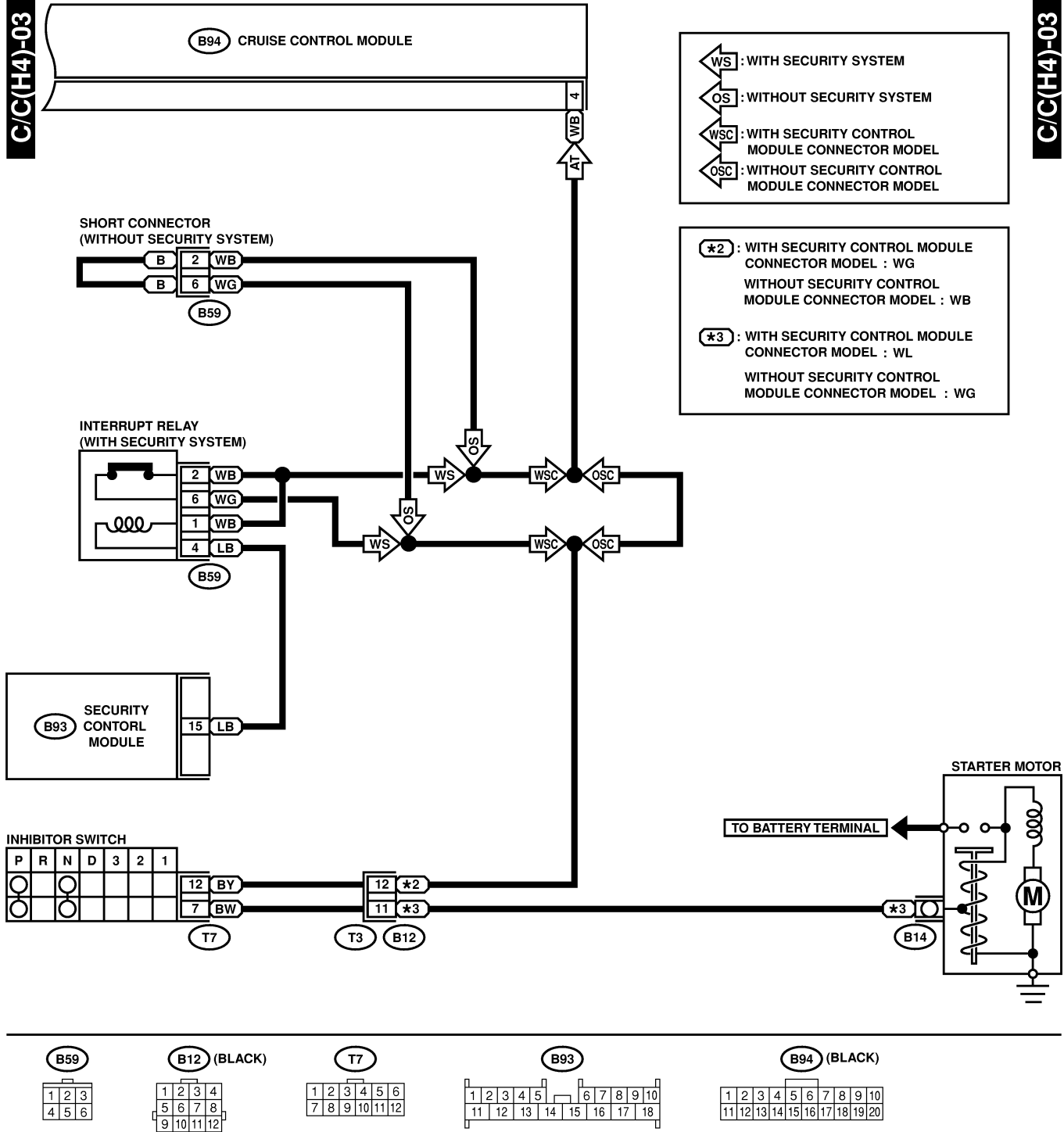

BU71-21C

CRUISE CONTROL MODULE I/O SIGNAL

Cruise Control System (DIAGNOSTICS)

2. CRUISE CONTROL 6 CYLINDER ENGINE MODEL

S003515A2102

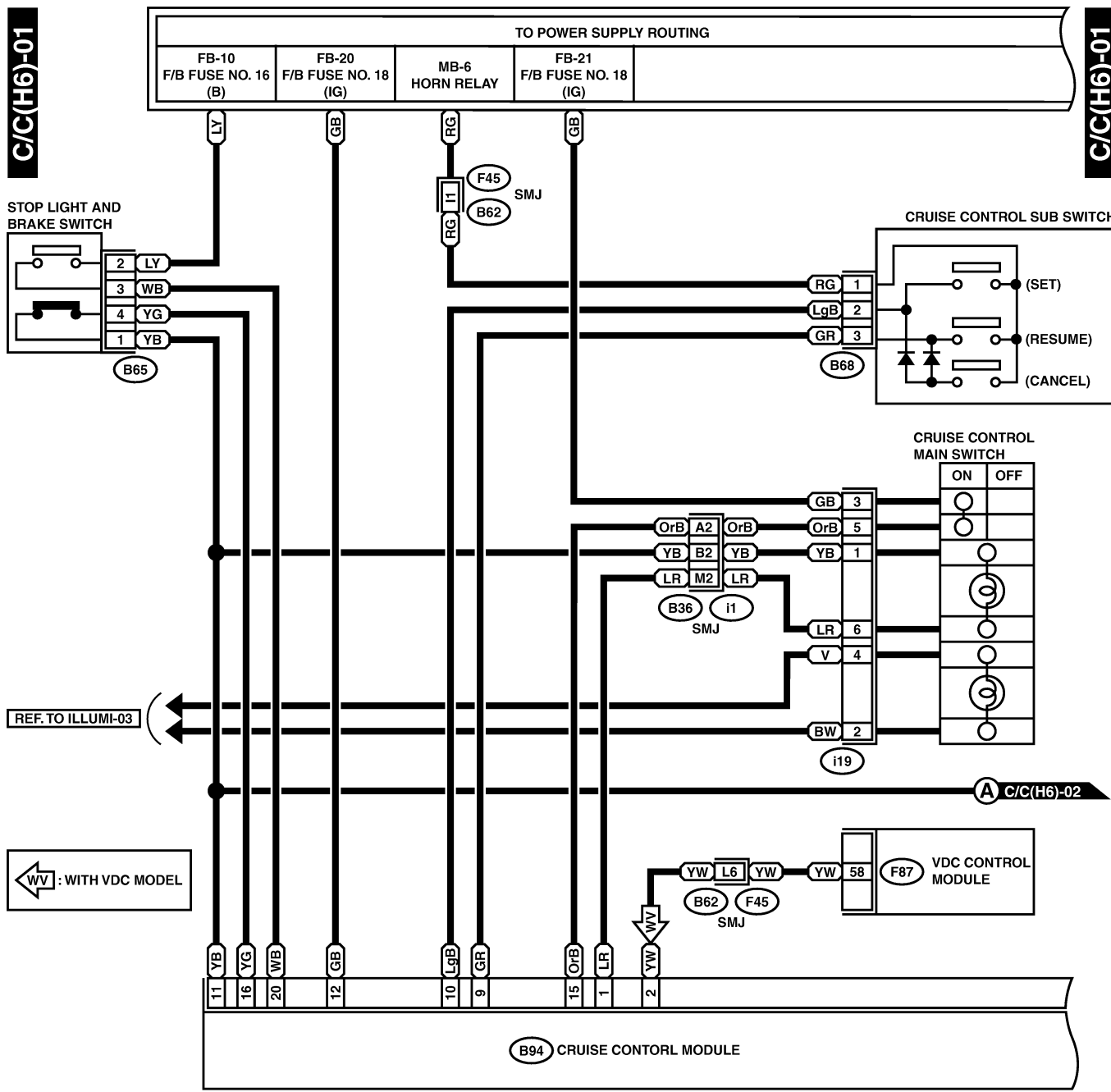

REF. TO ILLUMI-03

WV : WITH VDC MODEL

B65 (BLACK) B68 (BLACK) i19 (BROWN) B94 (BLACK)

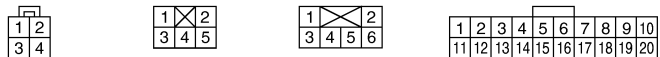

F87 (BLACK)

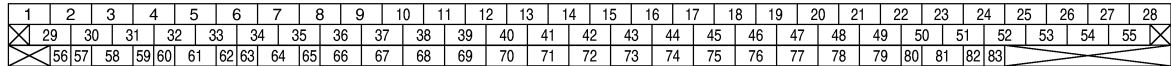

CRUISE CONTROL MODULE I/O SIGNAL

Cruise Control System (DIAGNOSTICS)

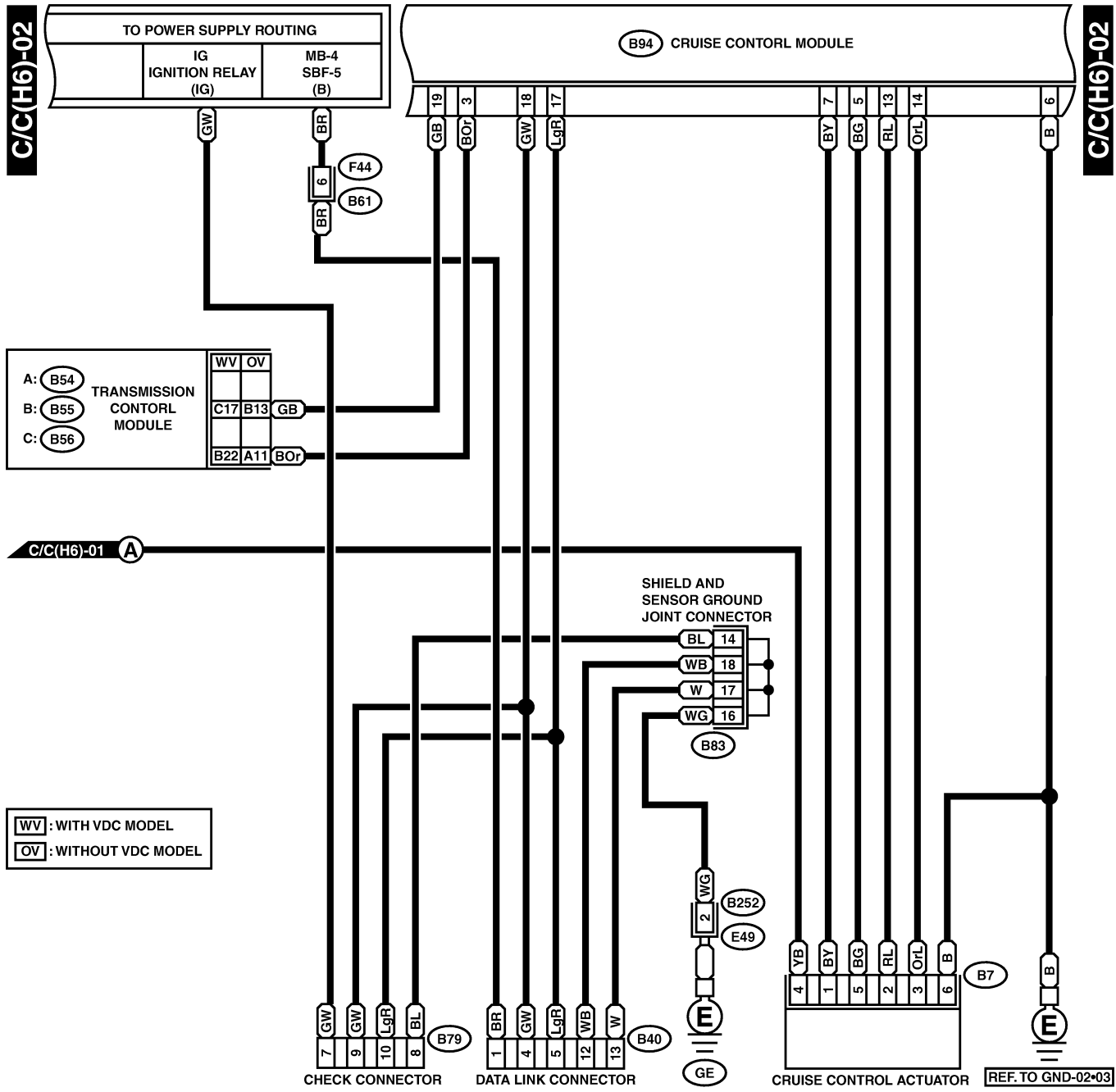

WV : WITH VDC MODEL
OV : WITHOUT VDC MODEL

REF. TO GND-02*03

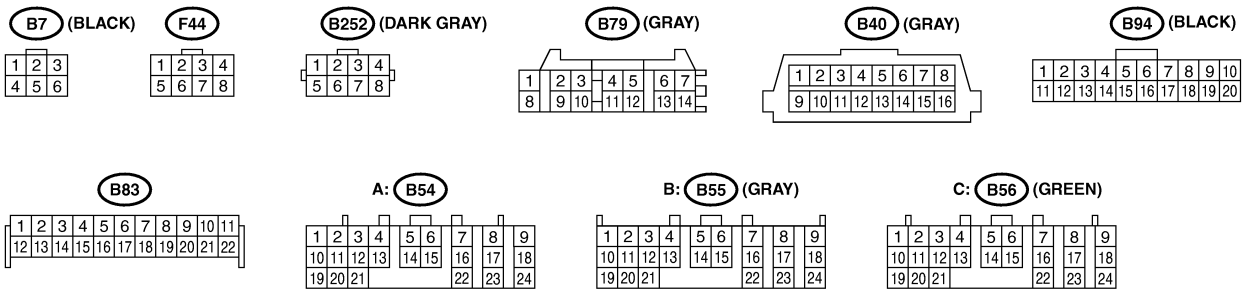

BU71-22B

CRUISE CONTROL MODULE I/O SIGNAL

Cruise Control System (DIAGNOSTICS)

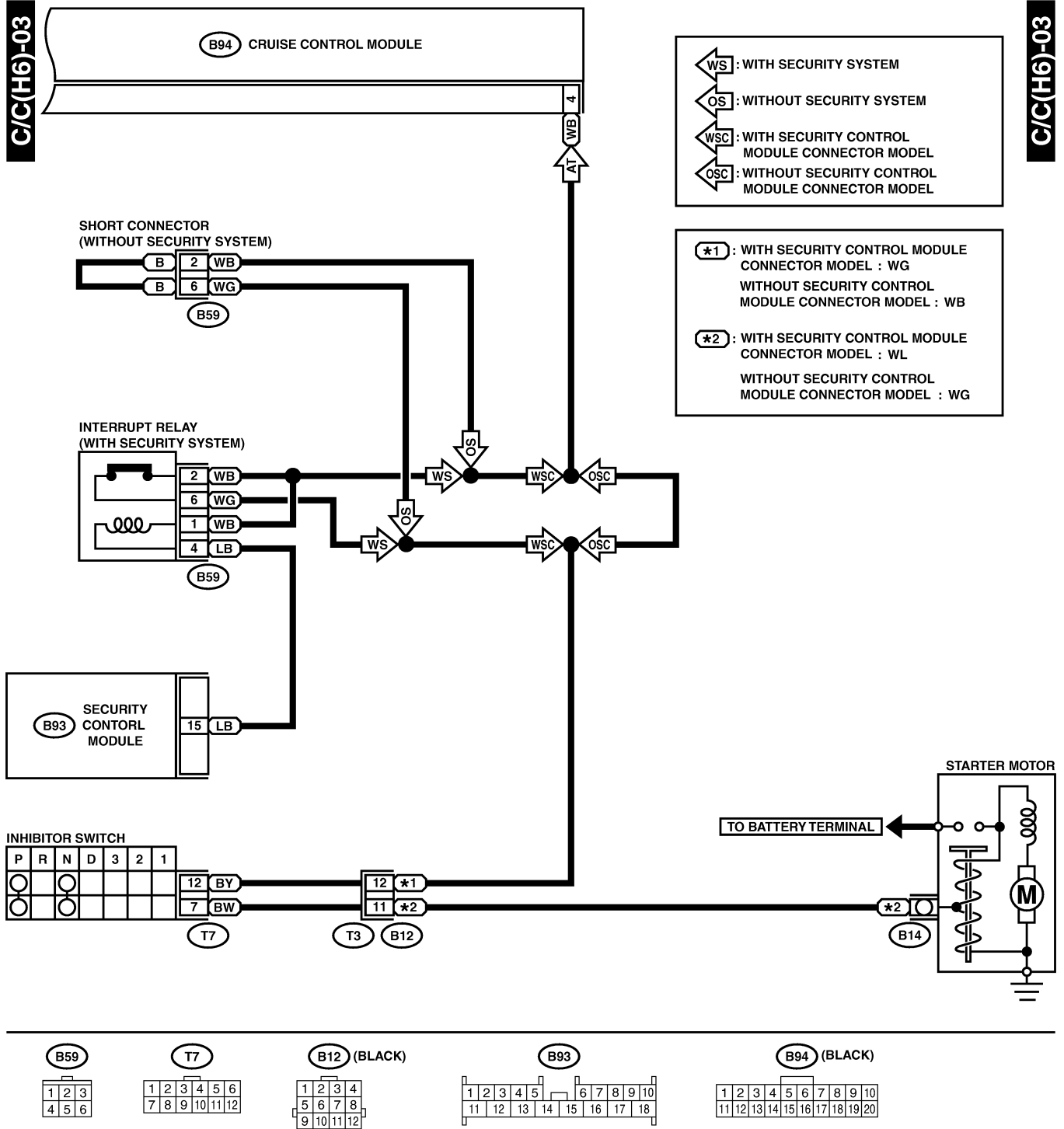

BU71-22C