

PROTECTOR

Exterior/Interior Trim

7. Protector S911380

A: REMOVAL S911380A18

1) Except OUTBACK:

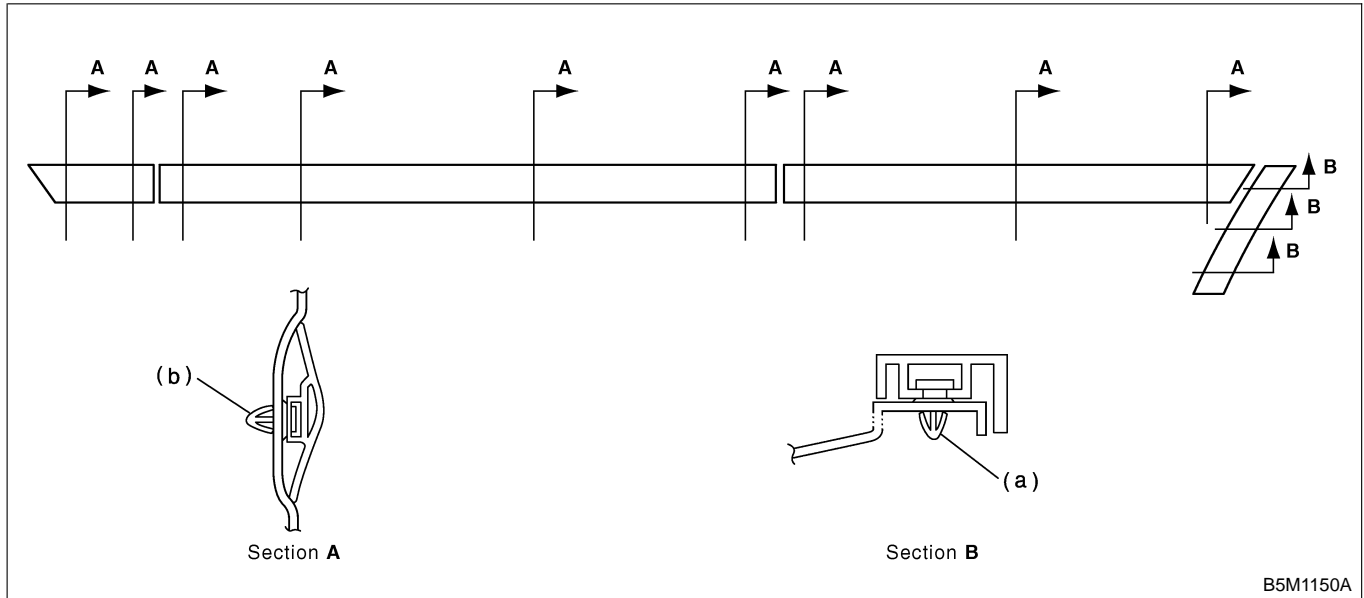

NOTE:
Paying attention to the position of clip (b).

OUTBACK:
Remove clip (a) and bolt (b).

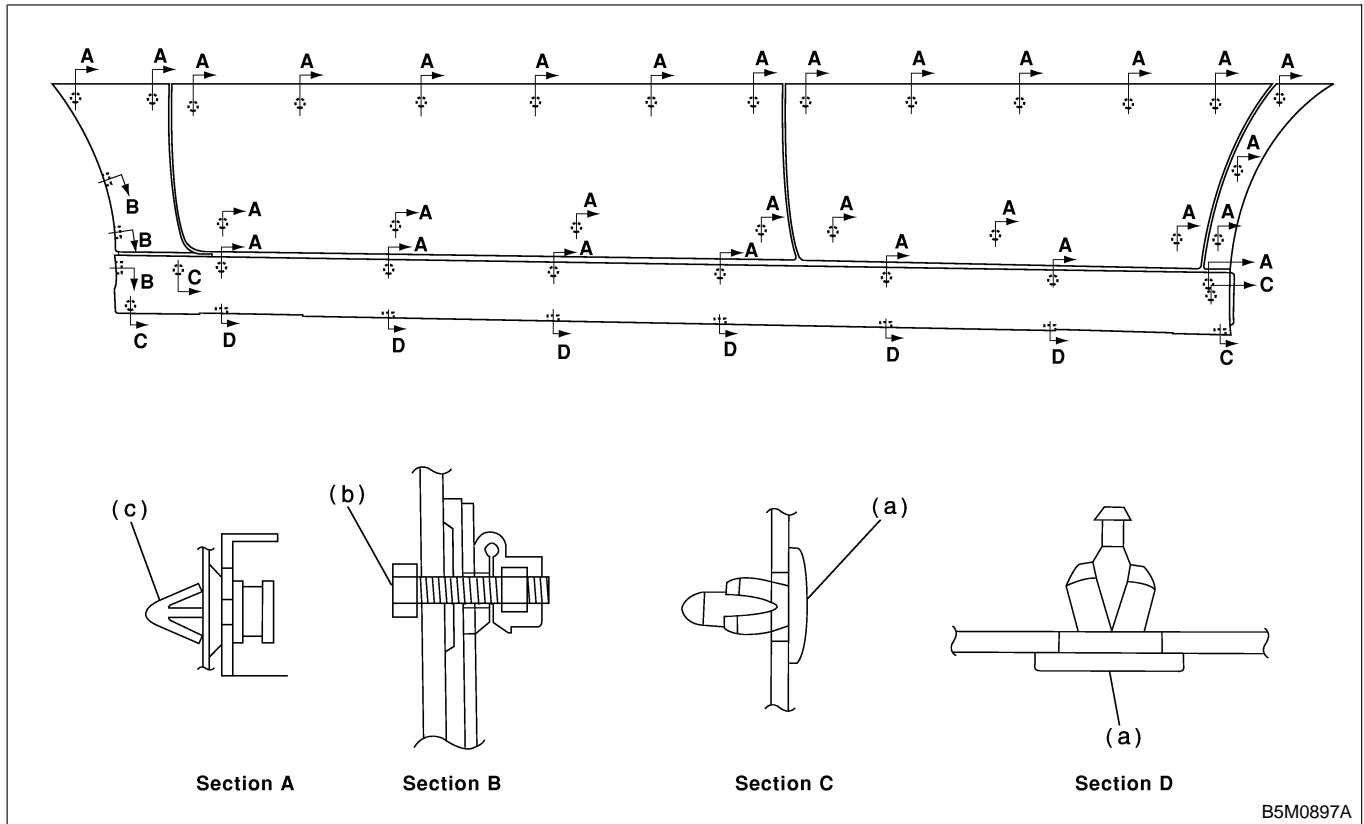

NOTE:

Paying attention to the position of clip (c).

2) Attach masking tape to outer perimeter of side protector. (If original side protector is re-installed, tape the entire protector.)

3) Insert fishing line [0.8 mm (0.31 in) dia.] between side protector and vehicle body. Cut (pull the line) through two-sided tape along side protector on the body. Using a puller, remove clips from vehicle body while pulling side protector towards yourself as required.

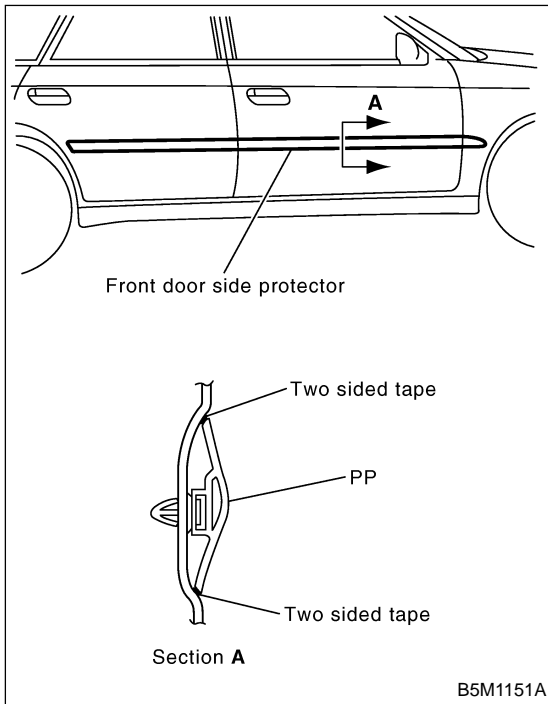
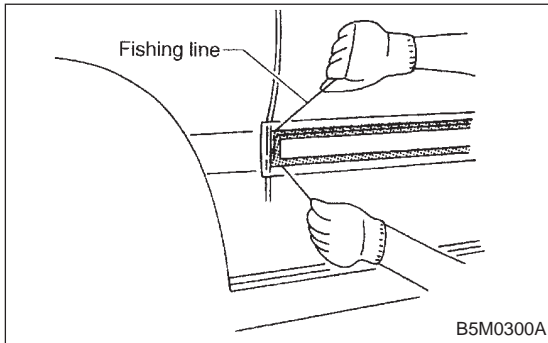

NOTE:

- To increase adhesive remover strength, leave two-sided tape on body and side protector.

- If two-sided tape is too thick, use a putty knife to cut it thin so that adhesive remover is ready for use.

- If two-sided tape is hard to remove, heat to approximately 40°C (104°F).

4) Apply an even coat of adhesive remover to the two-sided tape.

Recommended adhesive remover:

SUMITOMO 3M4000 or equivalent

CAUTION:

Do not apply adhesive remover to lacquer base coated body panels.

5) Attach plastic wrap to adhesive remover coated areas and heat to 40 to 60°C (104 to 140°F) for 5 to 10 minutes using an infrared lamp.

CAUTION:

Do not overheat until plastic wrap is somewhat white.

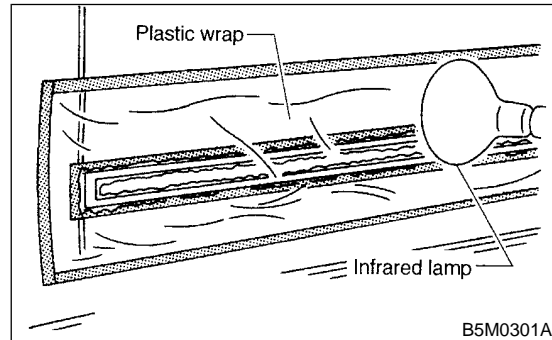

6) Using a plastic spatula, remove traces of two-sided tape from body panel.

7) Remove masking tape and clean traces of two-sided tape using a cloth dampened with white gasoline.

8) Similarly, clean traces of adhesive from two-sided tape on side protector.

CAUTION:

Make sure side protector is clean and free of adhesive remover. Clean if necessary.

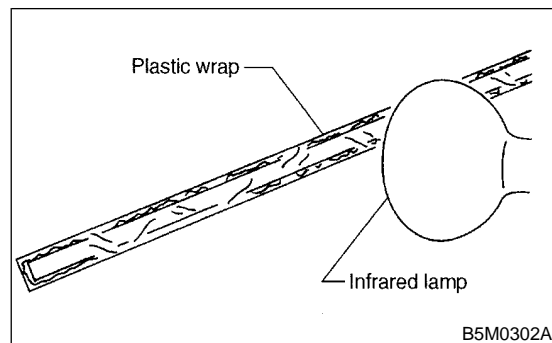

B: INSTALLATION S911380A11

1) Apply primer to original side protector (if used), and attach two-sided tape to side protectors as shown.

Two-sided tape:

Thickness; 1.2 mm (0.047 in)

Width; 5 mm (0.20 in)

Recommended primer:

SUMITOMO 3MK-500 or equivalent

Recommended two-sided tape:

SUMITOMO 3M4210 or equivalent

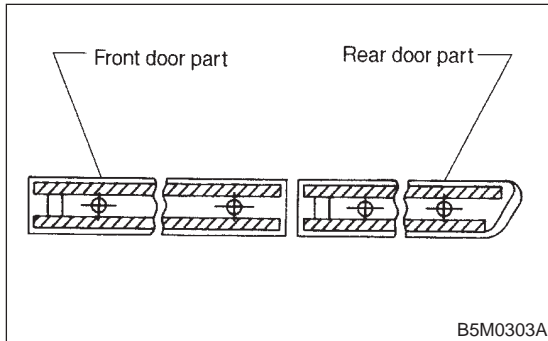

2) Using an infrared lamp, heat body panel to 40 to 60°C (104 to 140°F) and rear surface of side protector to 20 to 30°C (68 to 86°F).

3) Remove tack paper from two-sided paper. While aligning clips with holes in body panel, attach two-sided tape to side protector and body panel with a force of more than 49 N (5 kg, 11 lb) with roller. Do not allow air to enter mating surface of the two.

CAUTION:

- To maintain adhesive power, do not wash the vehicle for 24 hours after tape application.
- Push clip in securely using hands.
(To prevent deformation, do not use excessive force.)