

4. Front Door Panel S913366

A: REMOVAL S913366A18

- 1) Disconnect (-) cable from battery.
- 2) Remove front door trim. <Ref. to EI-32 REMOVAL, Front Door Trim.>
- 3) Remove outer mirror assembly. <Ref. to GW-40 REMOVAL, Outer Mirror Assembly.>
- 4) Remove front door regulator and motor. <Ref. to GW-23 REMOVAL, Front Regulator and Motor.>
- 5) Remove front door latch assembly. <Ref. to SL-36 REMOVAL, Front Door Latch Assembly.>
- 6) Remove front outer handle. <Ref. to SL-35 REMOVAL, Front Outer Handle.>
- 7) Remove front pillar lower trim to disconnect connector from body harness.

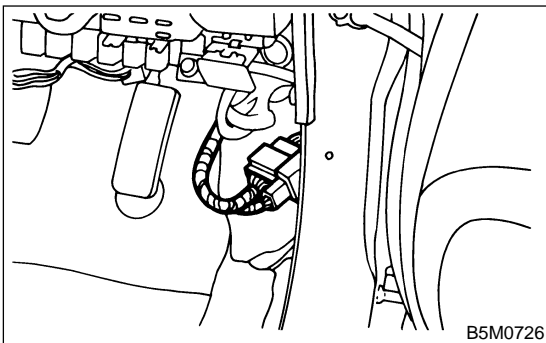

- 8) Put wooden block on jack and place jack under door. Support door with a jack to protect it from damage.
- 9) Remove checker bolts.

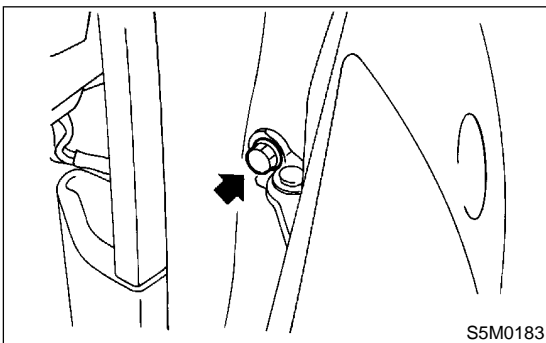

- 10) Remove door-side bolts for upper and lower hinges to remove door.

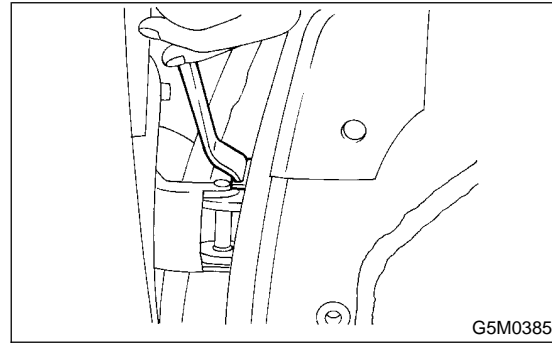

- 11) Using special tool, remove body-side bolts for upper and lower hinges, and remove door hinges. ST 925610000 DOOR HINGE WRENCH

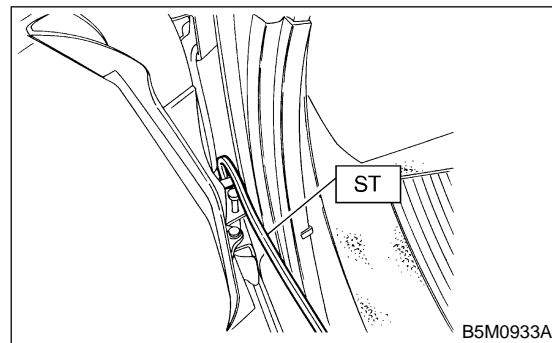

CAUTION:

- During removal and installation of doors, do not damage body.
- Doors are heavy. Be careful not to drop and damage them.

B: INSTALLATION S913366A11

- 1) Install in the reverse order of removal.
- 2) Apply grease to sliding area of door hinges.

FRONT DOOR PANEL

Exterior Body Panels

C: ADJUSTMENT S913366A01

1) Using special tool, loosen body-side bolts of upper and lower hinges to align the position of front door panel longitudinally and vertically.

ST 925610000 DOOR HINGE WRENCH

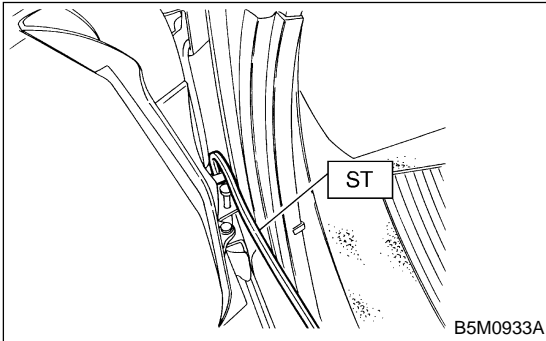

2) Loosen door-side bolts of upper and lower hinges to align the position of front door panel vertically and laterally at the front end.

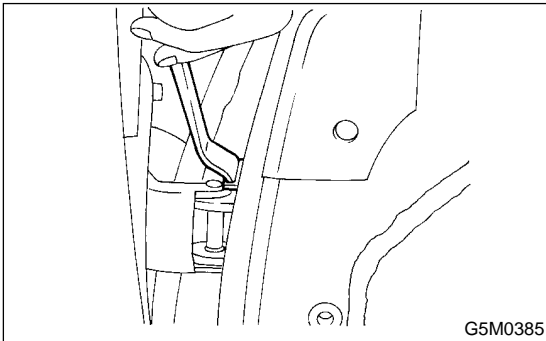

3) Loosen screw (A) and tap striker (B) using plastic hammer to adjust striker.

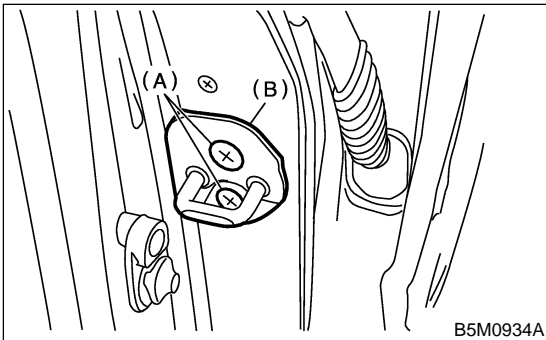

CAUTION:

Do not use impact wrench. Welding area on striker nut plate is easily broken.