

# REAR DOOR PANEL

Exterior Body Panels

## 6. Rear Door Panel S913364

### A: REMOVAL S913364A18

- 1) Disconnect (-) cable from battery.
- 2) Remove rear door trim. <Ref. to EI-33 REMOVAL, Rear Door Trim.>
- 3) Remove rear door regulator and motor assembly. <Ref. to GW-26 REMOVAL, Rear Regulator and Motor Assembly.>
- 4) Remove rear door latch. <Ref. to SL-40 REMOVAL, Rear Door Latch Assembly.>
- 5) Remove rear outer handle. <Ref. to SL-39 REMOVAL, Rear Outer Handle.>
- 6) Remove center pillar lower trim. <Ref. to EI-43 REMOVAL, Lower Inner Trim.>
- 7) Remove seatbelt bracket and blind plug.  
Disconnect connector of door harness and remove door hinge nut.

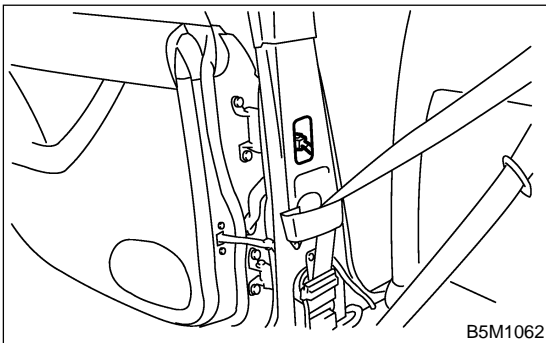

- 8) Put a wooden block on the jack and place the jack under the door. Support the door with the jack to protect it.
- 9) Remove checker bolts.

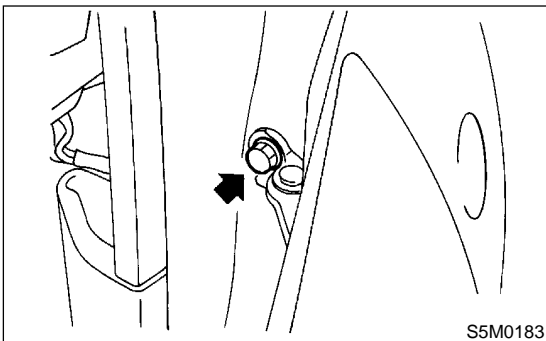

- 10) Remove door-side bolts for upper and lower hinges to remove door.

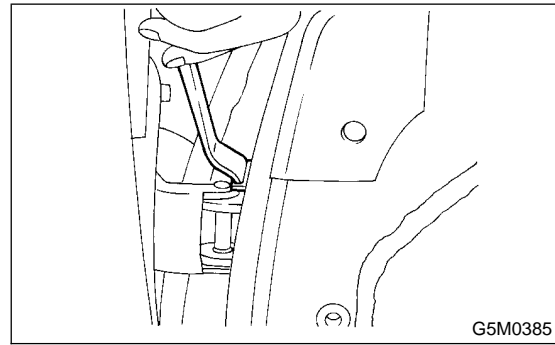

- 11) Using special tool, remove body-side bolts for upper and lower hinges, and remove door hinges.

### CAUTION:

- During removal and installation of doors, do not damage body.
- Doors are heavy. Be careful not to drop and damage them.

### B: INSTALLATION S913364A11

- 1) Install in the reverse order of removal.
- 2) Apply grease to sliding area of door hinges.

## C: ADJUSTMENT S913364A01

1) Using special tool, loosen body-side bolts of upper and lower hinges to align the position of rear door panel longitudinally and vertically.

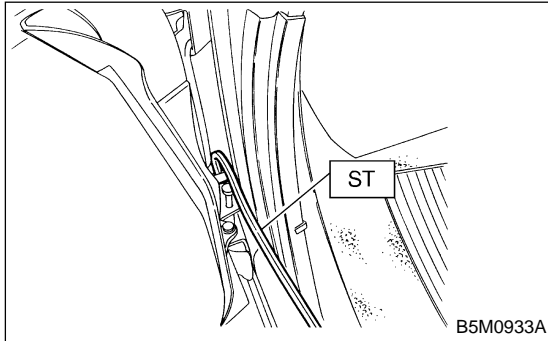

2) Loosen door-side bolts of upper and lower hinges to align the position of rear door panel vertically and laterally at front-end.

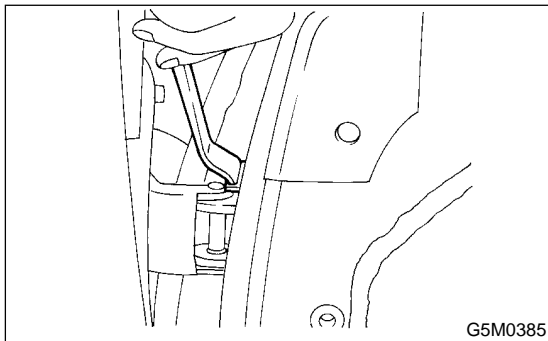

3) Loosen screw (A) and tap striker (B) using plastic hammer to adjust striker.

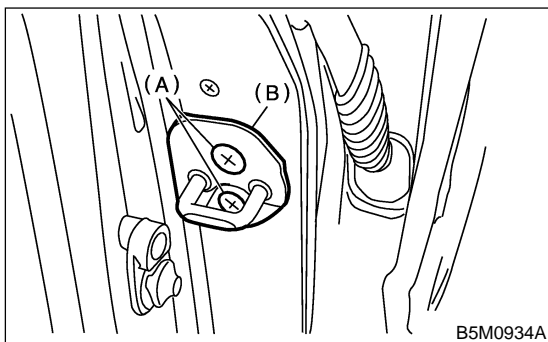

**CAUTION:**  
Do not use an impact wrench. The welding area on the striker nut plate is easily broken.