

3. Combination Meter Assembly

S907335

A: REMOVAL

S907335A18

- 1) Disconnect ground cable from battery.
- 2) Set tilt steering at the lowest position.
- 3) Disconnect each electrical connector to remove front cover (A) and switch panel (B).
- 4) Loosen screws (C) to remove center panel (D).
- 5) Remove meter visor (E).

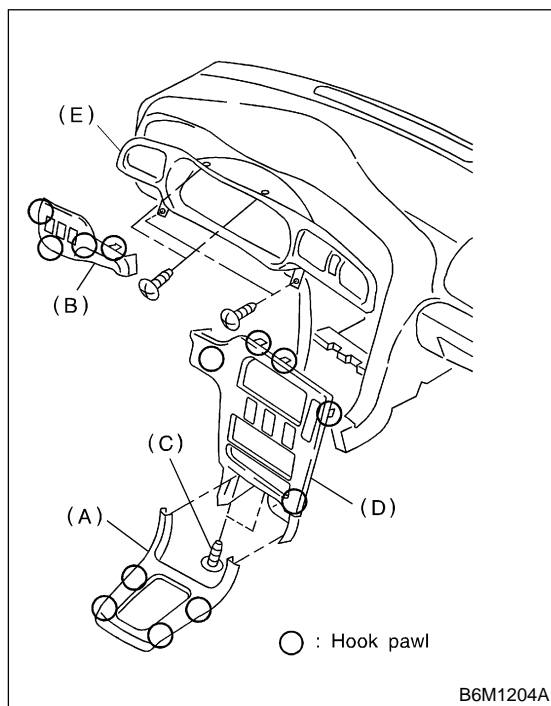

- 6) Remove screws of combination meter to pull out the meter toward you.
- 7) Remove connector in the upper area of combination meter to remove meter.

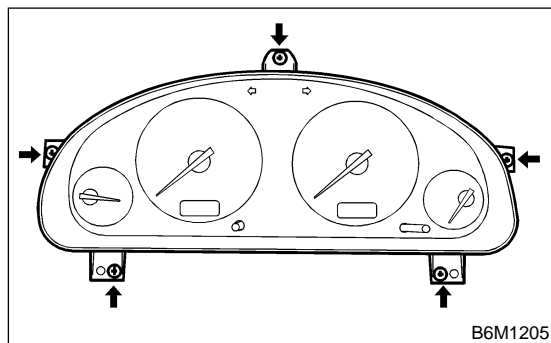

CAUTION:

- Be careful not to damage meter or instrument panel.
- Pay particular attention to avoid damaging the meter glass.

B: INSTALLATION

S907335A11

Install in the reverse order of removal.

CAUTION:

- Make sure that electrical connector is connected securely.
- Make sure that each meter operates normally.

C: DISASSEMBLY

S907335A06

CAUTION:

Use gloves to avoid damage and getting fingerprints on the glass surface and meter surfaces.

- 1) Disengage claw (F) to remove case (B) from back cover (A).
- 2) Disengage claw (G) to remove meter glass (E), reflector (D), and window plate (C) from inner case.

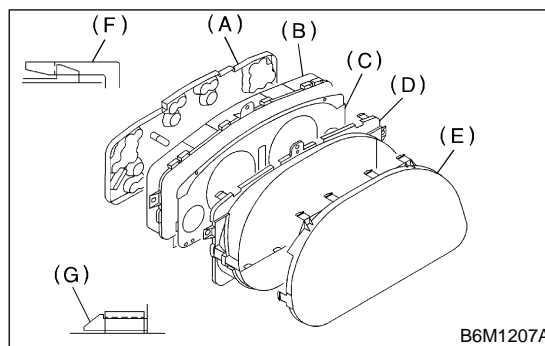

- 3) Pull up claw (A) in portion (B) of circuit plate (C) with combination pliers. Push out speedometer assembly (D) and tachometer assembly (E) using hole (F).
- 4) Pull up claw in the center of circuit plate (C), and remove circuit plate from case (G).

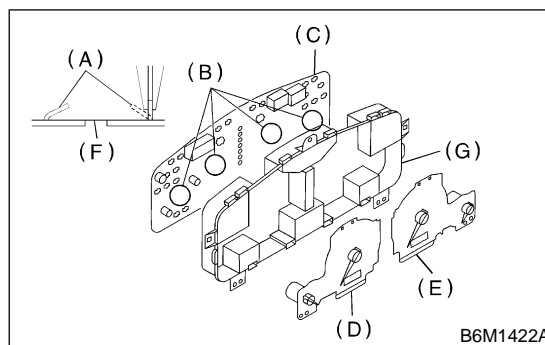

COMBINATION METER ASSEMBLY

Instrumentation/Driver Info

1. BULB REPLACEMENT S907335A0601

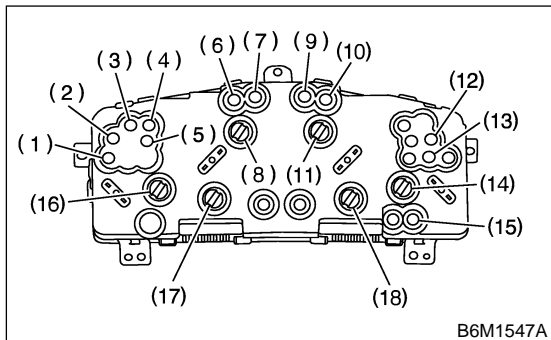

- (1) FWD
- (2) AT OIL TEMP.
- (3) Oil pressure
- (4) Check engine
- (5) Charge
- (6) HI-beam
- (7) Turn RH
- (8) Tachometer
- (9) Turn LH
- (10) Brake
- (11) Speedometer
- (12) Airbag
- (13) ABS
- (14) Speedometer and fuel gauge
- (15) Low fuel
- (16) Tachometer and temperature gauge
- (17) LCD (Clock or clock and outside temperature indicator)
- (18) LCD (Odometer and trip meter)

D: ASSEMBLY S907335A02

Assemble in the reverse order of disassembly.