

## 5. Back-up Light System S914414

### A: SCHEMATIC S914414A21

#### 1. BACK-UP LIGHT S914414A2101

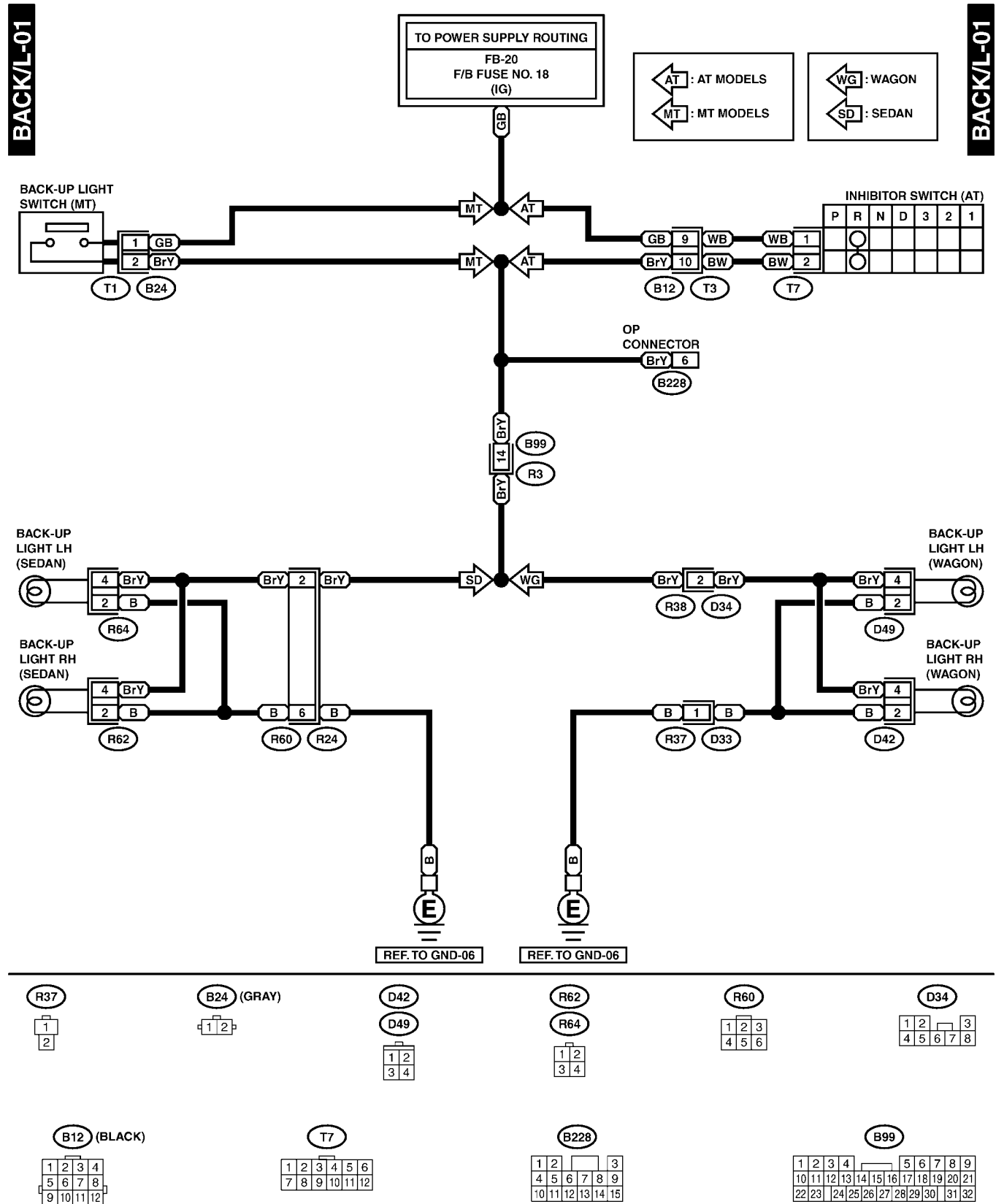

# BACK-UP LIGHT SYSTEM

Lighting System

## B: INSPECTION S914414A10

### 1. BACK-UP LIGHT SWITCH (M/T) S914414A1001

Check continuity between terminals.

Switch position	Tester connection	Specified condition
When shift lever is set in reverse position	1 - 2	Continuity
Other positions		No continuity

### 2. INHIBITOR SWITCH (A/T) S914414A1002

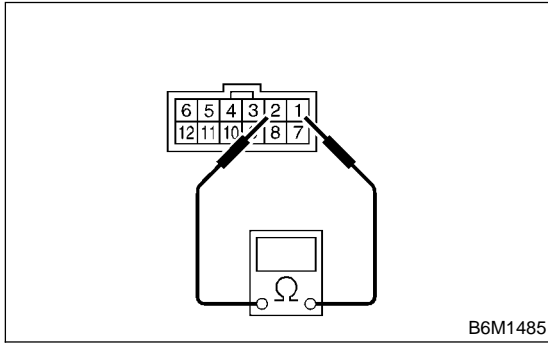

Check continuity between terminals.

Switch position	Tester connection	Specified condition
When select lever is set in "R" position	1 - 2	Continuity
Other positions		No continuity