

FRONT SEAT

Seats

2. Front Seat S908343

A: REMOVAL S908343A18

1. STANDARD S908343A1801

- 1) Disconnect battery (-) terminal.
- 2) While pressing headrest lock button, remove headrest.

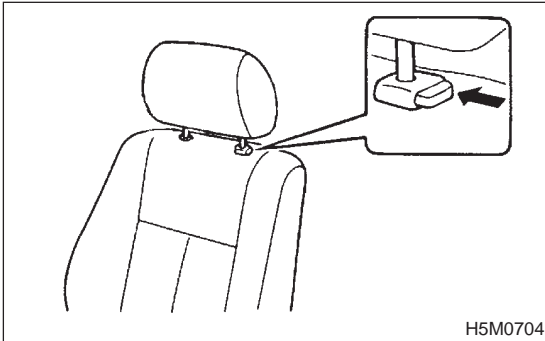

- 3) Tilt forward backrest.
- 4) Move seat to full front end.
- 5) Remove bolt cover at rear end of slide rail.

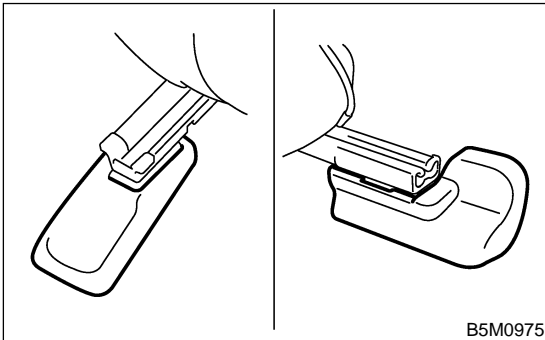

- 6) Disconnect side airbag connector under the seat. (Side airbag equipped vehicle)
- 7) Disconnect connectors of seat heater and seat belt warning. (Seat heater equipped vehicle)
- 8) Remove two bolts at rear side of seat rail.

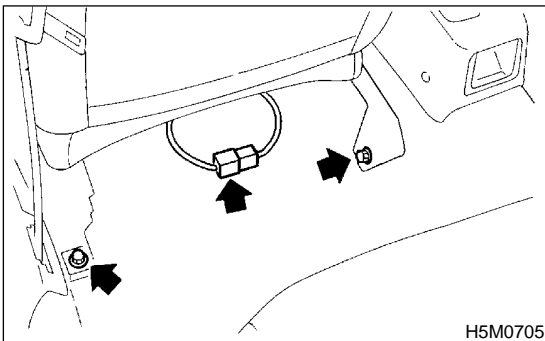

- 9) Move seat to full rear end.

- 10) Remove two bolts at front side of seat rail.

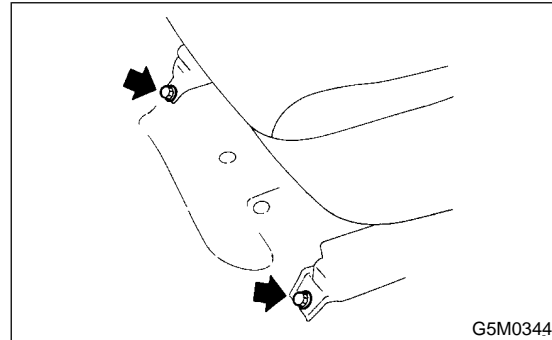

- 11) Remove front seat from vehicle.

CAUTION:

When removing seat from vehicle, take care not to damage body, seat, or trim.

2. POWER S908343A1802

- 1) While pressing headrest lock button, remove headrest.

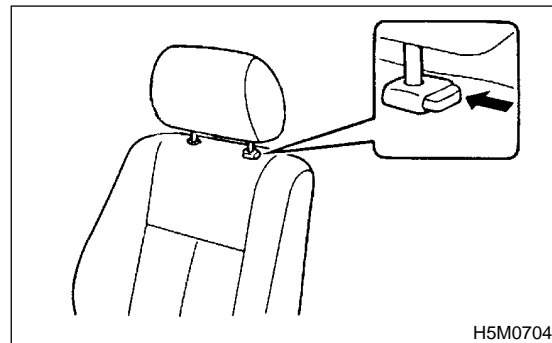

- 2) Tilt forward backrest.
- 3) Move seat to full front end.
- 4) Remove bolt cover at rear end of slide rail.

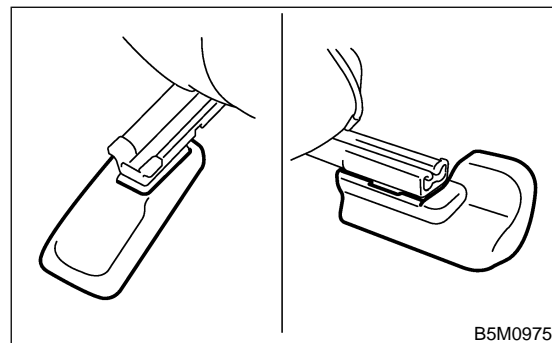

- 5) Remove two bolts at rear side of seat rail.

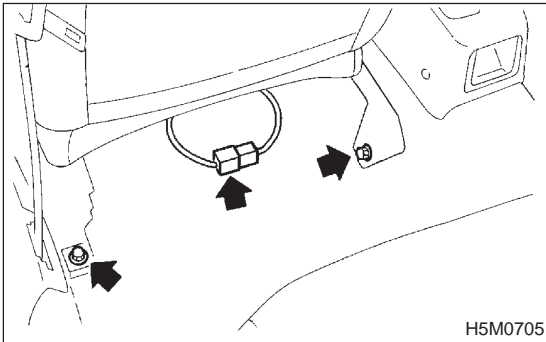

- 6) Move seat to full rear end.
7) Remove two bolts at front side of seat rail.

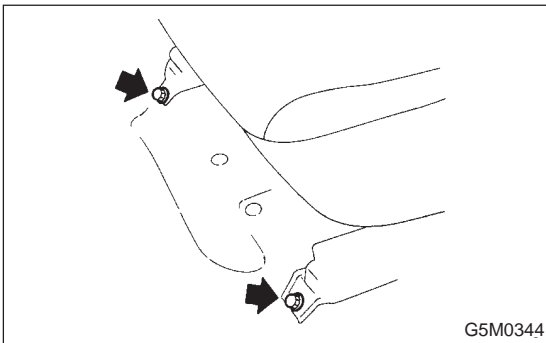

- 8) Disconnect battery (-) terminal.

CAUTION:

- Wait for 20 seconds or more after disconnecting the battery
- The air bag system has a backup power source. The air bag might deploy if you do not wait for 20 seconds or more before starting.

- 9) Disconnect side airbag connector under the seat. (Side airbag equipped vehicle)
10) Disconnect connectors of seat heater and seat belt warning. (Seat heater equipped vehicle)

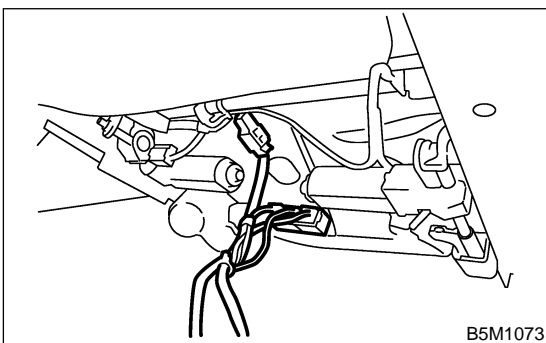

- 11) Remove front seat from vehicle.

CAUTION:

When removing seat from vehicle, take care not to damage body, seat, or trim.

B: INSTALLATION S908343A11

1. STANDARD S908343A1101

- 1) Install in the reverse order of removal.
- 2) Place slide rail rear inner on location bolts.

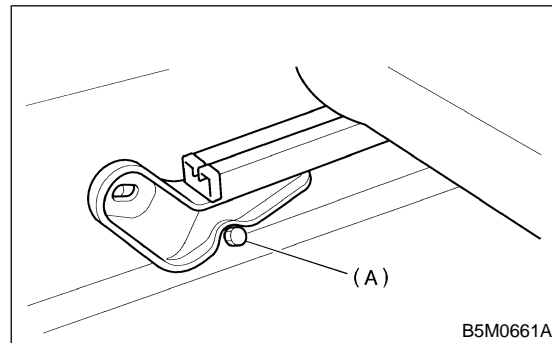

- 3) Tighten the four bolts of slide rail.

CAUTION:

Confirm that seat can move smoothly and be locked securely at any position.

2. POWER S908343A1102

- 1) Install in the reverse order of removal.
- 2) Place slide rail rear inner on location bolts.

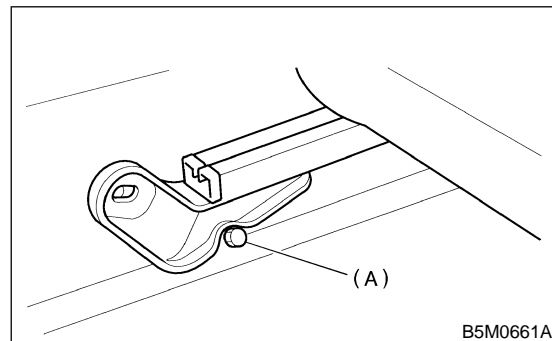

- 3) Tighten the four bolts of slide rail.

CAUTION:

Confirm that seat can move smoothly.

FRONT SEAT

Seats

C: DISASSEMBLY S908343A06

1. STANDARD S908343A0601

- 1) Remove seats from vehicle. <Ref. to SE-6 REMOVAL, Front Seat.>
- 2) Remove lumber lever cover.

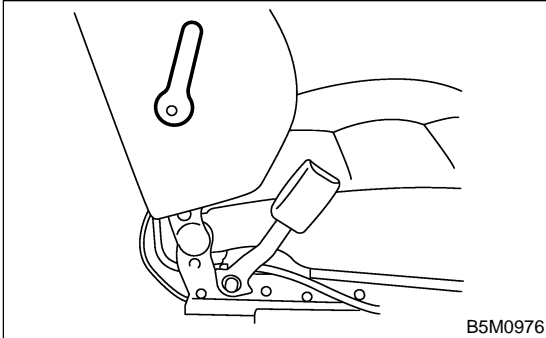

- 3) Remove hook at bottom, and then remove seat back board.

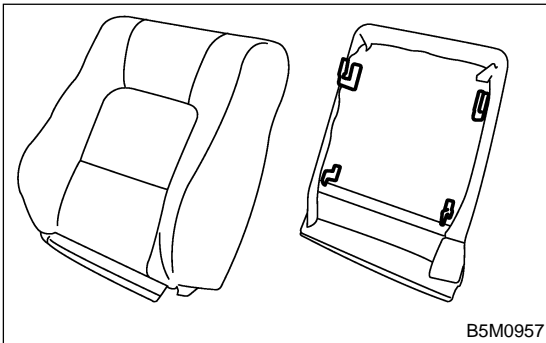

- 4) Remove hook on back side of seat, and remove hog rings using a plier.

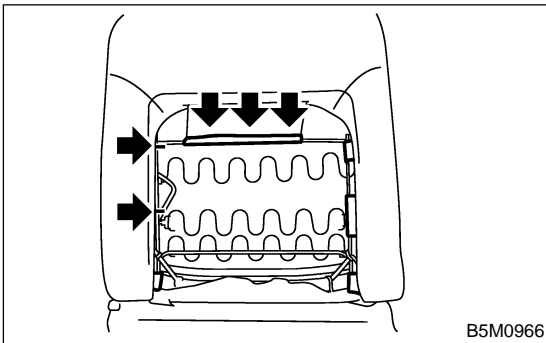

- 5) Remove clamp of side airbag wire harness. (Side airbag equipped vehicle)

- 6) Remove clamp of seat heater wire harness. (Seat heater equipped vehicle)

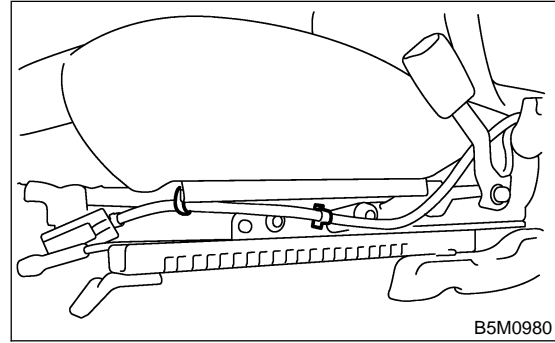

- 7) Turn cover and cushion, and remove the two bolts from hinge.

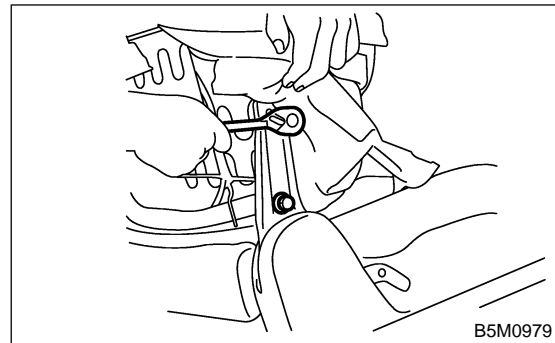

- 8) Remove hinge screw cover and screws, and remove seat back from hinge.

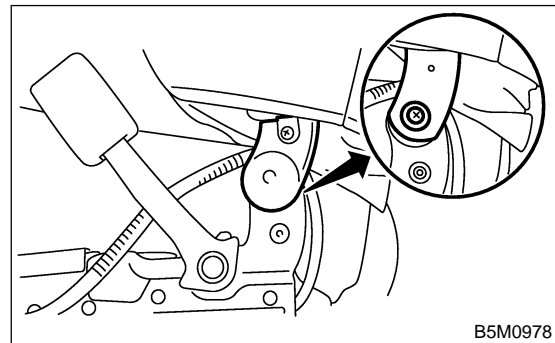

- 9) While picking up tip with a plier, remove head-rest lock bushing.

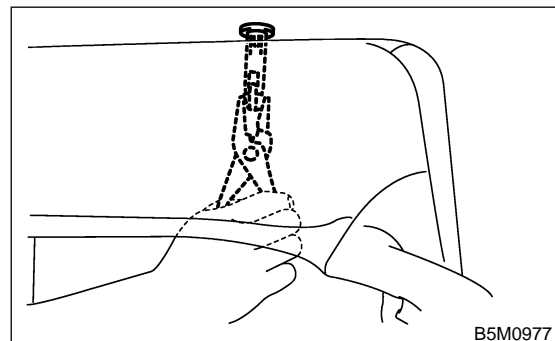

10) Remove hog ring on front face of seat.

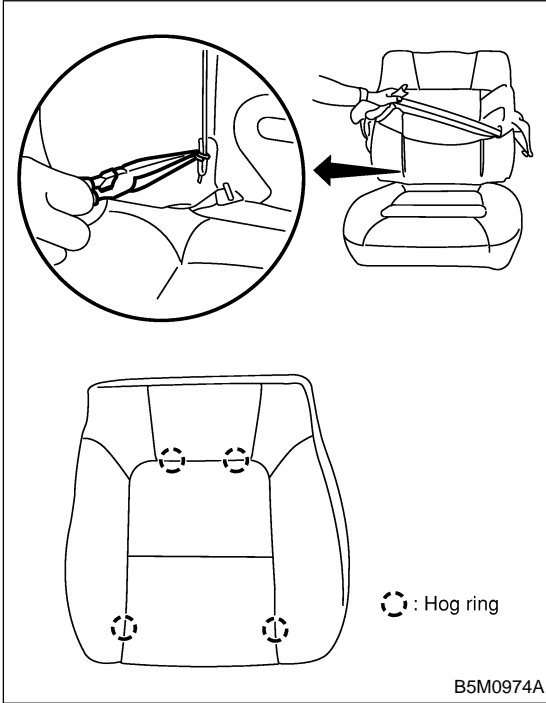

Side airbag equipped vehicle:

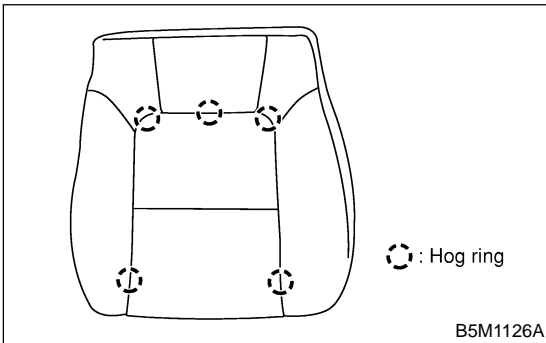

11) Remove hog rings, and then remove seat heater. (Seat heater equipped vehicle)

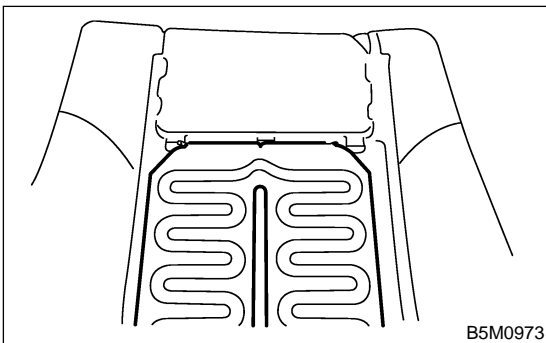

12) Remove seat cover.

13) Remove backrest pad.

14) Remove clamp of airbag wire harness on back side of seat. (Side airbag equipped vehicle)

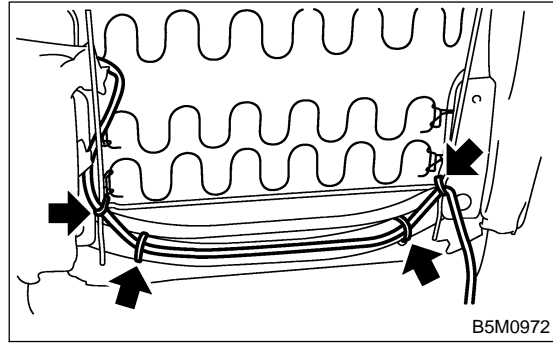

15) Remove the two cap nuts, and then remove side airbag module assembly. (Side airbag equipped vehicle)

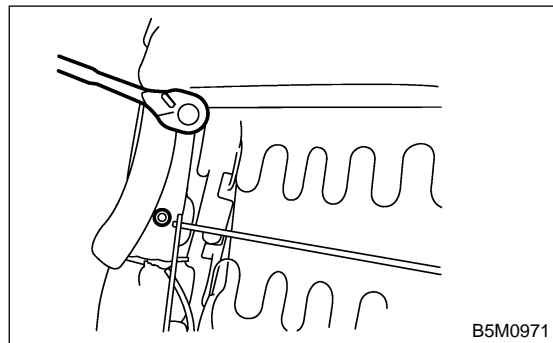

16) Remove reclining cover and hinge cover. (Non-tilt type vehicle)

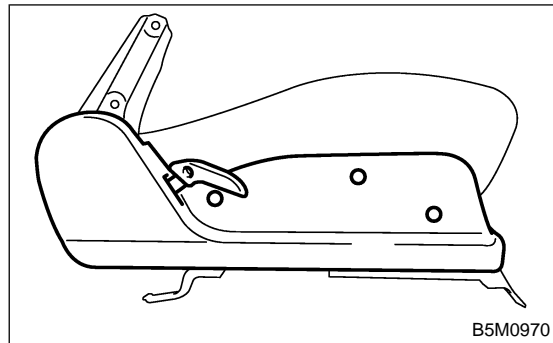

17) Remove the 4 bolts of seat hinge assembly, and then remove seat cushion. Tilt type vehicle:

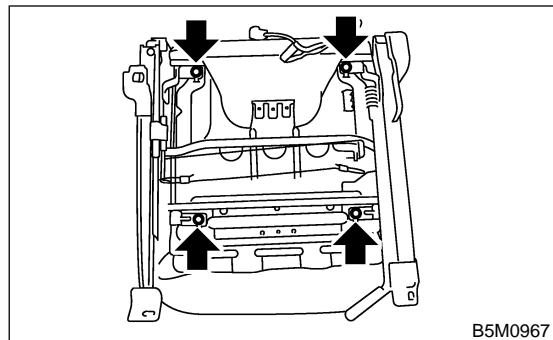

FRONT SEAT

Seats

Non-tilt type vehicle:

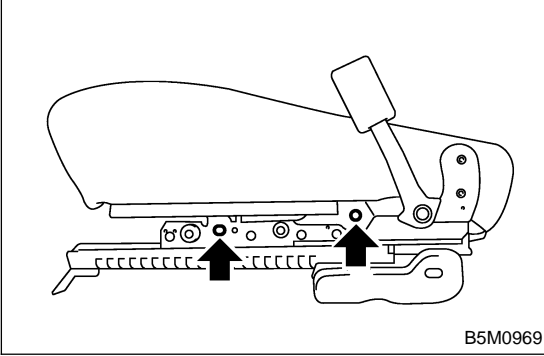
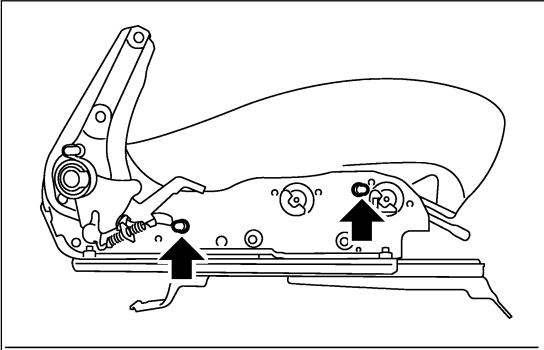

B5M0969

18) Remove hook clips on back side of seat cushion, and remove wire rings.

19) Remove clamp of seat heater wire harness. (Seat heater equipped vehicle)

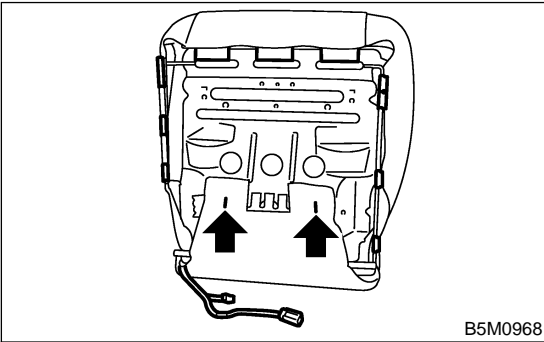

B5M0968

20) Remove hog rings.

Tilt type vehicle:

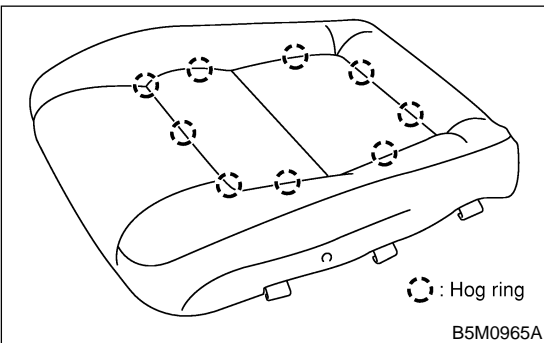

B5M0965A

Non-tilt type vehicle:

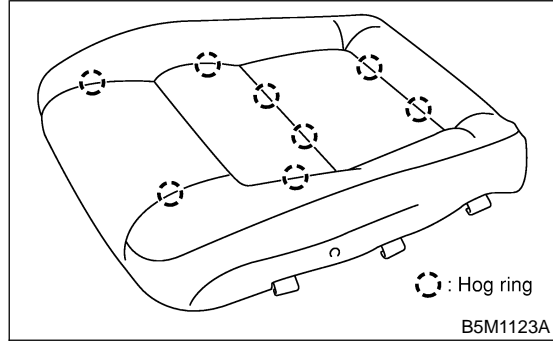

B5M1123A

Leather type vehicle:

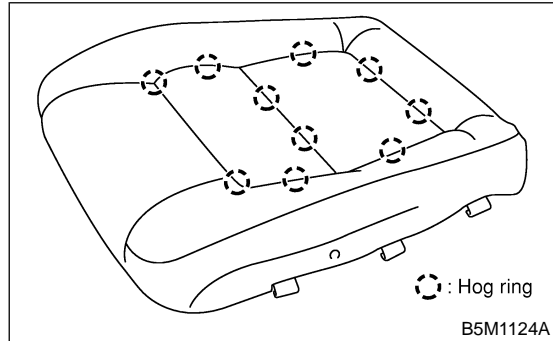

B5M1124A

21) Remove cushion cover.

22) Remove cushion pad.

23) Remove clip pins, and remove seat lifter lever.

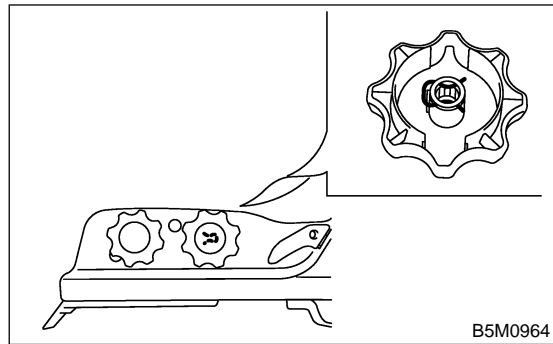

B5M0964

24) Remove reclining lever cover.

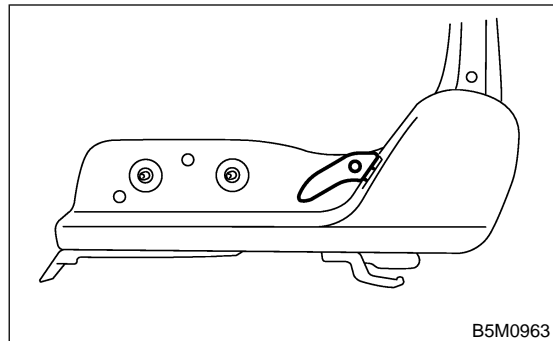

B5M0963

25) Remove hinge cover cap and screws.

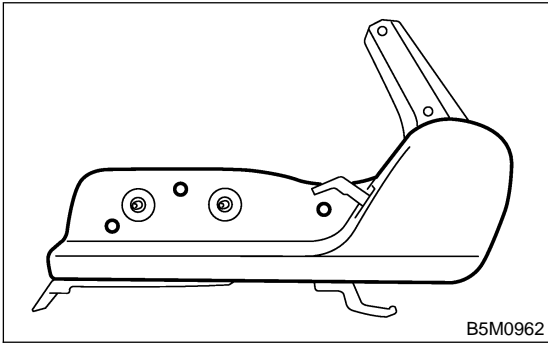

26) Remove seat hinge cover and hinge spring cover.

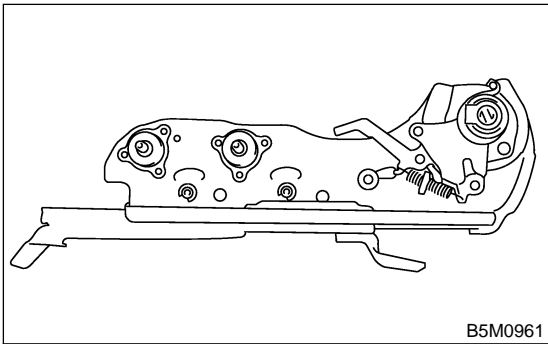

27) Remove 2 bolts, and then remove slide rail.

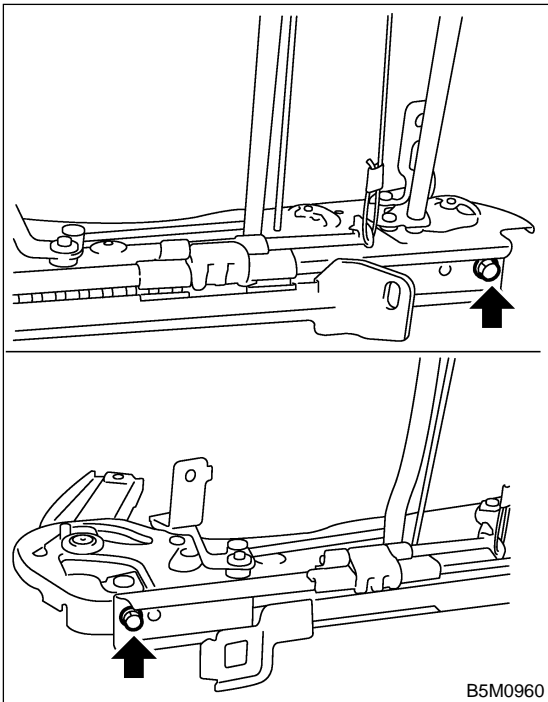

28) Remove 4 screws, and then remove hinge. (Non-tilt type vehicle)

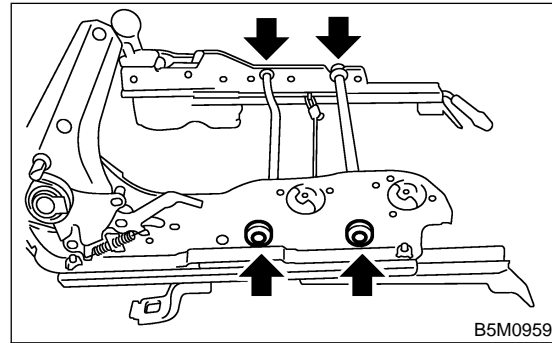

29) Remove 2 bolts, and then remove slide rail. (Non-tilt type vehicle)

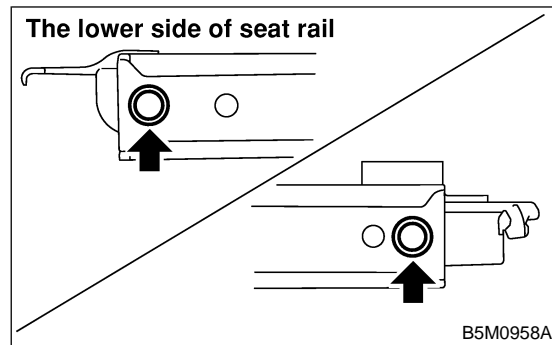

30) Remove connecting wire.

2. POWER S908343A0602

- 1) Remove seats from vehicle. <Ref. to SE-6 REMOVAL, Front Seat.>
- 2) Remove lumbar lever cover.

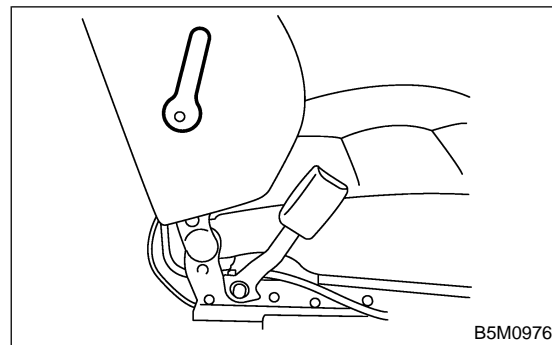

FRONT SEAT

Seats

3) Remove hook at bottom, and then remove seat back board.

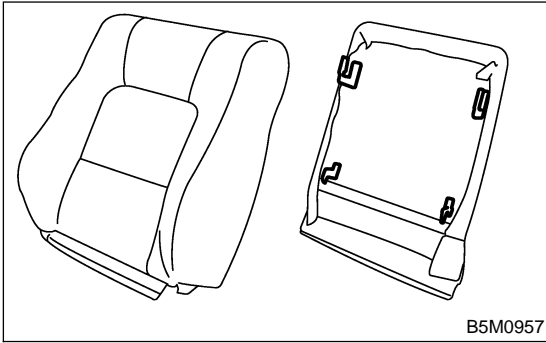

8) Remove hinge screw cover and screws, and remove seat back from hinge.

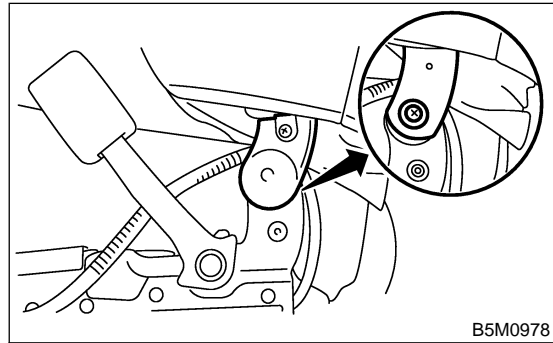

4) Remove hook on back side of seat, and remove wire rings using a plier.

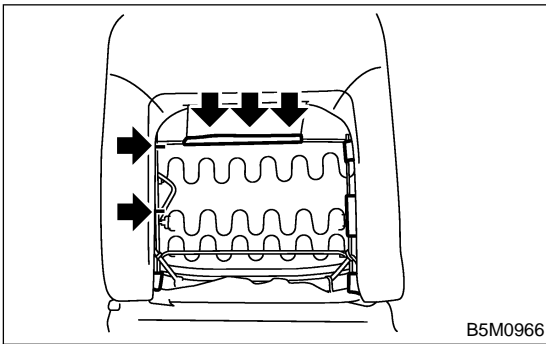

9) While picking up tip with a plier, remove head-rest lock bushing.

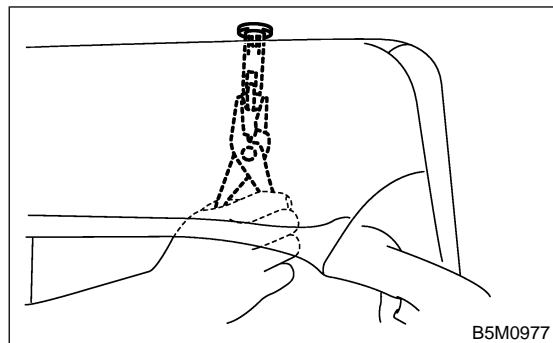

5) Remove clamp of side airbag wire harness. (Side airbag equipped vehicle)

6) Remove clamp of seat heater wire harness. (Seat heater equipped vehicle)

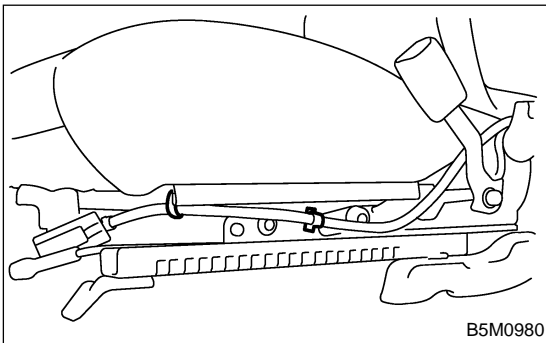

10) Remove wire ring on front face of seat.

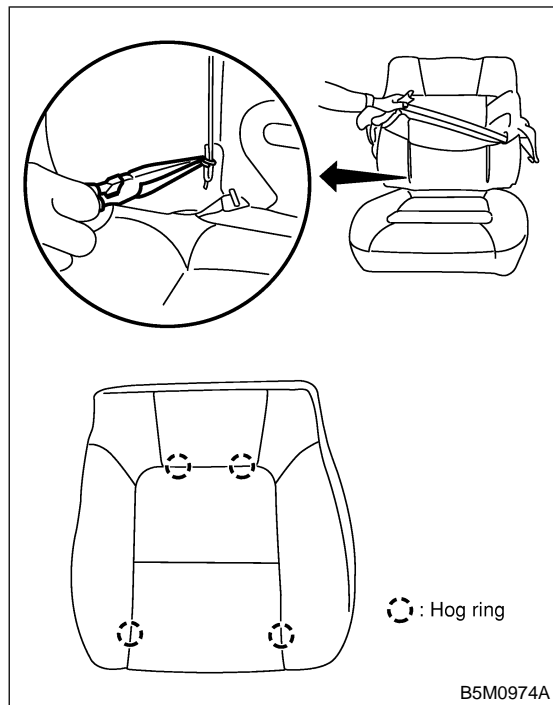

7) Turn cover and cushion, and remove the two bolts from hinge.

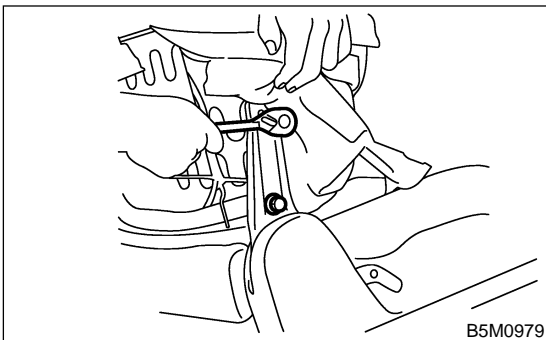

Side airbag equipped vehicle:

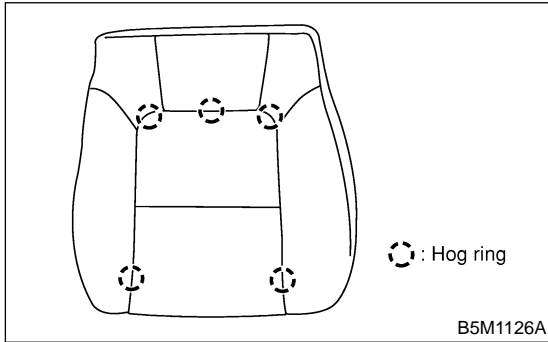

11) Remove wire rings, and then remove seat heater. (Seat heater equipped vehicle)

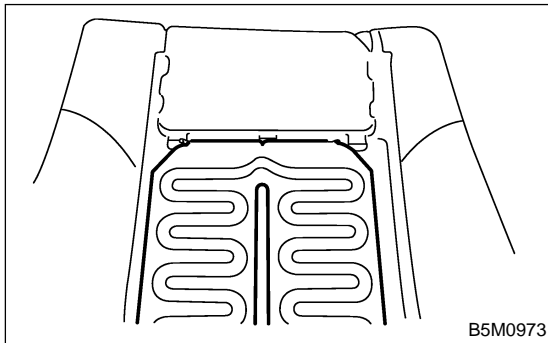

12) Remove seat cover.

13) Remove backrest pad.

14) Remove clamp of airbag wire harness on back side of seat. (Side airbag equipped vehicle)

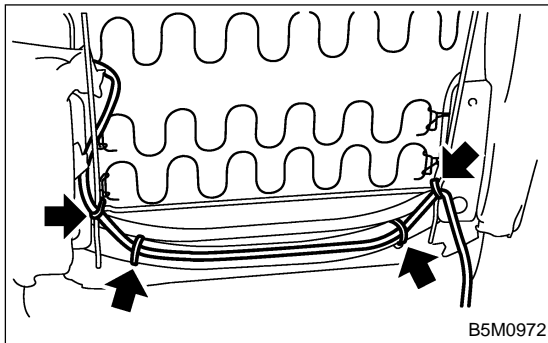

15) Remove the two cap nuts, and then remove side airbag module assembly. (Side airbag equipped vehicle)

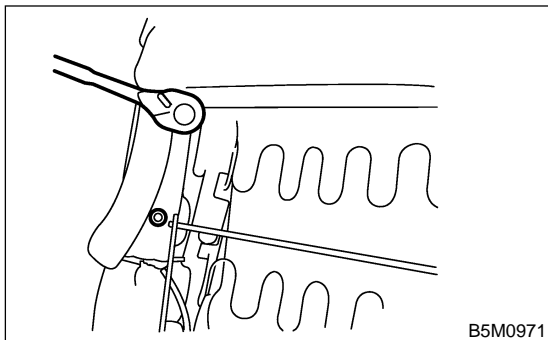

16) Remove the 4 bolts of seat hinge assembly, and then remove seat cushion.

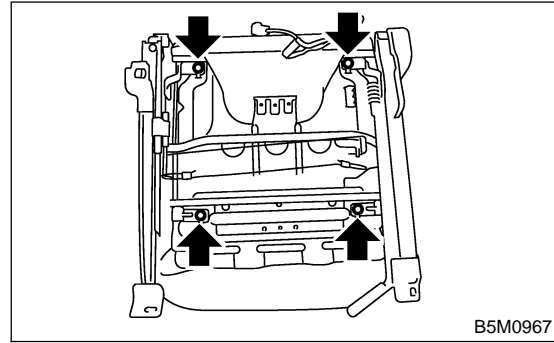

17) Remove hook clips on back side of seat cushion, and remove wire rings.

18) Remove clamp of seat heater wire harness. (Seat heater equipped vehicle)

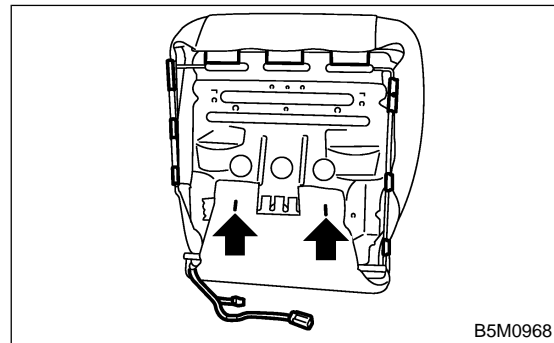

19) Remove wire rings.

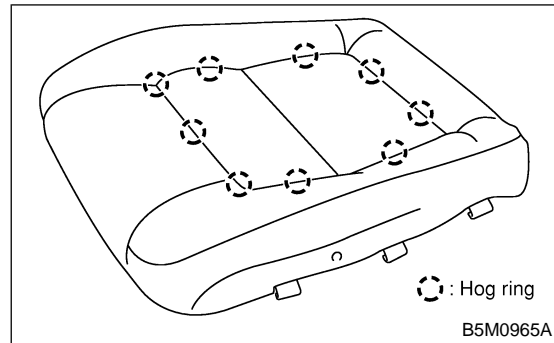

Leather type vehicle:

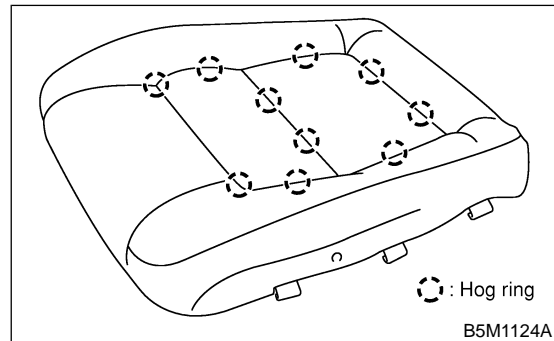

20) Remove cushion cover.

21) Remove cushion pad.

FRONT SEAT

Seats

22) Remove the screw and then remove the cover.

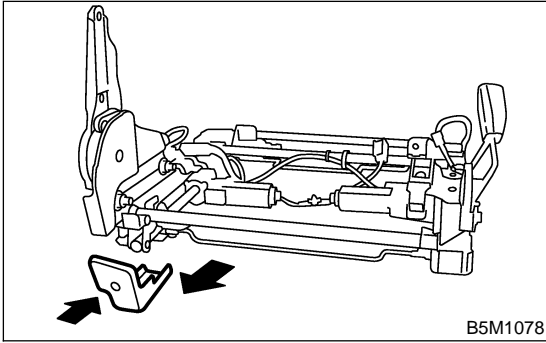

23) 8-way power:
Remove the screw, disconnect the seat switch connector on the underside of the cover, and remove the hinge cover.

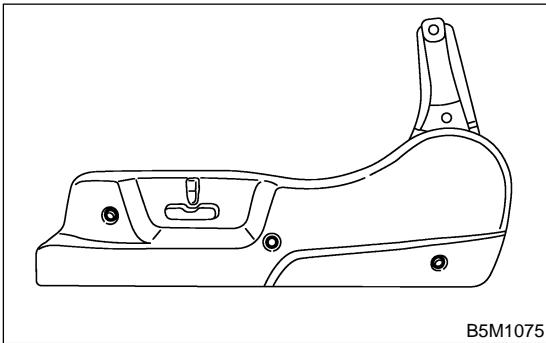

6-way power:
Remove the reclining lever cover and screw, disconnect the seat switch connector on the underside of the cover, and remove the hinge cover.

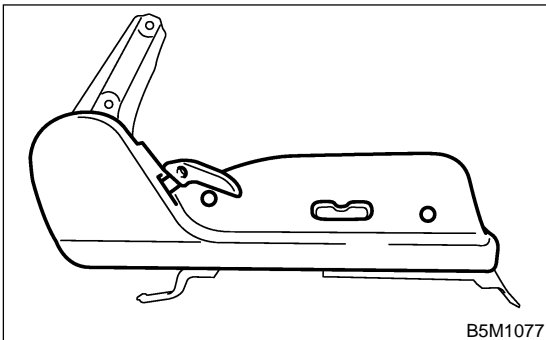

24) Remove the cover on the underside of the seat hinge, remove the two bolts, and remove the seat hinge.

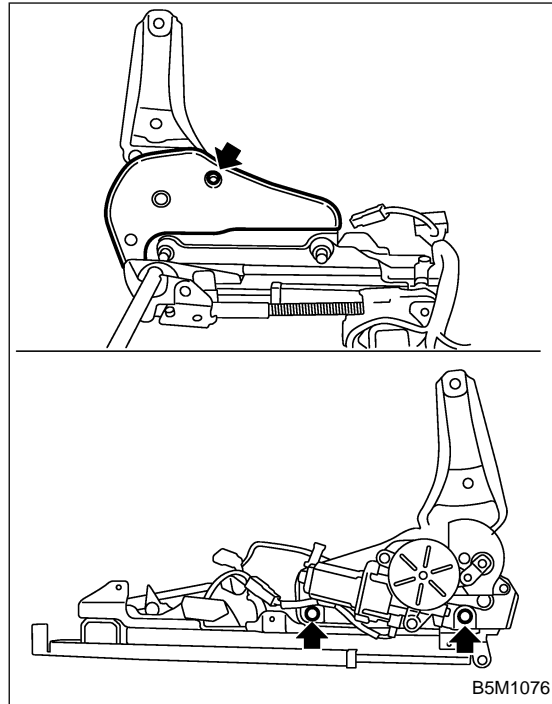

D: ASSEMBLY S908343A02

1. STANDARD S908343A0201

1) Assemble in the reverse order of disassembly.

NOTE:

- Do not contaminate or damage cover.
- While installing hog rings, prevent seat from getting wrinkled.

2) Attach seat cover end hole to hinge inner. (Only non-tilt type standard seat)

2. POWER S908343A0202

1) Assemble in the reverse order of disassembly.

NOTE:

- Do not contaminate or damage cover.
- While installing hog rings, prevent seat from getting wrinkled.
- Make sure the connector is firmly connected.
- Make sure the wire harness is not pinched.

2) Attach seat cover end hole to hinge inner. (Only non-tilt type standard seat)