

# KEYLESS ENTRY SYSTEM

Security and Locks

## 3. Keyless Entry System S909345

### A: SCHEMATIC S909345A21

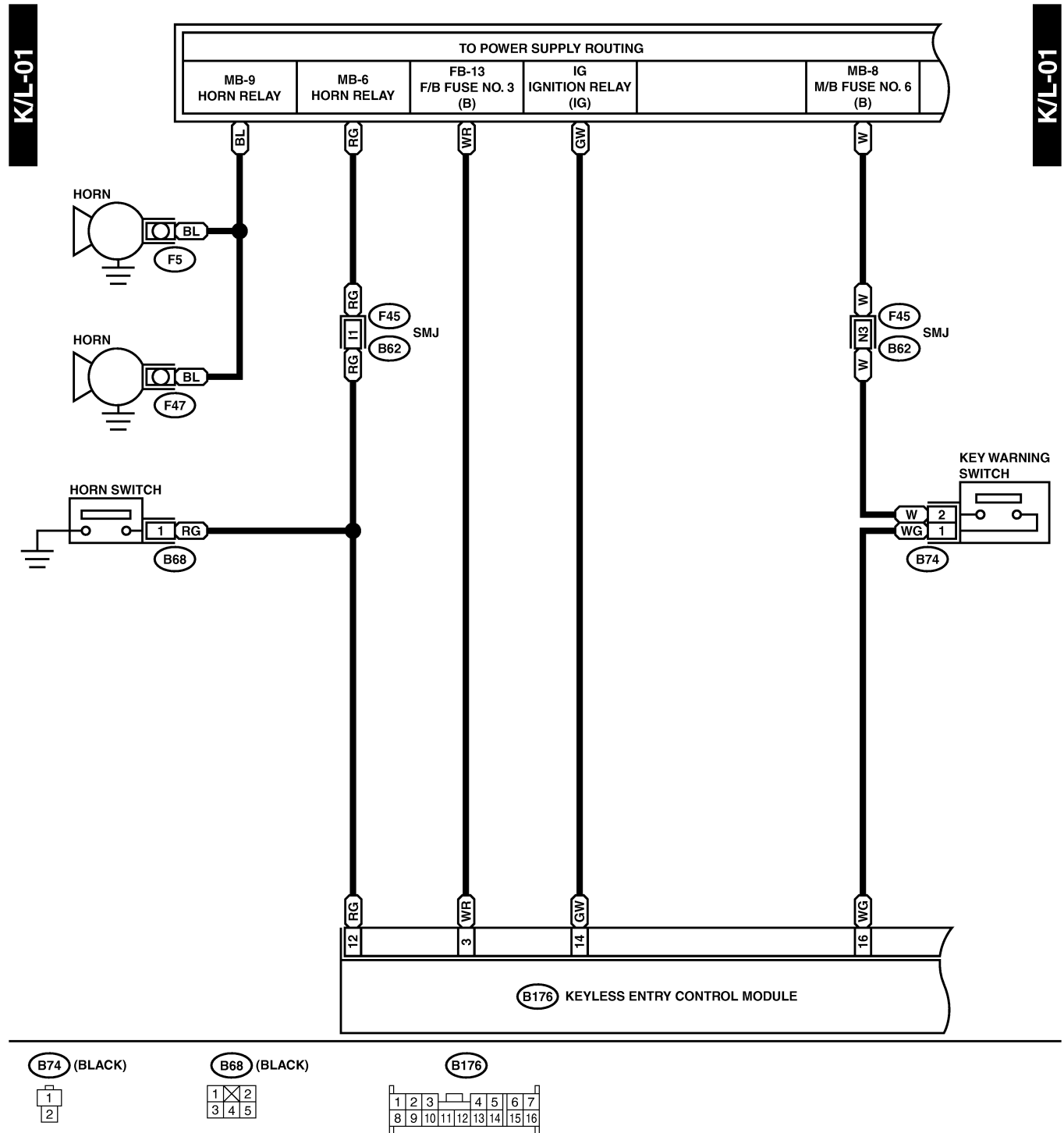

# KEYLESS ENTRY SYSTEM

Security and Locks

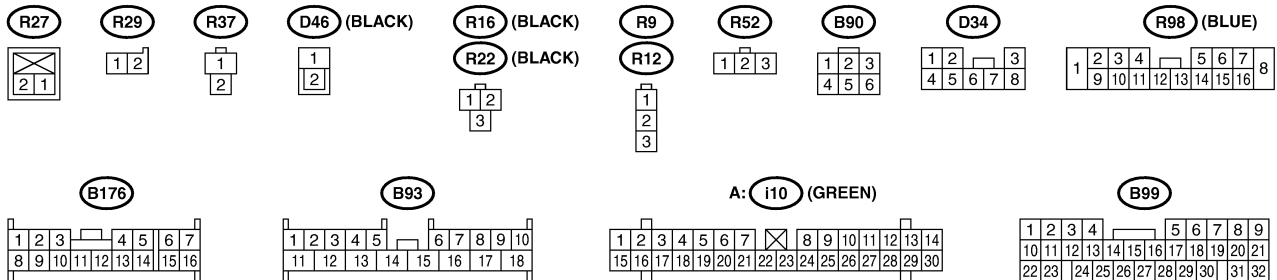
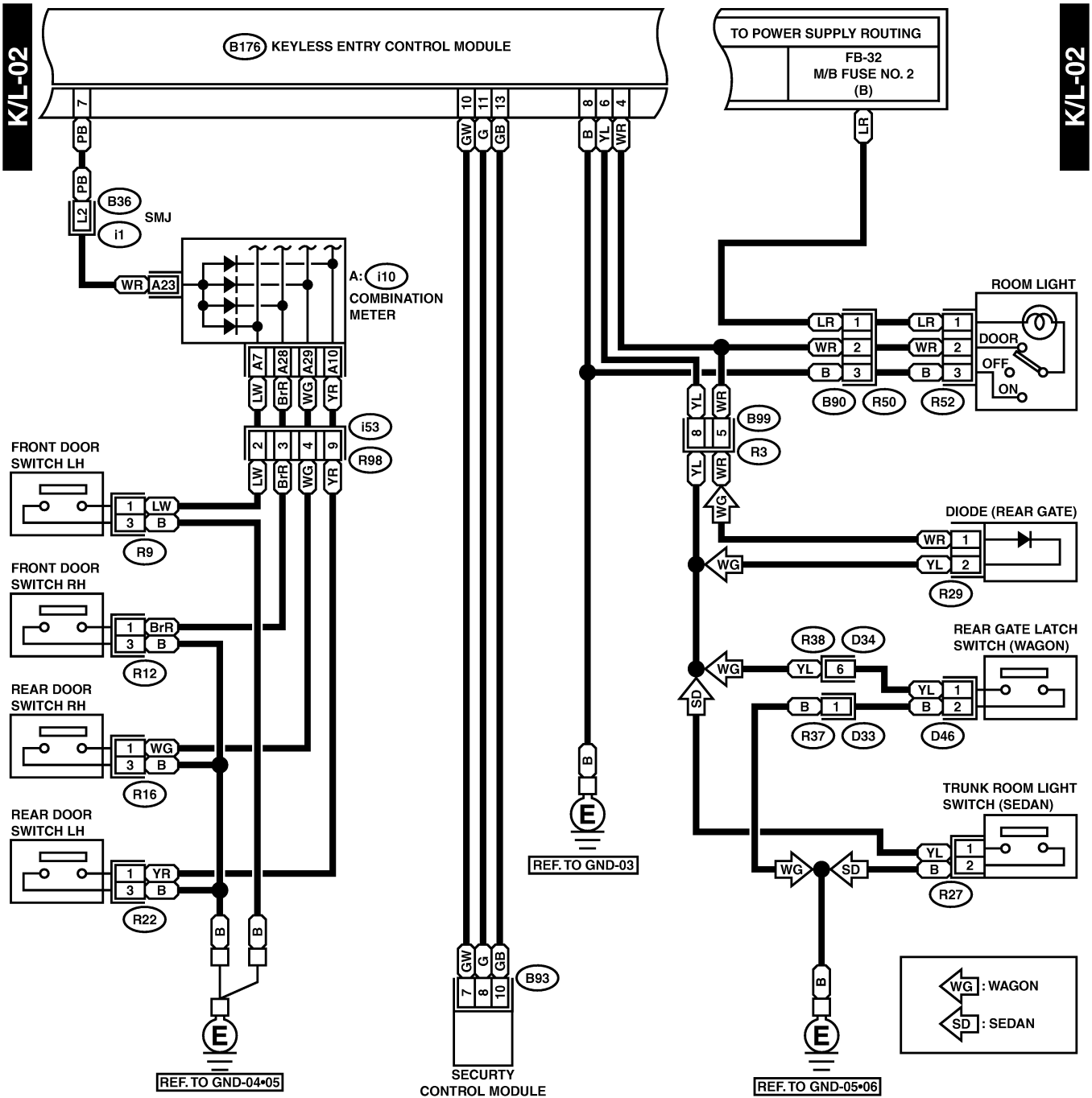

BU77-20B

SL-15

# KEYLESS ENTRY SYSTEM

Security and Locks

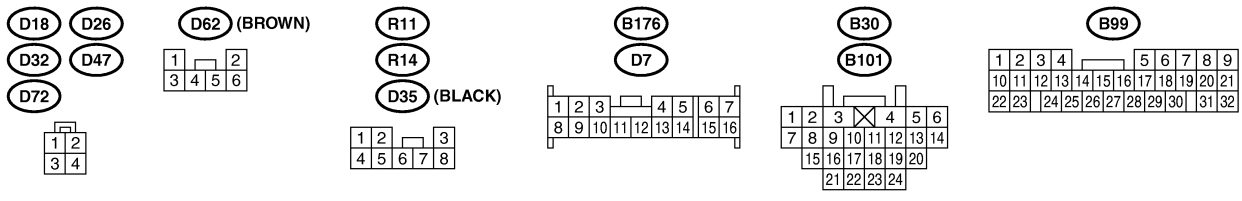
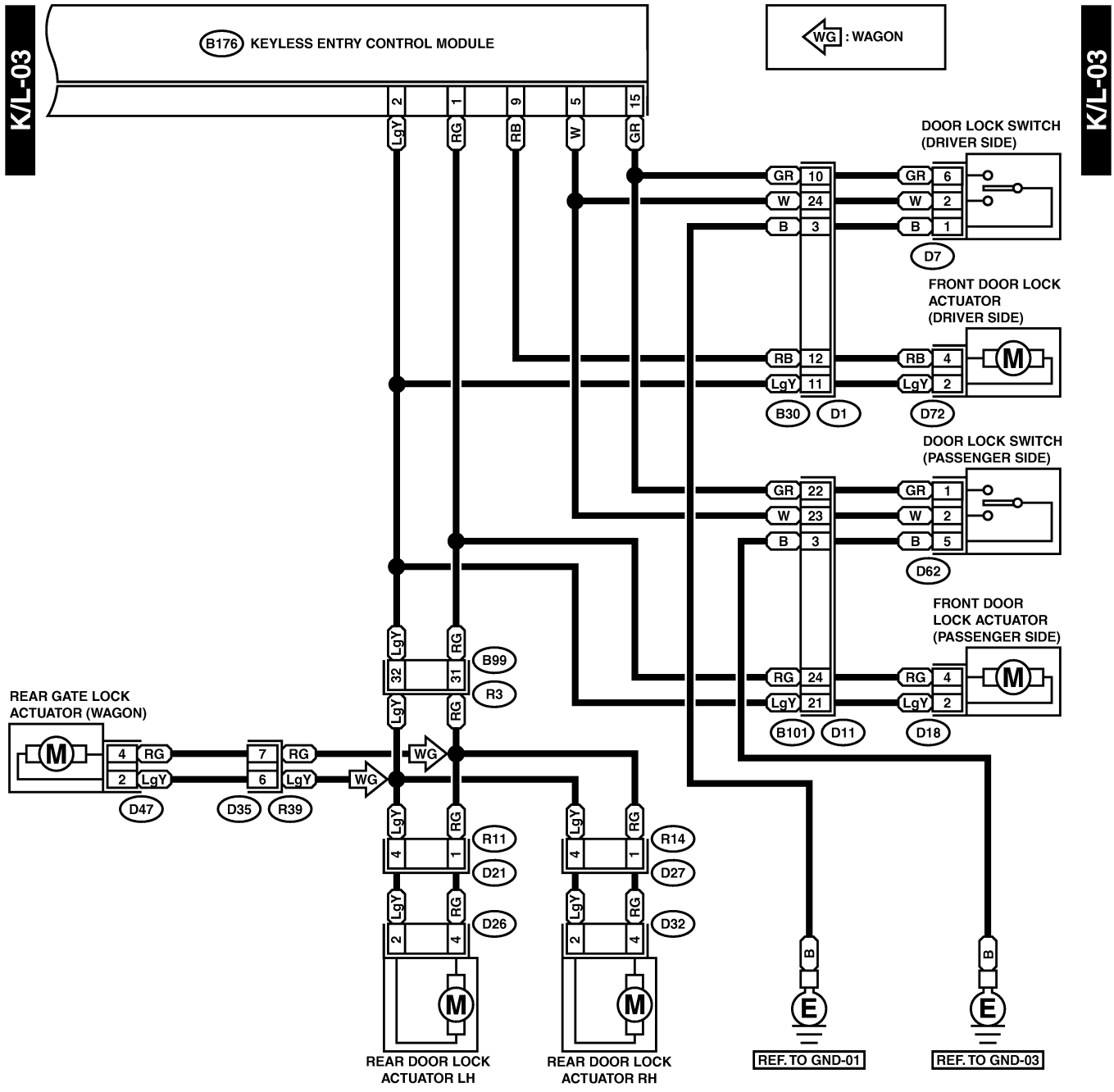

BU77-20C

## B: ELECTRICAL SPECIFICATION

S909345A08

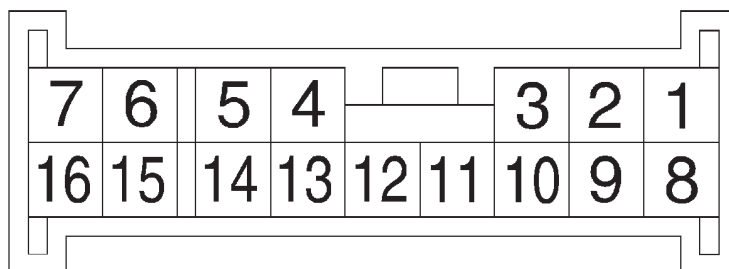

B6M0957

Content	Terminal No.	Measuring condition
Door and rear gate lock actuator (Except driver side)	1 (OUTPUT)	Battery voltage is present when pressing the transmitter UNLOCK/DISARM button two times.
Door and rear gate lock actuator	2 (OUTPUT)	Battery voltage is present when pressing the transmitter LOCK/ARM button one time.
Power supply (Back-up)	3	Battery voltage is constantly present.
Room light	4 (OUTPUT)	0 V is present when pressing the transmitter UNLOCK/DISARM button one time.
Door lock switch	5 (INPUT)	0 V is present when operating the door lock switch.
Trunk room light switch (Sedan), rear gate latch switch (Wagon)	6 (INPUT)	0 V is present when opening the trunk lid or rear gate.
Door switch	7 (INPUT)	0 V is present when any door is open.
Ground	8	—
Door lock actuator (Driver side)	9 (OUTPUT)	Battery voltage is present when pressing the transmitter UNLOCK/DISARM button one time.
Security control module	10	—
Security control module	11	—
Horn relay	12 (OUTPUT)	0 V is present when pressing the transmitter UNLOCK/DISARM or LOCK/ARM button.
Security control module	13	—
Ignition switch (ON)	14 (INPUT)	Battery voltage is present when ignition switch is turned ON.
Door unlock switch	15 (INPUT)	0 V is present when operating the door lock switch.
Key warning switch	16 (INPUT)	Battery voltage is present when inserting the key into the ignition switch.

# KEYLESS ENTRY SYSTEM

Security and Locks

## C: INSPECTION S909345A10

### 1. SYMPTOM CHART S909345A1001

Symptom	Repair order	Reference
None of the functions of the keyless entry system operate.	1. Check the transmitter battery and function.	<Ref. to SL-20 CHECK TRANSMITTER BATTERY AND FUNCTION, INSPECTION, Keyless Entry System.>
	2. Check the fuse.	<Ref. to SL-21 CHECK FUSE, INSPECTION, Keyless Entry System.>
	3. Check the keyless entry control module power supply and ground circuit.	<Ref. to SL-21 CHECK POWER SUPPLY AND GROUND CIRCUIT, INSPECTION, Keyless Entry system.>
	4. Replace the keyless entry control module.	<Ref. to SL-54 Keyless Entry Control Module.>
The transmitter cannot be programmed.	1. Check the transmitter battery and function.	<Ref. to SL-20 CHECK TRANSMITTER BATTERY AND FUNCTION, INSPECTION, Keyless Entry System.>
	2. Check the ignition switch circuit.	<Ref. to SL-21 CHECK IGNITION SWITCH CIRCUIT, INSPECTION, Keyless Entry System.>
	3. Check the door switch.	<Ref. to SL-21 CHECK DOOR SWITCH, INSPECTION, Keyless Entry System.>
	4. Replace the keyless entry control module.	<Ref. to SL-54 Keyless Entry Control Module.>
The door lock or unlock does not operate. NOTE: If the door lock control system does not operate when using the door lock switch, check the door lock control system. <Ref. to SL-11 INSPECTION, Door Lock Control System.>	1. Check the transmitter battery and function.	<Ref. to SL-20 CHECK TRANSMITTER BATTERY AND FUNCTION, INSPECTION, Keyless Entry System.>
	2. Check the key warning switch.	<Ref. to SL-22 CHECK KEY WARNING SWITCH, INSPECTION, Keyless Entry System.>
	3. Check the door switch.	<Ref. to SL-21 CHECK DOOR SWITCH, INSPECTION, Keyless Entry System.>
	4. Replace the keyless entry control module.	<Ref. to SL- 54 Keyless Entry Control Module.>
The panic alarm does not operate.	1. Check the transmitter battery and function.	<Ref. to SL-20 CHECK TRANSMITTER BATTERY AND FUNCTION, INSPECTION, Keyless Entry System.>
	2. Check the horn operation.	<Ref. to SL-23 CHECK HORN OPERATION, INSPECTION, Keyless Entry System.>
	3. Replace the keyless entry control module.	<Ref. to SL-54 Keyless Entry Control Module.>

# KEYLESS ENTRY SYSTEM

Security and Locks

Symptom	Repair order	Reference
The horn chirp does not operate.	1. Check the horn chirp function.	<Ref. to SL-20 CHECK HORN CHIRP SETTING, INSPECTION, Keyless Entry System.>
	2. Check the transmitter battery and function.	<Ref. to SL-20 CHECK TRANSMITTER BATTERY AND FUNCTION, INSPECTION, Keyless Entry System.>
	3. Check the key warning switch.	<Ref. to SL-22 CHECK KEY WARNING SWITCH, INSPECTION, Keyless Entry System.>
	4. Check the door switch.	<Ref. to SL-21 CHECK DOOR SWITCH, INSPECTION, Keyless Entry System.>
	5. Check the horn operation.	<Ref. to SL-23 CHECK HORN OPERATION, INSPECTION, Keyless Entry System.>
	6. Replace the keyless entry control module.	<Ref. to SL-54 Keyless Entry Control Module.>
The room light operation does not activate.	1. Check the transmitter battery and function.	<Ref. to SL-20 CHECK TRANSMITTER BATTERY AND FUNCTION, INSPECTION, Keyless Entry System.>
	2. Check the room light operation.	<Ref. to SL-23 CHECK ROOM LIGHT OPERATION, INSPECTION, Keyless Entry System.>
	3. Check the key warning switch.	<Ref. to SL-22 CHECK KEY WARNING SWITCH, INSPECTION, Keyless Entry System.>
	4. Check the door switch.	<Ref. to SL-21 CHECK DOOR SWITCH, INSPECTION, Keyless Entry System.>
	5. Replace the keyless entry control module.	<Ref. to SL-54 Keyless Entry Control Module.>
The door warning does not operate.	1. Check the transmitter battery and function.	<Ref. to SL-20 CHECK TRANSMITTER BATTERY AND FUNCTION, INSPECTION, Keyless Entry System.>
	2. Check the door switch.	<Ref. to SL-21 CHECK DOOR SWITCH, INSPECTION, Keyless Entry System.>
	3. Check the horn operation.	<Ref. to SL-23 CHECK HORN OPERATION, INSPECTION, Keyless Entry System.>
	4. Replace the keyless entry control module.	<Ref. to SL-54 Keyless Entry Control Module.>

# KEYLESS ENTRY SYSTEM

Security and Locks

## 2. CHECK TRANSMITTER BATTERY AND FUNCTION

S909345A1002

No.	Step	Check	Yes	No
1	<b>CHECK TRANSMITTER BATTERY.</b> 1) Remove the battery from the transmitter. <Ref. to SL-55 REMOVAL, Keyless Transmitter.> 2) Check the battery voltage. <Ref. to SL-55 INSPECTION, Keyless Transmitter.>	Is the voltage more than 2 V?	Go to step 2.	Replace the transmitter battery.
2	<b>CHECK LED OF TRANSMITTER.</b> 1) Press the LOCK/ARM or UNLOCK/DISARM button six times to synchronize with the keyless entry control module. 2) Press the LOCK/ARM button.	Does the LED blink one time?	Go to step 3.	Replace the transmitter. <Ref. to SL-55 REPLACEMENT, Keyless Transmitter.>
3	<b>CHECK LED OF TRANSMITTER.</b> Keep the LOCK/ARM button pressed.	Does the LED blink one time and then turn on?	Go to step 4.	Replace the transmitter. <Ref. to SL-55 REPLACEMENT, Keyless Transmitter.>
4	<b>CHECK LED OF TRANSMITTER.</b> Press the UNLOCK/DISARM button.	Does the LED blink one time?	Go to step 5.	Replace the transmitter. <Ref. to SL-55 REPLACEMENT, Keyless Transmitter.>
5	<b>CHECK LED OF TRANSMITTER.</b> Keep the UNLOCK/DISARM button pressed.	Does the LED blink two times?	The transmitter is OK.	Replace the transmitter. <Ref. to SL-55 REPLACEMENT, Keyless Transmitter.>

## 3. CHECK HORN CHIRP SETTING

S909345A1003

No.	Step	Check	Yes	No
1	<b>CHECK HORN CHIRP SETTING.</b> Check the current setting of the horn chirp. 1) Remove the key from the ignition switch. 2) Close all doors and the rear gate or trunk lid. 3) Press the LOCK/ARM or UNLOCK/DISARM button.	Does the horn signal chirp?	The horn chirp function is OK.	Go to step 2.
2	<b>CHECK HORN CHIRP SETTING.</b> 1) Press both the LOCK/ARM and UNLOCK/DISARM button for more than 2 seconds. 2) Press the LOCK/ARM or UNLOCK/DISARM button.	Does the horn signal chirp?	The horn chirp function is OK.	Check the transmitter function. <Ref. to SL-20 CHECK TRANSMITTER BATTERY AND FUNCTION, INSPECTION, Keyless Entry System.>

## 4. CHECK FUSE S909345A1004

No.	Step	Check	Yes	No
1	<b>CHECK FUSE.</b> Remove and visually check fuse No. 3 (in the fuse and relay box) and SBF-6 (in the main fuse box)	Is the fuse blown? (15 A and 30 A)	Replace the fuse with a new one.	Check power supply and ground circuit. <Ref. to SL-21 CHECK POWER SUPPLY AND GROUND CIRCUIT, INSPECTION, Keyless Entry system.>

## 5. CHECK POWER SUPPLY AND GROUND CIRCUIT S909345A1005

No.	Step	Check	Yes	No
1	<b>CHECK POWER SUPPLY.</b> 1) Disconnect the keyless entry control module harness connector. 2) Measure the voltage between the harness connector terminal and chassis ground. <b>Connector &amp; terminal</b> <b>(B176) No. 3 (+) — chassis ground (-):</b>	Is the voltage more than 10 V?	Go to step 2.	Check the harness for open circuits and shorts between the keyless entry control module and fuse.
2	<b>CHECK GROUND CIRCUIT.</b> Measure the resistance between the harness connector terminal and chassis ground. <b>Connector &amp; terminal</b> <b>(B176) No. 8 (+) — chassis ground (-):</b>	Is the resistance less than 10 Ω?	The power supply and ground circuit are OK.	Repair the harness.

## 6. CHECK IGNITION SWITCH CIRCUIT S909345A1006

No.	Step	Check	Yes	No
1	<b>CHECK IGNITION SWITCH SIGNAL.</b> 1) Disconnect the keyless entry control module harness connector. 2) Turn the ignition switch ON. 3) Measure the voltage between the harness connector terminal and chassis ground. <b>Connector &amp; terminal</b> <b>(B176) No. 14 (+) — chassis ground (-):</b>	Is the voltage more than 10 V?	The ignition switch circuit is OK.	Check the harness for open circuits and shorts between the keyless entry control module and ignition relay.

## 7. CHECK DOOR SWITCH S909345A1007

No.	Step	Check	Yes	No
1	<b>CHECK DOOR SWITCH CIRCUIT.</b> Measure the voltage between the keyless entry control module harness connector terminal and chassis ground. <b>Connector &amp; terminal</b> <b>Front and rear door:</b> <b>(B176) No. 7 (+) — chassis ground (-):</b> <b>Rear gate or trunk lid:</b> <b>(B176) No. 6 (+) — chassis ground (-):</b>	Is the voltage 0 V when each door, rear gate and trunk lid is opened?	Go to step 2.	Go to step 3.



# KEYLESS ENTRY SYSTEM

Security and Locks

No.	Step	Check	Yes	No
2	<p><b>CHECK DOOR SWITCH CIRCUIT.</b> Measure the voltage between the keyless entry control module harness connector terminal and chassis ground.</p> <p><b>Connector &amp; terminal</b> <b>Front and rear door:</b> <b>(B176) No. 7 (+) — chassis ground (-):</b> <b>Rear gate or trunk lid:</b> <b>(B176) No. 6 (+) — chassis ground (-):</b></p>	Is the voltage approx. 10 V when each door, rear gate and trunk lid is closed?	The door switch is OK.	Go to step 3.
3	<p><b>CHECK DOOR SWITCH.</b> 1) Disconnect the door switch harness connector. 2) Check the continuity between the door switch terminals.</p> <p><b>Terminal</b> <b>Front LH No. 1 — No. 3:</b> <b>Front RH No. 1 — No. 3:</b> <b>Rear LH No. 1 — No. 3:</b> <b>Rear RH No. 1 — No. 3:</b> <b>Rear gate No. 1 — No. 2:</b> <b>Trunk lid No. 1 — No. 2:</b></p>	Does continuity exist when the door switch is pushed?	Replace the door switch.	Go to step 4.
4	<p><b>CHECK DOOR SWITCH.</b> Check continuity between the door switch terminals.</p> <p><b>Terminal</b> <b>Front LH No. 1 — No. 3:</b> <b>Front RH No. 1 — No. 3:</b> <b>Rear LH No. 1 — No. 3:</b> <b>Rear RH No. 1 — No. 3:</b> <b>Rear gate No. 1 — No. 2:</b> <b>Trunk lid No. 1 — No. 2:</b></p>	Does continuity exist when the door switch is released?	Check the harness for open circuits and shorts between the keyless entry control module and door switch.	Replace the door switch.

## 8. CHECK KEY WARNING SWITCH S909345A1008

No.	Step	Check	Yes	No
1	<p><b>CHECK FUSE.</b> Remove and visually check fuse No. 6 (in the main fuse box).</p>	Is the fuse blown? (15A)	Replace the fuse with a new one.	Go to step 2.
2	<p><b>CHECK KEY WARNING SWITCH CIRCUIT.</b> 1) Disconnect the keyless entry control module harness connector. 2) Insert the key into the ignition switch. (LOCK position) 3) Measure the voltage between the harness connector terminal and chassis ground.</p> <p><b>Connector &amp; terminal</b> <b>(B176) No. 16 (+) — chassis ground (-):</b></p>	Is the voltage approx. 10 V?	Go to step 3.	Go to step 4.
3	<p><b>CHECK KEY WARNING SWITCH CIRCUIT.</b> 1) Remove the key from the ignition switch. 2) Measure the voltage between the harness connector terminal and chassis ground.</p> <p><b>Connector &amp; terminal</b> <b>(B176) No. 16 (+) — chassis ground (-):</b></p>	Is the voltage 0 V?	The key warning switch is OK.	Go to step 4.

# KEYLESS ENTRY SYSTEM

Security and Locks

No.	Step	Check	Yes	No
4	<b>CHECK KEY WARNING SWITCH.</b> 1) Disconnect the key warning switch harness connector. 2) Insert the key into the ignition switch. (LOCK position) 3) Check the continuity between the key warning switch terminals. <i>Terminal</i> <b>No. 1 — No. 2:</b>	Does continuity exist?	Go to step 5.	Replace key warning switch.
5	<b>CHECK KEY WARNING SWITCH.</b> 1) Remove the key from the ignition switch. 2) Check the continuity between the key warning switch terminals. <i>Terminal</i> <b>No. 1 — No. 2:</b>	Does continuity exist?	Replace key warning switch.	<b>Check the following:</b> <ul style="list-style-type: none"> <li>● Harness for open circuits and shorts between the key warning switch and fuse</li> <li>● Harness for open circuits and shorts between the keyless entry control module and key warning switch</li> </ul>

## 9. CHECK HORN OPERATION S909345A1009

No.	Step	Check	Yes	No
1	<b>CHECK HORN OPERATION.</b> Make sure the horn sounds when the horn switch is pushed.	Does the horn sound?	Go to step 2.	Check the horn circuit.
2	<b>CHECK HORN OPERATION.</b> 1) Disconnect the keyless entry control module harness connector. 2) Ground the harness connector terminal with a suitable wire. <i>Connector &amp; terminal</i> <b>(B176) No. 12 — chassis ground:</b>	Does the horn sound?	Replace the keyless entry control module.	Check the harness for open circuits and or shorts between the keyless entry control module and horn relay.

## 10. CHECK ROOM LIGHT OPERATION

S909345A1010

No.	Step	Check	Yes	No
1	<b>CHECK ROOM LIGHT OPERATION.</b> Make sure the room light illuminates when the room light switch is turned ON.	Does the room light illuminate?	Go to step 2.	Check the room light circuit.
2	<b>CHECK HARNESS BETWEEN ROOM LIGHT AND KEYLESS ENTRY CONTROL MODULE.</b> 1) Disconnect the keyless entry control module harness connector and room light harness connector. 2) Measure the resistance between the keyless entry control module harness connector terminal and the room light harness connector terminal. <i>Connector &amp; terminal</i> <b>(B176) No. 4 — (R52) No. 2:</b>	Is resistance less than 10 $\Omega$ ?	The room light operation circuit is OK.	Check the harness for open circuits and or shorts between the keyless entry control module and room light.