

# SECURITY CONTROL MODULE

Security and Locks

## 21. Security Control Module S909330

### A: REMOVAL S909330A18

- 1) Disconnect battery ground cable.
- 2) Remove front cover (A).
- 3) Remove screws (B) and then detach center panel (C) while disconnecting connector.

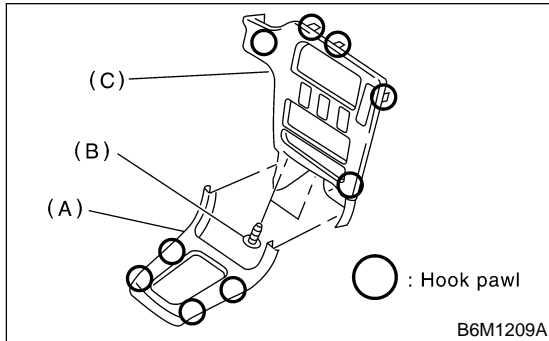

- 4) Remove two screws.

#### NOTE:

Before removing the screw, apply a few turns of butyl tape to the tip of the service tool. This prevents the screw from falling during removal.

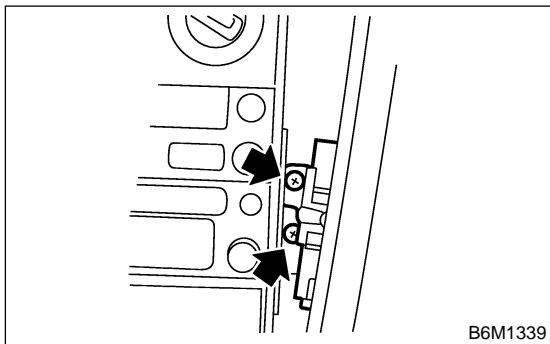

- 5) Remove radio and security control module together while disconnecting connector. <Ref. to ET-10 REMOVAL, Radio Body.>

### B: INSTALLATION S909330A11

Install in the reverse order of removal.

### C: INSPECTION S909330A10

#### 1. IMPACT SENSITIVITY TEST S909330A1001

- 1) Remove the key from the ignition switch.
- 2) Close all windows.
- 3) Close all doors and the rear gate or trunk lid.
- 4) Cover the hood with a blanket.
- 5) Press the LOCK/ARM button of the transmitter.
- 6) Confirm that the security indicator light blinks every 2 seconds.
- 7) Hit the center of the windshield with your palm and make sure the alarm operates.

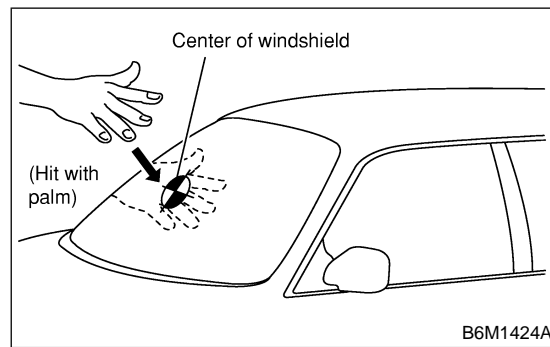

If NG, adjust the impact sensitivity. <Ref. to SL-50 ADJUSTMENT, Security Control Module.>

### D: ADJUSTMENT S909330A01

#### 1. IMPACT SENSITIVITY S909330A0101

#### NOTE:

Before adjustment, make sure the security control module has been securely installed on the bracket.

- 1) Remove security control module. <Ref. to SL-50 REMOVAL, Security Control Module.>
- 2) Adjust the sensitivity adjust screw in security control module.

#### NOTE:

After adjusting, be sure to plug the adjust screw hole.

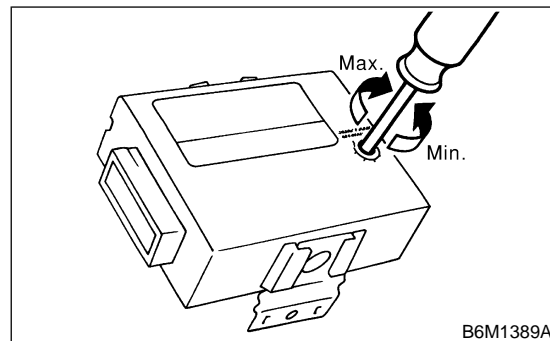

- 3) Install security control module.
- 4) Perform impact sensitivity test.