

14. Diagnostics Chart with Subaru Select Monitor S006583

A: COMMUNICATION FOR INITIALIZING IMPOSSIBLE S006583E34

DIAGNOSIS:

- Faulty harness connector

TROUBLE SYMPTOM:

- ABS warning light remains on.

DIAGNOSTICS CHART WITH SUBARU SELECT MONITOR

ABS (DIAGNOSTICS)

WIRING DIAGRAM:

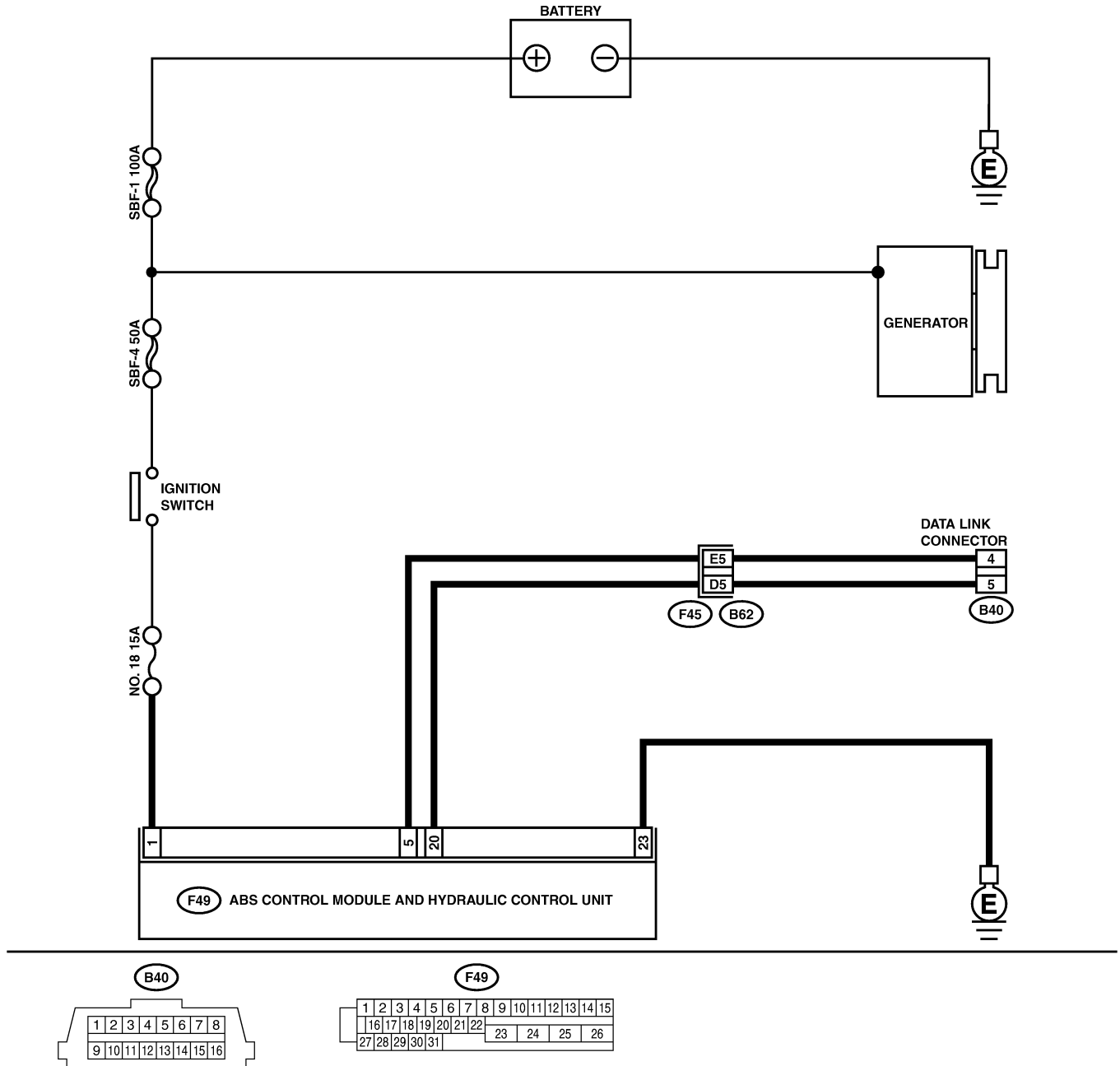

B4M1463

DIAGNOSTICS CHART WITH SUBARU SELECT MONITOR

ABS (DIAGNOSTICS)

No.	Step	Check	Yes	No
1	CHECK IGNITION SWITCH.	Is ignition switch ON?	Go to step 2.	Turn ignition switch ON, and select ABS/TCS mode using the select monitor.
2	CHECK GENERATOR. 1) Start the engine. 2) Idle the engine. 3) Measure voltage between generator and chassis ground. Terminal Generator B terminal (+) — Chassis ground (-):	Is the voltage between 10 and 15 V?	Go to step 3.	Repair generator. <Ref. to SC(H4)-15 Generator.>
3	CHECK BATTERY TERMINAL. Turn ignition switch to OFF.	Is there poor contact at battery terminal?	Repair battery terminal.	Go to step 4.
4	CHECK COMMUNICATION OF SELECT MONITOR. Using the select monitor, check whether communication to other system (such as engine, AT, etc.) can be executed normally.	Are the name and year of the system displayed on the select monitor?	Go to step 5.	Repair select monitor communication cable and connector.
5	CHECK INSTALLATION OF ABSCM&H/U CONNECTOR. Turn ignition switch to OFF.	Is ABSCM&H/U connector inserted into ABSCM&H/U until the clamp locks onto it?	Go to step 6.	Insert ABSCM&H/U connector into ABSCM&H/U until the clamp locks onto it.
6	CHECK POWER SUPPLY OF ABSCM&H/U. 1) Disconnect connector from ABSCM&H/U. 2) Start engine. 3) Idle the engine. 4) Measure voltage between ABSCM&H/U connector and chassis ground. Connector & terminal (F49) No. 1 (+) — Chassis ground (-):	Is the voltage between 10 and 15 V?	Go to step 7.	Repair ABSCM&H/U power supply circuit.
7	CHECK GROUND CIRCUIT OF ABSCM&H/U. 1) Turn ignition switch to OFF. 2) Measure resistance between ABSCM&H/U connector and chassis ground. Connector & terminal (F49) No. 23 — Chassis ground:	Is the resistance less than 0.5 Ω?	Repair harness/connector between ABSCM&H/U and select monitor.	Go to step 8.
8	CHECK HARNESS/CONNECTOR BETWEEN ABSCM&H/U AND DATA LINK CONNECTOR. 1) Turn ignition switch OFF. 2) Measure resistance between ABSCM&H/U connector and data link connector. Connector & terminal (F49) No. 20 — (B40) No. 5: (F49) No. 5 — (B40) No. 4:	Is the resistance less than 0.5 Ω?	Repair harness and connector between ABSCM&H/U and data link connector.	Go to step 9.
9	CHECK POOR CONTACT IN CONNECTORS.	Is there poor contact in connectors between ABSCM&H/U and data link connector?	Repair connector.	Replace ABSCM&H/U. <Ref. to ABS-7 ABS Control Module and Hydraulic Control Unit (ABSCM&H/U).>

DIAGNOSTICS CHART WITH SUBARU SELECT MONITOR

ABS (DIAGNOSTICS)

MEMO:

ABS-91

DIAGNOSTICS CHART WITH SUBARU SELECT MONITOR

ABS (DIAGNOSTICS)

B: NO TROUBLE CODE S006583E41

DIAGNOSIS:

- ABS warning light circuit is shorted.

TROUBLE SYMPTOM:

- ABS warning light remains on.
- NO TROUBLE CODE displayed on the select monitor.

NOTE:

When the ABS warning light is OFF and "NO TROUBLE CODE" is displayed on the select monitor, the system is in normal condition.

DIAGNOSTICS CHART WITH SUBARU SELECT MONITOR

ABS (DIAGNOSTICS)

WIRING DIAGRAM:

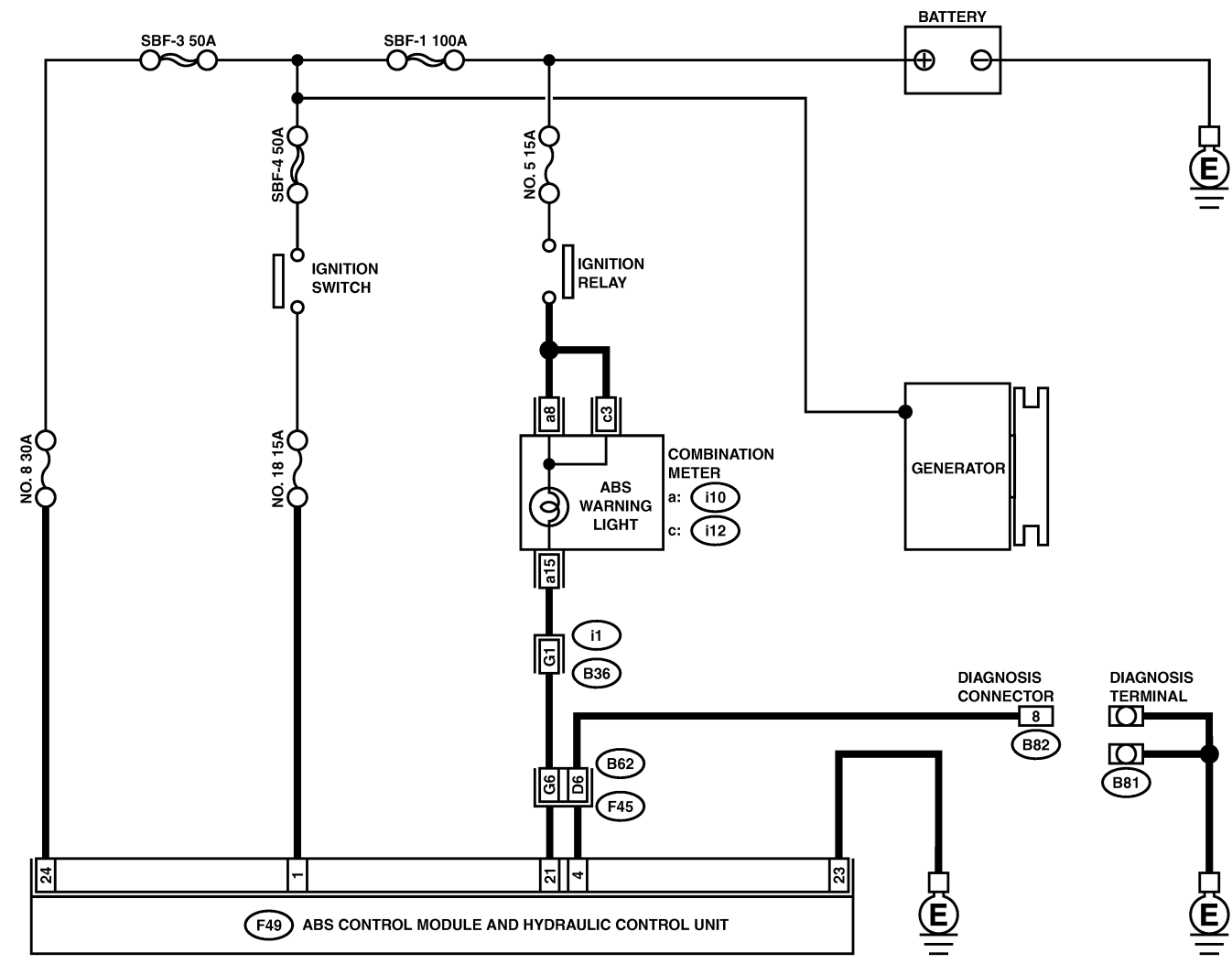

(B82)

1	2	3
4	5	6
7	8	

(i12)

1	2	3	4	5	6
7	8	9	10	11	12
13	14				

(F49)

1	2	3	4	5	6	7	8	9	10	11	12	13	14	15
16	17	18	19	20	21	22	23	24	25	26				
27	28	29	30	31										

(i10)

1	2	3	4	5	6	7	8	9	10	11	12	13	14
15	16	17	18	19	20	21	22	23	24	25	26	27	28
29	30												

(B36) (B62)

A1	A2	A3	A4	A5	A6
B1	B2	B3	B4	B5	B6
C1	C2	C3	C4	C5	C6
D1	D2	D3	D4	D5	D6
E1	E2	E3	E4	E5	E6
F1	F2	F3	F4	F5	F6
G1	G2	G3	G4	G5	G6
H1	H2	H3	H4	H5	H6
I1	I2	I3	I4	I5	I6
J1	J2	J3	J4	J5	J6
K1	K2	K3	K4	K5	K6
L1	L2	L3	L4	L5	L6
M1	M2	M3	M4	M5	M6
N1	N2	N3	N4	N5	N6
O1	O2	O3	O4	O5	O6
P1	P2	P3	P4	P5	P6

B4M1454

DIAGNOSTICS CHART WITH SUBARU SELECT MONITOR

ABS (DIAGNOSTICS)

No.	Step	Check	Yes	No
1	CHECK WIRING HARNESS. 1) Turn ignition switch to OFF. 2) Disconnect connector (F45) from connector (B62). 3) Turn ignition switch to ON.	Does the ABS warning light remain off?	Go to step 2.	Repair front wiring harness.
2	CHECK PROJECTION AT ABSCM&H/U. 1) Turn ignition switch to OFF. 2) Disconnect connector from ABSCM&H/U. 3) Check for broken projection at the ABSCM&H/U terminal.	Are the projection broken?	Go to step 3.	Replace ABSCM&H/U. <Ref. to ABS-7 ABS Control Module and Hydraulic Control Unit (ABSCM&H/U).>
3	CHECK ABSCM&H/U. Measure resistance between ABSCM&H/U terminals. <i>Terminals</i> <i>No. 21 — No. 23:</i>	Is the resistance more than 1 M Ω ?	Go to step 4.	Replace ABSCM&H/U. <Ref. to ABS-7 ABS Control Module and Hydraulic Control Unit (ABSCM&H/U).>
4	CHECK WIRING HARNESS. Measure resistance between connector (F45) and chassis ground. <i>Connector & terminal</i> <i>(F45) No. G6 — Chassis ground:</i>	Is the resistance less than 0.5 Ω ?	Go to step 5.	Repair harness.
5	CHECK WIRING HARNESS. 1) Connect connector to ABSCM&H/U. 2) Measure resistance between connector (F45) and chassis ground. <i>Connector & terminal</i> <i>(F45) No. G6 — Chassis ground:</i>	Is the resistance more than 1 M Ω ?	Go to step 6.	Repair harness.
6	CHECK POOR CONTACT IN ABSCM&H/U CONNECTOR.	Is there poor contact in ABSCM&H/U connector?	Repair connector.	Replace ABSCM&H/U. <Ref. to ABS-7 ABS Control Module and Hydraulic Control Unit (ABSCM&H/U).>

DIAGNOSTICS CHART WITH SUBARU SELECT MONITOR

ABS (DIAGNOSTICS)

MEMO:

ABS-95

DIAGNOSTICS CHART WITH SUBARU SELECT MONITOR

ABS (DIAGNOSTICS)

C: TROUBLE CODE 21

— OPEN OR SHORT CIRCUIT IN FRONT RIGHT ABS SENSOR CIRCUIT — S006583C50

NOTE:

For the diagnostic procedure, refer to TROUBLE CODE 27. <Ref. to ABS-96 TROUBLE CODE 27 — OPEN OR SHORT CIRCUIT IN REAR LEFT ABS SENSOR CIRCUIT —, Diagnostics Chart with Subaru Select Monitor.>

D: TROUBLE CODE 23

— OPEN OR SHORT CIRCUIT IN FRONT LEFT ABS SENSOR CIRCUIT — S006583C60

NOTE:

For the diagnostic procedure, refer to TROUBLE CODE 27. <Ref. to ABS-96 TROUBLE CODE 27 — OPEN OR SHORT CIRCUIT IN REAR LEFT ABS SENSOR CIRCUIT —, Diagnostics Chart with Subaru Select Monitor.>

E: TROUBLE CODE 25

— OPEN OR SHORT CIRCUIT IN REAR RIGHT ABS SENSOR CIRCUIT — S006583C69

NOTE:

For the diagnostic procedure, refer to TROUBLE CODE 27. <Ref. to ABS-96 TROUBLE CODE 27 — OPEN OR SHORT CIRCUIT IN REAR LEFT ABS SENSOR CIRCUIT —, Diagnostics Chart with Subaru Select Monitor.>

F: TROUBLE CODE 27

— OPEN OR SHORT CIRCUIT IN REAR LEFT ABS SENSOR CIRCUIT — S006583C78

DIAGNOSIS:

- Faulty ABS sensor (Broken wire, input voltage too high)
- Faulty harness connector

TROUBLE SYMPTOM:

- ABS does not operate.

DIAGNOSTICS CHART WITH SUBARU SELECT MONITOR

ABS (DIAGNOSTICS)

WIRING DIAGRAM:

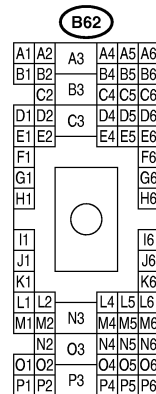
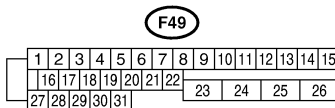
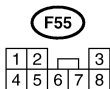
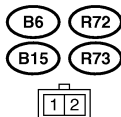
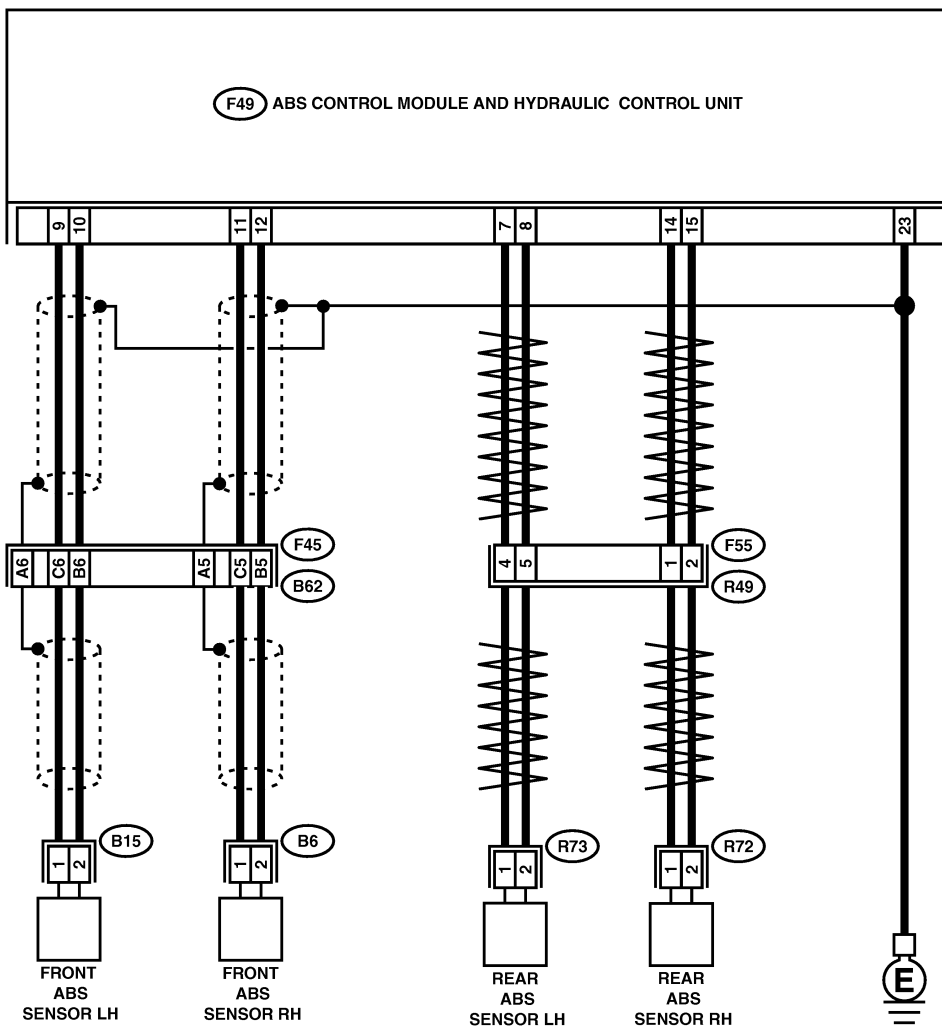

B4M1455

DIAGNOSTICS CHART WITH SUBARU SELECT MONITOR

ABS (DIAGNOSTICS)

No.	Step	Check	Yes	No
1	CHECK OUTPUT OF ABS SENSOR USING SELECT MONITOR. 1) Select "Current data display & Save" on the select monitor. 2) Read the ABS sensor output corresponding to the faulty system in the select monitor data display mode.	Does the speed indicated on the display change in response to the speedometer reading during acceleration/deceleration when the steering wheel is in the straight-ahead position?	Go to step 2.	Go to step 8.
2	CHECK INSTALLATION OF ABS SENSOR. Tightening torque: 32±10 N·m (3.3±1.0 kgf·m, 24±7 ft·lb)	Are the ABS sensor installation bolts tightened securely?	Go to step 3.	Tighten ABS sensor installation bolts securely.
3	CHECK ABS SENSOR GAP. Measure tone wheel to ABS sensor piece gap over entire perimeter of the wheel. Front wheel 0.3 — 0.8 mm (0.012 — 0.031 in) Rear wheel 0.44 — 0.94 mm (0.0173 — 0.0370 in)	Is the gap within the specifications?	Go to step 4.	Adjust the gap. NOTE: Adjust the gap using spacers (Part No. 26755AA000). If spacers cannot correct the gap, replace worn sensor or worn tone wheel.
4	CHECK TONE WHEEL RUNOUT. Measure tone wheel runout.	Is the runout less than 0.05 mm (0.0020 in)?	Go to step 5.	Replace tone wheel. Front: <Ref. to ABS-22 Front Tone Wheel.> Rear: <Ref. to ABS-23 Rear Tone Wheel.>
5	CHECK POOR CONTACT IN CONNECTORS. Turn ignition switch to OFF.	Is there poor contact in connectors between ABSCM&H/U and ABS sensor?	Repair connector.	Go to step 6.
6	CHECK ABSCM&H/U. 1) Connect all connectors. 2) Erase the memory. 3) Perform inspection mode. 4) Read out the trouble code.	Is the same trouble code as in the current diagnosis still being output?	Replace ABSCM&H/U. <Ref. to ABS-7 ABS Control Module and Hydraulic Control Unit (ABSCM&H/U).>	Go to step 7.
7	CHECK ANY OTHER TROUBLE CODES APPEARANCE.	Are other trouble codes being output?	Proceed with the diagnosis corresponding to the trouble code.	A temporary poor contact. NOTE: Check harness and connectors between ABSCM&H/U and ABS sensor.
8	CHECK ABS SENSOR. 1) Turn ignition switch to OFF. 2) Disconnect connector from ABS sensor. 3) Measure resistance of ABS sensor connector terminals. Terminal Front RH No. 1 — No. 2: Front LH No. 1 — No. 2: Rear RH No. 1 — No. 2: Rear LH No. 1 — No. 2:	Is the resistance between 1 and 1.5 kΩ?	Go to step 9.	Replace ABS sensor. Front: <Ref. to ABS-14 Front ABS Sensor.> Rear: <Ref. to ABS-17 Rear ABS Sensor.>

DIAGNOSTICS CHART WITH SUBARU SELECT MONITOR

ABS (DIAGNOSTICS)

No.	Step	Check	Yes	No
9	<p>CHECK BATTERY SHORT OF ABS SENSOR. 1) Disconnect connector from ABSCM&H/U. 2) Measure voltage between ABS sensor and chassis ground.</p> <p>Terminal <i>Front RH No. 1 (+) — Chassis ground (-):</i> <i>Front LH No. 1 (+) — Chassis ground (-):</i> <i>Rear RH No. 1 (+) — Chassis ground (-):</i> <i>Rear LH No. 1 (+) — Chassis ground (-):</i></p>	Is the voltage less than 1 V?	Go to step 10.	Replace ABS sensor. Front: <Ref. to ABS-14 Front ABS Sensor.> Rear: <Ref. to ABS-17 Rear ABS Sensor.>
10	<p>CHECK BATTERY SHORT OF ABS SENSOR. 1) Turn ignition switch to ON. 2) Measure voltage between ABS sensor and chassis ground.</p> <p>Terminal <i>Front RH No. 1 (+) — Chassis ground (-):</i> <i>Front LH No. 1 (+) — Chassis ground (-):</i> <i>Rear RH No. 1 (+) — Chassis ground (-):</i> <i>Rear LH No. 1 (+) — Chassis ground (-):</i></p>	Is the voltage less than 1 V?	Go to step 11.	Replace ABS sensor. Front: <Ref. to ABS-14 Front ABS Sensor.> Rear: <Ref. to ABS-17 Rear ABS Sensor.>
11	<p>CHECK HARNESS/CONNECTOR BETWEEN ABSCM&H/U AND ABS SENSOR. 1) Turn ignition switch to OFF. 2) Connect connector to ABS sensor. 3) Measure resistance between ABSCM&H/U connector terminals.</p> <p>Connector & terminal <i>Trouble code 21 / (F49) No. 11 — No. 12:</i> <i>Trouble code 23 / (F49) No. 9 — No. 10:</i> <i>Trouble code 25 / (F49) No. 14 — No. 15:</i> <i>Trouble code 27 / (F49) No. 7 — No. 8:</i></p>	Is the resistance between 1 and 1.5 kΩ?	Go to step 12.	Repair harness/connector between ABSCM&H/U and ABS sensor.
12	<p>CHECK BATTERY SHORT OF HARNESS. Measure voltage between ABSCM&H/U connector and chassis ground.</p> <p>Connector & terminal <i>Trouble code 21 / (F49) No. 11 (+) — Chassis ground (-):</i> <i>Trouble code 23 / (F49) No. 9 (+) — Chassis ground (-):</i> <i>Trouble code 25 / (F49) No. 14 (+) — Chassis ground (-):</i> <i>Trouble code 27 / (F49) No. 7 (+) — Chassis ground (-):</i></p>	Is the voltage less than 1 V?	Go to step 13.	Repair harness between ABSCM&H/U and ABS sensor.

DIAGNOSTICS CHART WITH SUBARU SELECT MONITOR

ABS (DIAGNOSTICS)

No.	Step	Check	Yes	No
13	<p>CHECK BATTERY SHORT OF HARNESS. 1) Turn ignition switch to ON. 2) Measure voltage between ABSCM&H/U connector and chassis ground.</p> <p>Connector & terminal <i>Trouble code 21 / (F49) No. 11 (+) — Chassis ground (-):</i> <i>Trouble code 23 / (F49) No. 9 (+) — Chassis ground (-):</i> <i>Trouble code 25 / (F49) No. 14 (+) — Chassis ground (-):</i> <i>Trouble code 27 / (F49) No. 7 (+) — Chassis ground (-):</i></p>	Is the voltage less than 1 V?	Go to step 14.	Repair harness between ABSCM&H/U and ABS sensor.
14	<p>CHECK INSTALLATION OF ABS SENSOR. Tightening torque: 32±10 N·m (3.3±1.0 kgf-m, 24±7 ft-lb)</p>	Are the ABS sensor installation bolts tightened securely?	Go to step 15.	Tighten ABS sensor installation bolts securely.
15	<p>CHECK ABS SENSOR GAP. Measure tone wheel to ABS sensor piece gap over entire perimeter of the wheel.</p> <p>Front wheel 0.3 — 0.8 mm (0.012 — 0.031 in)</p> <p>Rear wheel 0.44 — 0.94 mm (0.0173 — 0.0370 in)</p>	Is the gap within the specifications?	Go to step 16.	Adjust the gap. NOTE: Adjust the gap using spacers (Part No. 26755AA000). If spacers cannot correct the gap, replace worn sensor or worn tone wheel.
16	<p>CHECK TONE WHEEL RUNOUT. Measure tone wheel runout.</p>	Is the runout less than 0.05 mm (0.0020 in)?	Go to step 17.	Replace tone wheel. Front: <Ref. to ABS-22 Front Tone Wheel.> Rear: <Ref. to ABS-23 Rear Tone Wheel.>
17	<p>CHECK GROUND SHORT OF ABS SENSOR. 1) Turn ignition switch to ON. 2) Measure resistance between ABS sensor and chassis ground.</p> <p>Terminal <i>Front RH No. 1 — Chassis ground:</i> <i>Front LH No. 1 — Chassis ground:</i> <i>Rear RH No. 1 — Chassis ground:</i> <i>Rear LH No. 1 — Chassis ground:</i></p>	Is the resistance more than 1 MΩ?	Go to step 18.	Replace ABS sensor and ABSCM&H/U. Front: <Ref. to ABS-14 Front ABS Sensor.> Rear: <Ref. to ABS-17 Rear ABS Sensor.> and <Ref. to ABS-7 ABS Control Module and Hydraulic Control Unit (ABSCM&H/U).>

DIAGNOSTICS CHART WITH SUBARU SELECT MONITOR

ABS (DIAGNOSTICS)

No.	Step	Check	Yes	No
18	CHECK GROUND SHORT OF HARNESS. 1) Turn ignition switch to OFF. 2) Connect connector to ABS sensor. 3) Measure resistance between ABSCM&H/U connector terminal and chassis ground. Connector & terminal <i>Trouble code 21 / (F49) No. 11 — Chassis ground:</i> <i>Trouble code 23 / (F49) No. 9 — Chassis ground:</i> <i>Trouble code 25 / (F49) No. 14 — Chassis ground:</i> <i>Trouble code 27 / (F49) No. 7 — Chassis ground:</i>	Is the resistance more than 1 MΩ?	Go to step 19.	Repair harness between ABSCM&H/U and ABS sensor. And replace ABSCM&H/U. <Ref. to ABS-7 ABS Control Module and Hydraulic Control Unit (ABSCM&H/U).>
19	CHECK POOR CONTACT IN CONNECTORS.	Is there poor contact in connectors between ABSCM&H/U and ABS sensor?	Repair connector.	Go to step 20.
20	CHECK ABSCM&H/U. 1) Connect all connectors. 2) Erase the memory. 3) Perform inspection mode. 4) Read out the trouble code.	Is the same trouble code as in the current diagnosis still being output?	Replace ABSCM&H/U.	Go to step 21.
21	CHECK ANY OTHER TROUBLE CODES APPEARANCE.	Are other trouble codes being output?	Proceed with the diagnosis corresponding to the trouble code.	A temporary poor contact. NOTE: Check harness and connectors between ABSCM&H/U and ABS sensor.

DIAGNOSTICS CHART WITH SUBARU SELECT MONITOR

ABS (DIAGNOSTICS)

G: TROUBLE CODE 22

— FRONT RIGHT ABNORMAL ABS SENSOR SIGNAL — S006583C54

NOTE:

For the diagnostic procedure, refer to TROUBLE CODE 28. <Ref. to ABS-102 TROUBLE CODE 28 — REAR LEFT ABNORMAL ABS SENSOR SIGNAL —, Diagnostics Chart with Subaru Select Monitor.>

H: TROUBLE CODE 24

— FRONT LEFT ABNORMAL ABS SENSOR SIGNAL — S006583C64

NOTE:

For the diagnostic procedure, refer to TROUBLE CODE 28. <Ref. to ABS-102 TROUBLE CODE 28 — REAR LEFT ABNORMAL ABS SENSOR SIGNAL —, Diagnostics Chart with Subaru Select Monitor.>

I: TROUBLE CODE 26

— REAR RIGHT ABNORMAL ABS SENSOR SIGNAL — S006583C73

NOTE:

For the diagnostic procedure, refer to TROUBLE CODE 28. <Ref. to ABS-102 TROUBLE CODE 28 — REAR LEFT ABNORMAL ABS SENSOR SIGNAL —, Diagnostics Chart with Subaru Select Monitor.>

J: TROUBLE CODE 28

— REAR LEFT ABNORMAL ABS SENSOR SIGNAL — S006583C82

DIAGNOSIS:

- Faulty ABS sensor signal (noise, irregular signal, etc.)
- Faulty harness/connector

TROUBLE SYMPTOM:

- ABS does not operate.

DIAGNOSTICS CHART WITH SUBARU SELECT MONITOR

ABS (DIAGNOSTICS)

WIRING DIAGRAM:

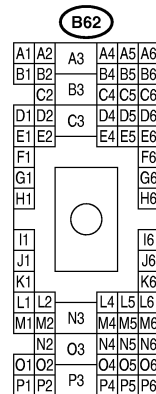
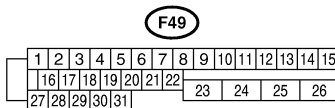
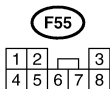
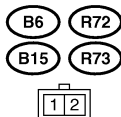
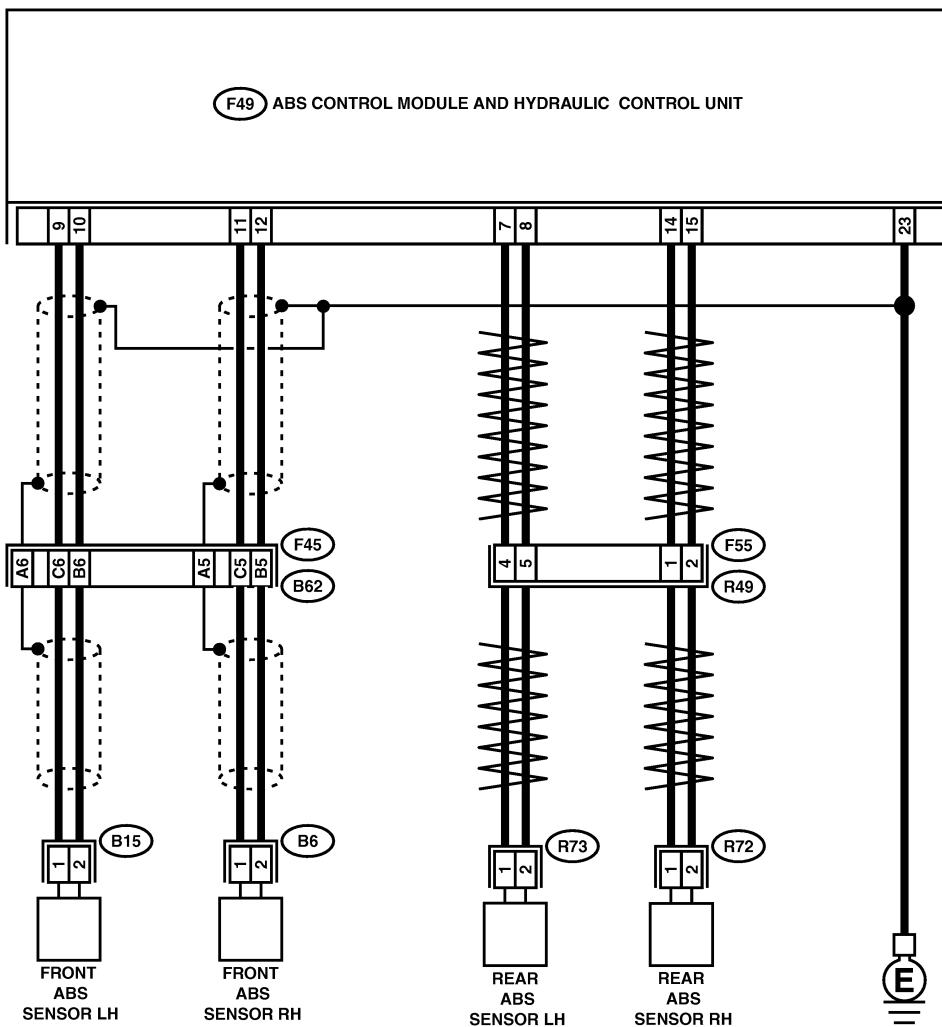

B4M1455

DIAGNOSTICS CHART WITH SUBARU SELECT MONITOR

ABS (DIAGNOSTICS)

No.	Step	Check	Yes	No
1	CHECK OUTPUT OF ABS SENSOR USING SELECT MONITOR. 1) Select "Current data display & Save" on the select monitor. 2) Read the ABS sensor output corresponding to the faulty system in the select monitor data display mode.	Does the speed indicated on the display change in response to the speedometer reading during acceleration/deceleration when the steering wheel is in the straight-ahead position?	Go to step 2.	Go to step 8.
2	CHECK POOR CONTACT IN CONNECTORS. Turn ignition switch to OFF.	Is there poor contact in connectors between ABSCM&H/U and ABS sensor?	Repair connector.	Go to step 3.
3	CHECK SOURCES OF SIGNAL NOISE.	Is the car telephone or the wireless transmitter properly installed?	Go to step 4.	Properly install the car telephone or the wireless transmitter.
4	CHECK SOURCES OF SIGNAL NOISE.	Are noise sources (such as an antenna) installed near the sensor harness?	Install the noise sources apart from the sensor harness.	Go to step 5.
5	CHECK SHIELD CIRCUIT. 1) Turn ignition switch to OFF. 2) Connect all connectors. 3) Measure resistance between shield connector and chassis ground. Connector & terminal Trouble code 22 / (B62) No. A5 — Chassis ground: Trouble code 24 / (B62) No. A6 — Chassis ground: NOTE: For the Trouble code 26 and 28 : Go to step 6.	Is the resistance less than 0.5 Ω?	Go to step 6.	Repair shield harness.
6	CHECK ABSCM&H/U. 1) Connect all connectors. 2) Erase the memory. 3) Perform inspection mode. 4) Read out the trouble code.	Is the same trouble code as in the current diagnosis still being output?	Replace ABSCM&H/U. <Ref. to ABS-7 ABS Control Module and Hydraulic Control Unit (ABSCM&H/U).>	Go to step 7.
7	CHECK ANY OTHER TROUBLE CODES APPEARANCE.	Are other trouble codes being output?	Proceed with the diagnosis corresponding to the trouble code.	A temporary noise interference.
8	CHECK INSTALLATION OF ABS SENSOR. Tightening torque: 32±10 N·m (3.3±1.0 kgf-m, 24±7 ft-lb)	Are the ABS sensor installation bolts tightened securely?	Go to step 9.	Tighten ABS sensor installation bolts securely.
9	CHECK ABS SENSOR GAP. Measure tone wheel to ABS sensor piece gap over entire perimeter of the wheel. Front wheel 0.3 — 0.8 mm (0.012 — 0.031 in) Rear wheel 0.44 — 0.94 mm (0.0173 — 0.0370 in)	Is the gap within the specifications?	Go to step 10.	Adjust the gap. NOTE: Adjust the gap using spacer (Part No. 26755AA000). If spacers cannot correct the gap, replace worn sensor or worn tone wheel.
10	PREPARE OSCILLOSCOPE.	Is an oscilloscope available?	Go to step 11.	Go to step 12.

DIAGNOSTICS CHART WITH SUBARU SELECT MONITOR

ABS (DIAGNOSTICS)

No.	Step	Check	Yes	No
11	<p>CHECK ABS SENSOR SIGNAL. 1) Raise all four wheels of ground. 2) Turn ignition switch OFF. 3) Connect the oscilloscope to the connector. 4) Turn ignition switch ON. 5) Rotate wheels and measure voltage at specified frequency. NOTE: When this inspection is completed, the ABSCM&H/U sometimes stores the trouble code 29.</p> <p>Connector & terminal <i>Trouble code 22 / (B62) No. C5 (+) — No. B5 (-):</i> <i>Trouble code 24 / (B62) No. C6 (+) — No. B6 (-):</i> <i>Trouble code 26 / (F55) No. 1 (+) — No. 2 (-):</i> <i>Trouble code 28 / (F55) No. 4 (+) — No. 5 (-):</i></p>	Is oscilloscope pattern smooth, as shown in figure?	Go to step 15.	Go to step 12.
12	<p>CHECK CONTAMINATION OF ABS SENSOR OR TONE WHEEL. Remove disc rotor or drum from hub in accordance with trouble code.</p>	Is the ABS sensor piece or the tone wheel contaminated by dirt or other foreign matter?	Thoroughly remove dirt or other foreign matter.	Go to step 13.
13	<p>CHECK DAMAGE OF ABS SENSOR OR TONE WHEEL.</p>	Are there broken or damaged in the ABS sensor piece or the tone wheel?	Replace ABS sensor or tone wheel. Front: <Ref. to ABS-14 Front ABS Sensor.> Rear: <Ref. to ABS-17 Rear ABS Sensor.> and Front: <Ref. to ABS-22 Front Tone Wheel.> Rear: <Ref. to ABS-23 Rear Tone Wheel.>	Go to step 14.
14	<p>CHECK TONE WHEEL RUNOUT. Measure tone wheel runout.</p>	Is the runout less than 0.05 mm (0.0020 in)?	Go to step 15.	Replace tone wheel. Front: <Ref. to ABS-22 Front Tone Wheel.> Rear: <Ref. to ABS-23 Rear Tone Wheel.>
15	<p>CHECK RESISTANCE OF ABS SENSOR. 1) Turn ignition switch OFF. 2) Disconnect connector from ABS sensor. 3) Measure resistance between ABS sensor connector terminals.</p> <p>Terminal <i>Front RH No. 1 — No. 2:</i> <i>Front LH No. 1 — No. 2:</i> <i>Rear RH No. 1 — No. 2:</i> <i>Rear LH No. 1 — No. 2:</i></p>	Is the resistance between 1 and 1.5 kΩ?	Go to step 16.	Replace ABS sensor. Front: <Ref. to ABS-14 Front ABS Sensor.> Rear: <Ref. to ABS-17 Rear ABS Sensor.>

DIAGNOSTICS CHART WITH SUBARU SELECT MONITOR

ABS (DIAGNOSTICS)

No.	Step	Check	Yes	No
16	<p>CHECK GROUND SHORT OF ABS SENSOR. Measure resistance between ABS sensor and chassis ground.</p> <p>Terminal Front RH No. 1 — Chassis ground: Front LH No. 1 — Chassis ground: Rear RH No. 1 — Chassis ground: Rear LH No. 1 — Chassis ground:</p>	Is the resistance more than 1 M Ω ?	Go to step 17.	Replace ABS sensor. Front: <Ref. to ABS-14 Front ABS Sensor.> Rear: <Ref. to ABS-17 Rear ABS Sensor.>
17	<p>CHECK HARNESS/CONNECTOR BETWEEN ABSCM&H/U AND ABS SENSOR. 1) Connect connector to ABS sensor. 2) Disconnect connector from ABSCM&H/U. 3) Measure resistance at ABSCM&H/U connector terminals.</p> <p>Connector & terminal Trouble code 22 / (F49) No. 11 — No. 12: Trouble code 24 / (F49) No. 9 — No. 10: Trouble code 26 / (F49) No. 14 — No. 15: Trouble code 28 / (F49) No. 7 — No. 8:</p>	Is the resistance between 1 and 1.5 k Ω ?	Go to step 18.	Repair harness/connector between ABSCM&H/U and ABS sensor.
18	<p>CHECK GROUND SHORT OF HARNESS. Measure resistance between ABSCM&H/U connector and chassis ground.</p> <p>Connector & terminal Trouble code 22 / (F49) No. 11 — Chassis ground: Trouble code 24 / (F49) No. 9 — Chassis ground: Trouble code 26 / (F49) No. 14 — Chassis ground: Trouble code 28 / (F49) No. 7 — Chassis ground:</p>	Is the resistance more than 1 M Ω ?	Go to step 19.	Repair harness/connector between ABSCM&H/U and ABS sensor.
19	<p>CHECK GROUND CIRCUIT OF ABSCM&H/U. Measure resistance between ABSCM&H/U and chassis ground.</p> <p>Connector & terminal (F49) No. 23 — GND:</p>	Is the resistance less than 0.5 Ω ?	Go to step 20.	Repair ABSCM&H/U ground harness.
20	<p>CHECK POOR CONTACT IN CONNECTORS.</p>	Is there poor contact in connectors between ABSCM&H/U and ABS sensor?	Repair connector.	Go to step 21.
21	<p>CHECK SOURCES OF SIGNAL NOISE.</p>	Is the car telephone or the wireless transmitter properly installed?	Go to step 22.	Properly install the car telephone or the wireless transmitter.
22	<p>CHECK SOURCES OF SIGNAL NOISE.</p>	Are noise sources (such as an antenna) installed near the sensor harness?	Install the noise sources apart from the sensor harness.	Go to step 23.

DIAGNOSTICS CHART WITH SUBARU SELECT MONITOR

ABS (DIAGNOSTICS)

No.	Step	Check	Yes	No
23	CHECK SHIELD CIRCUIT. 1) Connect all connectors. 2) Measure resistance between shield connector and chassis ground. Connector & terminal <i>Trouble code 22 / (B62) No. A5 —</i> Chassis ground: <i>Trouble code 24 / (B62) No. A6 —</i> Chassis ground: NOTE: For the Trouble code 26 and 28 : Go to step 24.	Is the resistance less than 0.5 Ω?	Go to step 24.	Repair shield harness.
24	CHECK ABSCM&H/U. 1) Connect all connectors. 2) Erase the memory. 3) Perform inspection mode. 4) Read out the trouble code.	Is the same trouble code as in the current diagnosis still being output?	Replace ABSCM&H/U. <Ref. to ABS-7 ABS Control Module and Hydraulic Control Unit (ABSCM&H/U).>	Go to step 25.
25	CHECK ANY OTHER TROUBLE CODES APPEARANCE.	Are other trouble codes being output?	Proceed with the diagnosis corresponding to the trouble code.	A temporary noise interference.

DIAGNOSTICS CHART WITH SUBARU SELECT MONITOR

ABS (DIAGNOSTICS)

K: TROUBLE CODE 29

— ABNORMAL ABS SENSOR SIGNAL ON ANY ONE OF FOUR SENSOR — S006583E78

DIAGNOSIS:

- Faulty ABS sensor signal (noise, irregular signal, etc.)
- Faulty tone wheel
- Wheels turning freely for a long time

TROUBLE SYMPTOM:

- ABS does not operate.

DIAGNOSTICS CHART WITH SUBARU SELECT MONITOR

ABS (DIAGNOSTICS)

WIRING DIAGRAM:

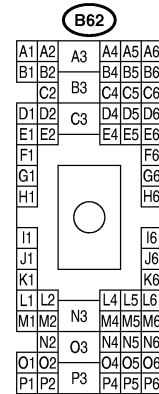
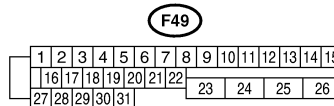
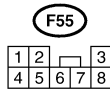
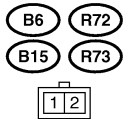
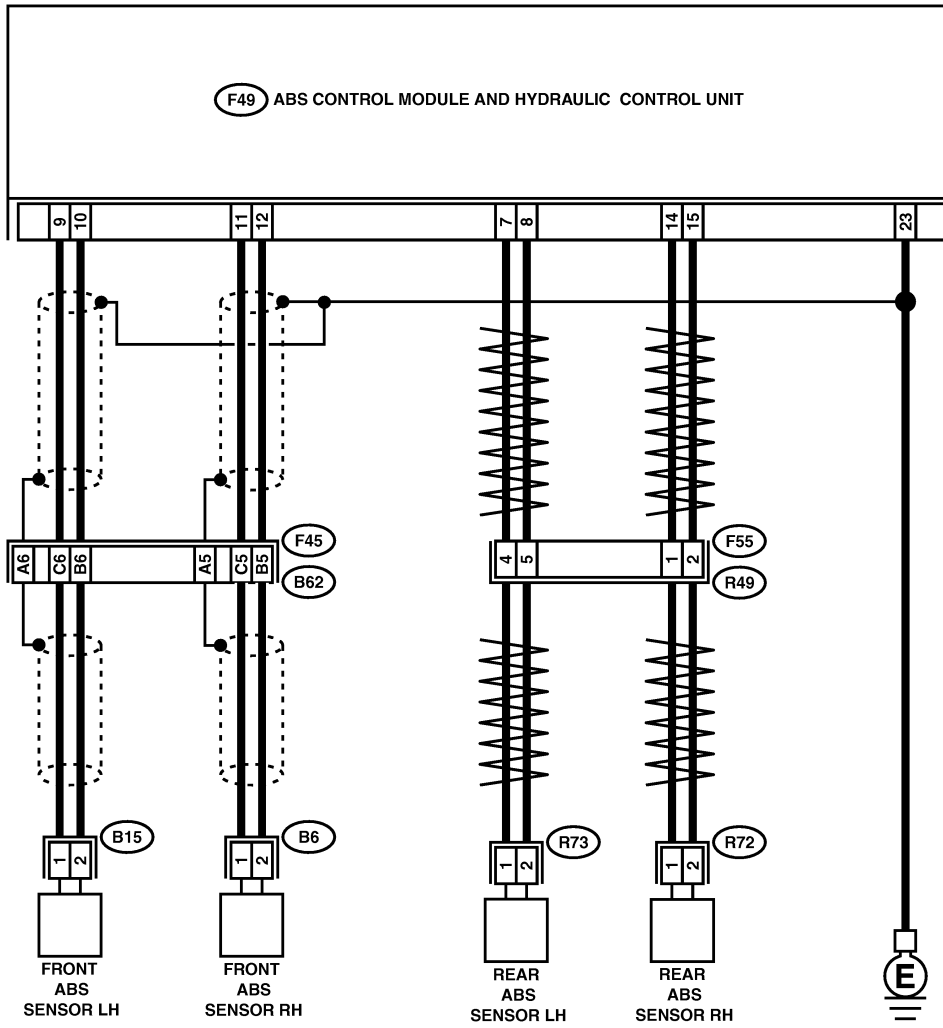

B4M1455

DIAGNOSTICS CHART WITH SUBARU SELECT MONITOR

ABS (DIAGNOSTICS)

No.	Step	Check	Yes	No
1	CHECK IF THE WHEELS HAVE TURNED FREELY FOR A LONG TIME.	Check if the wheels have been turned freely for more than one minute, such as when the vehicle is jacked-up, under full-lock cornering or when tire is not in contact with road surface.	The ABS is normal. Erase the trouble code. NOTE: When the wheels turn freely for a long time, such as when the vehicle is towed or jacked-up, or when steering wheel is continuously turned all the way, this trouble code may sometimes occur.	Go to step 2.
2	CHECK TIRE SPECIFICATIONS. Turn ignition switch to OFF.	Are the tire specifications correct?	Go to step 3.	Replace tire.
3	CHECK WEAR OF TIRE.	Is the tire worn excessively?	Replace tire.	Go to step 4.
4	CHECK TIRE PRESSURE.	Is the tire pressure correct?	Go to step 5.	Adjust tire pressure.
5	CHECK INSTALLATION OF ABS SENSOR. <i>Tightening torque:</i> 32±10 N·m (3.3±1.0 kgf·m, 24±7 ft·lb)	Are the ABS sensor installation bolts tightened securely?	Go to step 6.	Tighten ABS sensor installation bolts securely.
6	CHECK ABS SENSOR GAP. Measure tone wheel to ABS sensor piece gap over entire perimeter of the wheel. <i>Front wheel</i> 0.3 — 0.8 mm (0.012 — 0.031 in) <i>Rear wheel</i> 0.44 — 0.94 mm (0.0173 — 0.0370 in)	Is the gap within the specifications?	Go to step 7.	Adjust the gap. NOTE: Adjust the gap using spacer (Part No. 26755AA000). If spacers cannot correct the gap, replace worn sensor or worn tone wheel.
7	PREPARE OSCILLOSCOPE.	Is an oscilloscope available?	Go to step 8.	Go to step 9.
8	CHECK ABS SENSOR SIGNAL. 1) Raise all four wheels of ground. 2) Turn ignition switch OFF. 3) Connect the oscilloscope to the connector (B62) in accordance with trouble code. 4) Turn ignition switch ON. 5) Rotate wheels and measure voltage at specified frequency. NOTE: When this inspection is completed, the ABSCM&H/U sometimes stores the trouble code 29. Connector & terminal (B62) No. C5 (+) — No. B5 (-) (Front RH): (B62) No. C6 (+) — No. B6 (-) (Front LH): (F55) No. 1 (+) — No. 2 (-) (Rear RH): (F55) No. 4 (+) — No. 5 (-) (Rear LH):	Is oscilloscope pattern smooth, as shown in figure?	Go to step 12.	Go to step 9.

DIAGNOSTICS CHART WITH SUBARU SELECT MONITOR

ABS (DIAGNOSTICS)

No.	Step	Check	Yes	No
9	CHECK CONTAMINATION OF ABS SENSOR OR TONE WHEEL. Remove disc rotor from hub.	Is the ABS sensor piece or the tone wheel contaminated by dirt or other foreign matter?	Thoroughly remove dirt or other foreign matter.	Go to step 10.
10	CHECK DAMAGE OF ABS SENSOR OR TONE WHEEL.	Are there broken or damaged teeth in the ABS sensor piece or the tone wheel?	Replace ABS sensor or tone wheel. Front: <Ref. to ABS-14 Front ABS Sensor.> Rear: <Ref. to ABS-17 Rear ABS Sensor.> and Front: <Ref. to ABS-22 Front Tone Wheel.> Rear: <Ref. to ABS-23 Rear Tone Wheel.>	Go to step 11.
11	CHECK TONE WHEEL RUNOUT. Measure tone wheel runout.	Is the runout less than 0.05 mm (0.0020 in)?	Go to step 12.	Replace tone wheel. Front: <Ref. to ABS-22 Front Tone Wheel.> Rear: <Ref. to ABS-23 Rear Tone Wheel.>
12	CHECK ABSCM&H/U. 1) Turn ignition switch to OFF. 2) Connect all connectors. 3) Erase the memory. 4) Perform inspection mode. 5) Read out the trouble code.	Is the same trouble code as in the current diagnosis still being output?	Replace ABSCM&H/U. <Ref. to ABS-7 ABS Control Module and Hydraulic Control Unit (ABSCM&H/U).>	Go to step 13.
13	CHECK ANY OTHER TROUBLE CODES APPEARANCE.	Are other trouble codes being output?	Proceed with the diagnosis corresponding to the trouble code.	A temporary poor contact.

DIAGNOSTICS CHART WITH SUBARU SELECT MONITOR

ABS (DIAGNOSTICS)

L: TROUBLE CODE 31

— FRONT RIGHT INLET VALVE MALFUNCTION — S006583C93

NOTE:

For the diagnostic procedure, refer to TROUBLE CODE 37. <Ref. to ABS-112 TROUBLE CODE 37 — REAR LEFT INLET VALVE MALFUNCTION —, Diagnostics Chart with Subaru Select Monitor.>

M: TROUBLE CODE 33

— FRONT LEFT INLET VALVE MALFUNCTION — S006583D03

NOTE:

For the diagnostic procedure, refer to TROUBLE CODE 37. <Ref. to ABS-112 TROUBLE CODE 37 — REAR LEFT INLET VALVE MALFUNCTION —, Diagnostics Chart with Subaru Select Monitor.>

N: TROUBLE CODE 35

— REAR RIGHT INLET VALVE MALFUNCTION — S006583D11

NOTE:

For the diagnostic procedure, refer to TROUBLE CODE 37. <Ref. to ABS-112 TROUBLE CODE 37 — REAR LEFT INLET VALVE MALFUNCTION —, Diagnostics Chart with Subaru Select Monitor.>

O: TROUBLE CODE 37

— REAR LEFT INLET VALVE MALFUNCTION — S006583D20

DIAGNOSIS:

- Faulty harness/connector
- Faulty inlet solenoid valve

TROUBLE SYMPTOM:

- ABS does not operate.

DIAGNOSTICS CHART WITH SUBARU SELECT MONITOR

ABS (DIAGNOSTICS)

WIRING DIAGRAM:

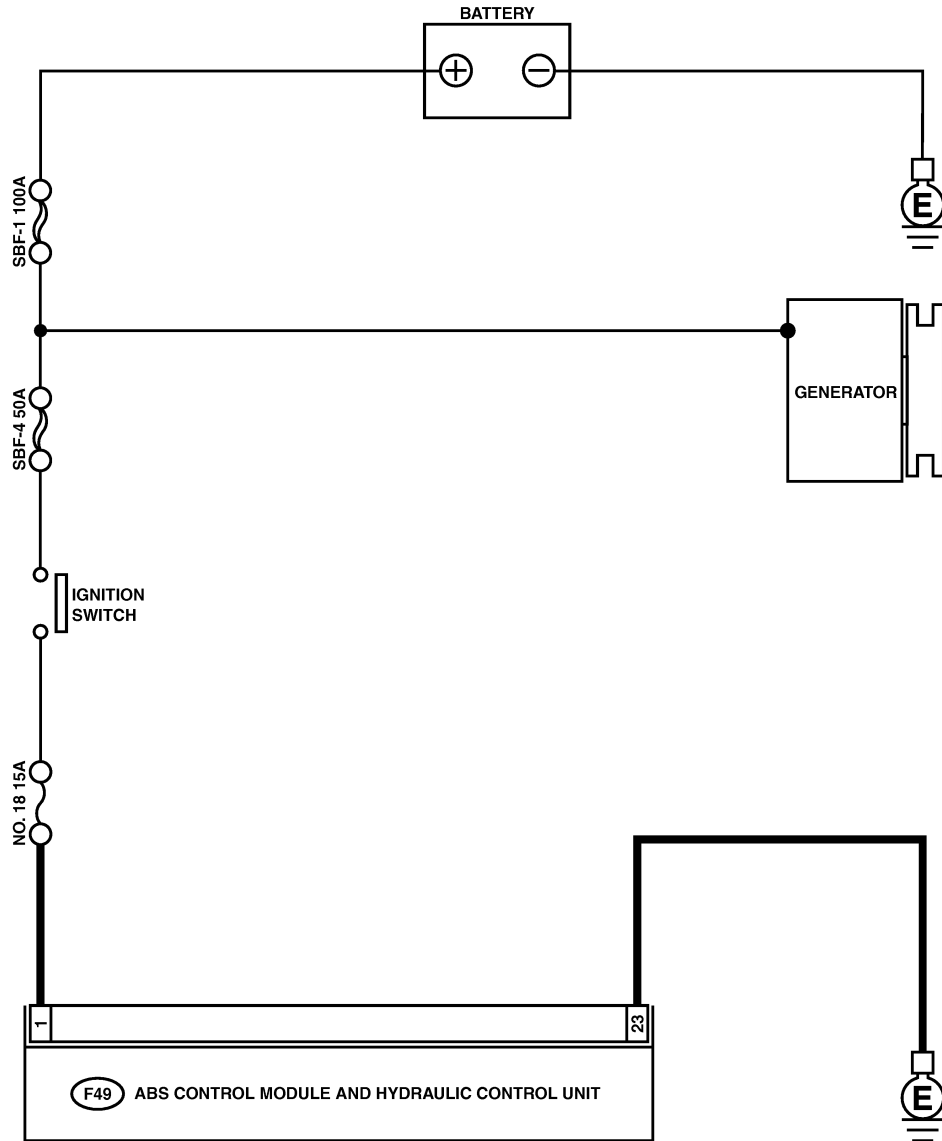

F49

1	2	3	4	5	6	7	8	9	10	11	12	13	14	15
16	17	18	19	20	21	22		23	24	25	26			
27	28	29	30	31										

B4M2334

DIAGNOSTICS CHART WITH SUBARU SELECT MONITOR

ABS (DIAGNOSTICS)

No.	Step	Check	Yes	No
1	CHECK INPUT VOLTAGE OF ABSCM&H/U. 1) Turn ignition switch to OFF. 2) Disconnect connector from ABSCM&H/U. 3) Run the engine at idle. 4) Measure voltage between ABSCM&H/U connector and chassis ground. Connector & terminal (F49) No. 1 (+) — Chassis ground (-):	Is the voltage between 10 and 15 V?	Go to step 2.	Repair harness connector between battery, ignition switch and ABSCM&H/U.
2	CHECK GROUND CIRCUIT OF ABSCM&H/U. 1) Turn ignition switch to OFF. 2) Measure resistance between ABSCM&H/U connector and chassis ground. Connector & terminal (F49) No. 23 — Chassis ground:	Is the resistance less than 0.5 Ω?	Go to step 3.	Repair ABSCM&H/U ground harness.
3	CHECK POOR CONTACT IN CONNECTORS.	Is there poor contact in connectors between generator, battery and ABSCM&H/U?	Repair connector.	Go to step 4.
4	CHECK ABSCM&H/U. 1) Connect all connectors. 2) Erase the memory. 3) Perform inspection mode. 4) Read out the trouble code.	Is the same trouble code as in the current diagnosis still being output?	Replace ABSCM&H/U. <Ref. to ABS-7 ABS Control Module and Hydraulic Control Unit (ABSCM&H/U).>	Go to step 5.
5	CHECK ANY OTHER TROUBLE CODES APPEARANCE.	Are other trouble codes being output?	Proceed with the diagnosis corresponding to the trouble code.	A temporary poor contact.

DIAGNOSTICS CHART WITH SUBARU SELECT MONITOR

ABS (DIAGNOSTICS)

MEMO:

ABS-115

DIAGNOSTICS CHART WITH SUBARU SELECT MONITOR

ABS (DIAGNOSTICS)

P: TROUBLE CODE 32

— FRONT RIGHT OUTLET VALVE MALFUNCTION — S006583C99

NOTE:

For the diagnostic procedure, refer to TROUBLE CODE 38. <Ref. to ABS-116 TROUBLE CODE 38 — REAR LEFT OUTLET VALVE MALFUNCTION —, Diagnostics Chart with Subaru Select Monitor.>

Q: TROUBLE CODE 34

— FRONT LEFT OUTLET VALVE MALFUNCTION — S006583D08

NOTE:

For the diagnostic procedure, refer to TROUBLE CODE 38. <Ref. to ABS-116 TROUBLE CODE 38 — REAR LEFT OUTLET VALVE MALFUNCTION —, Diagnostics Chart with Subaru Select Monitor.>

R: TROUBLE CODE 36

— REAR RIGHT OUTLET VALVE MALFUNCTION — S006583D15

NOTE:

For the diagnostic procedure, refer to TROUBLE CODE 38. <Ref. to ABS-116 TROUBLE CODE 38 — REAR LEFT OUTLET VALVE MALFUNCTION —, Diagnostics Chart with Subaru Select Monitor.>

S: TROUBLE CODE 38

— REAR LEFT OUTLET VALVE MALFUNCTION — S006583D24

DIAGNOSIS:

- Faulty harness/connector
- Faulty outlet solenoid valve

TROUBLE SYMPTOM:

- ABS does not operate.

DIAGNOSTICS CHART WITH SUBARU SELECT MONITOR

ABS (DIAGNOSTICS)

WIRING DIAGRAM:

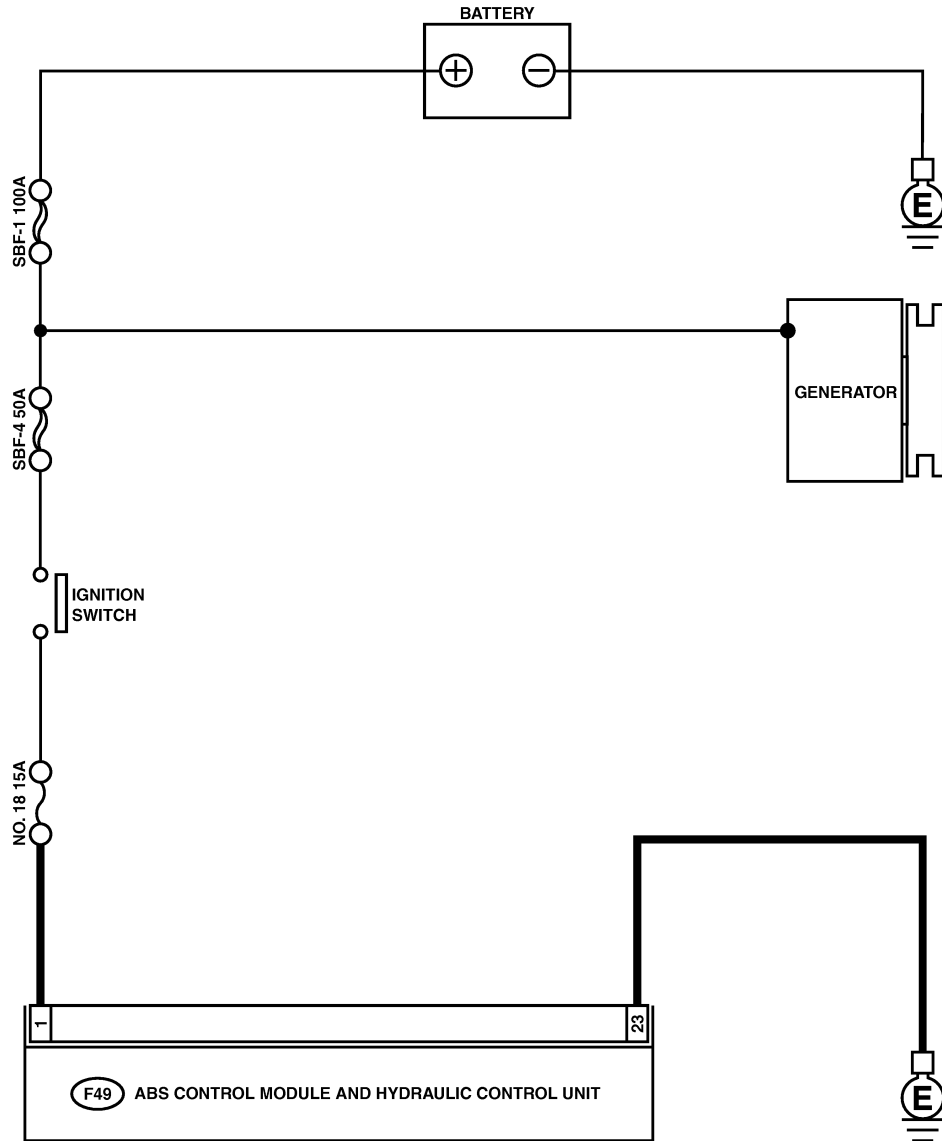

F49

1	2	3	4	5	6	7	8	9	10	11	12	13	14	15
16	17	18	19	20	21	22		23	24	25	26			
27	28	29	30	31										

B4M2334

DIAGNOSTICS CHART WITH SUBARU SELECT MONITOR

ABS (DIAGNOSTICS)

No.	Step	Check	Yes	No
1	CHECK INPUT VOLTAGE OF ABSCM&H/U. 1) Turn ignition switch to OFF. 2) Disconnect connector from ABSCM&H/U. 3) Run the engine at idle. 4) Measure voltage between ABSCM&H/U connector and chassis ground. Connector & terminal (F49) No. 1 (+) — Chassis ground (-):	Is the voltage between 10 and 15 V?	Go to step 2.	Repair harness connector between battery, ignition switch and ABSCM&H/U.
2	CHECK GROUND CIRCUIT OF ABSCM&H/U. 1) Turn ignition switch to OFF. 2) Measure resistance between ABSCM&H/U connector and chassis ground. Connector & terminal (F49) No. 23 — Chassis ground:	Is the resistance less than 0.5 Ω?	Go to step 3.	Repair ABSCM&H/U ground harness.
3	CHECK POOR CONTACT IN CONNECTORS.	Is there poor contact in connectors between generator, battery and ABSCM&H/U?	Repair connector.	Go to step 4.
4	CHECK ABSCM&H/U. 1) Connect all connectors. 2) Erase the memory. 3) Perform inspection mode. 4) Read out the trouble code.	Is the same trouble code as in the current diagnosis still being output?	Replace ABSCM&H/U. <Ref. to ABS-7 ABS Control Module and Hydraulic Control Unit (ABSCM&H/U).>	Go to step 5.
5	CHECK ANY OTHER TROUBLE CODES APPEARANCE.	Are other trouble codes being output?	Proceed with the diagnosis corresponding to the trouble code.	A temporary poor contact.

DIAGNOSTICS CHART WITH SUBARU SELECT MONITOR

ABS (DIAGNOSTICS)

MEMO:

ABS-119

DIAGNOSTICS CHART WITH SUBARU SELECT MONITOR

ABS (DIAGNOSTICS)

T: TROUBLE CODE 41 — ABS CONTROL MODULE MALFUNCTION —

S006583D31

DIAGNOSIS:

- Faulty ABSCM&H/U

TROUBLE SYMPTOM:

- ABS does not operate.

WIRING DIAGRAM:

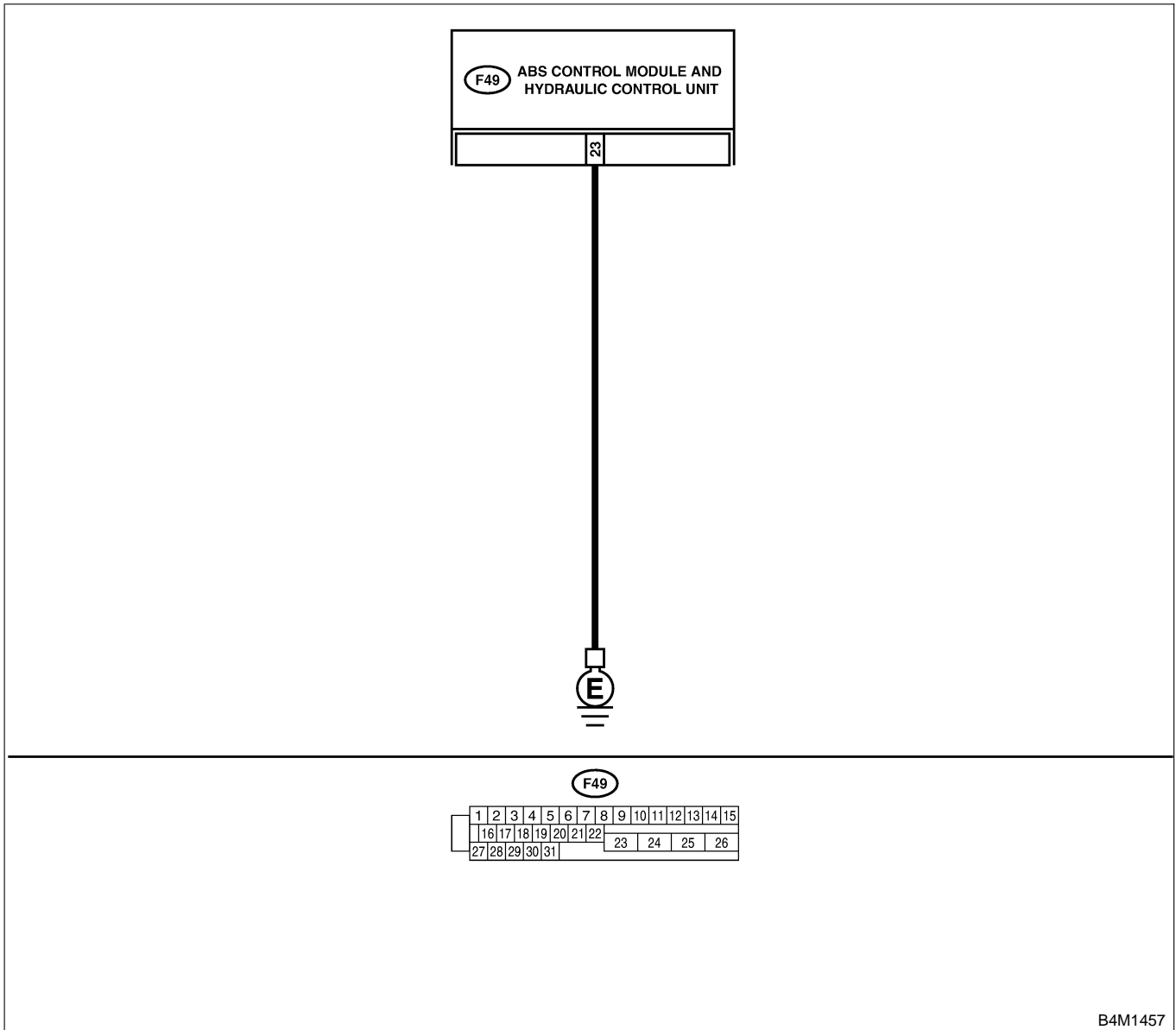

DIAGNOSTICS CHART WITH SUBARU SELECT MONITOR

ABS (DIAGNOSTICS)

No.	Step	Check	Yes	No
1	CHECK GROUND CIRCUIT OF ABSCM&H/U. 1) Turn ignition switch to OFF. 2) Disconnect connector from ABSCM&H/U. 3) Measure resistance between ABSCM&H/U and chassis ground. <i>Connector & terminal (F49) No. 23 — Chassis ground:</i>	Is the resistance less than 0.5 Ω ?	Go to step 2.	Repair ABSCM&H/U ground harness.
2	CHECK POOR CONTACT IN CONNECTORS.	Is there poor contact in connectors between battery, ignition switch and ABSCM&H/U?	Repair connector.	Go to step 3.
3	CHECK SOURCES OF SIGNAL NOISE.	Is the car telephone or the wireless transmitter properly installed?	Go to step 4.	Properly install the car telephone or the wireless transmitter.
4	CHECK SOURCES OF SIGNAL NOISE.	Are noise sources (such as an antenna) installed near the sensor harness?	Install the noise sources apart from the sensor harness.	Go to step 5.
5	CHECK ABSCM&H/U. 1) Turn ignition switch to OFF. 2) Connect all connectors. 3) Erase the memory. 4) Perform inspection mode. 5) Read out the trouble code.	Is the same trouble code as in the current diagnosis still being output?	Replace ABSCM&H/U. <Ref. to ABS-7 ABS Control Module and Hydraulic Control Unit (ABSCM&H/U).>	Go to step 6.
6	CHECK ANY OTHER TROUBLE CODES APPEARANCE.	Are other trouble codes being output?	Proceed with the diagnosis corresponding to the trouble code.	A temporary poor contact.

DIAGNOSTICS CHART WITH SUBARU SELECT MONITOR

ABS (DIAGNOSTICS)

U: TROUBLE CODE 42

— POWER SUPPLY VOLTAGE TOO LOW —

S006583D36

DIAGNOSIS:

- Power source voltage of the ABSCM&H/U is low.

TROUBLE SYMPTOM:

- ABS does not operate.

WIRING DIAGRAM:

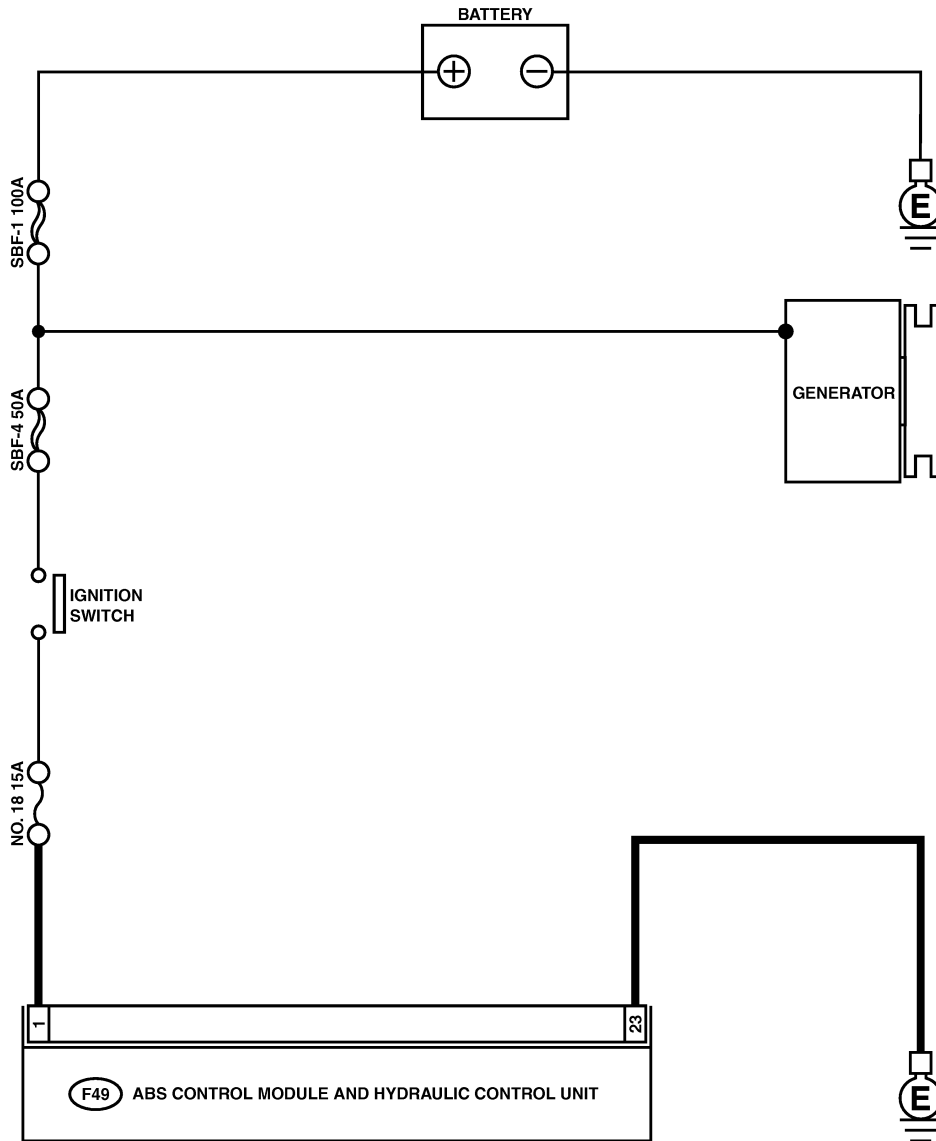

F49

1	2	3	4	5	6	7	8	9	10	11	12	13	14	15
16	17	18	19	20	21	22	23	24	25	26				
27	28	29	30	31										

B4M2334

DIAGNOSTICS CHART WITH SUBARU SELECT MONITOR

ABS (DIAGNOSTICS)

No.	Step	Check	Yes	No
1	CHECK GENERATOR. 1) Start engine. 2) Idling after warm-up. 3) Measure voltage between generator B terminal and chassis ground. <i>Terminal</i> Generator B terminal — Chassis ground:	Is the voltage between 10 and 15 V?	Go to step 2.	Repair generator. <Ref. to SC(H4)-15 Generator.>
2	CHECK BATTERY TERMINAL. Turn ignition switch to OFF.	Are the positive and negative battery terminals tightly clamped?	Go to step 3.	Tighten the clamp of terminal.
3	CHECK INPUT VOLTAGE OF ABSCM&H/U. 1) Disconnect connector from ABSCM&H/U. 2) Run the engine at idle. 3) Measure voltage between ABSCM&H/U connector and chassis ground. <i>Connector & terminal</i> (F49) No. 1 (+) — Chassis ground (-):	Is the voltage between 10 and 15 V?	Go to step 4.	Repair harness connector between battery, ignition switch and ABSCM&H/U.
4	CHECK GROUND CIRCUIT OF ABSCM&H/U. 1) Turn ignition switch to OFF. 2) Measure resistance between ABSCM&H/U connector and chassis ground. <i>Connector & terminal</i> (F49) No. 23 — Chassis ground:	Is the resistance less than 0.5 Ω ?	Go to step 5.	Repair ABSCM&H/U ground harness.
5	CHECK POOR CONTACT IN CONNECTORS.	Is there poor contact in connectors between generator, battery and ABSCM&H/U?	Repair connector.	Go to step 6.
6	CHECK ABSCM&H/U. 1) Connect all connectors. 2) Erase the memory. 3) Perform inspection mode. 4) Read out the trouble code.	Is the same trouble code as in the current diagnosis still being output?	Replace ABSCM&H/U. <Ref. to ABS-7 ABS Control Module and Hydraulic Control Unit (ABSCM&H/U).>	Go to step 7.
7	CHECK ANY OTHER TROUBLE CODES APPEARANCE.	Are other trouble codes being output?	Proceed with the diagnosis corresponding to the trouble code.	A temporary poor contact.

DIAGNOSTICS CHART WITH SUBARU SELECT MONITOR

ABS (DIAGNOSTICS)

V: TROUBLE CODE 42

— POWER SUPPLY VOLTAGE TOO HIGH — S006583D35

DIAGNOSIS:

- Power source voltage of the ABSCM&H/U is high.

TROUBLE SYMPTOM:

- ABS does not operate.

WIRING DIAGRAM:

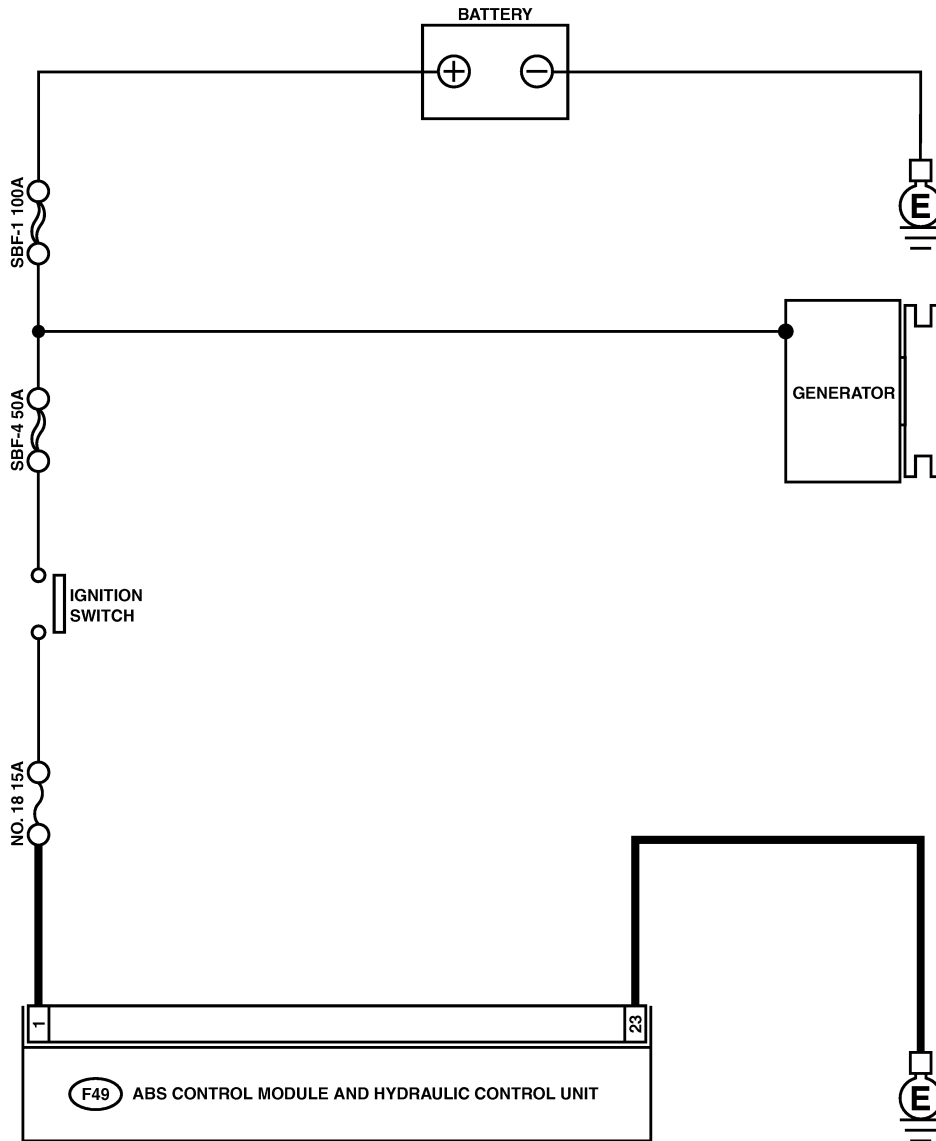

(F49)

1	2	3	4	5	6	7	8	9	10	11	12	13	14	15
16	17	18	19	20	21	22	23	24	25	26				
27	28	29	30	31										

B4M2334

DIAGNOSTICS CHART WITH SUBARU SELECT MONITOR

ABS (DIAGNOSTICS)

No.	Step	Check	Yes	No
1	CHECK GENERATOR. 1) Start engine. 2) Idling after warm-up. 3) Measure voltage between generator B terminal and chassis ground. <i>Terminal</i> Generator B terminal — Chassis ground:	Is the voltage between 10 and 17 V?	Go to step 2.	Repair generator. <Ref. to SC(H4)-15 Generator.>
2	CHECK BATTERY TERMINAL. Turn ignition switch to OFF.	Are the positive and negative battery terminals tightly clamped?	Go to step 3.	Tighten the clamp of terminal.
3	CHECK INPUT VOLTAGE OF ABSCM&H/U. 1) Disconnect connector from ABSCM&H/U. 2) Run the engine at idle. 3) Measure voltage between ABSCM&H/U connector and chassis ground. <i>Connector & terminal</i> (F49) No. 1 (+) — Chassis ground (-):	Is the voltage between 10 and 17 V?	Go to step 4.	Repair harness connector between battery, ignition switch and ABSCM&H/U.
4	CHECK GROUND CIRCUIT OF ABSCM&H/U. 1) Turn ignition switch to OFF. 2) Measure resistance between ABSCM&H/U connector and chassis ground. <i>Connector & terminal</i> (F49) No. 23 — Chassis ground:	Is the resistance less than 0.5 Ω?	Go to step 5.	Repair ABSCM&H/U ground harness.
5	CHECK POOR CONTACT IN CONNECTORS.	Is there poor contact in connectors between generator, battery and ABSCM&H/U?	Repair connector.	Go to step 6.
6	CHECK ABSCM&H/U. 1) Connect all connectors. 2) Erase the memory. 3) Perform inspection mode. 4) Read out the trouble code.	Is the same trouble code as in the current diagnosis still being output?	Replace ABSCM&H/U. <Ref. to ABS-7 ABS Control Module and Hydraulic Control Unit (ABSCM&H/U).>	Go to step 7.
7	CHECK ANY OTHER TROUBLE CODES APPEARANCE.	Are other trouble codes being output?	Proceed with the diagnosis corresponding to the trouble code.	A temporary poor contact.

DIAGNOSTICS CHART WITH SUBARU SELECT MONITOR

ABS (DIAGNOSTICS)

W: TROUBLE CODE 44

— ABS-AT CONTROL (NON CONTROLLED) — S006583E79

DIAGNOSIS:

- Combination of AT control faults

TROUBLE SYMPTOM:

- ABS does not operate.

WIRING DIAGRAM:

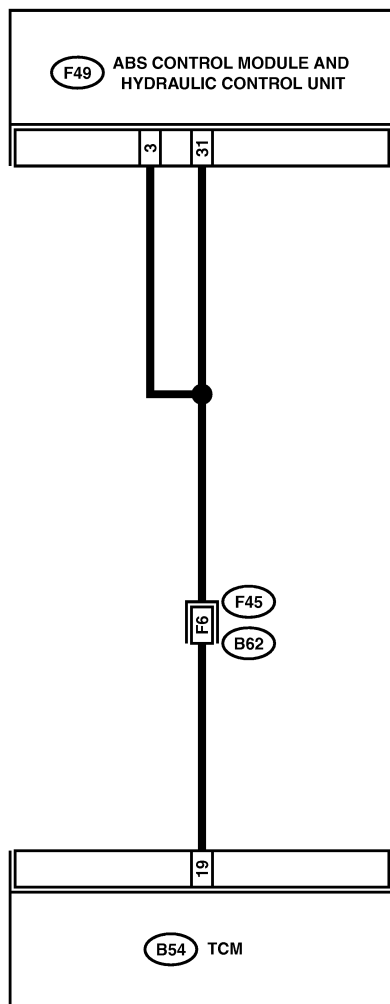

B54

1	2	3	4	5	6	7	8	9
10	11	12	13	14	15	16	17	18
19	20	21				22	23	24

F49

1	2	3	4	5	6	7	8	9	10	11	12	13	14	15
16	17	18	19	20	21	22	23	24	25	26				
27	28	29	30	31										

B62

A1	A2	A3	A4	A5	A6
B1	B2	B3	B4	B5	B6
C1	C2	C3	C4	C5	C6
D1	D2	D3	D4	D5	D6
E1	E2	E3	E4	E5	E6
F1					F6
G1					G6
H1					H6
I1					I6
J1					J6
K1					K6
L1	L2	L3	L4	L5	L6
M1	M2	M3	M4	M5	M6
N1	N2	N3	N4	N5	N6
O1	O2	O3	O4	O5	O6
P1	P2	P3	P4	P5	P6

B4M1458

DIAGNOSTICS CHART WITH SUBARU SELECT MONITOR

ABS (DIAGNOSTICS)

No.	Step	Check	Yes	No
1	CHECK SPECIFICATIONS OF THE ABSCM&H/U. Check specifications of the mark to the ABSCM&H/U. C5: AT (Except OUTBACK) C6: MT (Except OUTBACK) CE: AT (OUTBACK) CF: MT (OUTBACK)	Is an ABSCM&H/U for AT model installed on a MT model?	Replace ABSCM&H/U. <Ref. to ABS-7 ABS Control Module and Hydraulic Control Unit (ABSCM&H/U).>	Go to step 2.
2	CHECK GROUND SHORT OF HARNESS. 1) Turn ignition switch to OFF. 2) Disconnect two connectors from TCM. 3) Disconnect connector from ABSCM&H/U. 4) Measure resistance between ABSCM&H/U connector and chassis ground. Connector & terminal (F49) No. 3 — Chassis ground:	Is the resistance more than 1 MΩ?	Go to step 3.	Repair harness between TCM and ABSCM&H/U.
3	CHECK TCM. 1) Connect all connectors to TCM. 2) Turn ignition switch to ON. 3) Measure voltage between TCM connector terminal and chassis ground. Connector & terminal (B54) No. 19 (+) — Chassis ground (-):	Is the voltage between 10 and 15 V?	Go to step 5.	Go to step 4.
4	CHECK AT.	Is the AT functioning normally?	Replace TCM.	Repair AT.
5	CHECK OPEN CIRCUIT OF HARNESS. Measure voltage between ABSCM&H/U connector and chassis ground. Connector & terminal (F49) No. 3 (+) — Chassis ground (-): (F49) No. 31 (+) — Chassis ground (-):	Is the voltage more than 10 V?	Go to step 6.	Repair harness/connector between TCM and ABSCM&H/U.
6	CHECK POOR CONTACT IN CONNECTORS.	Is there poor contact in connectors between TCM and ABSCM&H/U?	Repair connector.	Go to step 7.
7	CHECK ABSCM&H/U. 1) Connect all connectors. 2) Erase the memory. 3) Perform inspection mode. 4) Read out the trouble code.	Is the same trouble code as in the current diagnosis still being output?	Replace ABSCM&H/U. <Ref. to ABS-7 ABS Control Module and Hydraulic Control Unit (ABSCM&H/U).>	Go to step 8.
8	CHECK ANY OTHER TROUBLE CODES APPEARANCE.	Are other trouble codes being output?	Proceed with the diagnosis corresponding to the trouble code.	A temporary poor contact.

DIAGNOSTICS CHART WITH SUBARU SELECT MONITOR

ABS (DIAGNOSTICS)

X: TROUBLE CODE 44

— ABS-AT CONTROL (CONTROLLED) — S006583E80

DIAGNOSIS:

- Combination of AT control faults

TROUBLE SYMPTOM:

- ABS does not operate.

WIRING DIAGRAM:

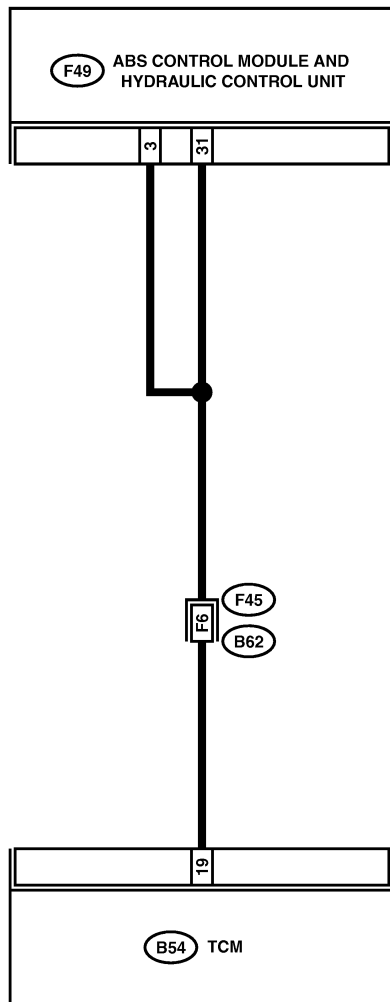

B54

1	2	3	4	5	6	7	8	9
10	11	12	13	14	15	16	17	18
19	20	21				22	23	24

F49

1	2	3	4	5	6	7	8	9	10	11	12	13	14	15
16	17	18	19	20	21	22	23	24	25	26				
27	28	29	30	31										

B62

A1	A2	A3	A4	A5	A6
B1	B2	B3	B4	B5	B6
C1	C2	C3	C4	C5	C6
D1	D2		D4	D5	D6
E1	E2		E4	E5	E6
F1					F6
G1					G6
H1					H6
I1					I6
J1					J6
K1					K6
L1	L2		L4	L5	L6
M1	M2	N3	M4	M5	M6
N1	N2	O3	N4	N5	N6
O1	O2		O4	O5	O6
P1	P2	P3	P4	P5	P6

B4M1458

DIAGNOSTICS CHART WITH SUBARU SELECT MONITOR

ABS (DIAGNOSTICS)

No.	Step	Check	Yes	No
1	CHECK BATTERY SHORT OF HARNESS. 1) Turn ignition switch to OFF. 2) Disconnect two connectors from TCM. 3) Disconnect connector from ABSCM&H/U. 4) Measure voltage between ABSCM&H/U connector and chassis ground. Connector & terminal (F49) No. 3 (+) — Chassis ground (-):	Is the voltage less than 1 V?	Go to step 2.	Repair harness between TCM and ABSCM&H/U.
2	CHECK BATTERY SHORT OF HARNESS. 1) Turn ignition switch to ON. 2) Measure voltage between ABSCM&H/U connector and chassis ground. Connector & terminal (F49) No. 3 (+) — Chassis ground (-):	Is the voltage less than 1 V?	Go to step 3.	Repair harness between TCM and ABSCM&H/U.
3	CHECK OPEN CIRCUIT OF HARNESS. 1) Turn ignition switch to OFF. 2) Connect all connectors to TCM. 3) Turn ignition switch to ON. 4) Measure voltage between ABSCM&H/U connector and chassis ground. Connector & terminal (F49) No. 3 (+) — Chassis ground (-): (F49) No. 31 (+) — Chassis ground (-):	Is the voltage between 10 and 13 V?	Go to step 4.	Repair harness/connector between TCM and ABSCM&H/U.
4	CHECK POOR CONTACT IN CONNECTORS. Turn ignition switch to OFF.	Is there poor contact in connectors between TCM and ABSCM&H/U?	Repair connector.	Go to step 5.
5	CHECK ABSCM&H/U. 1) Connect all connectors. 2) Erase the memory. 3) Perform inspection mode. 4) Read out the trouble code.	Is the same trouble code as in the current diagnosis still being output?	Replace ABSCM&H/U. <Ref. to ABS-7 ABS Control Module and Hydraulic Control Unit (ABSCM&H/U).>	Go to step 6.
6	CHECK ANY OTHER TROUBLE CODES APPEARANCE.	Are other trouble codes being output?	Proceed with the diagnosis corresponding to the trouble code.	A temporary poor contact.

DIAGNOSTICS CHART WITH SUBARU SELECT MONITOR

ABS (DIAGNOSTICS)

Y: TROUBLE CODE 51 — VALVE RELAY MALFUNCTION —

S006583E81

DIAGNOSIS:

- Faulty valve relay

TROUBLE SYMPTOM:

- ABS does not operate.

WIRING DIAGRAM:

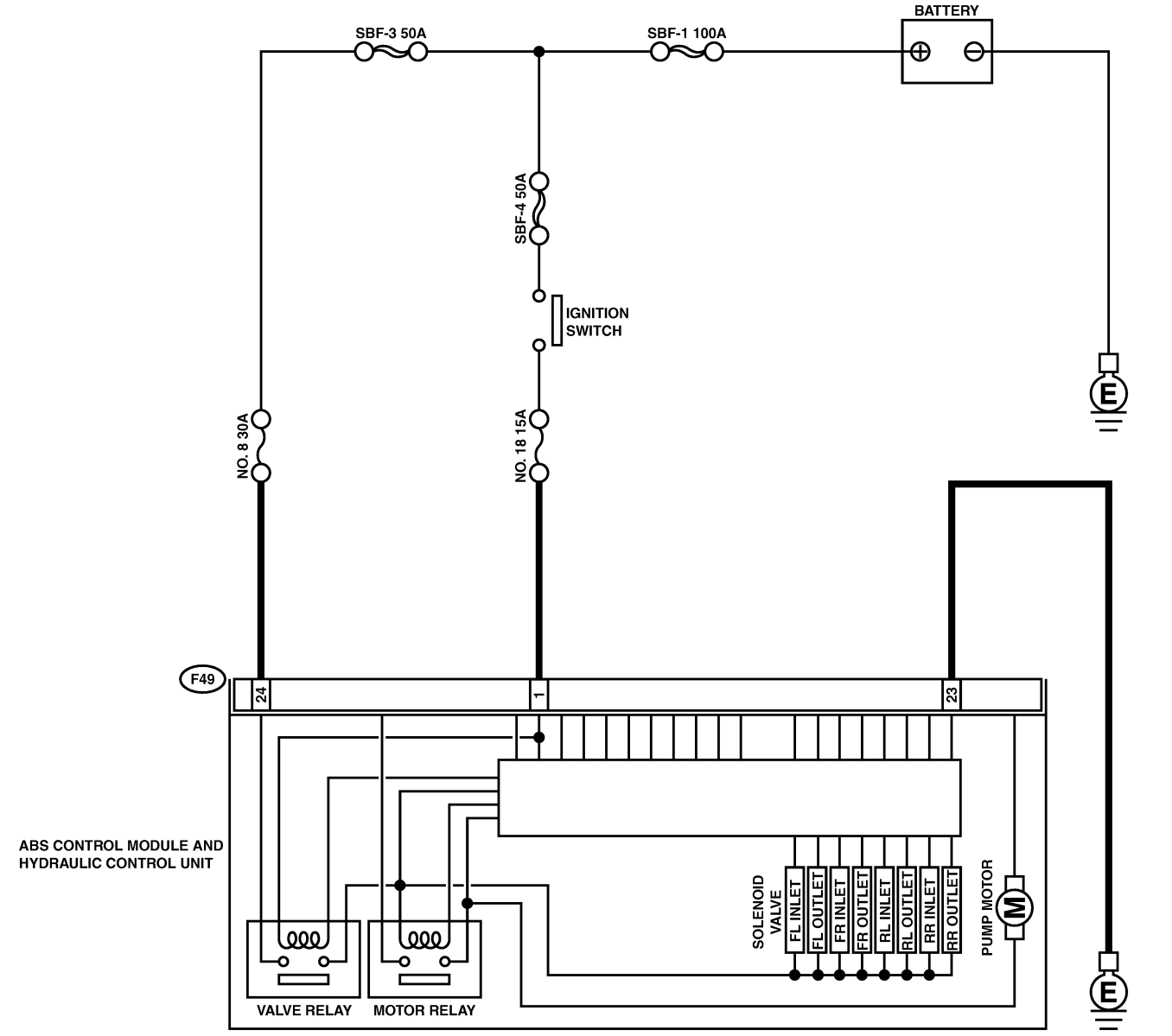

F49

1	2	3	4	5	6	7	8	9	10	11	12	13	14	15
16	17	18	19	20	21	22	23	24	25	26				
27	28	29	30	31										

B4M1459

ABS-130

DIAGNOSTICS CHART WITH SUBARU SELECT MONITOR

ABS (DIAGNOSTICS)

No.	Step	Check	Yes	No
1	CHECK INPUT VOLTAGE OF ABSCM&H/U. 1) Turn ignition switch to OFF. 2) Disconnect connector from ABSCM&H/U. 3) Run the engine at idle. 4) Measure voltage between ABSCM&H/U connector and chassis ground. Connector & terminal <i>(F49) No. 1 (+) — Chassis ground (-):</i> <i>(F49) No. 24 (+) — Chassis ground (-):</i>	Is the voltage between 10 and 15 V?	Go to step 2.	Repair harness connector between battery and ABSCM&H/U.
2	CHECK GROUND CIRCUIT OF ABSCM&H/U. 1) Turn ignition switch to OFF. 2) Measure resistance between ABSCM&H/U connector and chassis ground. Connector & terminal <i>(F49) No. 23 — Chassis ground:</i>	Is the resistance less than 0.5 Ω ?	Go to step 3.	Repair ABSCM&H/U ground harness.
3	CHECK POOR CONTACT IN CONNECTORS.	Is there poor contact in connectors between generator, battery and ABSCM&H/U?	Repair connector.	Go to step 4.
4	CHECK ABSCM&H/U. 1) Connect all connectors. 2) Erase the memory. 3) Perform inspection mode. 4) Read out the trouble code.	Is the same trouble code as in the current diagnosis still being output?	Replace ABSCM&H/U. <Ref. to ABS-7 ABS Control Module and Hydraulic Control Unit (ABSCM&H/U).>	Go to step 5.
5	CHECK ANY OTHER TROUBLE CODES APPEARANCE.	Are other trouble codes being output?	Proceed with the diagnosis corresponding to the trouble code.	A temporary poor contact.

DIAGNOSTICS CHART WITH SUBARU SELECT MONITOR

ABS (DIAGNOSTICS)

Z: TROUBLE CODE 51 — VALVE RELAY ON FAILURE —

S006583D63

DIAGNOSIS:

- Faulty valve relay

TROUBLE SYMPTOM:

- ABS does not operate.

WIRING DIAGRAM:

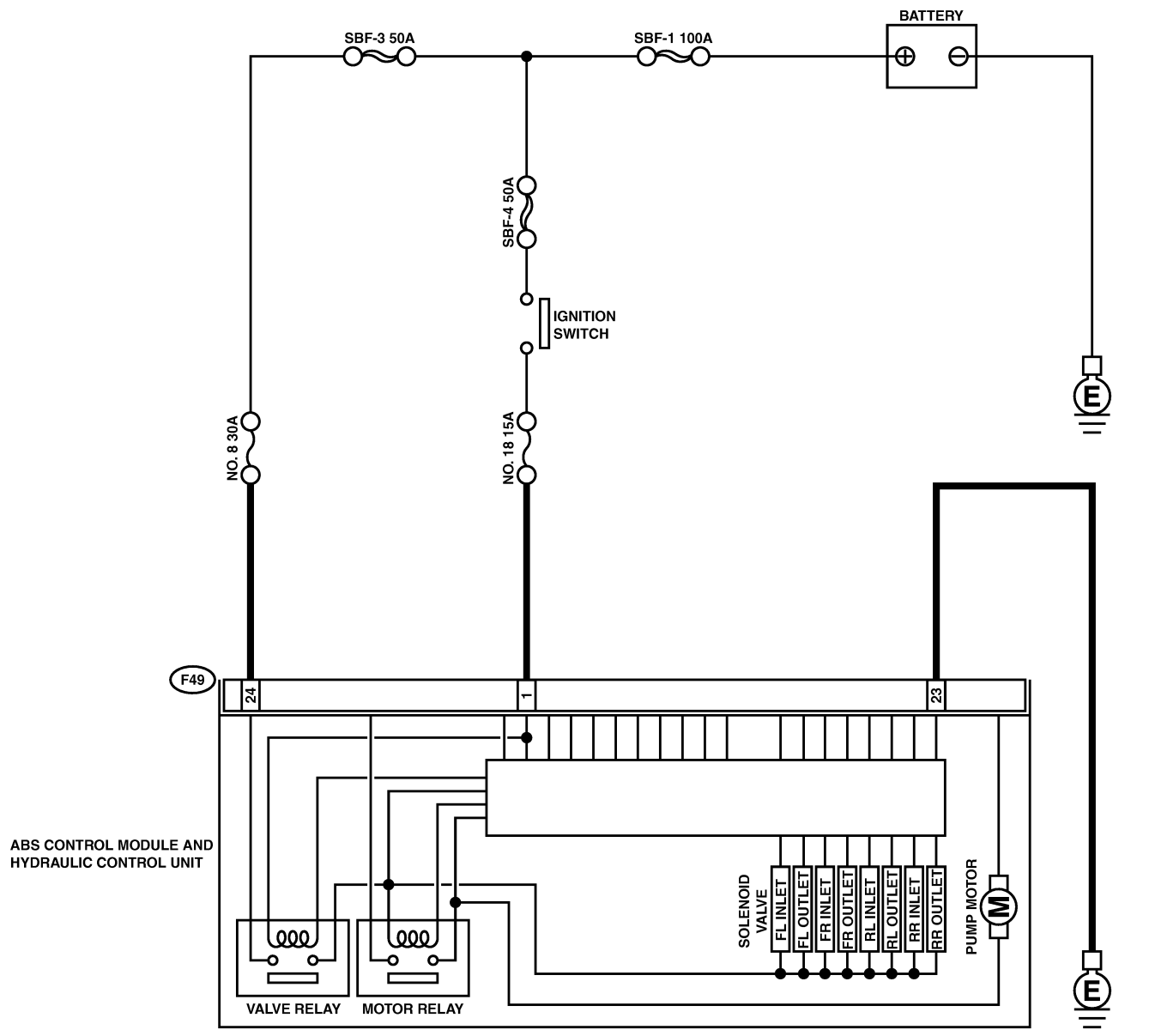

F49

1	2	3	4	5	6	7	8	9	10	11	12	13	14	15
16	17	18	19	20	21	22	23	24	25	26				
27	28	29	30	31										

B4M1459

DIAGNOSTICS CHART WITH SUBARU SELECT MONITOR

ABS (DIAGNOSTICS)

No.	Step	Check	Yes	No
1	CHECK VALVE RELAY IN ABSCM&H/U. Measure resistance between ABSCM&H/U terminals. <i>Terminals</i> No. 23 (+) — No. 24 (-):	Is the resistance more than 1 MΩ?	Go to step 2.	Replace ABSCM&H/U. <Ref. to ABS-7 ABS Control Module and Hydraulic Control Unit (ABSCM&H/U).>
2	CHECK POOR CONTACT IN CONNECTORS.	Is there poor contact in connectors between generator, battery and ABSCM&H/U?	Repair connector.	Go to step 3.
3	CHECK ABSCM&H/U. 1) Connect all connectors. 2) Erase the memory. 3) Perform inspection mode. 4) Read out the trouble code.	Is the same trouble code as in the current diagnosis still being output?	Replace ABSCM&H/U. <Ref. to ABS-7 ABS Control Module and Hydraulic Control Unit (ABSCM&H/U).>	Go to step 4.
4	CHECK ANY OTHER TROUBLE CODES APPEARANCE.	Are other trouble codes being output?	Proceed with the diagnosis corresponding to the trouble code.	A temporary poor contact.

DIAGNOSTICS CHART WITH SUBARU SELECT MONITOR

ABS (DIAGNOSTICS)

AA: TROUBLE CODE 52

— OPEN CIRCUIT IN MOTOR RELAY CIRCUIT — S006583E82

DIAGNOSIS:

- Faulty motor
- Faulty motor relay
- Faulty harness connector

TROUBLE SYMPTOM:

- ABS does not operate.

DIAGNOSTICS CHART WITH SUBARU SELECT MONITOR

ABS (DIAGNOSTICS)

WIRING DIAGRAM:

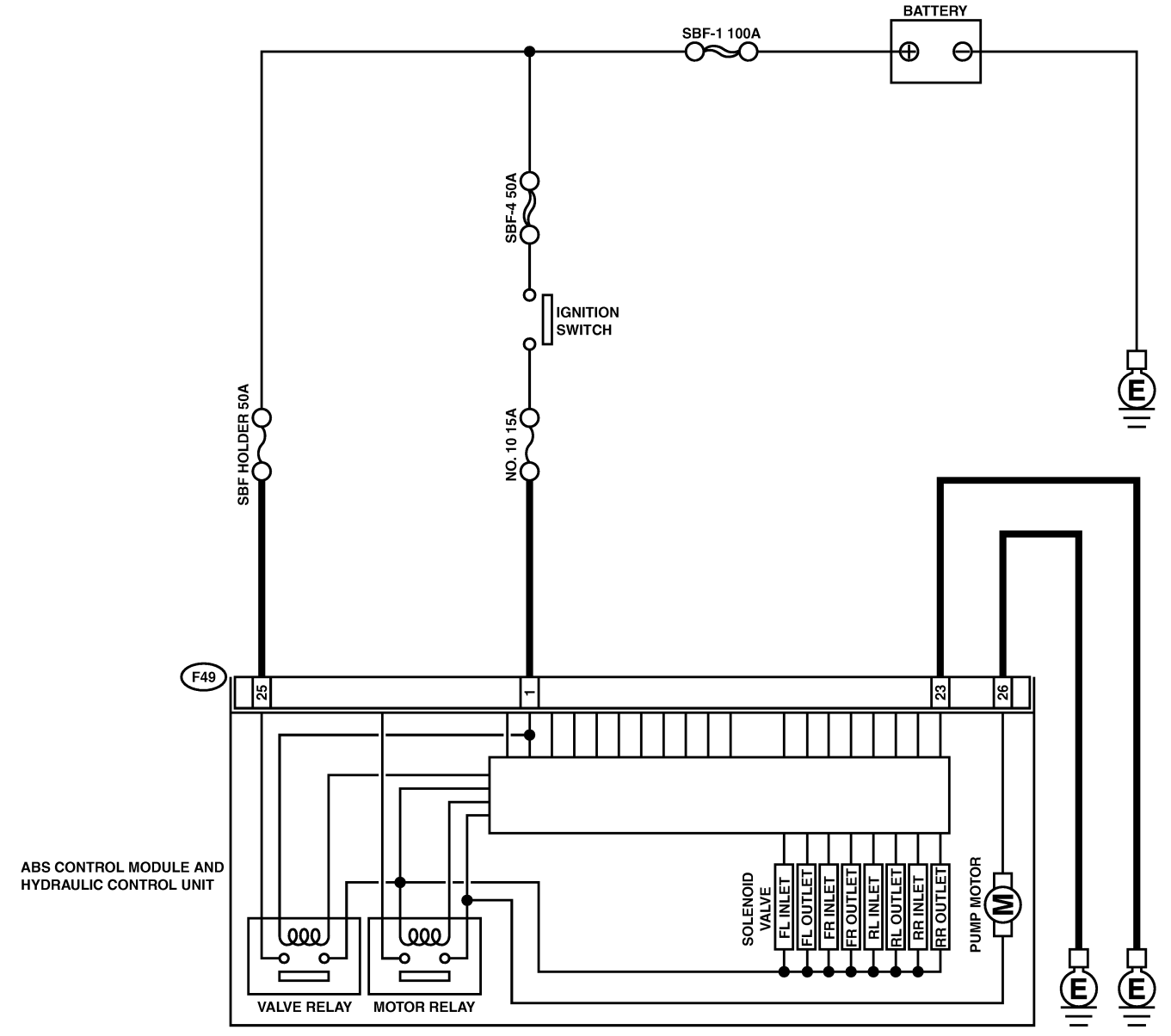

ABS CONTROL MODULE AND HYDRAULIC CONTROL UNIT

F49

1	2	3	4	5	6	7	8	9	10	11	12	13	14	15
16	17	18	19	20	21	22		23	24	25	26			
27	28	29	30	31										

B4M1460

ABS-135

DIAGNOSTICS CHART WITH SUBARU SELECT MONITOR

ABS (DIAGNOSTICS)

No.	Step	Check	Yes	No
1	CHECK INPUT VOLTAGE OF ABSCM&H/U. 1) Turn ignition switch to OFF. 2) Disconnect connector from ABSCM&H/U. 3) Turn ignition switch to ON. 4) Measure voltage between ABSCM&H/U connector and chassis ground. Connector & terminal (F49) No. 25 (+) — Chassis ground (-):	Is the voltage between 10 and 13 V?	Go to step 2.	Repair harness/connector between battery and ABSCM&H/U and check fuse SBF6.
2	CHECK GROUND CIRCUIT OF MOTOR. 1) Turn ignition switch to OFF. 2) Measure resistance between ABSCM&H/U connector and chassis ground. Connector & terminal (F49) No. 26 — Chassis ground:	Is the resistance less than 0.5 Ω?	Go to step 3.	Repair ABSCM&H/U ground harness.
3	CHECK MOTOR OPERATION. Operate the sequence control. <Ref. to ABS-11 ABS Sequence Control.> NOTE: Use the diagnosis connector to operate the sequence control.	Can motor revolution noise (buzz) be heard when carrying out the check sequence?	Go to step 4.	Replace ABSCM&H/U. <Ref. to ABS-7 ABS Control Module and Hydraulic Control Unit (ABSCM&H/U).>
4	CHECK POOR CONTACT IN CONNECTORS. Turn ignition switch to OFF.	Is there poor contact in connector between hydraulic unit, relay box and ABSCM&H/U?	Repair connector.	Go to step 5.
5	CHECK ABSCM&H/U. 1) Connect all connectors. 2) Erase the memory. 3) Perform inspection mode. 4) Read out the trouble code.	Is the same trouble code as in the current diagnosis still being output?	Replace ABSCM&H/U. <Ref. to ABS-7 ABS Control Module and Hydraulic Control Unit (ABSCM&H/U).>	Go to step 6.
6	CHECK ANY OTHER TROUBLE CODES APPEARANCE.	Are other trouble codes being output?	Proceed with the diagnosis corresponding to the trouble code.	A temporary poor contact.

DIAGNOSTICS CHART WITH SUBARU SELECT MONITOR

ABS (DIAGNOSTICS)

MEMO:

ABS-137

DIAGNOSTICS CHART WITH SUBARU SELECT MONITOR

ABS (DIAGNOSTICS)

AB: TROUBLE CODE 52 **— MOTOR RELAY ON FAILURE —** S006583E83

DIAGNOSIS:

- Faulty motor
- Faulty motor relay
- Faulty harness connector

TROUBLE SYMPTOM:

- ABS does not operate.

DIAGNOSTICS CHART WITH SUBARU SELECT MONITOR

ABS (DIAGNOSTICS)

WIRING DIAGRAM:

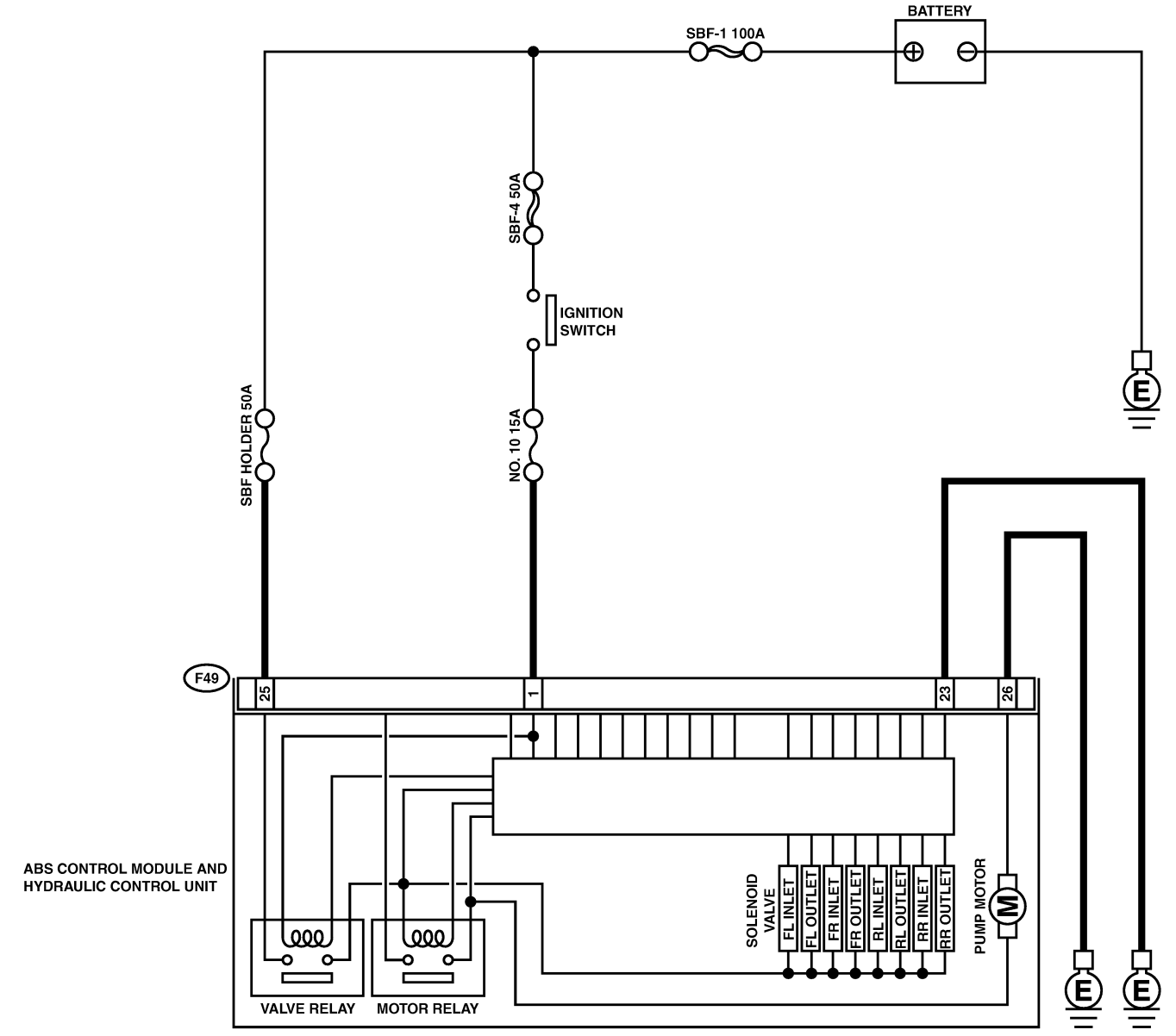

F49

1	2	3	4	5	6	7	8	9	10	11	12	13	14	15
16	17	18	19	20	21	22								
27	28	29	30	31				23	24	25	26			

B4M1460

ABS-139

DIAGNOSTICS CHART WITH SUBARU SELECT MONITOR

ABS (DIAGNOSTICS)

No.	Step	Check	Yes	No
1	CHECK MOTOR RELAY IN ABSCM&H/U. Measure resistance between ABSCM&H/U terminals. <i>Terminals</i> No. 25 — No. 26:	Is the resistance more than 1 MΩ?	Go to step 2.	Replace ABSCM&H/U. <Ref. to ABS-7 ABS Control Module and Hydraulic Control Unit (ABSCM&H/U).>
2	CHECK MOTOR OPERATION. Operate the sequence control. <Ref. to ABS-11 ABS Sequence Control.> NOTE: Use the diagnosis connector to operate the sequence control.	Can motor revolution noise (buzz) be heard when carrying out the sequence control?	Go to step 3.	Replace ABSCM&H/U. <Ref. to ABS-7 ABS Control Module and Hydraulic Control Unit (ABSCM&H/U).>
3	CHECK POOR CONTACT IN CONNECTORS. Turn ignition switch to OFF.	Is there poor contact in connector between hydraulic unit, relay box and ABSCM&H/U?	Repair connector.	Go to step 4.
4	CHECK ABSCM&H/U. 1) Connect all connectors. 2) Erase the memory. 3) Perform inspection mode. 4) Read out the trouble code.	Is the same trouble code as in the current diagnosis still being output?	Replace ABSCM&H/U. <Ref. to ABS-7 ABS Control Module and Hydraulic Control Unit (ABSCM&H/U).>	Go to step 5.
5	CHECK ANY OTHER TROUBLE CODES APPEARANCE.	Are other trouble codes being output?	Proceed with the diagnosis corresponding to the trouble code.	A temporary poor contact.

DIAGNOSTICS CHART WITH SUBARU SELECT MONITOR

ABS (DIAGNOSTICS)

MEMO:

ABS-141

DIAGNOSTICS CHART WITH SUBARU SELECT MONITOR

ABS (DIAGNOSTICS)

AC: TROUBLE CODE 52 — MOTOR MALFUNCTION — S006583D68

DIAGNOSIS:

- Faulty motor
- Faulty motor relay
- Faulty harness connector

TROUBLE SYMPTOM:

- ABS does not operate.

DIAGNOSTICS CHART WITH SUBARU SELECT MONITOR

ABS (DIAGNOSTICS)

WIRING DIAGRAM:

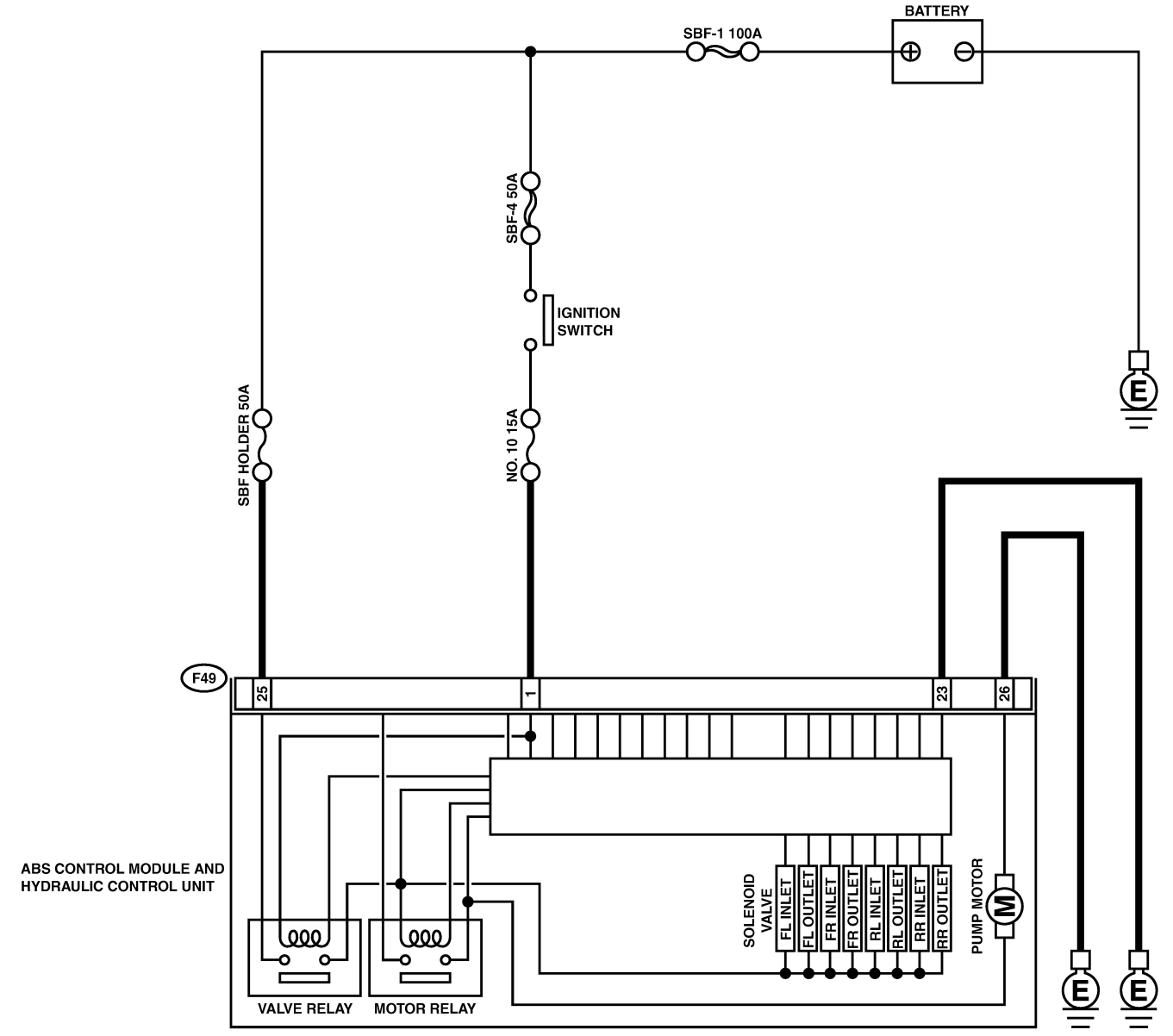

F49

1	2	3	4	5	6	7	8	9	10	11	12	13	14	15
16	17	18	19	20	21	22		23	24	25	26			
27	28	29	30	31										

B4M1460

ABS-143

DIAGNOSTICS CHART WITH SUBARU SELECT MONITOR

ABS (DIAGNOSTICS)

No.	Step	Check	Yes	No
1	CHECK INPUT VOLTAGE OF ABSCM&H/U. 1) Turn ignition switch to OFF. 2) Disconnect connector from ABSCM&H/U. 3) Turn ignition switch to ON. 4) Measure voltage between ABSCM&H/U connector and chassis ground. Connector & terminal (F49) No. 25 (+) — Chassis ground (-):	Is the voltage between 10 and 13 V?	Go to step 2.	Repair harness/connector between battery and ABSCM&H/U and check fuse SBF6.
2	CHECK GROUND CIRCUIT OF MOTOR. 1) Turn ignition switch to OFF. 2) Measure resistance between ABSCM&H/U connector and chassis ground. Connector & terminal (F49) No. 26 — Chassis ground:	Is the resistance less than 0.5 Ω?	Go to step 3.	Repair ABSCM&H/U ground harness.
3	CHECK INPUT VOLTAGE OF ABSCM&H/U. 1) Run the engine at idle. 2) Measure voltage between ABSCM&H/U connector and chassis ground. Connector & terminal (F49) No. 1 (+) — Chassis ground (-):	Is the voltage between 10 and 15 V?	Go to step 4.	Repair harness connector between battery, ignition switch and ABSCM&H/U.
4	CHECK GROUND CIRCUIT OF ABSCM&H/U. 1) Turn ignition switch to OFF. 2) Measure resistance between ABSCM&H/U connector and chassis ground. Connector & terminal (F49) No. 23 — Chassis ground:	Is the resistance less than 0.5 Ω?	Go to step 5.	Repair ABSCM&H/U ground harness.
5	CHECK MOTOR OPERATION. Operate the sequence control. <Ref. to ABS-11 ABS Sequence Control.> NOTE: Use the diagnosis connector to operate the sequence control.	Can motor revolution noise (buzz) be heard when carrying out the sequence control?	Go to step 6.	Replace ABSCM&H/U. <Ref. to ABS-7 ABS Control Module and Hydraulic Control Unit (ABSCM&H/U).>
6	CHECK POOR CONTACT IN CONNECTORS. Turn ignition switch to OFF.	Is there poor contact in connector between generator, battery and ABSCM&H/U?	Repair connector.	Go to step 7.
7	CHECK ABSCM&H/U. 1) Connect all connectors. 2) Erase the memory. 3) Perform inspection mode. 4) Read out the trouble code.	Is the same trouble code as in the current diagnosis still being output?	Replace ABSCM&H/U. <Ref. to ABS-7 ABS Control Module and Hydraulic Control Unit (ABSCM&H/U).>	Go to step 8.
8	CHECK ANY OTHER TROUBLE CODES APPEARANCE.	Are other trouble codes being output?	Proceed with the diagnosis corresponding to the trouble code.	A temporary poor contact.

DIAGNOSTICS CHART WITH SUBARU SELECT MONITOR

ABS (DIAGNOSTICS)

MEMO:

ABS-145

DIAGNOSTICS CHART WITH SUBARU SELECT MONITOR

ABS (DIAGNOSTICS)

AD: TROUBLE CODE 54

— STOP LIGHT SWITCH SIGNAL CIRCUIT MALFUNCTION —

S006583E84

DIAGNOSIS:

- Faulty stop light switch

TROUBLE SYMPTOM:

- ABS does not operate.

WIRING DIAGRAM:

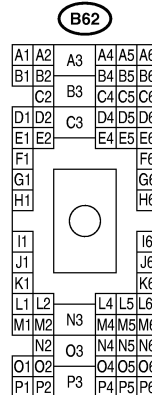
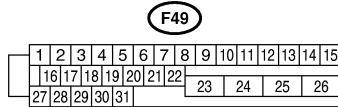
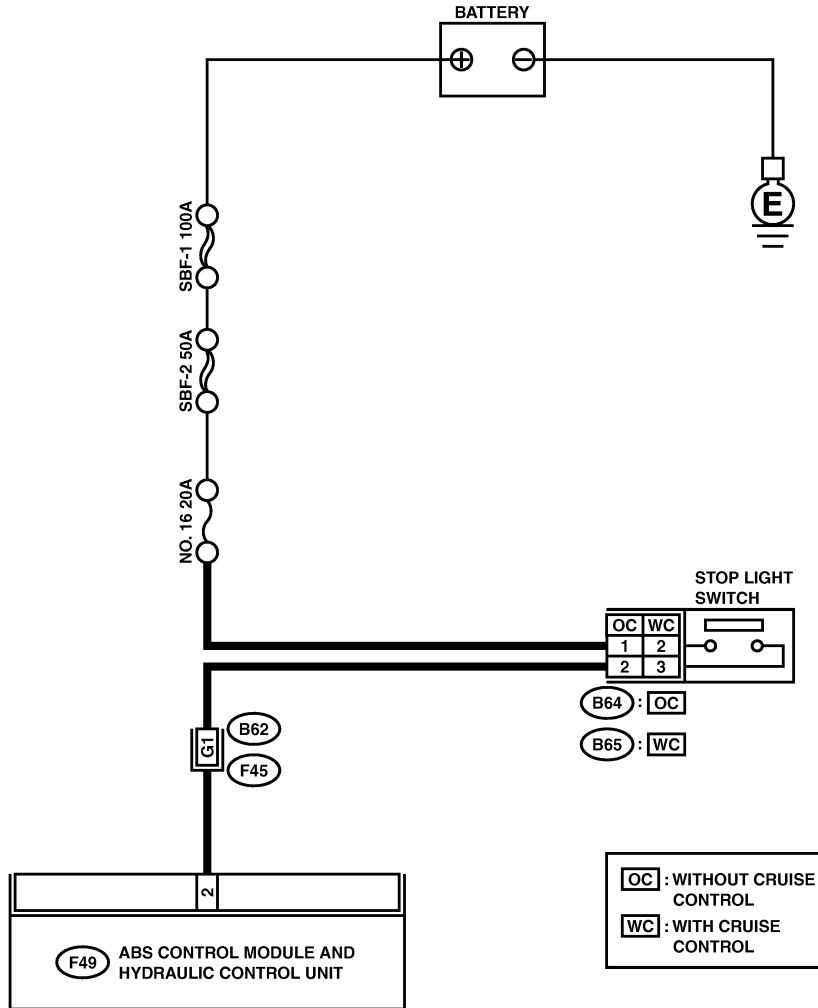

B4M1461

DIAGNOSTICS CHART WITH SUBARU SELECT MONITOR

ABS (DIAGNOSTICS)

No.	Step	Check	Yes	No
1	CHECK OUTPUT OF STOP LIGHT SWITCH USING SELECT MONITOR. 1) Select "Current data display & Save" on the select monitor. 2) Release the brake pedal. 3) Read the stop light switch output in the select monitor data display.	Is the reading indicated on monitor display less than 1.5 V?	Go to step 2.	Go to step 3.
2	CHECK OUTPUT OF STOP LIGHT SWITCH USING SELECT MONITOR. 1) Depress the brake pedal. 2) Read the stop light switch output in the select monitor data display.	Is the reading indicated on monitor display between 10 and 15 V?	Go to step 5.	Go to step 3.
3	CHECK IF STOP LIGHTS COME ON. Depress the brake pedal.	Do stop lights turn on?	Go to step 4.	Repair stop lights circuit.
4	CHECK OPEN CIRCUIT IN HARNESS. 1) Turn ignition switch to OFF. 2) Disconnect connector from ABSCM&H/U. 3) Depress brake pedal. 4) Measure voltage between ABSCM&H/U connector and chassis ground. <i>Connector & terminal</i> <i>(F49) No. 2 — Chassis ground:</i>	Is the voltage between 10 and 15 V?	Go to step 5.	Repair harness between stop light switch and ABSCM&H/U connector.
5	CHECK POOR CONTACT IN CONNECTORS.	Is there poor contact in connector between stop light switch and ABSCM&H/U?	Repair connector.	Go to step 6.
6	CHECK ABSCM&H/U. 1) Connect all connectors. 2) Erase the memory. 3) Perform inspection mode. 4) Read out the trouble code.	Is the same trouble code as in the current diagnosis still being output?	Replace ABSCM&H/U. <Ref. to ABS-7 ABS Control Module and Hydraulic Control Unit (ABSCM&H/U).>	Go to step 7.
7	CHECK ANY OTHER TROUBLE CODES APPEARANCE.	Are other trouble codes being output?	Proceed with the diagnosis corresponding to the trouble code.	A temporary poor contact.

DIAGNOSTICS CHART WITH SUBARU SELECT MONITOR

ABS (DIAGNOSTICS)

AE: TROUBLE CODE 56

— OPEN OR SHORT CIRCUIT IN G SENSOR CIRCUIT — S006583E85

DIAGNOSIS:

- Faulty G sensor output voltage

TROUBLE SYMPTOM:

- ABS does not operate.

WIRING DIAGRAM:

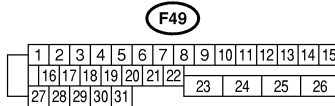
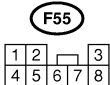
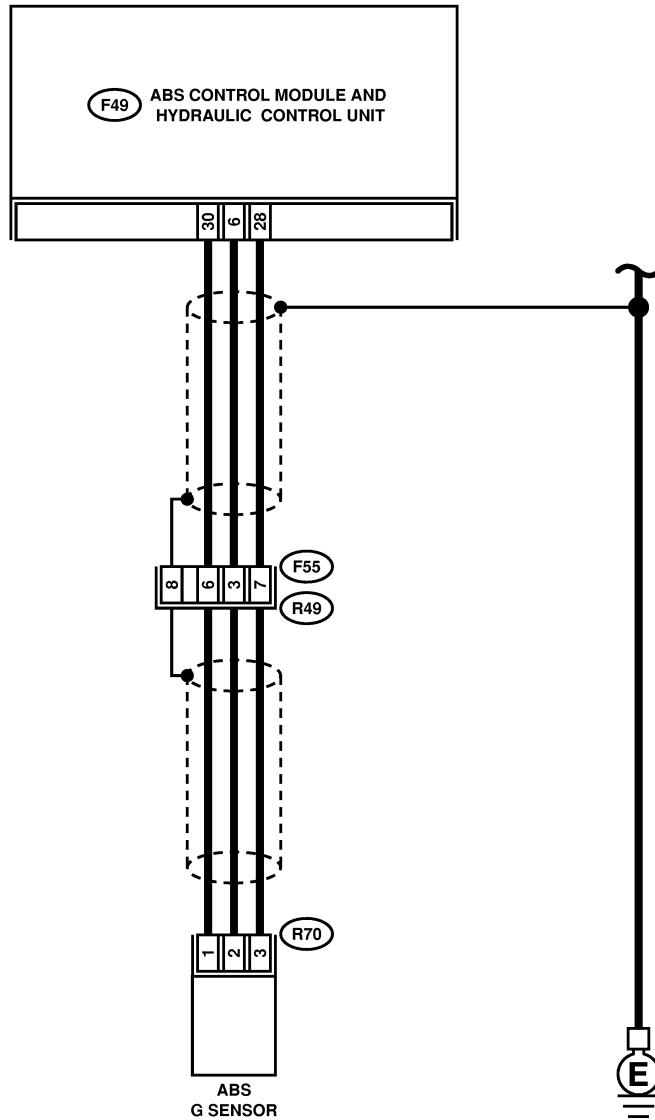

B4M1462

DIAGNOSTICS CHART WITH SUBARU SELECT MONITOR

ABS (DIAGNOSTICS)

No.	Step	Check	Yes	No
1	CHECK OUTPUT OF G SENSOR USING SELECT MONITOR. 1) Select "Current data display & Save" on the select monitor. 2) Read the G sensor output in select monitor data display.	Is the G sensor output on the monitor display between 2.1 and 2.5 V when the G sensor is in horizontal position?	Go to step 2.	Go to step 5.
2	CHECK POOR CONTACT IN CONNECTORS.	Is there poor contact in connector between ABSCM&H/U and G sensor?	Repair connector.	Go to step 3.
3	CHECK ABSCM&H/U. 1) Connect all connectors. 2) Erase the memory. 3) Perform inspection mode. 4) Read out the trouble code.	Is the same trouble code as in the current diagnosis still being output?	Replace ABSCM&H/U. <Ref. to ABS-7 ABS Control Module and Hydraulic Control Unit (ABSCM&H/U).>	Go to step 4.
4	CHECK ANY OTHER TROUBLE CODES APPEARANCE.	Are other trouble codes being output?	Proceed with the diagnosis corresponding to the trouble code.	A temporary poor contact.
5	CHECK INPUT VOLTAGE OF G SENSOR. 1) Turn ignition switch to OFF. 2) Remove console box. 3) Disconnect G sensor from body. (Do not disconnect connector.) 4) Turn ignition switch to ON. 5) Measure voltage between G sensor connector terminals. Connector & terminal (R70) No. 1 (+) — No. 3 (-):	Is the voltage between 4.75 and 5.25 V?	Go to step 6.	Repair harness/connector between G sensor and ABSCM&H/U.
6	CHECK OPEN CIRCUIT IN G SENSOR OUTPUT HARNESS AND GROUND HARNESS. 1) Turn ignition switch to OFF. 2) Disconnect connector from ABSCM&H/U. 3) Measure resistance between ABSCM&H/U connector terminals. Connector & terminal (F49) No. 6 — No. 28:	Is the resistance between 4.3 and 4.9 k Ω ?	Go to step 7.	Repair harness/connector between G sensor and ABSCM&H/U.
7	CHECK GROUND SHORT IN G SENSOR OUTPUT HARNESS. 1) Disconnect connector from G sensor. 2) Measure resistance between ABSCM&H/U connector and chassis ground. Connector & terminal (F49) No. 6 — Chassis ground:	Is the resistance more than 1 M Ω ?	Go to step 8.	Repair harness between G sensor and ABSCM&H/U.
8	CHECK G SENSOR. 1) Connect connector to G sensor. 2) Connect connector to ABSCM&H/U. 3) Turn ignition switch to ON. 4) Measure voltage between G sensor connector terminals. Connector & terminal (R70) No. 2 (+) — No. 3 (-):	Is the voltage between 2.1 and 2.5 V when G sensor is horizontal?	Go to step 9.	Replace G sensor. <Ref. to ABS-24 G Sensor.>
9	CHECK G SENSOR. Measure voltage between G sensor connector terminals. Connector & terminal (R70) No. 2 (+) — No. 3 (-):	Is the voltage between 3.7 and 4.1 V when G sensor is inclined forwards to 90°?	Go to step 10.	Replace G sensor. <Ref. to ABS-24 G Sensor.>

DIAGNOSTICS CHART WITH SUBARU SELECT MONITOR

ABS (DIAGNOSTICS)

No.	Step	Check	Yes	No
10	CHECK G SENSOR. Measure voltage between G sensor connector terminals. <i>Connector & terminal (R70) No. 2 (+) — No. 3 (-):</i>	Is the voltage between 0.5 and 0.9 V when G sensor is inclined backwards to 90°?	Go to step 11.	Replace G sensor. <Ref. to ABS-24 G Sensor.>
11	CHECK POOR CONTACT IN CONNECTORS. Turn ignition switch to OFF.	Is there poor contact in connector between ABSCM&H/U and G sensor?	Repair connector.	Go to step 12.
12	CHECK ABSCM&H/U. 1) Connect all connectors. 2) Erase the memory. 3) Perform inspection mode. 4) Read out the trouble code.	Is the same trouble code as in the current diagnosis still being output?	Replace ABSCM&H/U. <Ref. to ABS-7 ABS Control Module and Hydraulic Control Unit (ABSCM&H/U).>	Go to step 13.
13	CHECK ANY OTHER TROUBLE CODES APPEARANCE.	Are other trouble codes being output?	Proceed with the diagnosis corresponding to the trouble code.	A temporary poor contact.

DIAGNOSTICS CHART WITH SUBARU SELECT MONITOR

ABS (DIAGNOSTICS)

MEMO:

ABS-151

DIAGNOSTICS CHART WITH SUBARU SELECT MONITOR

ABS (DIAGNOSTICS)

AF: TROUBLE CODE 56

— BATTERY SHORT IN G SENSOR CIRCUIT — S006583E86

DIAGNOSIS:

- Faulty G sensor output voltage

TROUBLE SYMPTOM:

- ABS does not operate.

WIRING DIAGRAM:

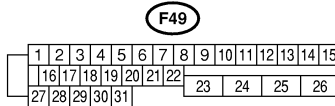
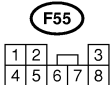
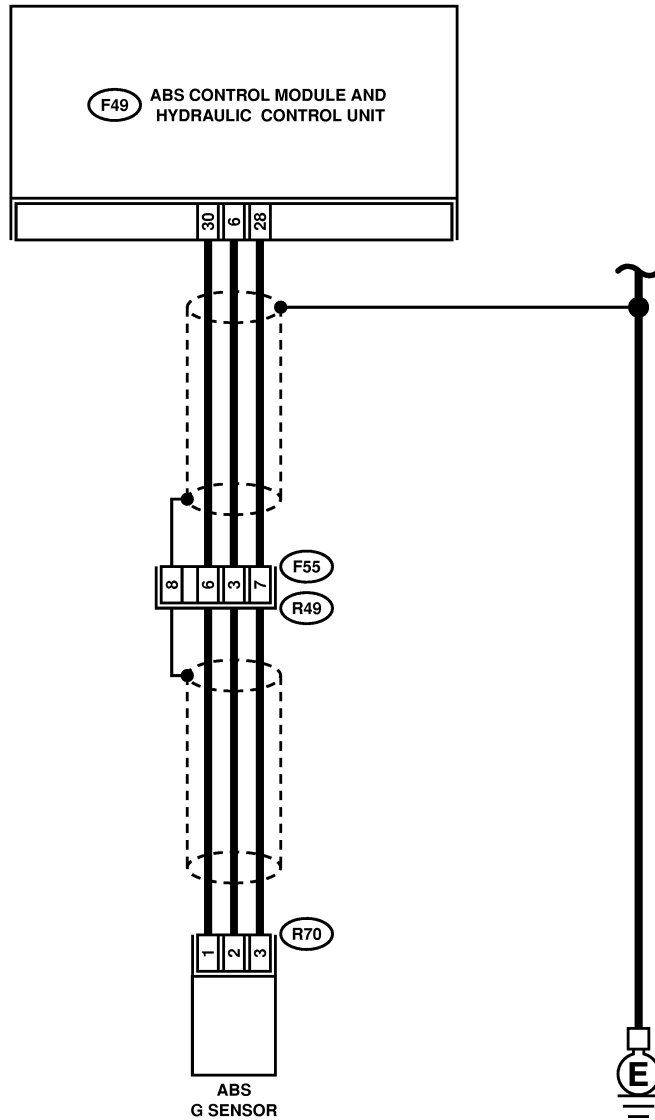

B4M1462

DIAGNOSTICS CHART WITH SUBARU SELECT MONITOR

ABS (DIAGNOSTICS)

No.	Step	Check	Yes	No
1	CHECK OUTPUT OF G SENSOR USING SELECT MONITOR. 1) Select "Current data display & Save" on the select monitor. 2) Read the G sensor output in select monitor data display.	Is the G sensor output on the monitor display between 2.1 and 2.5 V when the G sensor is in horizontal position?	Go to step 2.	Go to step 5.
2	CHECK POOR CONTACT IN CONNECTORS.	Is there poor contact in connector between ABSCM&H/U and G sensor?	Repair connector.	Go to step 3.
3	CHECK ABSCM&H/U. 1) Connect all connectors. 2) Erase the memory. 3) Perform inspection mode. 4) Read out the trouble code.	Is the same trouble code as in the current diagnosis still being output?	Replace ABSCM&H/U. <Ref. to ABS-7 ABS Control Module and Hydraulic Control Unit (ABSCM&H/U).>	Go to step 4.
4	CHECK ANY OTHER TROUBLE CODES APPEARANCE.	Are other trouble codes being output?	Proceed with the diagnosis corresponding to the trouble code.	A temporary poor contact.
5	CHECK FREEZE FRAME DATA. 1) Select "Freeze frame data" on the select monitor. 2) Read front right wheel speed on the select monitor display.	Is the front right wheel speed on monitor display 0 km?	Go to step 6.	Go to step 16.
6	CHECK FREEZE FRAME DATA. Read front left wheel speed on the select monitor display.	Is the front left wheel speed on monitor display 0 km?	Go to step 7.	Go to step 16.
7	CHECK FREEZE FRAME DATA. Read rear right wheel speed on the select monitor display.	Is the rear right wheel speed on monitor display 0 km?	Go to step 8.	Go to step 16.
8	CHECK FREEZE FRAME DATA. Read rear left wheel speed on the select monitor display.	Is the rear left wheel speed on monitor display 0 km?	Go to step 9.	Go to step 16.
9	CHECK FREEZE FRAME DATA. Read G sensor output on the select monitor display.	Is the G sensor output on monitor display more than 3.65 V?	Go to step 10.	Go to step 16.
10	CHECK OPEN CIRCUIT IN G SENSOR OUTPUT HARNESS AND GROUND HARNESS. 1) Turn ignition switch to OFF. 2) Disconnect connector from ABSCM&H/U. 3) Measure resistance between ABSCM&H/U connector terminals. Connector & terminal (F49) No. 6 — No. 28:	Is the resistance between 4.3 and 4.9 k Ω ?	Go to step 11.	Repair harness/connector between G sensor and ABSCM&H/U.
11	CHECK BATTERY SHORT OF HARNESS. 1) Turn ignition switch to OFF. 2) Remove console box. 3) Disconnect connector from G sensor. 4) Disconnect connector from ABSCM&H/U. 5) Measure voltage between ABSCM&H/U connector and chassis ground. Connector & terminal (F49) No. 6 (+) — Chassis ground (-):	Is the voltage less than 1 V?	Go to step 12.	Repair harness between G sensor and ABSCM&H/U.

DIAGNOSTICS CHART WITH SUBARU SELECT MONITOR

ABS (DIAGNOSTICS)

No.	Step	Check	Yes	No
12	CHECK BATTERY SHORT OF HARNESS. 1) Turn ignition switch to ON. 2) Measure voltage between ABSCM&H/U connector and chassis ground. Connector & terminal (F49) No. 6 (+) — Chassis ground (-):	Is the voltage less than 1 V?	Go to step 13.	Repair harness between G sensor and ABSCM&H/U.
13	CHECK POOR CONTACT IN CONNECTORS.	Is there poor contact in connector between ABSCM&H/U and G sensor?	Repair connector.	Go to step 14.
14	CHECK ABSCM&H/U. 1) Connect all connectors. 2) Erase the memory. 3) Perform inspection mode. 4) Read out the trouble code.	Is the same trouble code as in the current diagnosis still being output?	Replace ABSCM&H/U. <Ref. to ABS-7 ABS Control Module and Hydraulic Control Unit (ABSCM&H/U).>	Go to step 15.
15	CHECK ANY OTHER TROUBLE CODES APPEARANCE.	Are other trouble codes being output?	Proceed with the diagnosis corresponding to the trouble code.	A temporary poor contact.
16	CHECK INPUT VOLTAGE OF G SENSOR. 1) Turn ignition switch to OFF. 2) Remove console box. 3) Disconnect G sensor from body. (Do not disconnect connector.) 4) Turn ignition switch to ON. 5) Measure voltage between G sensor connector terminals. Connector & terminal (R70) No. 1 (+) — No. 3 (-):	Is the voltage between 4.75 and 5.25 V?	Go to step 17.	Repair harness/connector between G sensor and ABSCM&H/U.
17	CHECK OPEN CIRCUIT IN G SENSOR OUTPUT HARNESS AND GROUND HARNESS. 1) Turn ignition switch to OFF. 2) Disconnect connector from ABSCM&H/U. 3) Measure resistance between ABSCM&H/U connector terminals. Connector & terminal (F49) No. 6 — No. 28:	Is the resistance between 4.3 and 4.9 k Ω ?	Go to step 18.	Repair harness/connector between G sensor and ABSCM&H/U.
18	CHECK G SENSOR. 1) Connect connector to G sensor. 2) Connect connector to ABSCM&H/U. 3) Turn ignition switch to ON. 4) Measure voltage between G sensor connector terminals. Connector & terminal (R70) No. 2 (+) — No. 3 (-):	Is the voltage between 2.1 and 2.5 V when G sensor is horizontal?	Go to step 19.	Replace G sensor. <Ref. to ABS-24 G Sensor.>
19	CHECK G SENSOR. Measure voltage between G sensor connector terminals. Connector & terminal (R70) No. 2 (+) — No. 3 (-):	Is the voltage between 3.7 and 4.1 V when G sensor is inclined forwards to 90°?	Go to step 20.	Replace G sensor. <Ref. to ABS-24 G Sensor.>
20	CHECK G SENSOR. Measure voltage between G sensor connector terminals. Connector & terminal (R70) No. 2 (+) — No. 3 (-):	Is the voltage between 0.5 and 0.9 V when G sensor is inclined backwards to 90°?	Go to step 21.	Replace G sensor. <Ref. to ABS-24 G Sensor.>

DIAGNOSTICS CHART WITH SUBARU SELECT MONITOR

ABS (DIAGNOSTICS)

No.	Step	Check	Yes	No
21	CHECK POOR CONTACT IN CONNECTORS. Turn ignition switch to OFF.	Is there poor contact in connector between ABSCM&H/U and G sensor?	Repair connector.	Go to step 22.
22	CHECK ABSCM&H/U. 1) Connect all connectors. 2) Erase the memory. 3) Perform inspection mode. 4) Read out the trouble code.	Is the same trouble code as in the current diagnosis still being output?	Replace ABSCM&H/U. <Ref. to ABS-7 ABS Control Module and Hydraulic Control Unit (ABSCM&H/U).>	Go to step 23.
23	CHECK ANY OTHER TROUBLE CODES APPEARANCE.	Are other trouble codes being output?	Proceed with the diagnosis corresponding to the trouble code.	A temporary poor contact.

DIAGNOSTICS CHART WITH SUBARU SELECT MONITOR

ABS (DIAGNOSTICS)

AG: TROUBLE CODE 56

— ABNORMAL G SENSOR HIGH μ OUTPUT — S006583E87

DIAGNOSIS:

- Faulty G sensor output voltage

TROUBLE SYMPTOM:

- ABS does not operate.

WIRING DIAGRAM:

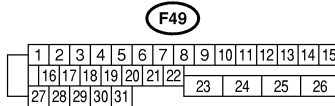
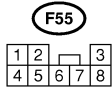
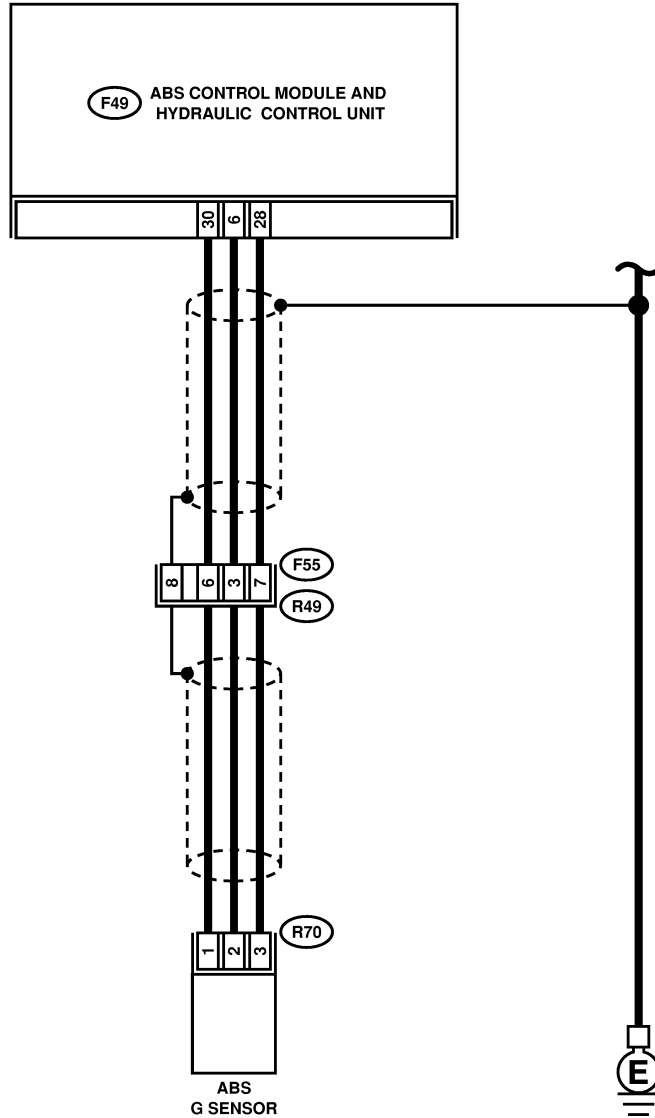

B4M1462

ABS-156

DIAGNOSTICS CHART WITH SUBARU SELECT MONITOR

ABS (DIAGNOSTICS)

No.	Step	Check	Yes	No
1	CHECK OUTPUT OF G SENSOR USING SELECT MONITOR. 1) Select "Current data display & Save" on the select monitor. 2) Read G sensor output on the select monitor display.	Is the G sensor output on monitor display 2.3 ± 0.2 V when the G sensor is in horizontal position?	Go to step 2.	Go to step 6.
2	CHECK POOR CONTACT IN CONNECTORS. Turn ignition switch to OFF.	Is there poor contact in connector between ABSCM&H/U and G sensor?	Repair connector.	Go to step 3.
3	CHECK ABSCM&H/U. 1) Connect all connectors. 2) Erase the memory. 3) Perform inspection mode. 4) Read out the trouble code.	Is the same trouble code as in the current diagnosis still being output?	Replace ABSCM&H/U. <Ref. to ABS-7 ABS Control Module and Hydraulic Control Unit (ABSCM&H/U).>	Go to step 4.
4	CHECK ANY OTHER TROUBLE CODES APPEARANCE.	Are other trouble codes being output?	Proceed with the diagnosis corresponding to the trouble code.	A temporary poor contact.
5	CHECK OPEN CIRCUIT IN G SENSOR OUTPUT HARNESS AND GROUND HARNESS. 1) Turn ignition switch to OFF. 2) Disconnect connector from ABSCM&H/U. 3) Measure resistance between ABSCM&H/U connector terminals. <i>Connector & terminal</i> <i>(F49) No. 6 — No. 28:</i>	Is the resistance between 4.3 and 4.9 k Ω ?	Go to step 6.	Repair harness/connector between G sensor and ABSCM&H/U.
6	CHECK GROUND SHORT OF HARNESS. Measure resistance between ABSCM&H/U connector and chassis ground. <i>Connector & terminal</i> <i>(F49) No. 28 — Chassis ground:</i>	Is the resistance more than 1 M Ω ?	Go to step 7.	Repair harness between G sensor and ABSCM&H/U. Replace ABSCM&H/U. <Ref. to ABS-7 ABS Control Module and Hydraulic Control Unit (ABSCM&H/U).>
7	CHECK G SENSOR. 1) Remove console box. 2) Remove G sensor from vehicle. 3) Connect connector to G sensor. 4) Connect connector to ABSCM&H/U. 5) Turn ignition switch to ON. 6) Measure voltage between G sensor connector terminals. <i>Connector & terminal</i> <i>(R70) No. 2 (+) — No. 3 (-):</i>	Is the voltage between 2.1 and 2.5 V when G sensor is horizontal?	Go to step 8.	Replace G sensor. <Ref. to ABS-24 G Sensor.>
8	CHECK G SENSOR. Measure voltage between G sensor connector terminals. <i>Connector & terminal</i> <i>(R70) No. 2 (+) — No. 3 (-):</i>	Is the voltage between 3.7 and 4.1 V when G sensor is inclined forwards to 90°?	Go to step 9.	Replace G sensor. <Ref. to ABS-24 G Sensor.>
9	CHECK G SENSOR. Measure voltage between G sensor connector terminals. <i>Connector & terminal</i> <i>(R70) No. 2 (+) — No. 3 (-):</i>	Is the voltage between 0.5 and 0.9 V when G sensor is inclined backwards to 90°?	Go to step 10.	Replace G sensor. <Ref. to ABS-24 G Sensor.>

DIAGNOSTICS CHART WITH SUBARU SELECT MONITOR

ABS (DIAGNOSTICS)

No.	Step	Check	Yes	No
10	CHECK ABSCM&H/U. 1) Turn ignition switch to OFF. 2) Connect all connectors. 3) Erase the memory. 4) Perform inspection mode. 5) Read out the trouble code.	Is the same trouble code as in the current diagnosis still being output?	Replace ABSCM&H/U. <Ref. to ABS-7 ABS Control Module and Hydraulic Control Unit (ABSCM&H/U).>	Go to step 11.
11	CHECK ANY OTHER TROUBLE CODES APPEARANCE.	Are other trouble codes being output?	Proceed with the diagnosis corresponding to the trouble code.	A temporary poor contact.

DIAGNOSTICS CHART WITH SUBARU SELECT MONITOR

ABS (DIAGNOSTICS)

MEMO:

ABS-159

DIAGNOSTICS CHART WITH SUBARU SELECT MONITOR

ABS (DIAGNOSTICS)

AH: TROUBLE CODE 56

— DETECTION OF G SENSOR STICK — S006583E88

DIAGNOSIS:

- Faulty G sensor output voltage

TROUBLE SYMPTOM:

- ABS does not operate.

WIRING DIAGRAM:

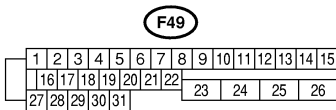
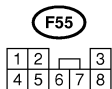
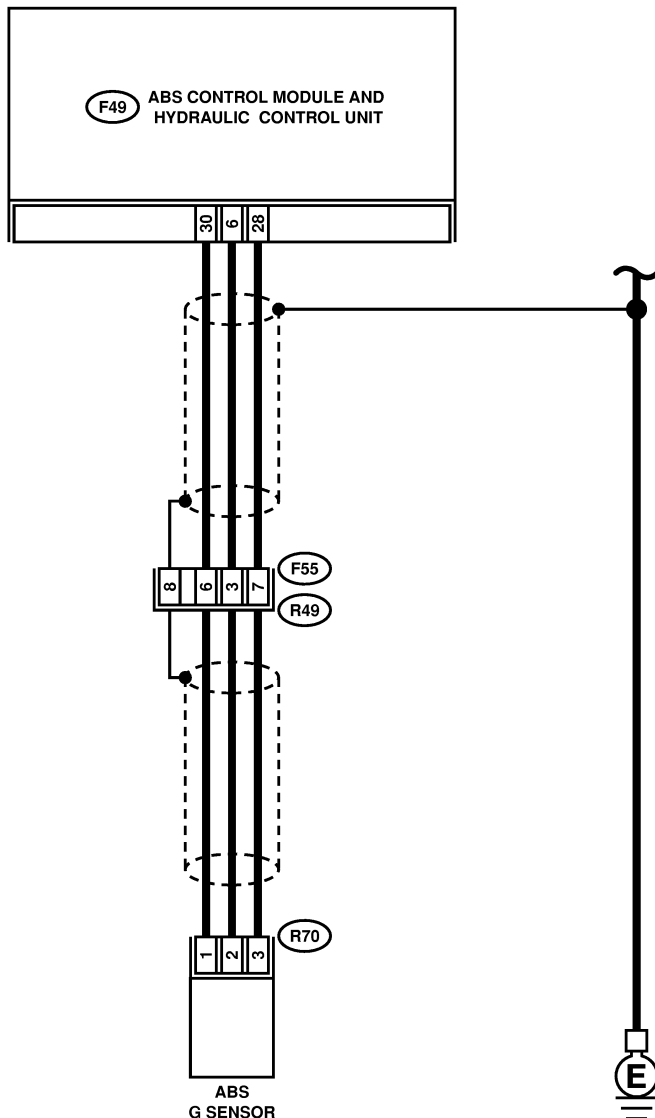

B4M1462

DIAGNOSTICS CHART WITH SUBARU SELECT MONITOR

ABS (DIAGNOSTICS)

No.	Step	Check	Yes	No
1	CHECK ALL FOUR WHEELS FOR FREE TURNING.	Have the wheels been turned freely such as when the vehicle is lifted up, or operated on a rolling road?	The ABS is normal. Erase the trouble code.	Go to step 2.
2	CHECK OUTPUT OF G SENSOR USING SELECT MONITOR. 1) Select "Current data display & Save" on the select monitor. 2) Read the select monitor display.	Is the G sensor output on the monitor display between 2.1 and 2.5 V when the vehicle is in horizontal position?	Go to step 3.	Go to step 8.
3	CHECK OUTPUT OF G SENSOR USING SELECT MONITOR. 1) Turn ignition switch to OFF. 2) Remove console box. 3) Remove G sensor from vehicle. (Do not disconnect connector.) 4) Turn ignition switch to ON. 5) Select "Current data display & Save" on the select monitor. 6) Read the select monitor display.	Is the G sensor output on the monitor display between 3.7 and 4.1 V when G sensor is inclined forwards to 90°?	Go to step 4.	Replace G sensor. <Ref. to ABS-24 G Sensor.>
4	CHECK OUTPUT OF G SENSOR USING SELECT MONITOR. Read the select monitor display.	Is the G sensor output on the monitor display between 0.5 and 0.9 V when G sensor is inclined backwards to 90°?	Go to step 5.	Replace G sensor. <Ref. to ABS-24 G Sensor.>
5	CHECK POOR CONTACT IN CONNECTORS. Turn ignition switch to OFF.	Is there poor contact in connector between ABSCM&H/U and G sensor?	Repair connector.	Go to step 6.
6	CHECK ABSCM&H/U. 1) Connect all connectors. 2) Erase the memory. 3) Perform inspection mode. 4) Read out the trouble code.	Is the same trouble code as in the current diagnosis still being output?	Replace ABSCM&H/U. <Ref. to ABS-7 ABS Control Module and Hydraulic Control Unit (ABSCM&H/U).>	Go to step 7.
7	CHECK ANY OTHER TROUBLE CODES APPEARANCE.	Are other trouble codes being output?	Proceed with the diagnosis corresponding to the trouble code.	A temporary poor contact.
8	CHECK OPEN CIRCUIT IN G SENSOR OUTPUT HARNESS AND GROUND HARNESS. 1) Turn ignition switch to OFF. 2) Disconnect connector from ABSCM&H/U. 3) Measure resistance between ABSCM&H/U connector terminals. Connector & terminal (F49) No. 6 — No. 28:	Is the resistance between 4.3 and 4.9 kΩ?	Go to step 9.	Repair harness/connector between G sensor and ABSCM&H/U.
9	CHECK G SENSOR. 1) Remove console box. 2) Remove G sensor from vehicle. 3) Connect connector to G sensor. 4) Connect connector to ABSCM&H/U. 5) Turn ignition switch to ON. 6) Measure voltage between G sensor connector terminals. Connector & terminal (R70) No. 2 (+) — No. 3 (-):	Is the voltage between 2.1 and 2.5 V when G sensor is horizontal?	Go to step 10.	Replace G sensor. <Ref. to ABS-24 G Sensor.>

DIAGNOSTICS CHART WITH SUBARU SELECT MONITOR

ABS (DIAGNOSTICS)

No.	Step	Check	Yes	No
10	CHECK G SENSOR. Measure voltage between G sensor connector terminals. <i>Connector & terminal</i> <i>(R70) No. 2 (+) — No. 3 (-):</i>	Is the voltage between 3.7 and 4.1 V when G sensor is inclined forwards to 90°?	Go to step 11.	Replace G sensor. <Ref. to ABS-24 G Sensor.>
11	CHECK G SENSOR. Measure voltage between G sensor connector terminals. <i>Connector & terminal</i> <i>(R70) No. 2 (+) — No. 3 (-):</i>	Is the voltage between 0.5 and 0.9 V when G sensor is inclined backwards to 90°?	Go to step 12.	Replace G sensor. <Ref. to ABS-24 G Sensor.>
12	CHECK ABSCM&H/U. 1) Turn ignition switch to OFF. 2) Connect all connectors. 3) Erase the memory. 4) Perform inspection mode. 5) Read out the trouble code.	Is the same trouble code as in the current diagnosis still being output?	Replace ABSCM&H/U. <Ref. to ABS-7 ABS Control Module and Hydraulic Control Unit (ABSCM&H/U).>	Go to step 13.
13	CHECK ANY OTHER TROUBLE CODES APPEARANCE.	Are other trouble codes being output?	Proceed with the diagnosis corresponding to the trouble code.	A temporary poor contact.