

5. Rear ABS Sensor S401185

A: REMOVAL S401185A18

- 1) Disconnect battery ground cable.
- 2) Lift-up the vehicle.
- 3) Remove fuel tank cover.

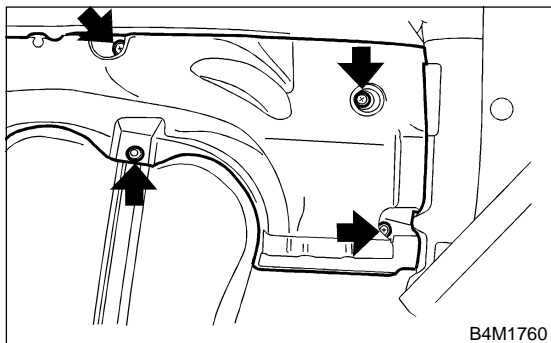

- 4) Disconnect rear ABS sensor connector.

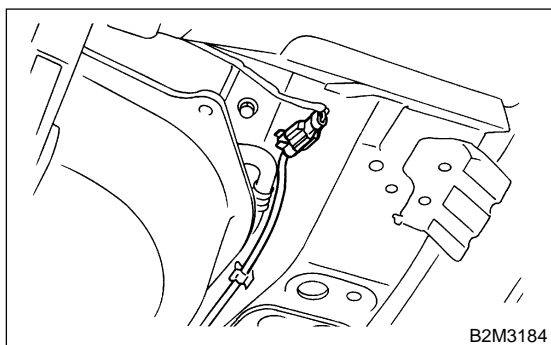

- 5) Remove rear sensor harness from clip on body side.

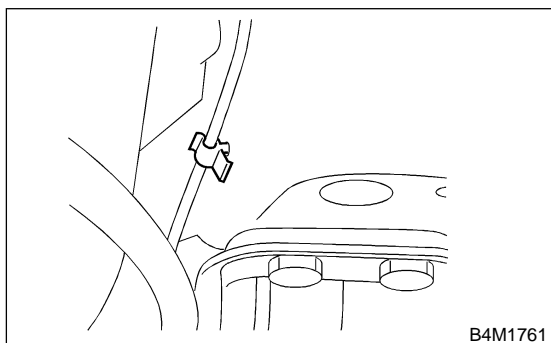

- 6) Remove bolts which hold rear sensor harness brackets.

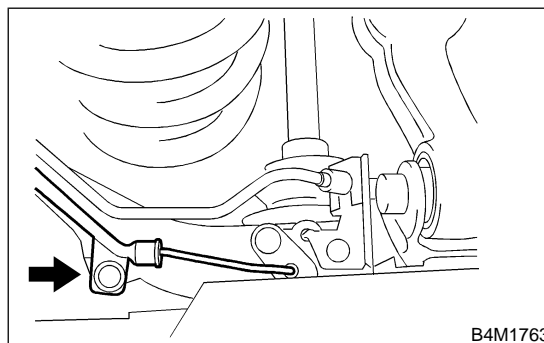
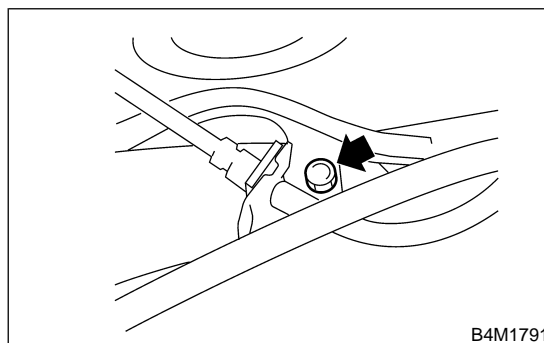
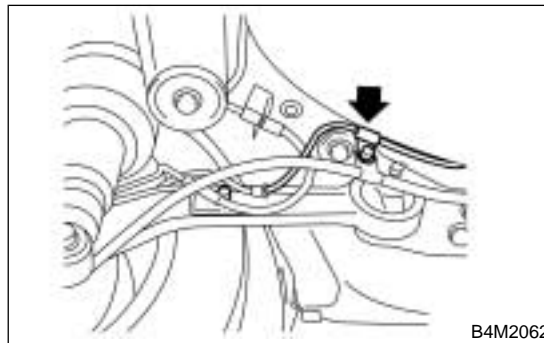

- 7) Remove rear ABS sensor from rear arm.
With disc brake model:

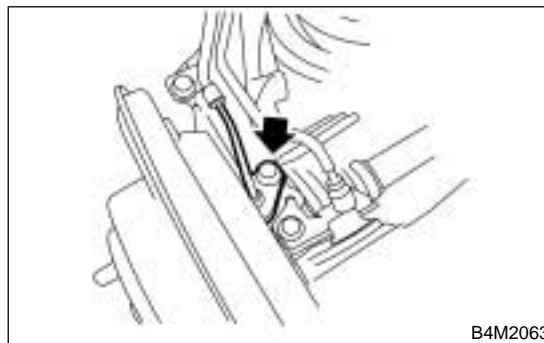

REAR ABS SENSOR

ABS

With drum brake model:

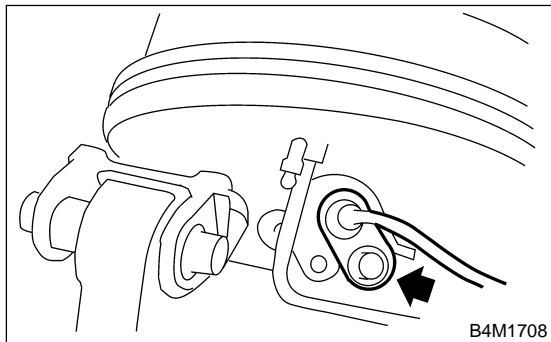

8) When inspecting rear tone wheel, remove rear drive shaft as rear tone wheel is unitized with BJ assembly of rear drive shaft.
<Ref. to DS-33 Rear Drive Shaft.>

CAUTION:

- Be careful not to damage pole piece located at tip of the sensor and teeth faces during removal.
- Do not pull sensor harness during removal.

B: INSTALLATION S401185A11

- 1) Install rear drive shaft to the vehicle.
<Ref. to DS-33 Rear Drive Shaft.>
- 2) Temporarily install rear ABS sensor on rear arm.

CAUTION:

Be careful not to strike ABS sensor's pole piece and tone wheel's teeth against adjacent metal parts during installation.

With disc brake model:



With drum brake model:

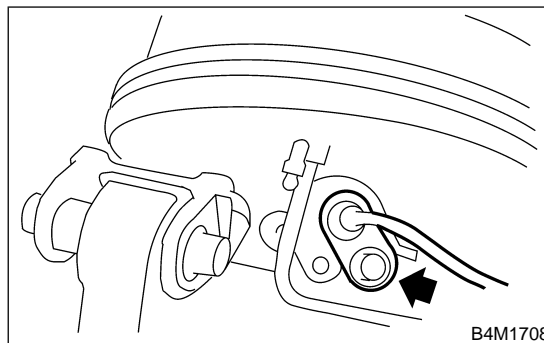

3) Install rear sensor harness brackets in the original positions and install harness on the clip.

Tightening torque:

32 N·m (3.3 kgf·m, 24 ft·lb)

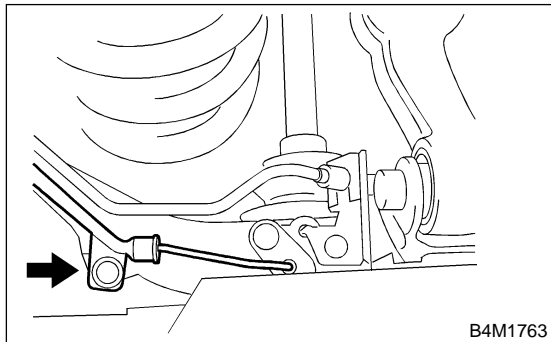

B4M1763

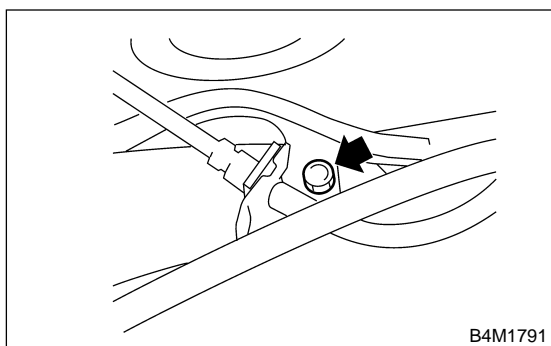

B4M1791

Tightening torque:

32 N·m (3.3 kgf·m, 24 ft·lb)

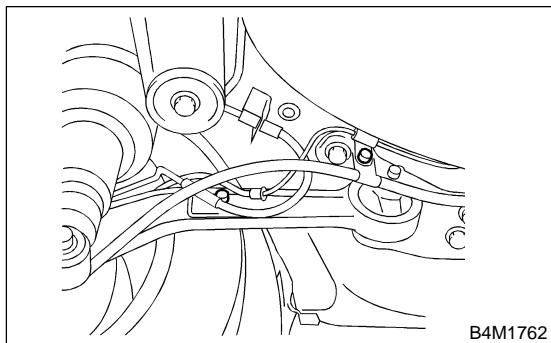

B4M1762

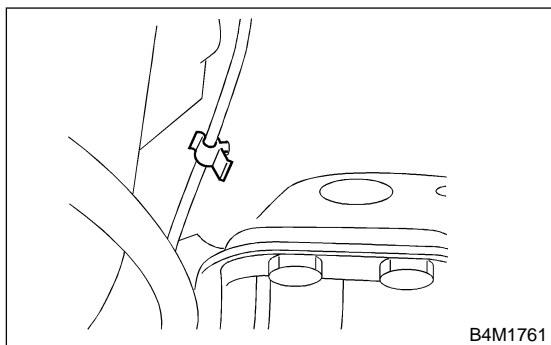

B4M1761

4) Place a thickness gauge between ABS sensor's and tone wheel's tooth face. After standard clearance is obtained over the entire perimeter, tighten ABS sensor on rear arm to specified torque.

ABS sensor standard clearance:

0.44 — 0.94 mm (0.0173 — 0.0370 in)

Tightening torque:

32 N·m (3.3 kgf·m, 24 ft·lb)

CAUTION:

Check the marks on the harness to make sure that no distortion exists. (RH: white, LH: yellow)

NOTE:

If the clearance is outside specifications, readjust.

5) After confirmation of the ABS sensor clearance, connect connector to ABS sensor and install fuel tank cover.

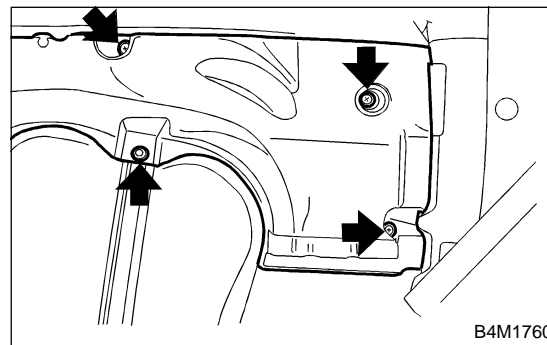

B4M1760

6) Connect connector to battery ground cable.

REAR ABS SENSOR

ABS

C: INSPECTION S401185A10

1. ABS SENSOR S401185A1001

- 1) Check pole piece of ABS sensor for foreign particles or damage. If necessary, clean pole piece or replace ABS sensor.
- 2) Measure ABS sensor resistance.

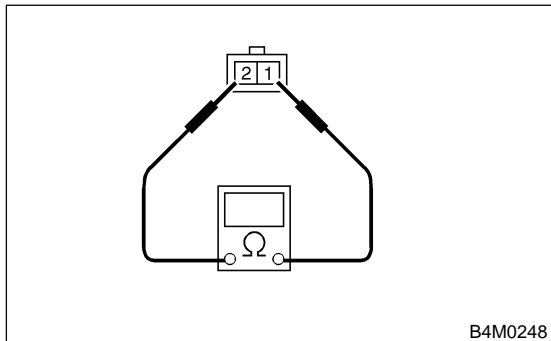

Terminal No.	Standard
1 and 2	1.25±0.25 kΩ

CAUTION:

If resistance is outside the standard value, replace ABS sensor with new one.

NOTE:

Check ABS sensor cable for discontinuity. If necessary, replace with a new one.

2. SENSOR GAP S401185A1002

- 1) Measure the distance "A" between ABS sensor surface and sensor pole face.

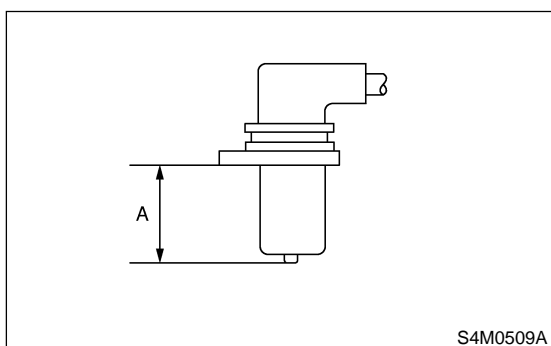

- 2) Measure the distance "B" between surface where the front axle housing meets the ABS sensor, and the tone wheel.

NOTE:

Measure so that the gauge touches the tone wheel teeth top.

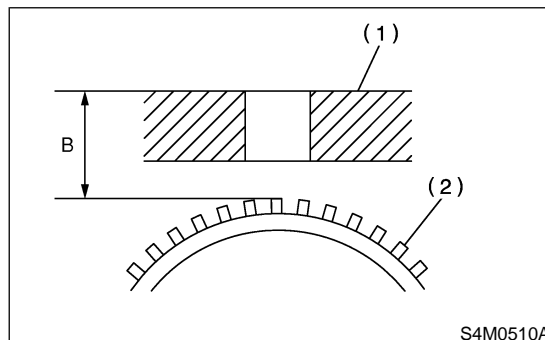

- (1) Axle housing
- (2) Tone wheel

- 3) Find the gap between the ABS sensor pole face and the surface of the tone wheel teeth by putting the measured values in the formula below and calculating.

$$\text{ABS sensor clearance} = B - A$$

ABS sensor standard clearance:

0.44 — 0.94 mm (0.0173 — 0.0370 in)

NOTE:

If the clearance is outside specifications, readjust.

3. OUTPUT VOLTAGE S401185A1003

Output voltage can be checked by the following method. Install resistor and condenser, then rotate wheel about 2.75 km/h (2 MPH) or equivalent.

NOTE:

Regarding terminal No., please refer to item 1. ABS SENSOR.

D: ADJUSTMENT S401185A01

Adjust the gap using spacer (Part No. 26755AA000).

