

FRONT BRAKE PAD

Brake

2. Front Brake Pad S405178

A: REMOVAL S405178A18

- 1) Remove lock pin.
- 2) Raise caliper body.
- 3) Remove pad.

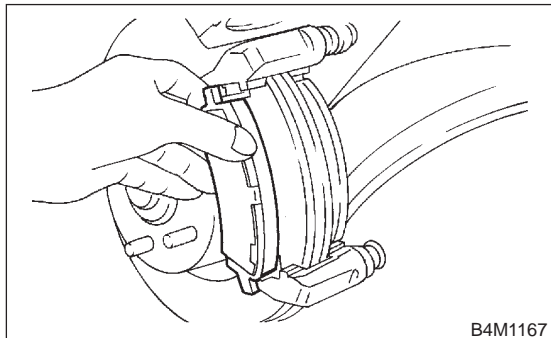

NOTE:

If brake pad is difficult to remove, proceed as follows:

- (1) Remove caliper body and fasten it provisionally to coil spring.
- (2) Remove support.
- (3) Place a support in a vise between wooden blocks.

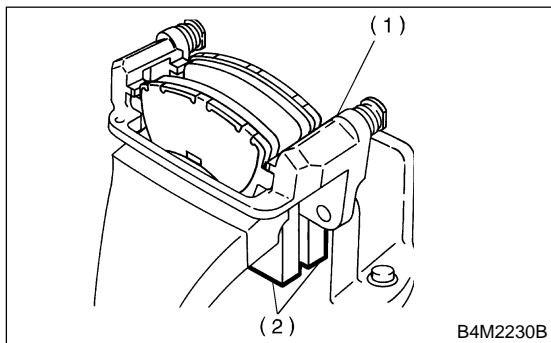

- (1) Support
- (2) Wooden blocks

(4) Attach a rod of less than 12 mm (0.47 in) dia. to the shaded area of brake pad, and strike the rod with a hammer to drive brake pad out of place.

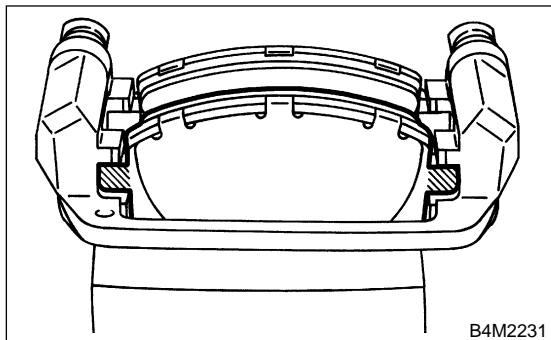

B: INSTALLATION S405178A11

- 1) Apply thin coat of Molykote AS880N (Part No. 26298AC000) to the frictional portion between pad and pad clip.
- 2) Apply thin coat of Molykote AS880N (Part No. 26298AC000) to the frictional portion between pad and pad inner shim.

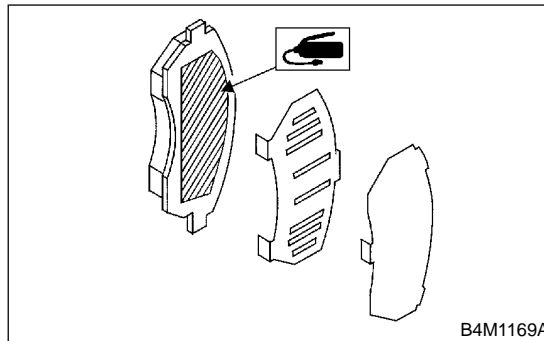

- 3) Install pads on support.
- 4) Install caliper body on support.

Tightening torque:

39 N·m (4.0 kgf·m, 28.9 ft·lb)

NOTE:

If it is difficult to push piston during pad replacement, loosen air bleeder to facilitate work.

C: INSPECTION S405178A10

Check pad thickness A.

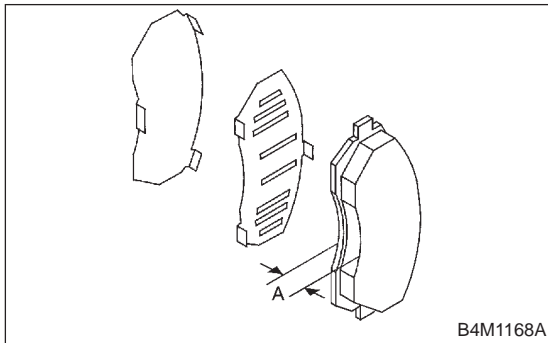

Pad thickness (including back metal)	Standard value	17 mm (0.67 in)
	Wear limit	7.5 mm (0.295 in)

CAUTION:

- Always replace the pads for both the left and right wheels at the same time. Also replace pad clips if they are twisted or worn.
- A wear indicator is provided on the inner disc brake pad. If the pad wears down to such an extent that the end of the wear indicator contacts the disc rotor, a squeaking sound is produced as the wheel rotates. If this sound is heard, replace the pad.
- Replace pad if there is oil or grease on it.