

# STOP LIGHT SWITCH

Brake

## 18. Stop Light Switch S405542

### A: REMOVAL S405542A18

- 1) Disconnect ground terminal from battery.
- 2) Disconnect stop light switch connector.
- 3) Loosen nuts, and unscrew stop light switch to remove.

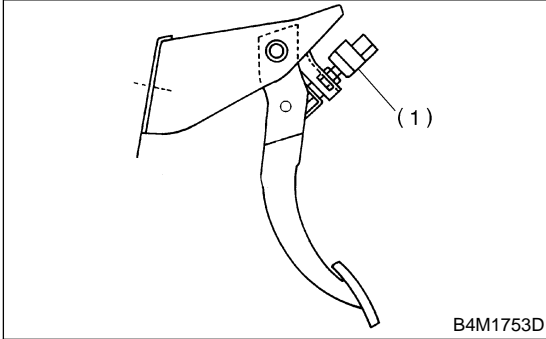

(1) Stop light switch

### B: INSTALLATION S405542A11

- 1) Screw the stop light switch onto a bracket and secure it temporarily with a nut.
- 2) Adjust stop light switch position, and then tighten the nut.

<Ref. to BR-65 ADJUSTMENT, Stop Light Switch.>

**Tightening torque:**  
**8 N·m (0.8 kgf-m, 5.8 ft-lb)**

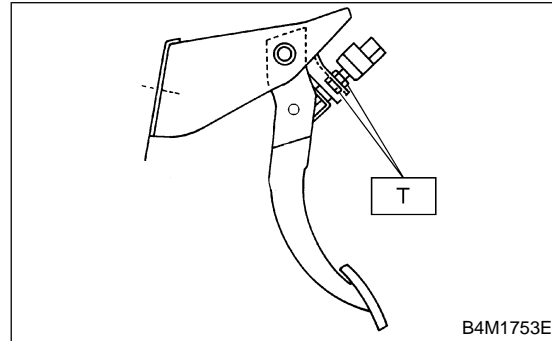

## C: INSPECTION S405542A10

1) If stop light switch does not operate properly (or if it does not stop at the specified position), replace with a new one.

**Specified position: L**  
 $2^{+1.5}/_0 \text{ mm } (0.079^{+0.059}/_0 \text{ in})$

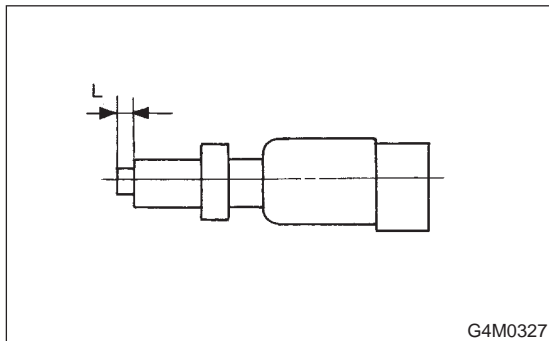

2) Measure the clearance between threaded end of stop light switch and stopper.

**CAUTION:**  
 Be careful not to rotate stop light switch.

**Stop light switch clearance: A**  
 $0.3 \text{ mm } (0.012 \text{ in})$

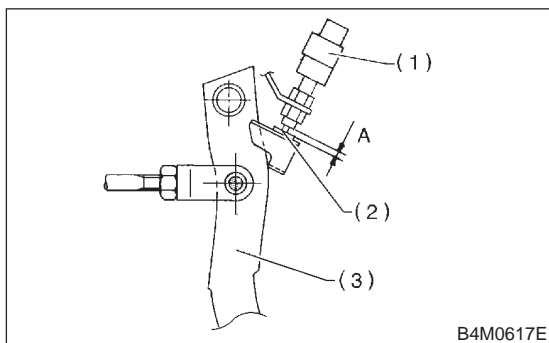

- (1) Stop light switch
- (2) Stopper
- (3) Brake pedal

3) If it is not in specified value, adjust it by adjusting position of stop light switch.

**CAUTION:**  
 Be careful not to rotate stop light switch.

## D: ADJUSTMENT S405542A01

Loosen the lock nut, and adjust stop light switch position until the clearance between threaded end of the stop light switch and the stopper becomes 0.3 mm (0.012 in). Then, tighten the lock nut.

