

5. VDC Sequence Control S402195

A: OPERATION S402195A16

- 1) Under the VDC sequence control, after the hydraulic unit solenoid valve is driven, the operation of the hydraulic unit can be checked by means of the brake tester or pressure gauge.
- 2) VDC sequence control can be started by diagnosis connector or select monitor.

1. VDC SEQUENCE CONTROL WITH DIAGNOSIS CONNECTOR S402195A1601

- 1) Connect diagnosis terminals to terminals No. 5 and No. 8 of the diagnosis connector beside driver's seat heater unit.

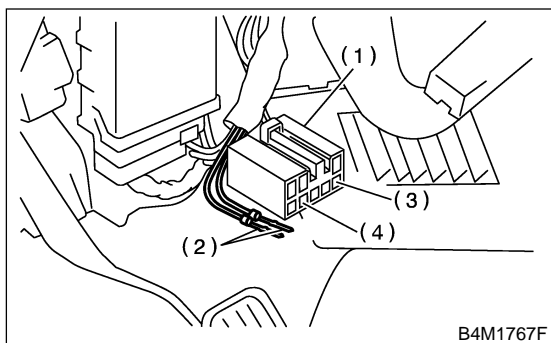

- (1) Diagnosis connector
- (2) Diagnosis terminal
- (3) 8 terminal
- (4) 5 terminal

- 2) Set the speed of all wheels at 2.75 km/h (2 MPH) or less.
- 3) Turn ignition switch OFF.
- 4) Turn ignition switch ON and start engine immediately, confirming that ABS and VDC warning light goes ON and then OFF. After ABS and VDC warning light goes OFF, within 0.5 seconds depress the brake pedal once, then within 3 second depress the brake pedal twice more and release it.

CAUTION:

Do not depress the clutch pedal.

NOTE:

- When the ignition switch is set to on, the brake pedal must not be depressed.
 - Engine must operate.
 - If the VDC sequence control does not start, do the procedure over again.
- 5) After completion of VDC sequence control, turn ignition switch OFF.

2. VDC SEQUENCE CONTROL WITH SELECT MONITOR S402195A1602

NOTE:

- In the event of any trouble, the sequence control may not be operative. In such a case, activate the sequence control, referring to "VDC SEQUENCE CONTROL WITH DIAGNOSIS CONNECTOR".

<Ref. to VDC-21 VDC SEQUENCE CONTROL WITH DIAGNOSIS CONNECTOR, OPERATION, VDC Sequence Control.>

- When the diagnosis terminal is connected to the diagnosis connector, the sequence control will not operate.

- 1) Connect select monitor to data link connector beside driver's seat instrument panel lower cover.
- 2) Turn ignition switch ON.
- 3) Turn select monitor switch ON.
- 4) Put select monitor to "BRAKE CONTROL" mode.
- 5) Select "VDC Check Mode" in {Function check sequence} menu to start 'VDC sequence control'.

CAUTION:

Do not depress the clutch pedal.

- 6) When the message "Press YES" is displayed, press 「YES」 key.
- 7) Operation points will be displayed on select monitor.

VDC SEQUENCE CONTROL

VDC

3. CONDITIONS FOR VDC SEQUENCE CONTROL S402195A1603

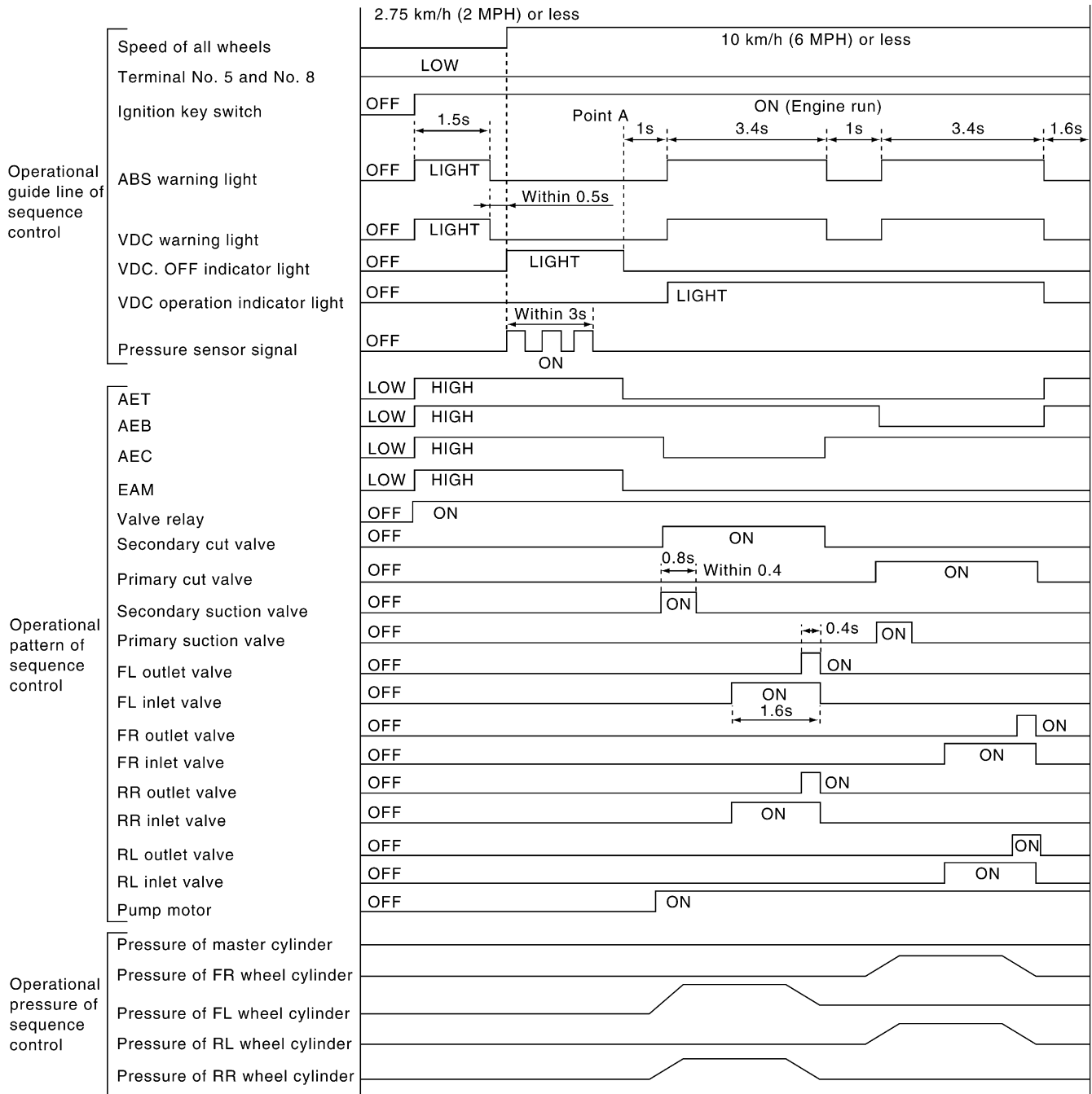

B4M1916A

NOTE:

- When select monitor is used, control operation starts at point A. The patterns from IGN key ON to the point A show that operation is started by diagnosis connector.
- HIGH means high voltage.
- LOW means low voltage.

B: SPECIFICATION S402195A22**1. CONDITIONS FOR COMPLETION OF VDC SEQUENCE CONTROL** S402195A2201

When the following conditions develop, the VDC sequence control stops and VDC operation is returned to the normal control mode.

- 1) When the speed of at least one wheel reaches 10 km/h (6 MPH).
- 2) When terminal No. 5 or No. 8 are separated from diagnosis terminals. (When select monitor is not used.)
- 3) When the brake pedal is released during sequence control and the braking lamp switch is set to off.
- 4) When brake pedal is depressed after ignition key is turned to ON, and before VDC warning light goes out. (When select monitor is not used.)
- 5) When brake pedal is not depressed after ignition key is turned to ON, and within 0.5 seconds after VDC warning light goes out. (When select monitor is not used.)
- 6) After completion of the sequence control.
- 7) When malfunction is detected. (When select monitor is used.)