

7. Steering Angle Sensor S402197

A: REMOVAL S402197A18

- 1) Disconnect battery ground cable.

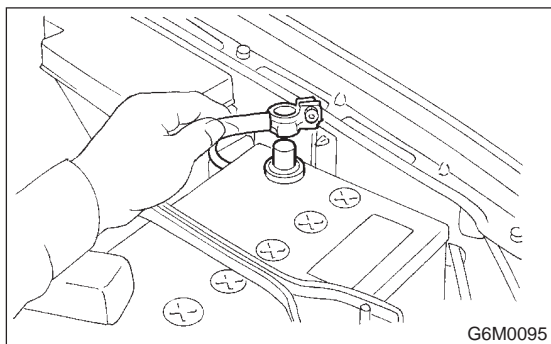

- 2) Remove airbag module.
<Ref. to AB-12 REMOVAL, Driver's Airbag Module.>

WARNING:

Always refer to "Airbag System" before performing airbag module service (if so equipped).
<Ref. to AB-3 CAUTION, General Description.>

- 3) Remove steering wheel nut, then draw out steering wheel from shaft using steering puller.

NOTE:

Steering wheel must be removed at the straight ahead position.

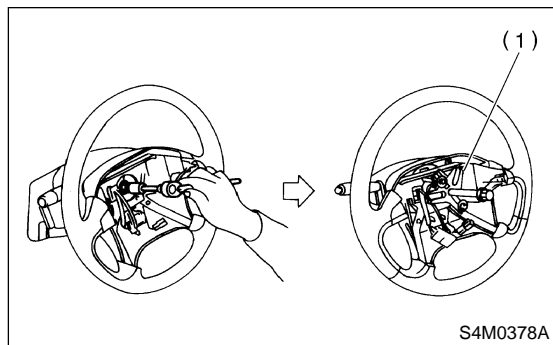

- (1) Steering puller

- 4) Remove the screw securing lower steering column cover.

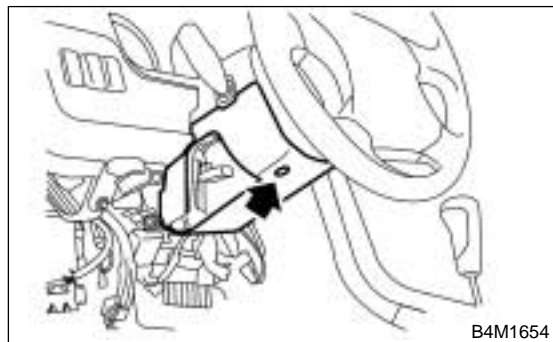

- 5) Remove two screws securing upper steering column cover.
- 6) Release the lock of harness band and disconnect connector of steering angle sensor.

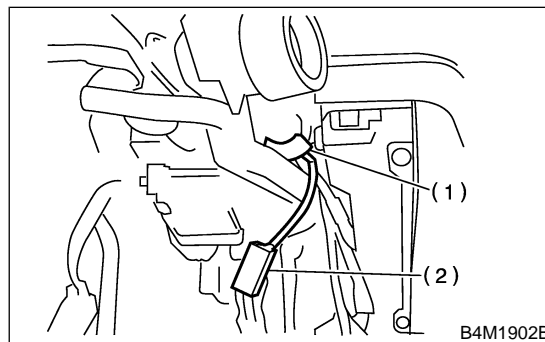

- (1) Harness connector
- (2) Connector

- 7) Remove bolts which hold roll connector and steering angle sensor onto steering column.

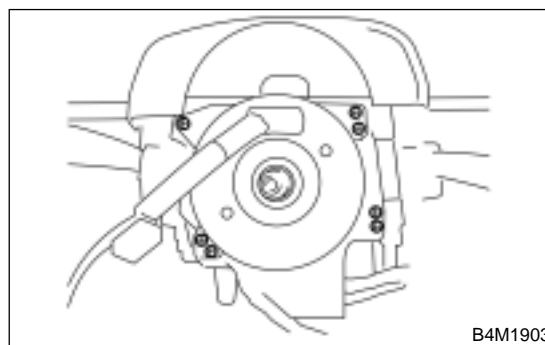

- 8) Remove roll connector and steering angle sensor.

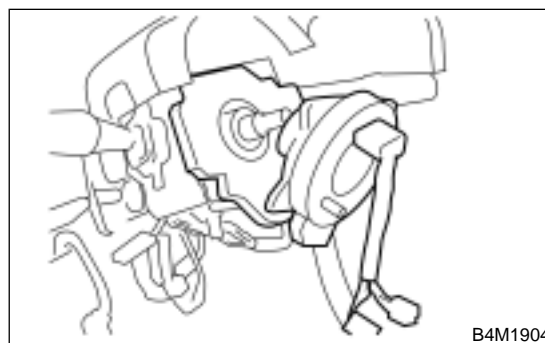

NOTE:

Do not turn steering angle sensor as it's center position has been recognized by VDCCM.

B: INSTALLATION S402197A11

CAUTION:

Ensure that front wheels are set in straight forward direction.

1) Place steering angle sensor on steering column, confirming that the sensor is positioned as in the figure.



2) Conduct centering of roll connector.
 <Ref. to AB-22 INSTALLATION, Roll Connector.>
 3) Place roll connector over steering angle sensor and tighten bolts which secure roll connector and steering angle sensor.

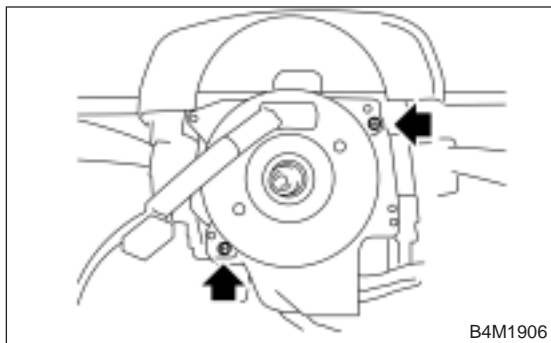

4) Tighten bolts which install roll connector and steering angle sensor onto steering column.

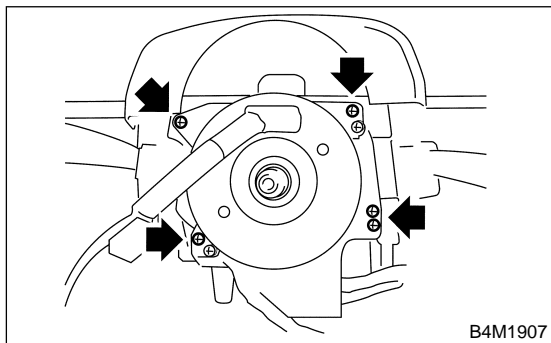

5) Set steering wheel to neutral and install it onto steering shaft.

Tightening torque:

44 N·m (4.5 kgf·m, 32.5 ft·lb)

Column cover-to-steering wheel clearance:

2 — 4 mm (0.08 — 0.16 in)

CAUTION:

Insert roll connector guide pin into guide hole on lower end of surface of steering wheel to prevent damage. Draw out airbag system connector, horn connector and cruise control connectors from guide hole of steering wheel lower end.

6) Install airbag module to steering wheel.
 <Ref. to AB-13 INSTALLATION, Driver's Airbag Module.>

WARNING:

Always refer to "Airbag System" before performing the service operation.
 <Ref. to AB-3 CAUTION, General Description.>

7) Connect battery ground cable.

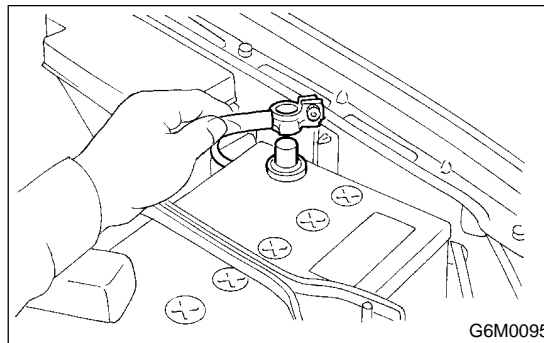

CAUTION:

After completion of installation procedure, the following two position settings must be made.

- Steering angle sensor center positioning
 - Yaw rate and lateral G sensor 0 positioning
- These procedures are necessary for VDCCM to later recognize what position the vehicle is in. For procedures for the above two settings, <Ref. to VDC-12 ADJUSTMENT, VDC Control Module (VDCCM).>

C: INSPECTION S402197A10

Refer to "VDC section" for inspection procedures of steering angle sensor.
<Ref. to VDC-110 TROUBLE CODE 71 ABNORMAL STEERING ANGLE SENSOR, Diagnostics Chart with Diagnosis Connector.>