

GENERAL DESCRIPTION

Drive Shaft System

1. General Description S301001

A: SPECIFICATIONS S301001E49

1. PROPELLER SHAFT S301001E4901

Propeller shaft type	DOJ type	
Front propeller shaft Joint-to-joint length: L_1 mm (in)	AT	629 (24.76)
	MT	688 (27.09)
Rear propeller shaft Joint-to-joint length: L_2 mm (in)	773 (30.43)	
Outside diameter of tube: mm (in)	D_1	63.5 (2.500)
	D_2	57.0 (2.244)

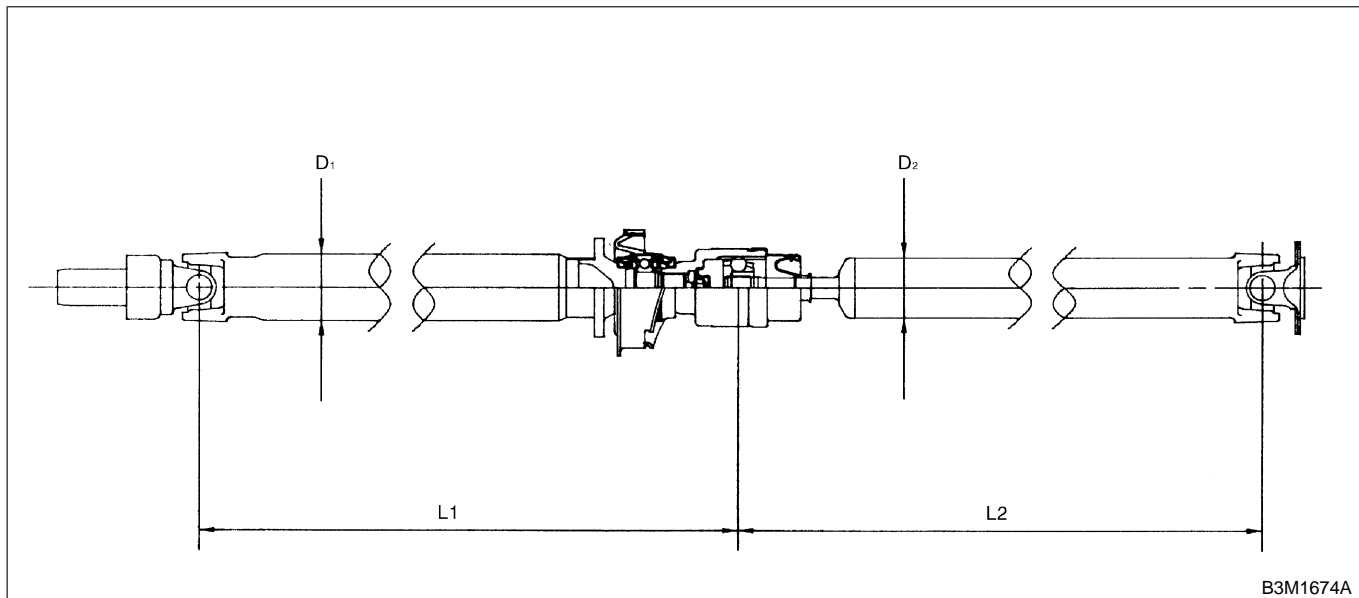

2. FRONT DRIVE SHAFT ASSEMBLY S301001E4902

Type of drive shaft assembly	SHAFT
	Shaft diameter
BJ87+SFJ82	26 mm (1.02 in)

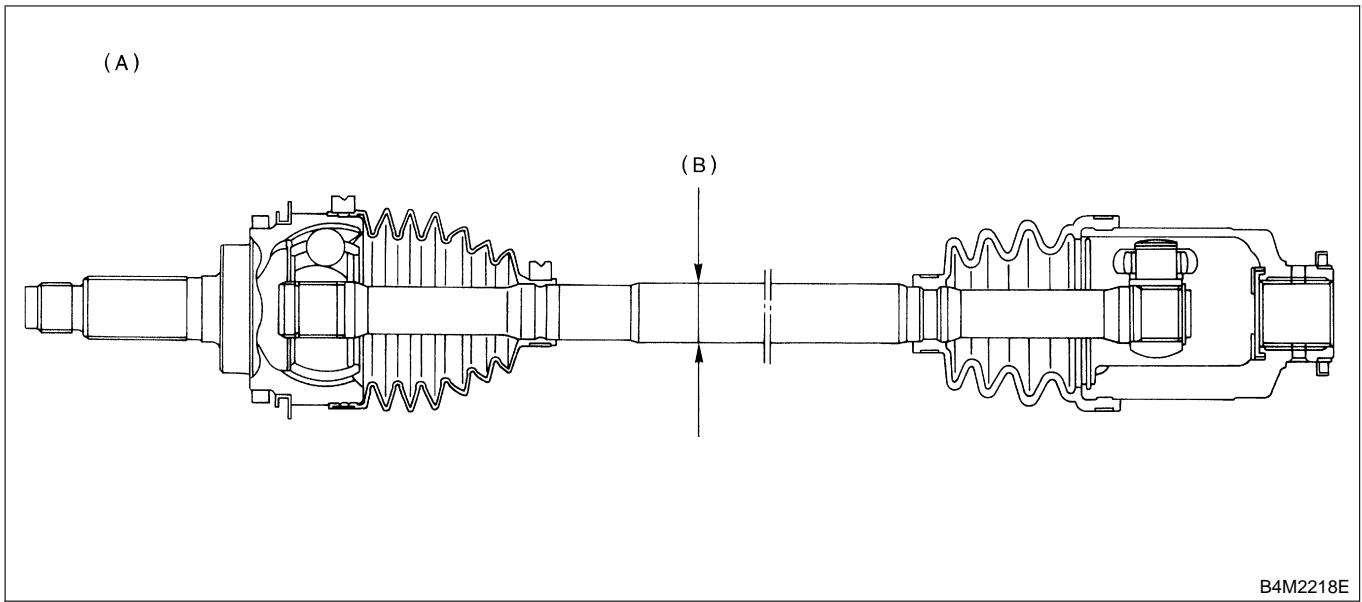

(A) BJ87+SFJ82

(B) Measuring point

GENERAL DESCRIPTION

Drive Shaft System

3. REAR DRIVE SHAFT ASSEMBLY S301001E4903

Type of axle shaft assembly	SHAFT
	No. of identification, protrusion on shaft
82AC-RH, 82AC-LH	2 (Two)
79AC-RH, 79AC-LH	1 (One)
79AC	None

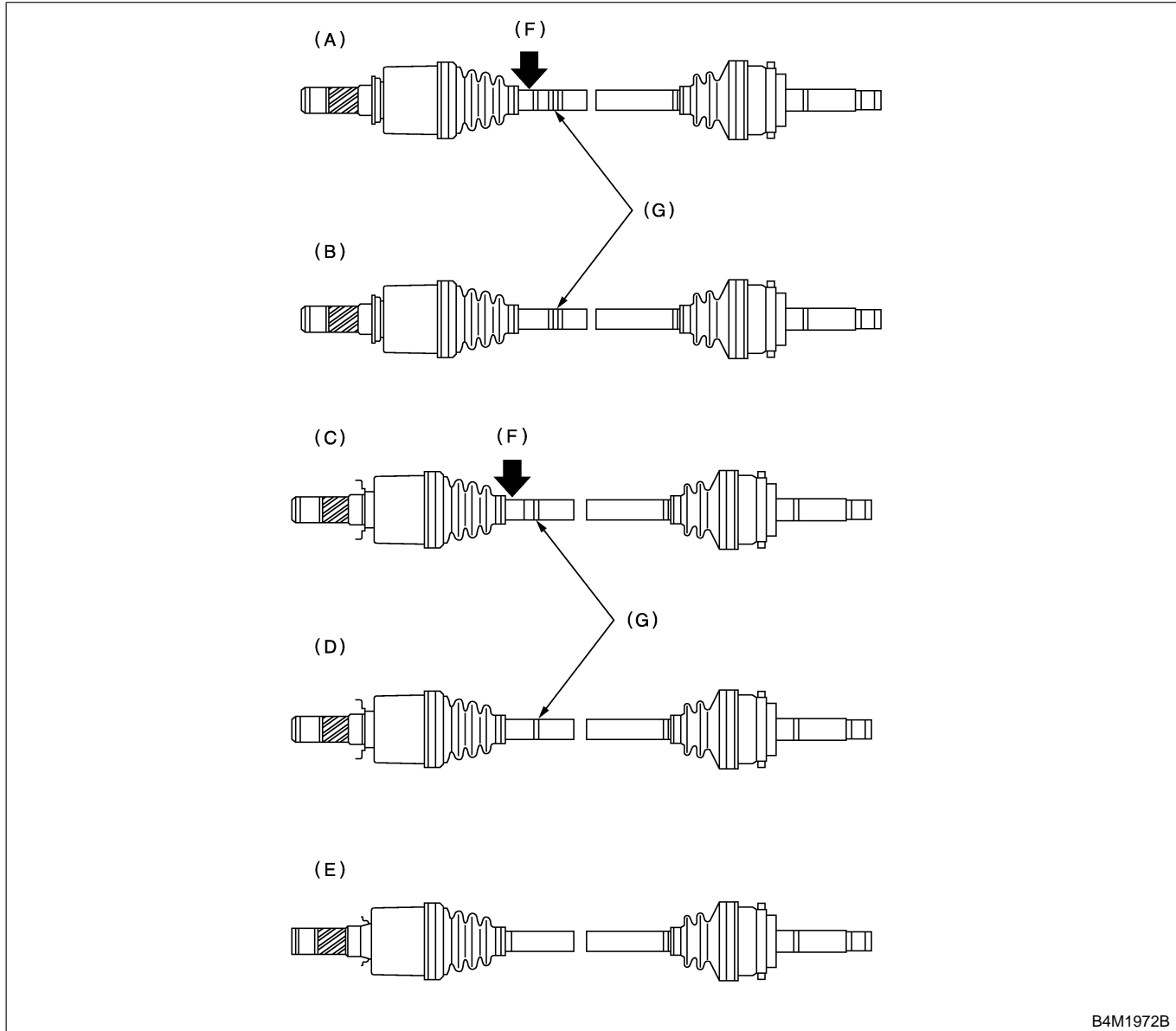

B4M1972B

- (A) 82AC-RH
- (B) 82AC-LH
- (C) 79AC-RH

- (D) 79AC-LH
- (E) 79AC
- (F) Indication mark of RH

- (G) Identification protrusion

B: COMPONENT S301001A05

1. PROPELLER SHAFT S301001A0501

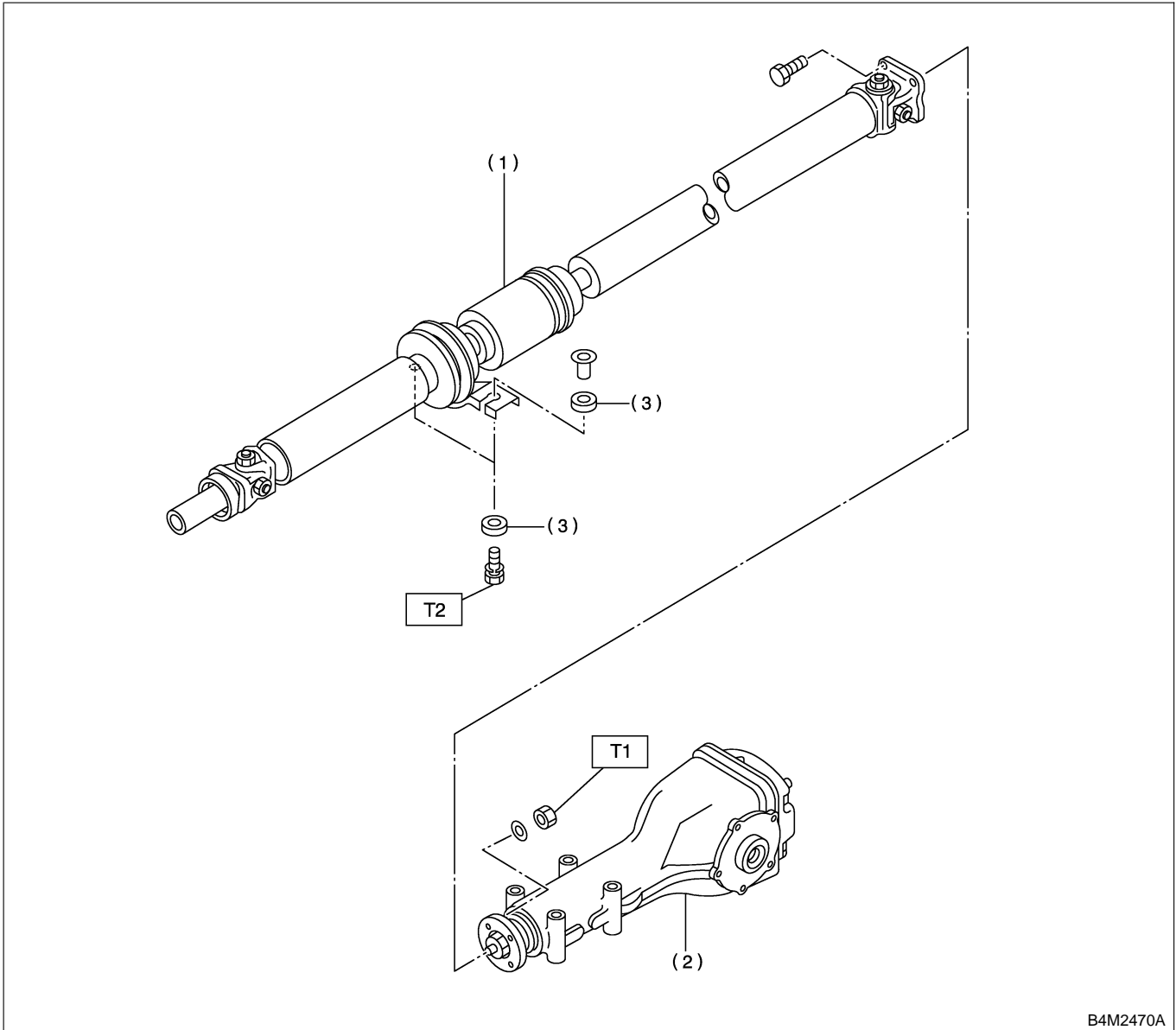

B4M2470A

- (1) Propeller shaft
- (2) Rear differential
- (3) Bush

Tightening torque: N-m (kgf-m, ft-lb)

T1: 31 (3.2, 23.1)

T2: 52 (5.3, 38.3)

GENERAL DESCRIPTION

Drive Shaft System

2. FRONT AXEL S301001A0502

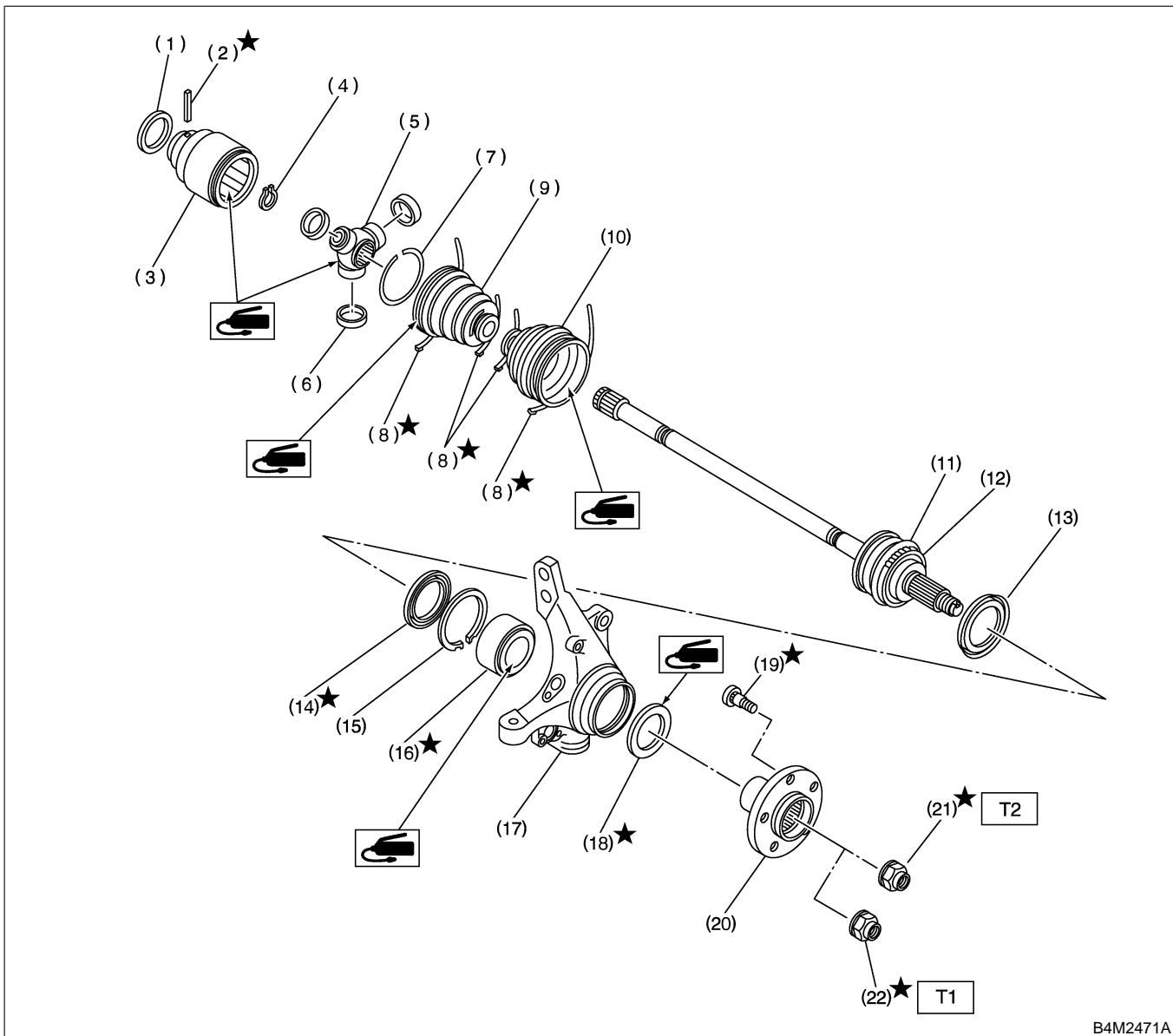

- (1) Baffle plate (SFJ)
- (2) Spring pin
- (3) Outer race (SFJ)
- (4) Snap ring
- (5) Trunnion
- (6) Free ring
- (7) Circlip
- (8) Boot band
- (9) Boot band
- (10) Boot (BJ)

- (11) BJ ASSY
- (12) Tone wheel
- (13) Baffle plate
- (14) Oil seal (IN)
- (15) Snap ring
- (16) Bearing
- (17) Housing
- (18) Oil seal (OUT)
- (19) Hub bolt
- (20) Hub

- (21) Axle nut (3.0 ℓ model: Olive color)
- (22) Axle nut (2.5 ℓ model: Gold color)

Tightening torque: N-m (kgf-m, ft-lb)

T1: 186 (19, 137)

T2: 216 (22, 159)

3. REAR AXLE S301001A0503

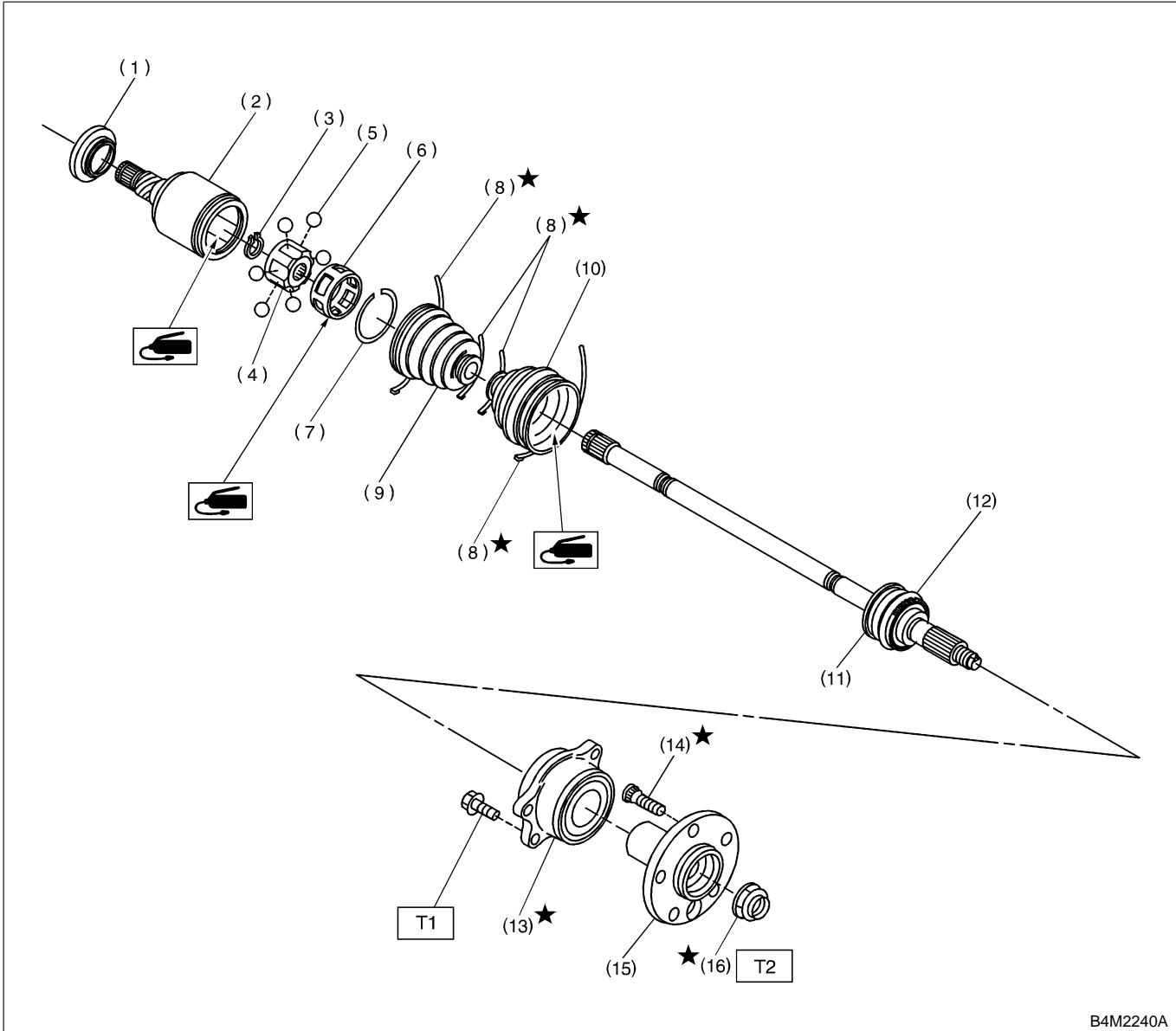

B4M2240A

- (1) Baffle plate (DOJ)
- (2) Outer race (DOJ)
- (3) Snap ring
- (4) Inner race
- (5) Ball
- (6) Cage
- (7) Circlip

- (8) Boot band
- (9) Boot (DOJ)
- (10) Boot (BJ)
- (11) BJ ASSY
- (12) Tone wheel
- (13) Hub unit bearing
- (14) Hub bolt

- (15) Hub
- (16) Axle nut (Olive color)

Tightening torque: N-m (kgf-m, ft-lb)

T1: 66 (6.7, 48.5)

T2: 235 (24, 174)

C: CAUTION S301001A03

- Wear working clothing, including a cap, protective goggles, and protective shoes during operation.
- Remove contamination including dirt and corrosion before removal, installation or disassembly.
- Keep the disassembled parts in order and protect them from dust or dirt.
- Before removal, installation or disassembly, be sure to clarify the failure. Avoid unnecessary removal, installation, disassembly, and replacement.
- Be careful not to burn your hands, because each part on the vehicle is hot after running.
- Use SUBARU genuine grease etc. or the equivalent. Do not mix grease etc. with that of another grade or from other manufacturers.
- Be sure to tighten fasteners including bolts and nuts to the specified torque.
- Place shop jacks or safety stands at the specified points.
- Apply grease onto sliding or revolution surfaces before installation.
- Before installing O-rings or snap rings, apply sufficient amount of grease to avoid damage and deformation.
- Before securing a part on a vice, place cushioning material such as wood blocks, aluminum plate, or shop cloth between the part and the vice.

D: PREPARATION TOOL S301001A17

1. SPECIAL TOOLS S301001A1701

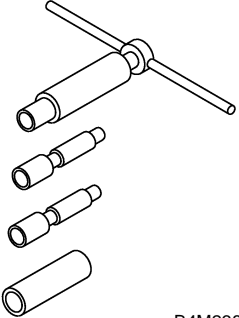
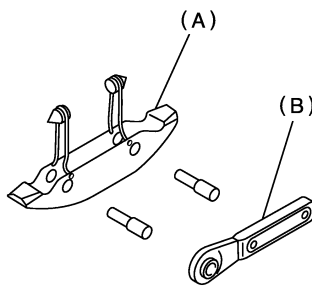
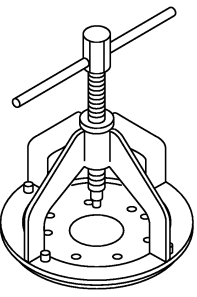
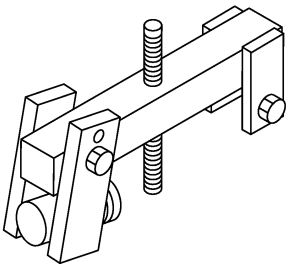
ILLUSTRATION	TOOL NUMBER	DESCRIPTION	REMARKS
 <p style="text-align: right; margin-right: 10px;">B4M2386</p>	922431000	AXLE SHAFT INSTALLER	<ul style="list-style-type: none"> ● Used for installing axle shaft into housing. ● Used with ADAPTER (927390000).
 <p style="text-align: right; margin-right: 10px;">B4M2387A</p>	925091000	BAND TIGHTENING TOOL	<ul style="list-style-type: none"> ● Used for tightening boot band. (A) Jig for band (B) Ratchet wrench
 <p style="text-align: right; margin-right: 10px;">B4M2388</p>	926470000	AXLE SHAFT PULLER	Used for removing axle shaft.
 <p style="text-align: right; margin-right: 10px;">B4M2389</p>	927060000	HUB REMOVER	<ul style="list-style-type: none"> ● Used for removing front hub. ● Used with HUB STAND (927080000).

GENERAL DESCRIPTION

Drive Shaft System

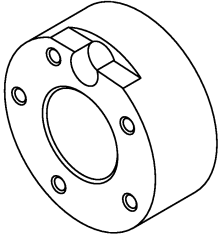
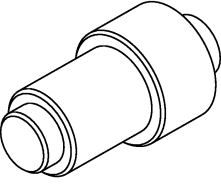
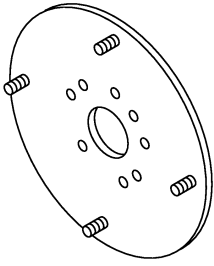
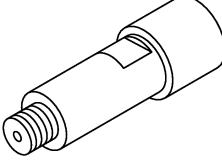
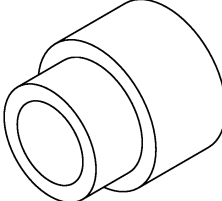
ILLUSTRATION	TOOL NUMBER	DESCRIPTION	REMARKS
 <p style="text-align: center;">B4M2390</p>	927080000	HUB STAND	Used for disassembling and assembling hub bolt in hub.
 <p style="text-align: center;">B4M2391</p>	927100000	BEARING PULLER	<ul style="list-style-type: none"> ● Used for disassembling and assembling front housing bearing. ● Used with HOUSING STAND (927400000).
 <p style="text-align: center;">B4M2392</p>	927140000	AXLE SHAFT PULLER PLATE	Same as plate 2 included in AXLE SHAFT PULLER (926470000).
 <p style="text-align: center;">B4M2393</p>	927390000	ADAPTER	Used as an adapter for AXLE SHAFT INSTALLER (922431000).
 <p style="text-align: center;">B4M2394</p>	927400000	HOUSING STAND	<ul style="list-style-type: none"> ● Used for disassembling and assembling front housing bearing. ● Used with BEARING PULLER (927100000).

DS-10

GENERAL DESCRIPTION

Drive Shaft System

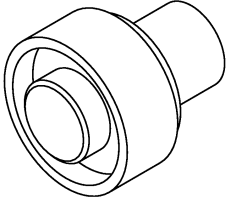
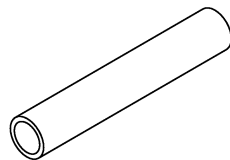
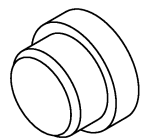
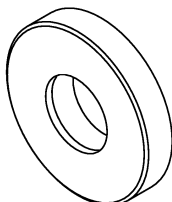
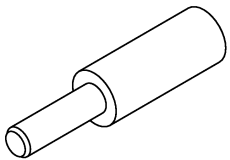
ILLUSTRATION	TOOL NUMBER	DESCRIPTION	REMARKS
 <p style="text-align: center;">B4M2395</p>	927410000	OIL SEAL INSTALLER	<ul style="list-style-type: none"> ● Used for installing oil seal into front housing. ● Used with HOUSING STAND (927400000).
 <p style="text-align: center;">B4M2396</p>	398507703	DUMMY COLLAR	Used for removing hub ASSY from hub unit.
 <p style="text-align: center;">B4M2397</p>	399520105	SEAT	Used for removing inner race from hub ASSY.
 <p style="text-align: center;">B4M2398</p>	28499AE000	BEARING SPACHER	Used for installing hub unit into hub ASSY.
 <p style="text-align: center;">B4M2399</p>	927120000	HUB INSTALLER	Used for installing hub.

GENERAL DESCRIPTION

Drive Shaft System

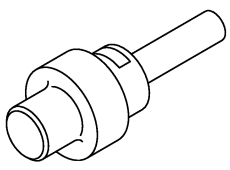
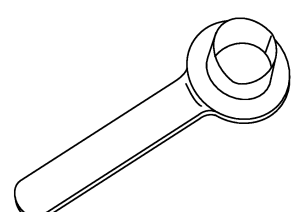
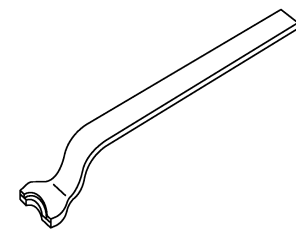
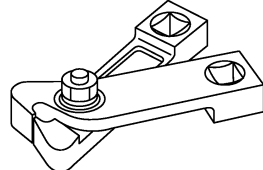
ILLUSTRATION	TOOL NUMBER	DESCRIPTION	REMARKS
 <p style="text-align: center;">B4M2400</p>	927450000	HUB INSTALLER	<ul style="list-style-type: none"> • Used for installing hub unit into hub ASSY. • Used with BEARING SPACER (28499AE000) and HUB STAND (927080000).
 <p style="text-align: center;">B4M2401</p>	28099PA090	OIL SEAL PROTECTOR	<ul style="list-style-type: none"> • Used for installing rear drive shaft into rear differential. • For protecting oil seal.
 <p style="text-align: center;">B4M2402</p>	28099PA100	DRIVE SHAFT REMOVER	Used for removing rear drive shaft from rear differential.
 <p style="text-align: center;">B4M2403</p>	28099AC000	BOOT BAND PLIERS	Used for tightening front BJ boot band.

2. GENERAL PURPOSE TOOLS S301001A1702

TOOL NAME	REMERKS
Puller	Used for removing ball joint from knuckle arm.
Dial gauge	Used for inspecting propeller shaft run-out.
Snap ring pliers	Used for installing and removing snap ring.