

2. Front Exhaust Pipe S102065

A: REMOVAL S102065A18

- 1) Disconnect battery ground cable.

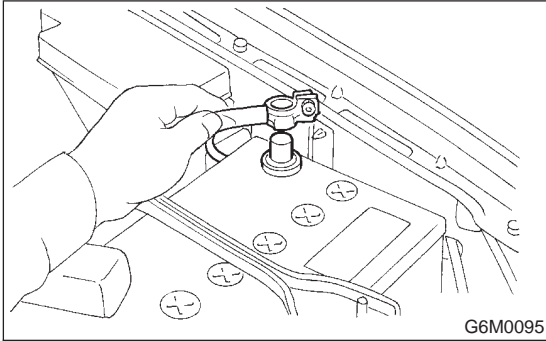

- 2) Disconnect front oxygen (A/F) sensor connector.

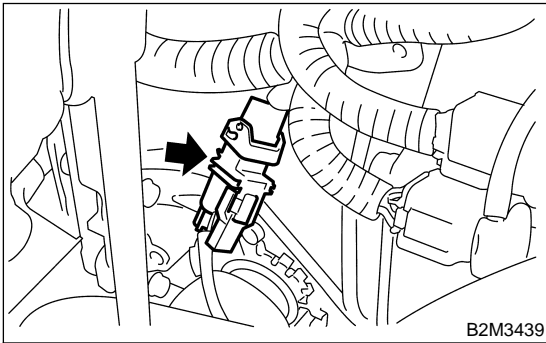

- 3) Lift-up the vehicle.
- 4) Disconnect rear oxygen sensor connector.

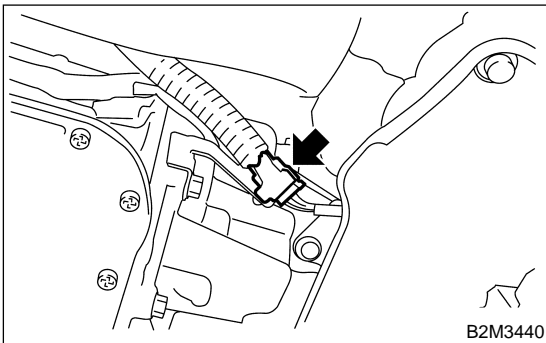

- 5) Separate front and center exhaust pipe assembly from rear exhaust pipe.

WARNING:
Be careful, exhaust pipe is hot.

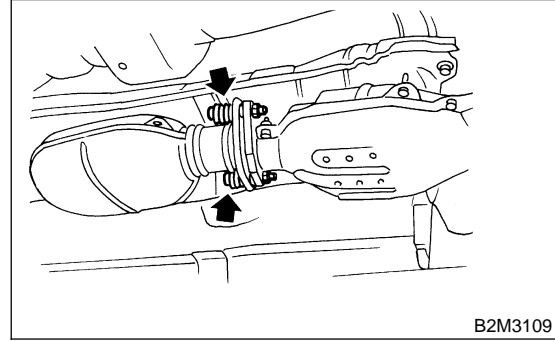

- 6) Remove under cover.

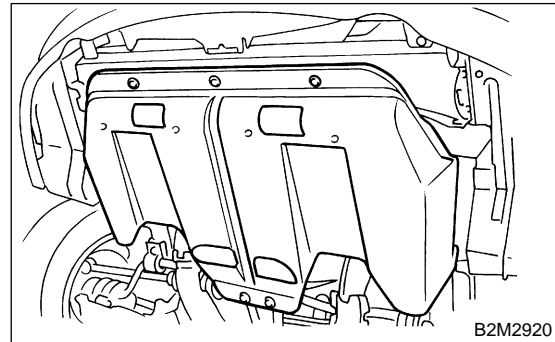

- 7) Remove bolts which hold front exhaust pipe onto cylinder heads.

CAUTION:
Be careful not to pull down front and center exhaust pipe assembly.

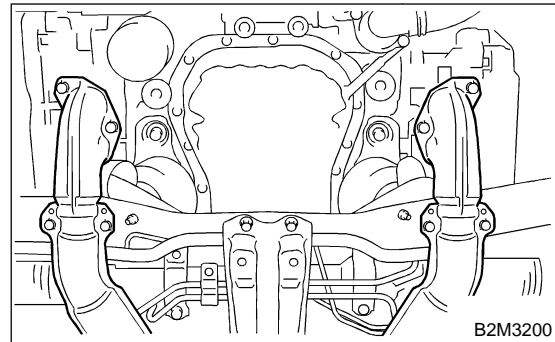

FRONT EXHAUST PIPE

Exhaust

8) Remove bolt which installs front and center exhaust pipe assembly to hanger bracket.

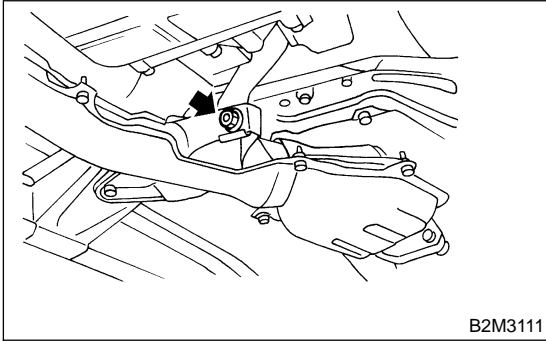

9) Remove front and center exhaust pipe assembly from the vehicle.

CAUTION:

- Be careful not to let front and center exhaust pipe assembly fall off when removing as it is quite heavy.
- After removing front and center exhaust assembly, do not apply excessive pulling force on rear exhaust pipe.

10) Separate front exhaust pipe from center exhaust pipe.

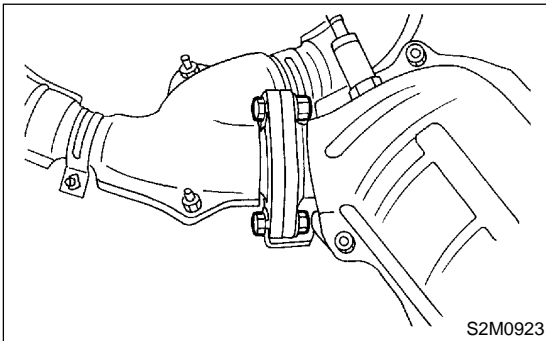

B: INSTALLATION S102065A11

1) Install front exhaust pipe to center exhaust pipe.

CAUTION:

Replace gaskets with new ones.

Tightening torque:

30 N·m (3.1 kgf-m, 22.4 ft-lb)

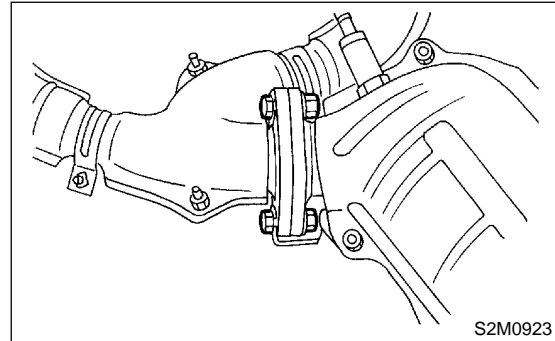

2) Install front and center exhaust pipe assembly to the vehicle.

3) Temporarily tighten bolt which installs front and center exhaust pipe assembly to hanger bracket.

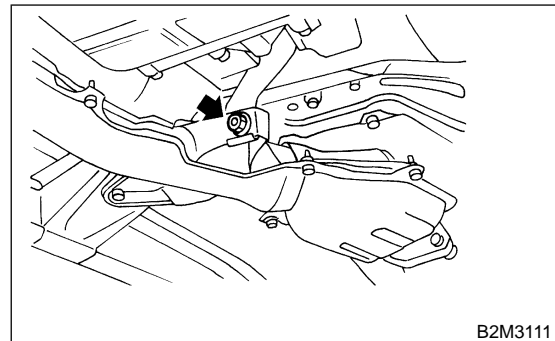

4) Tighten bolts which hold front exhaust pipe onto cylinder heads.

Tightening torque:

30 N·m (3.1 kgf-m, 22.4 ft-lb)

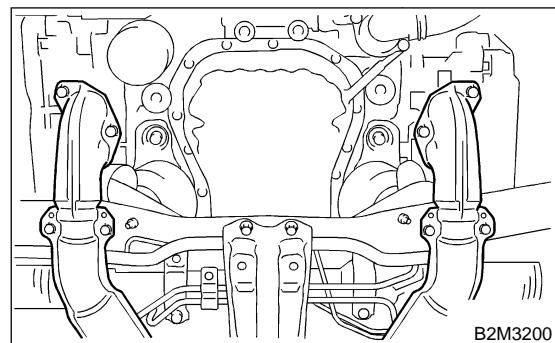

5) Install under cover.

6) Tighten bolts which install front and center exhaust pipe assembly to rear exhaust pipe.

Tightening torque:

18 N·m (1.8 kgf·m, 13.0 ft·lb)

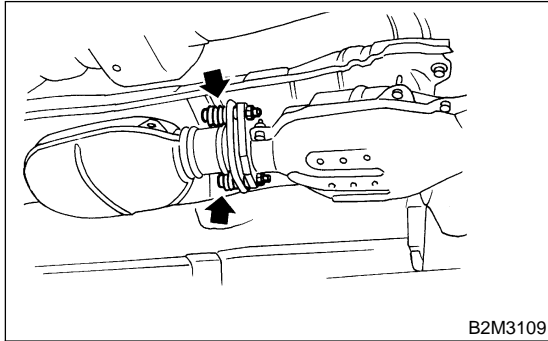

7) Tighten bolt which holds front and center exhaust pipe assembly to hanger bracket.

Tightening torque:

35 N·m (3.6 kgf·m, 26.0 ft·lb)

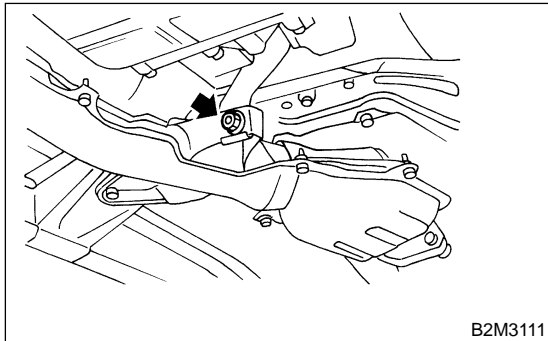

8) Connect rear oxygen sensor connector.

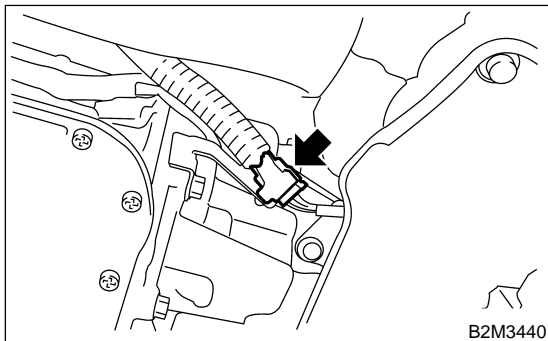

9) Lower the vehicle.

10) Connect front oxygen (A/F) sensor connector.

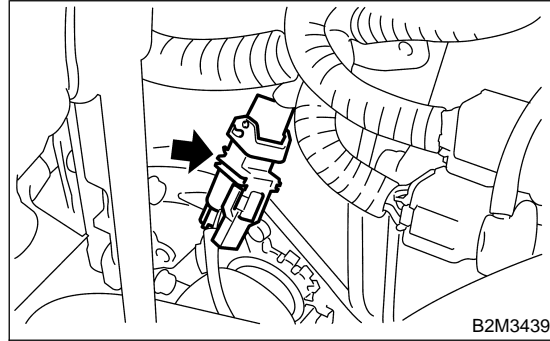

11) Connect battery ground cable.

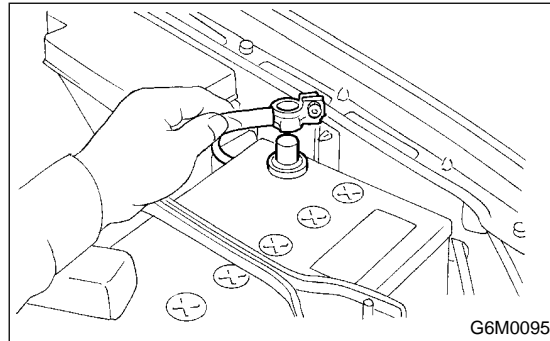

C: INSPECTION

S102065A10

- 1) Make sure there are no exhaust leaks from connections and welds.
- 2) Make sure there are no holes or rusting.