

FUEL PUMP

Fuel Injection (Fuel Systems)

24. Fuel Pump S105025

A: REMOVAL S105025A18

WARNING:

- Place "NO FIRE" signs near the working area.
- Be careful not to spill fuel on the floor.
- During work procedures, if fuel tank is more than 3/4 full, be careful because fuel may spill.

NOTE:

Fuel pump assembly consists of fuel pump and fuel level sensor.

- 1) Release fuel pressure. <Ref. to FU(H4)-70 RELEASING OF FUEL PRESSURE, OPERATION, Fuel.>
- 2) Open fuel filler flap lid and remove fuel filler cap.

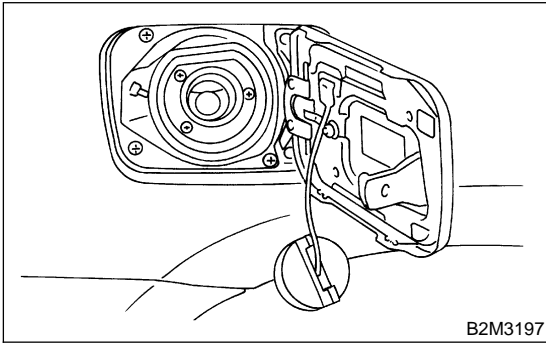

- 3) Disconnect battery ground cable.

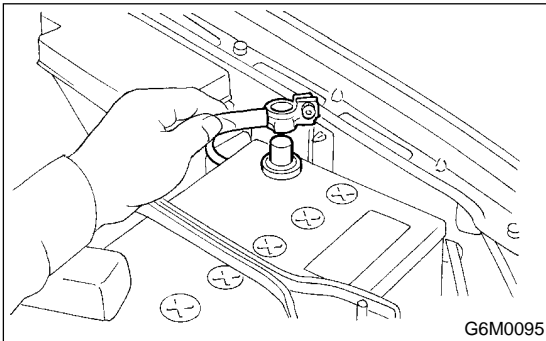

- 4) Lift-up the vehicle.
- 5) Remove front side fuel tank cover.

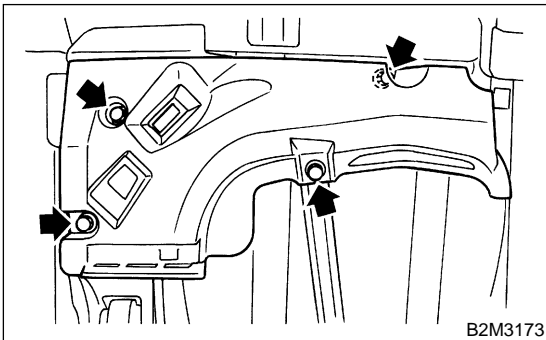

- 6) Drain fuel from fuel tank. Set a container under the vehicle and remove drain plug from fuel tank.

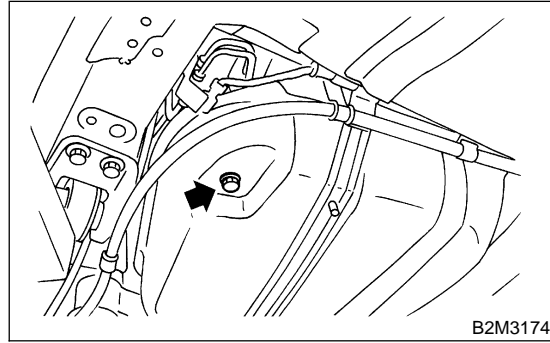

- 7) Tighten fuel drain plug and install front right side fuel tank cover.

Tightening torque:

26 N·m (2.65 kgf-m, 19.2 ft-lb)

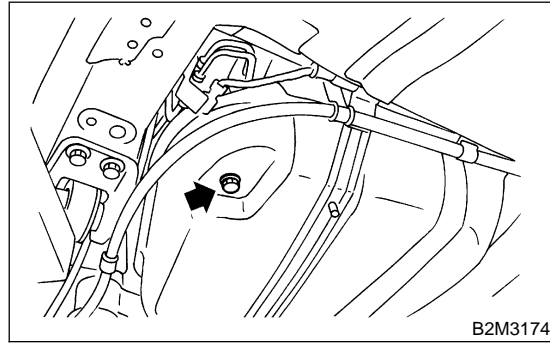

Tightening torque:

18 N·m (1.8 kgf-m, 13.0 ft-lb)

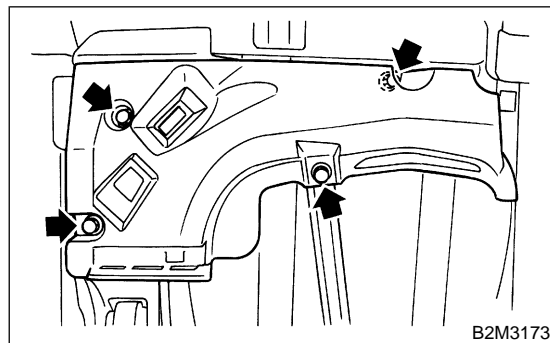

- 8) Raise rear seat and turn floor mat up.

FU(H4)-90

9) Remove access hole lid.

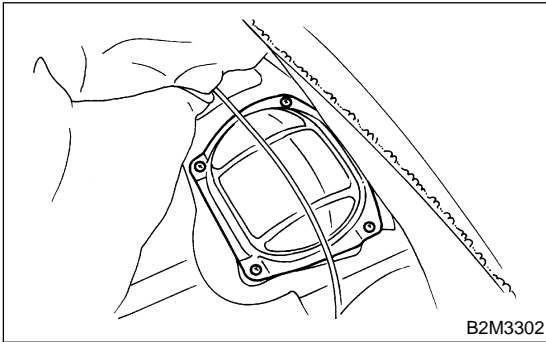

10) Disconnect connector from fuel pump.

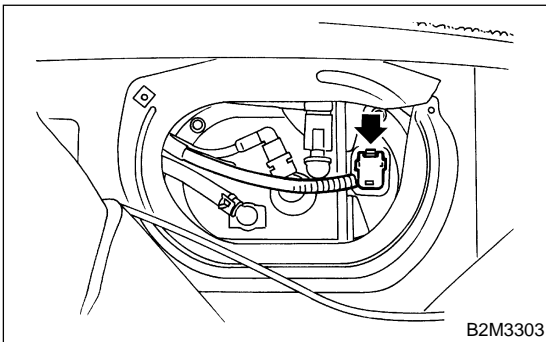

11) Move clips and then disconnect jet pump hose (C).

12) Disconnect quick connector and then disconnect fuel delivery hose (A) and return hose (B).
<Ref. to FU(H4)-98 REMOVAL, Fuel Delivery, Return and Evaporation Lines.>

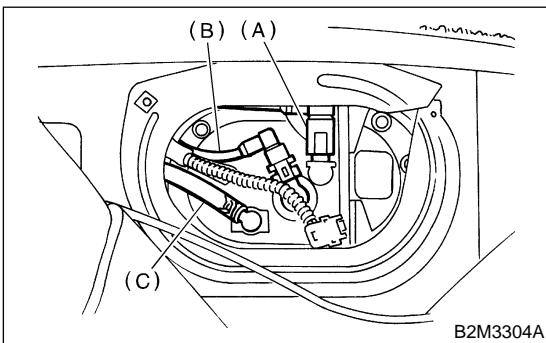

13) Remove nuts which install fuel pump assembly onto fuel tank.

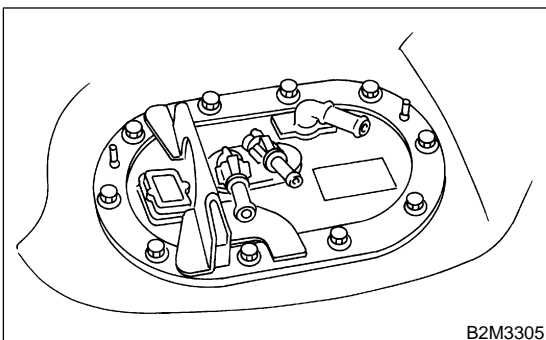

14) Take off fuel pump assembly from fuel tank.

B: INSTALLATION S105025A11

Install in the reverse order of removal. Do the following:

- (1) Always use new gaskets.
- (2) Ensure sealing portion is free from fuel or foreign particles before installation.
- (3) Tighten nuts in alphabetical sequence shown in figure to specified torque.

Tightening torque:

5.9 N·m (0.6 kgf·m, 4.3 ft·lb)

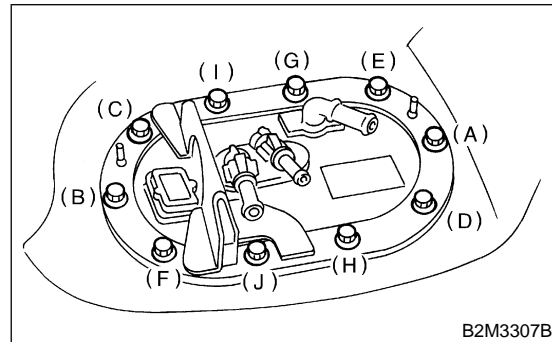

C: DISASSEMBLY S105025A06

1) Remove fuel pump and pump holder.

NOTE:

When disassembling pump holder, be careful as it is installed with two pawls.

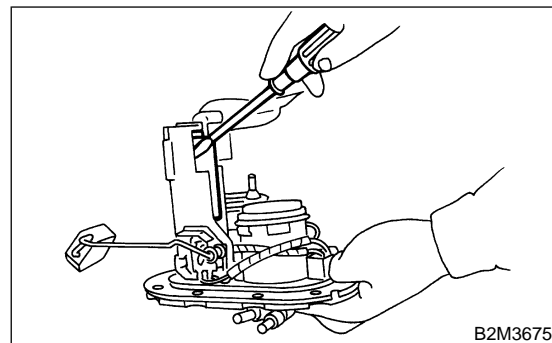

2) Disconnect connector from fuel pump.

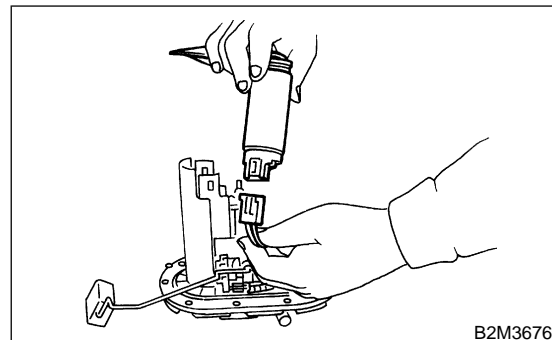

FUEL PUMP

Fuel Injection (Fuel Systems)

D: ASSEMBLY S105025A02

Assemble in the reverse order of disassembly.

E: INSPECTION S105025A10

Connect lead harness to connector terminal of fuel pump and apply battery power supply to check whether the pump operate.

WARNING:

- Wipe off the fuel completely.
- Keep battery as far apart from fuel pump as possible.
- Be sure to turn the battery supply ON and OFF on the battery side.
- Do not run fuel pump for a long time under non-load condition.

