

FUEL SUB LEVEL SENSOR

Fuel Injection (Fuel Systems)

26. Fuel Sub Level Sensor S105023

A: REMOVAL S105023A18

WARNING:

- Place "NO FIRE" signs near the working area.
- Be careful not to spill fuel on the floor.
- During work procedures, if fuel tank is more than 3/4 full, be careful because fuel may spill.

1) Disconnect battery ground cable.

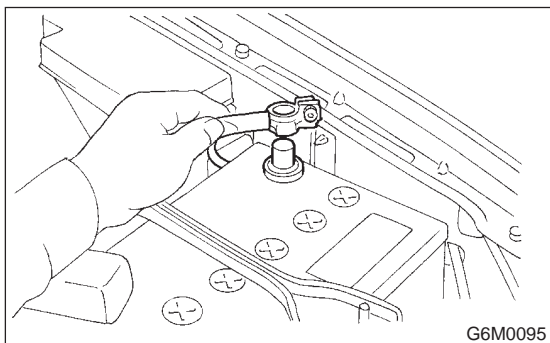

2) Lift-up the vehicle.

3) Remove front side fuel tank cover.

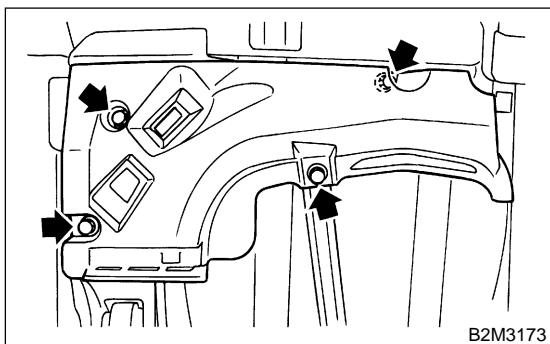

4) Drain fuel from fuel tank. Set a container under the vehicle and remove drain plug from fuel tank.

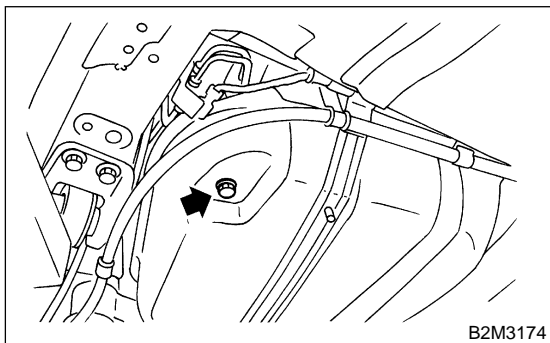

5) Tighten fuel drain plug and install front right side fuel tank cover.

Tightening torque:

26 N·m (2.65 kgf-m, 19.2 ft-lb)

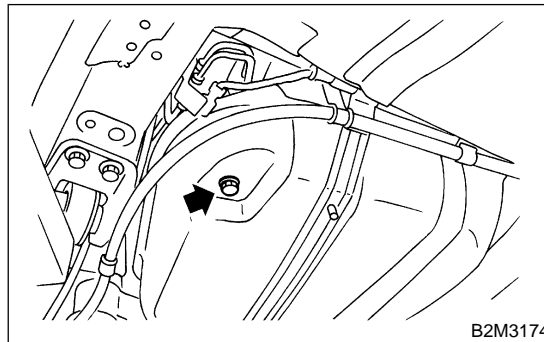

Tightening torque:

18 N·m (1.8 kgf-m, 13.0 ft-lb)

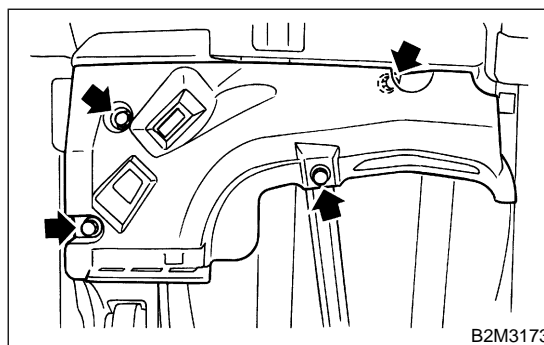

6) Raise rear seat and turn floor mat up. (Wagon model)

7) Remove rear seat. (Sedan model)

8) Remove service hole cover.

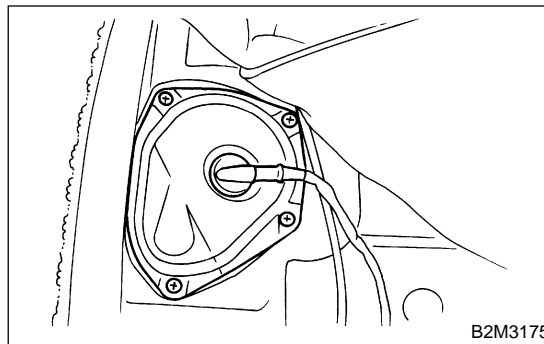

9) Disconnect connector from fuel sub level sensor.

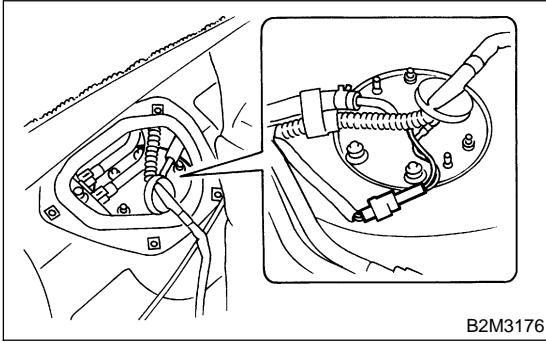

10) Disconnect fuel jet pump hose.

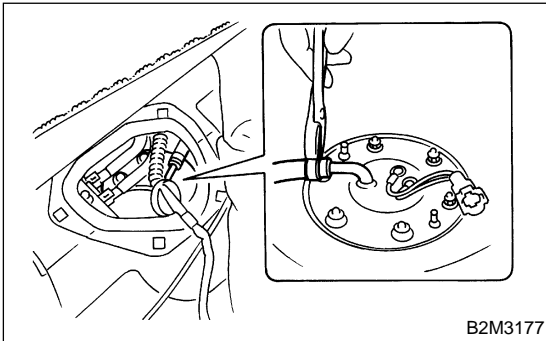

11) Remove bolts which install fuel sub level sensor on fuel tank.

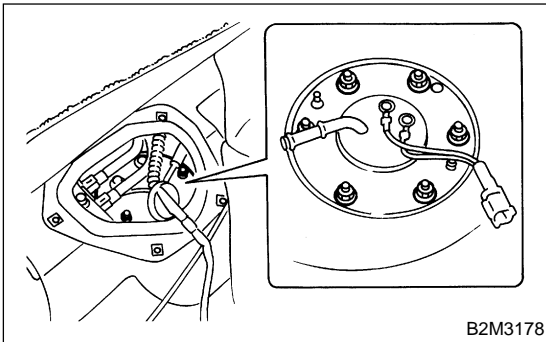

12) Remove fuel sub level sensor.

B: INSTALLATION S105023A11

Install in the reverse order of removal.

Tightening torque:
4.4 N·m (0.45 kgf-m, 3.3 ft-lb)

