

SPARK PLUG

Ignition

2. Spark Plug S101003

A: REMOVAL S101003A18

CAUTION:

All spark plugs installed on an engine, must be of the same heat range.

Spark plug:

CHAMPION: RC10YC4

(Alternate)

CHAMPION: RC8YC4

NGK: BKR6E-11

NIPPONDENSO: K20PR-U11

1. RH SIDE S101003A1805

- 1) Disconnect battery ground cable.

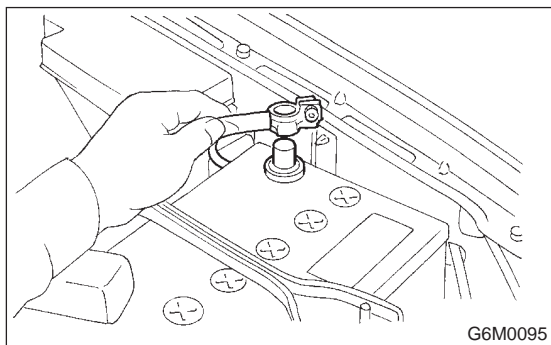

- 2) Remove air intake duct and resonator chamber.
(1) Remove bolt which installs air intake duct on the front side of body.

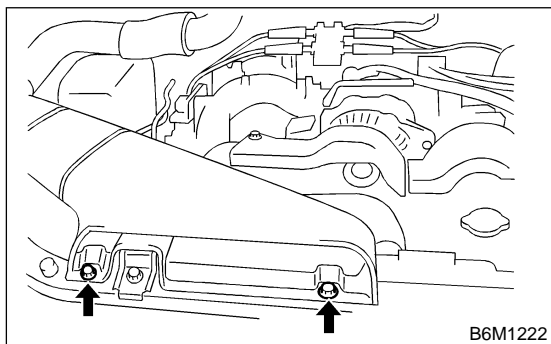

- (2) Remove bolt which installs air intake duct on body.

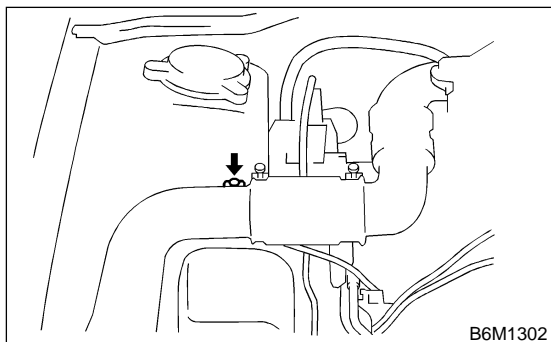

- (3) Remove air intake duct as a unit.

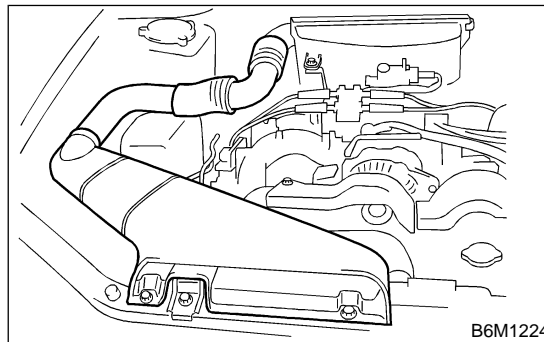

- (4) Remove resonator chamber.

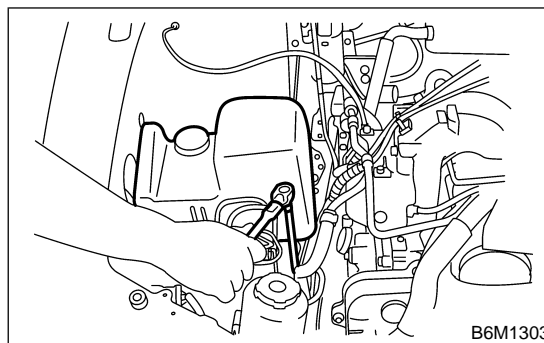

- 3) Remove spark plug cords by pulling boot, not cord itself.

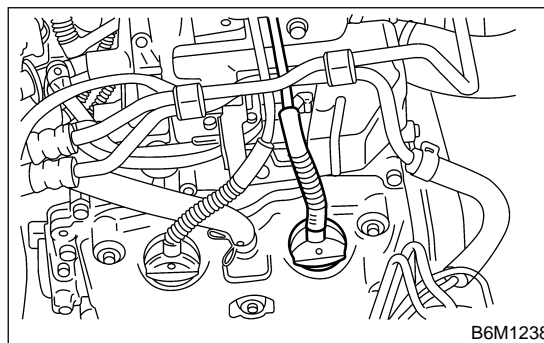

- 4) Remove spark plugs with the spark plug socket.

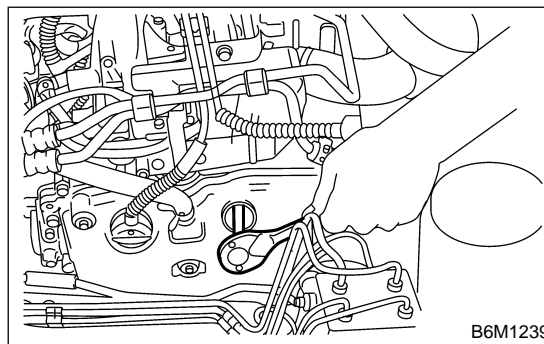

2. LH SIDE S101003A1806

- 1) Disconnect battery ground cable.

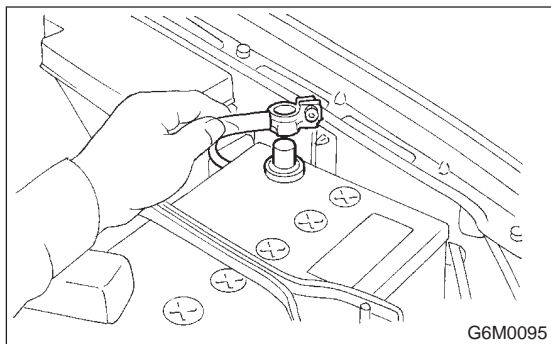

- 2) Disconnect washer motor connector.

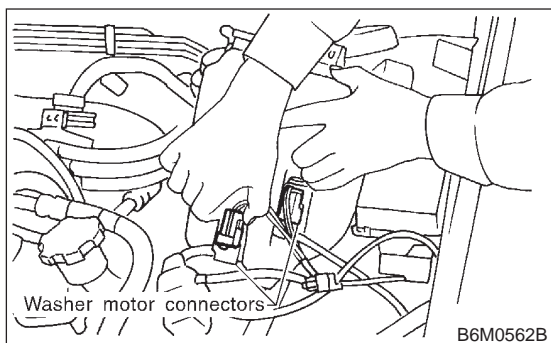

- 3) Disconnect rear window glass washer hose from washer motor, then plug connection with a suitable cap.
- 4) Remove the two bolts which hold the washer tank, then take the tank away from the working area.

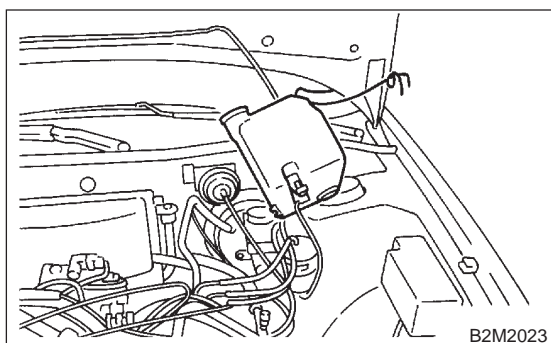

- 5) Remove spark plugs cord by pulling boot, not cord itself.

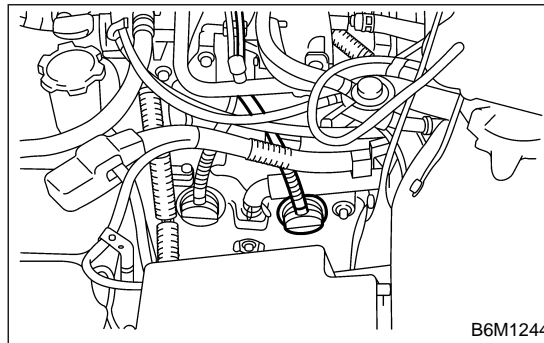

- 6) Remove spark plug with the spark plugs socket.

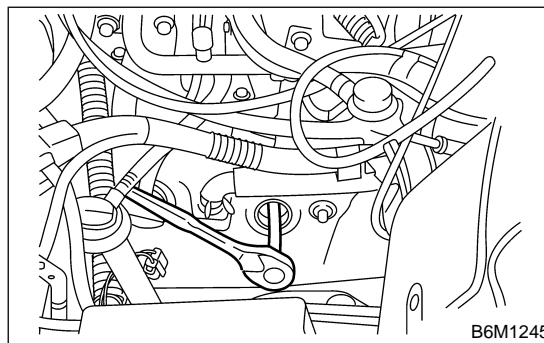

B: INSTALLATION S101003A11

1. RH SIDE S101003A1105

- 1) Install in the reverse order of removal.

Tightening torque (Spark plug):
 20.6 N·m (2.10 kgf-m, 15.2 ft-lb)

CAUTION:

The above torque should be only applied to new spark plugs without oil on their threads. In case their threads are lubricated, the torque should be reduced by approximately 1/3 of the specified torque in order to avoid over-stressing.

2. LH SIDE S101003A1106

- 1) Install in the reverse order of removal.

Tightening torque (Spark plug):
 20.6 N·m (2.10 kgf-m, 15.2 ft-lb)

CAUTION:

The above torque should be only applied to new spark plugs without oil on their threads. In case their threads are lubricated, the torque should be reduced by approximately 1/3 of the specified torque in order to avoid over-stressing.

SPARK PLUG

Ignition

C: INSPECTION S101003A10

Check electrodes and inner and outer porcelain of plugs, noting the type of deposits and the degree of electrode erosion.

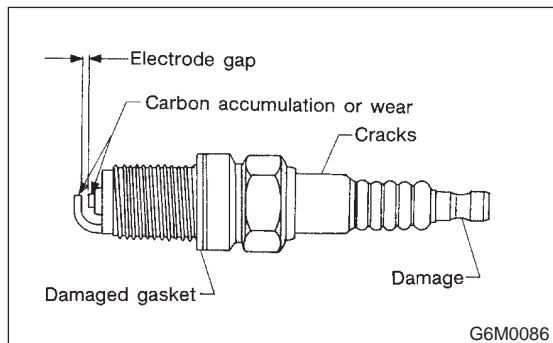

1) Normal

Brown to grayish-tan deposits and slight electrode wear indicate correct spark plug heat range.

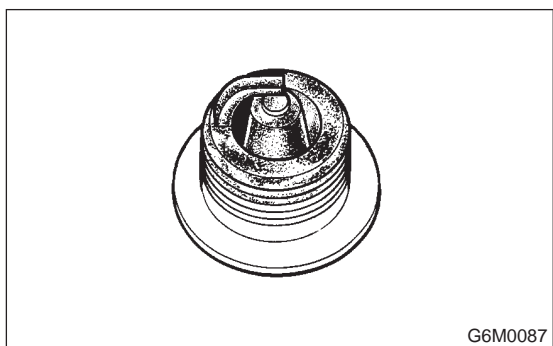

2) Carbon fouled

Dry fluffy carbon deposits on insulator and electrode are mostly caused by slow speed driving in city, weak ignition, too rich fuel mixture, dirty air cleaner, etc.

It is advisable to replace with plugs having hotter heat range.

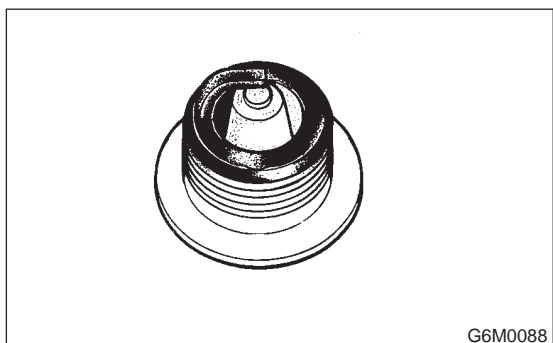

3) Oil fouled

Wet black deposits show excessive oil entrance into combustion chamber through worn rings and pistons or excessive clearance between valve guides and stems. If same condition remains after repair, use a hotter plug.

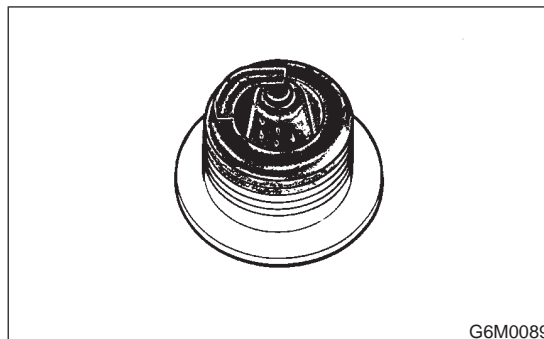

4) Overheating

White or light gray insulator with black or gray brown spots and bluish burnt electrodes indicate engine overheating. Moreover, the appearance results from incorrect ignition timing, loose spark plugs, wrong selection of fuel, hotter range plug, etc. It is advisable to replace with plugs having colder heat range.

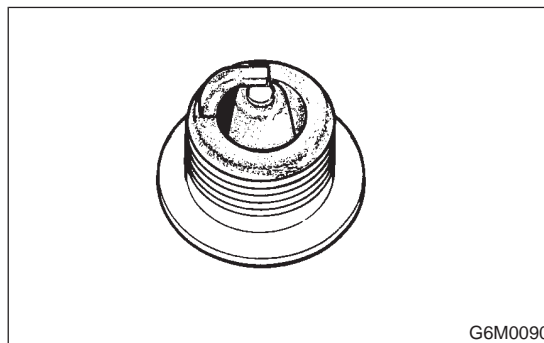

D: CLEANING S101003E56

Clean spark plugs in a sand blast type cleaner. Avoid excessive blasting. Clean and remove carbon or oxide deposits, but do not wear away porcelain.

If deposits are too stubborn, replace plugs.

E: ADJUSTMENT S101003A01

Correct it if the spark plug gap is measured with a gap gauge, and it is necessary.

Spark plug gap: L

1.0 — 1.1 mm (0.039 — 0.043 in)

