

## 4. Oil Pump S108070

### A: REMOVAL S108070A18

- 1) Disconnect battery ground cable.

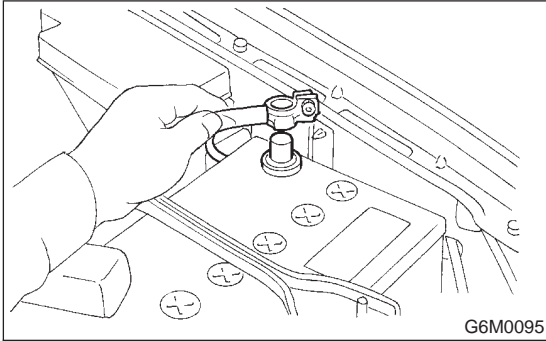

- 2) Lift-up the vehicle.
- 3) Remove under cover.

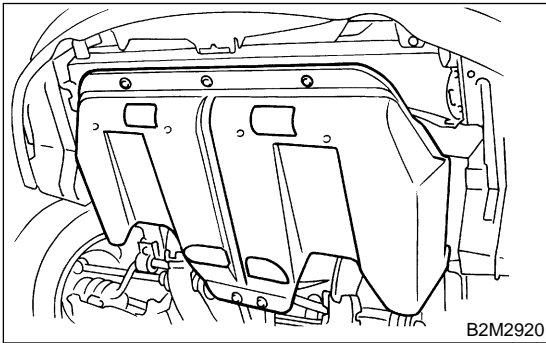

- 4) Drain coolant. <Ref. to CO(H4)-6 DRAINING OF ENGINE COOLANT, REPLACEMENT, Engine Coolant.>

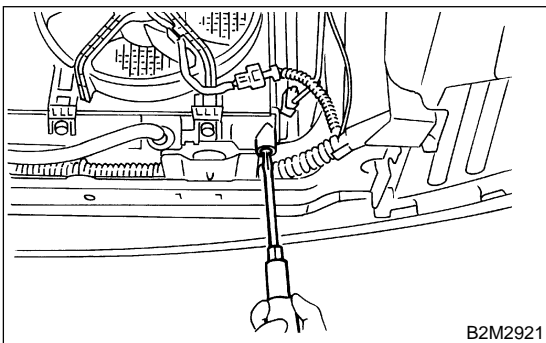

- 5) Lower the vehicle.
- 6) Remove radiator. <Ref. to CO(H4)-15 REMOVAL, Radiator.>

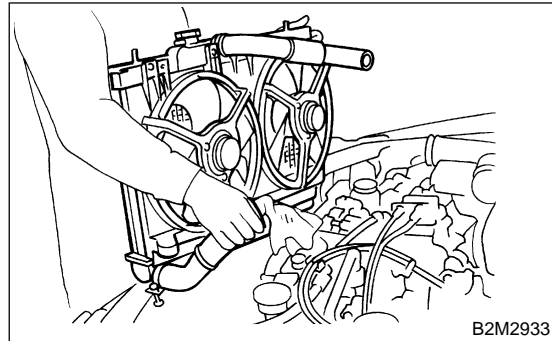

- 7) Remove crankshaft position sensor.

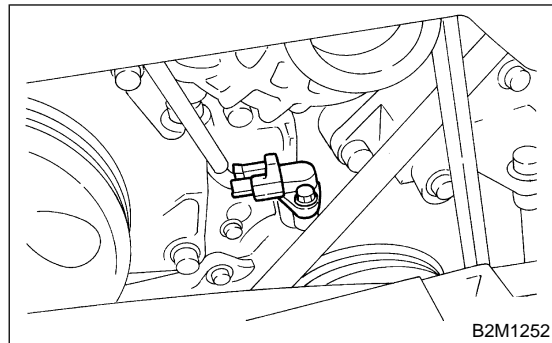

- 8) Remove V-belts. <Ref. to ME(H4)-43 REMOVAL, V-belt.>

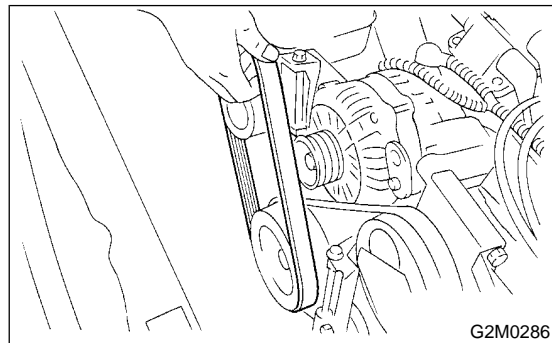

- 9) Remove rear side V-belt tensioner.

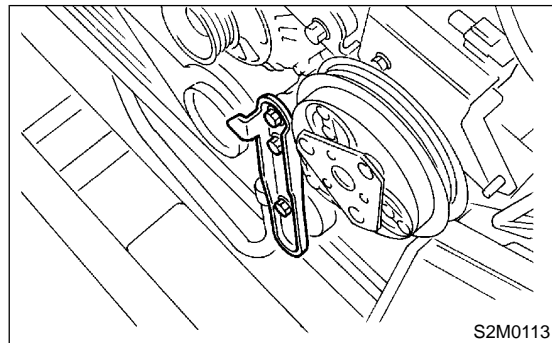

# OIL PUMP

Lubrication

- 10) Remove crankshaft pulley by using ST.  
ST 499977100 CRANKSHAFT PULLEY  
WRENCH

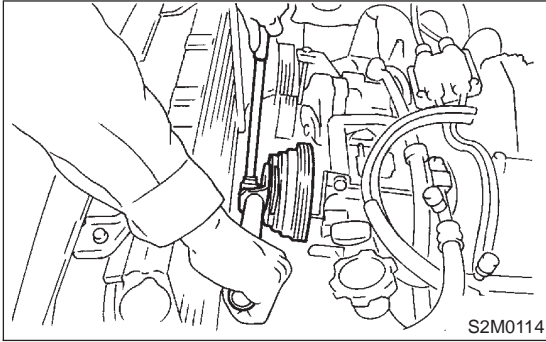

- 11) Remove water pump. <Ref. to CO(H4)-8  
REMOVAL, Water Pump.>

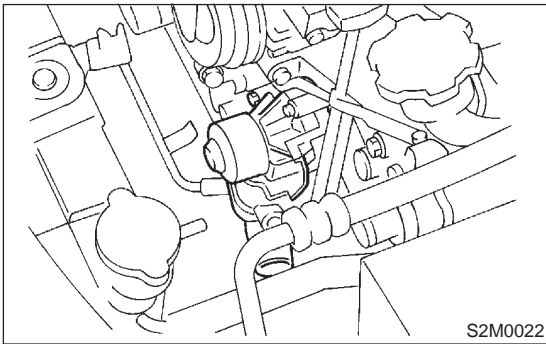

- 12) Remove timing belt guide. (MT vehicles only)

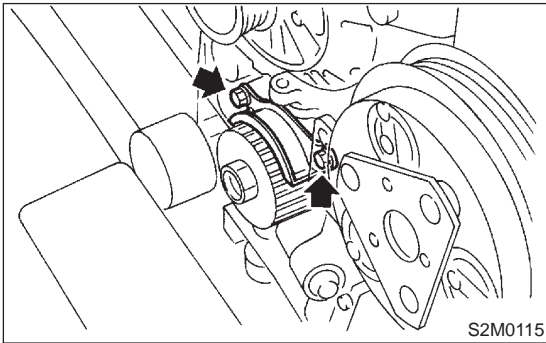

- 13) Remove crankshaft sprocket.

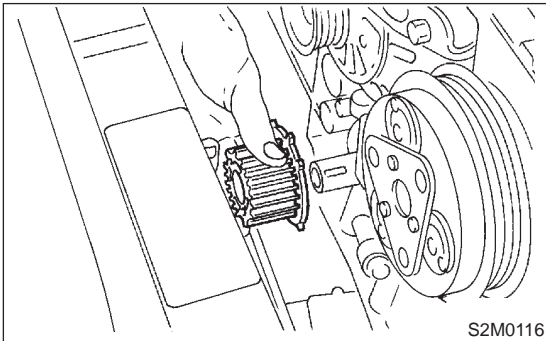

- 14) Remove bolts which install oil pump onto cyl-  
inder block.

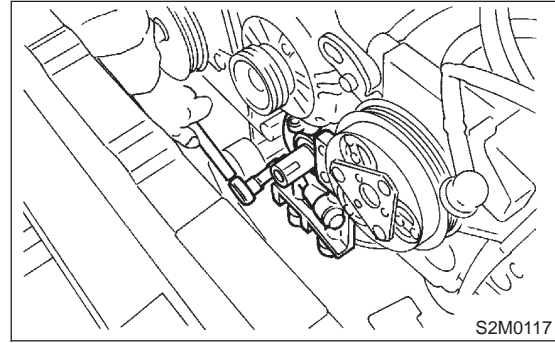

- 15) Remove oil pump by using flat bladed screw-  
driver.

### CAUTION:

Be careful not to scratch mating surfaces of  
cylinder block and oil pump.

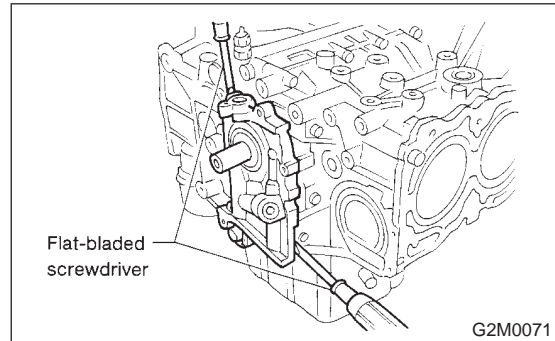

## B: INSTALLATION

S108070A11

Install in the reverse order of removal.

Do the following:

- 1) Apply fluid packing to matching surfaces of oil  
pump.

**Fluid packing:**

**THREE BOND 1215 or equivalent**

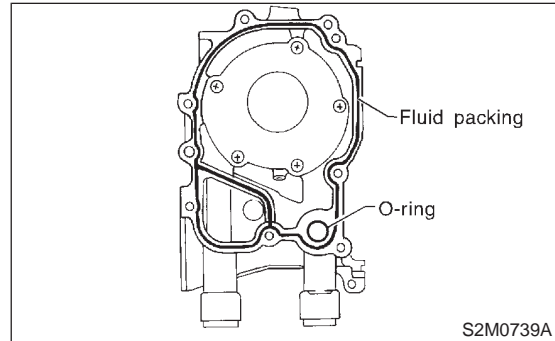

- 2) Replace O-ring with a new one.

LU(H4)-10

3) Apply a coat of engine oil to the inside of the oil seal.

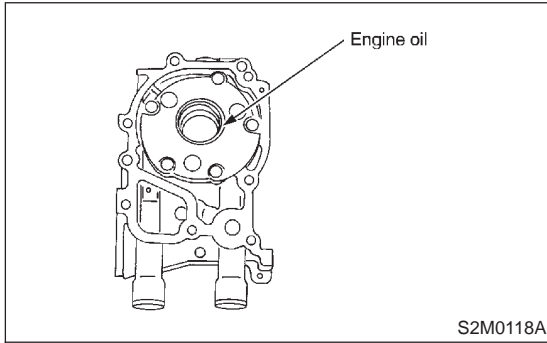

4) Be careful not to scratch oil seal when installing oil pump on cylinder block.  
 5) Position the oil pump, aligning the notched area with the crankshaft, and push the oil pump straight.

**CAUTION:**  
**Make sure the oil seal lip is not folded.**

6) Install oil pump.

**Tightening torque:**  
**6.4 N·m (0.65 kgf·m, 4.7 ft·lb)**

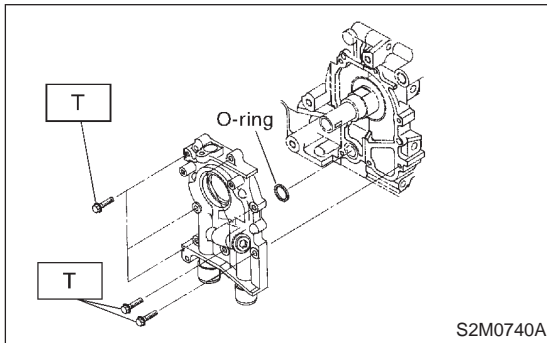

## C: DISASSEMBLY S108070A06

Remove screws which secure oil pump cover and disassemble oil pump. Inscribe alignment marks on inner and outer rotors so that they can be replaced in their original positions during reassembly.

**CAUTION:**  
**Before removing relief valve, loosen plug when removing oil pump from cylinder block.**

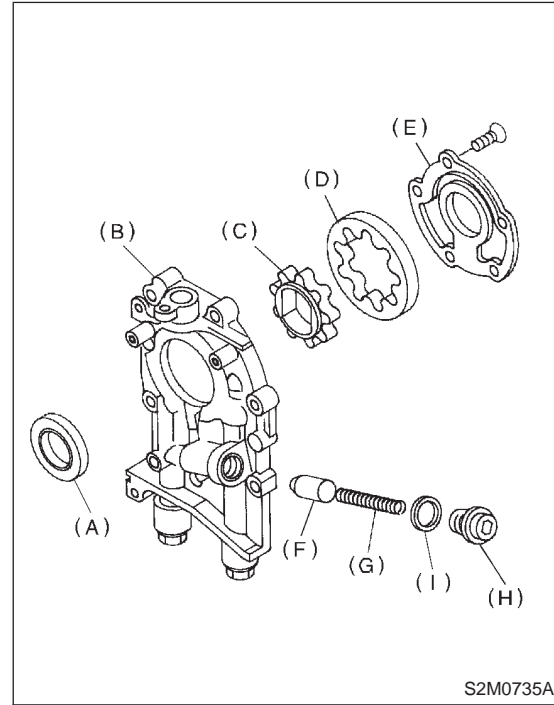

- (A) Oil seal
- (B) Pump case
- (C) Inner rotor
- (D) Outer rotor
- (E) Pump cover
- (F) Relief valve
- (G) Relief spring
- (H) Plug
- (I) Washer

## D: ASSEMBLY S108070A02

- 1) Install front oil seal by using ST.  
ST 499587100 OIL SEAL INSTALLER

**CAUTION:**  
Use a new oil seal.

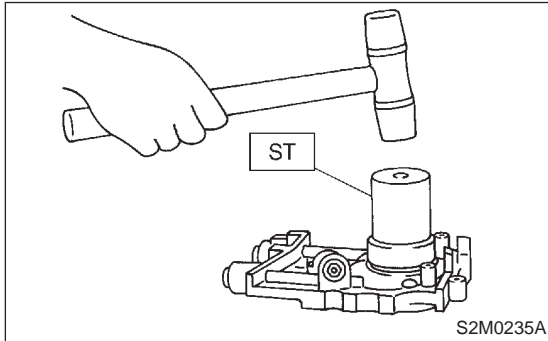

- 2) Apply a coat of engine oil to inner and outer rotors.
- 3) Install inner and outer rotors in their original positions.
- 4) Install oil relief valve and relief spring.
- 5) Install oil pump cover.

**Tightening torque:**

**T1: 5 N·m (0.5 kgf-m, 3.6 ft-lb)**

**T2: 44.1 N·m (4.5 kgf-m, 32.5 ft-lb)**

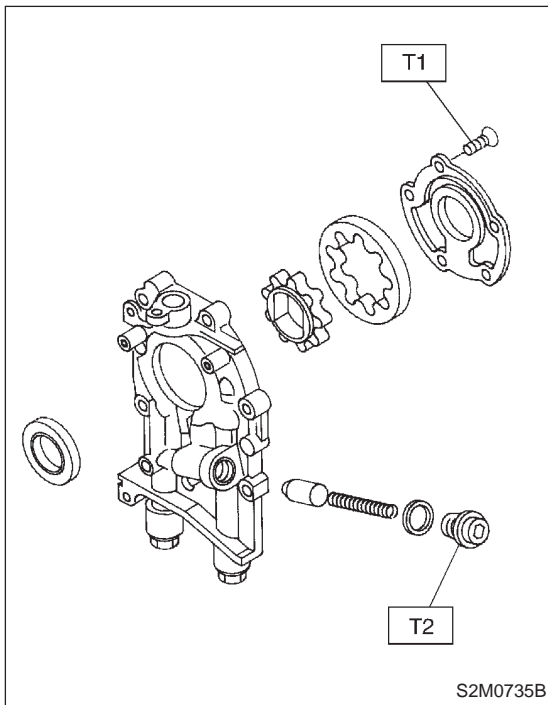

## E: INSPECTION S108070A10

### 1. TIP CLEARANCE S108070A1001

Measure the tip clearance of rotors. If the clearance exceeds the limit, replace rotors as a matched set.

**Tip clearance:**

**Standard**

**0.04 — 0.14 mm (0.0016 — 0.0055 in)**

**Limit**

**0.18 mm (0.0071 in)**

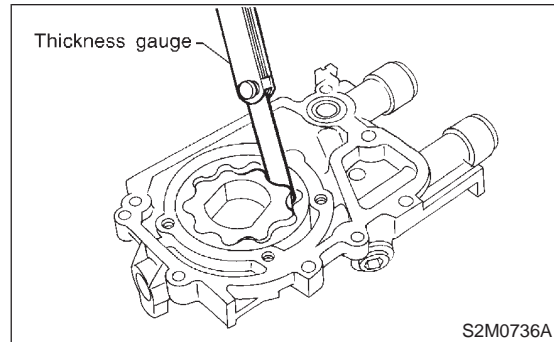

### 2. CASE CLEARANCE S108070A1002

Measure the clearance between the outer rotor and the cylinder block rotor housing. If the clearance exceeds the limit, replace the rotor.

**Case clearance:**

**Standard**

**0.10 — 0.175 mm (0.0039 — 0.0069 in)**

**Limit**

**0.20 mm (0.0079 in)**

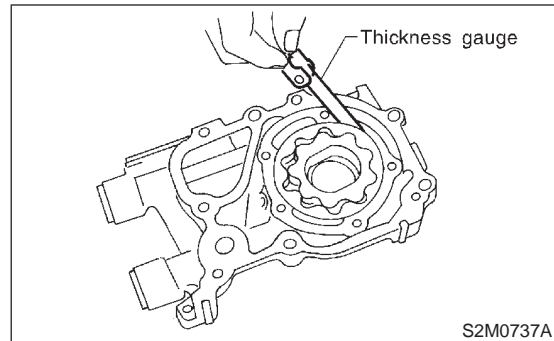

**3. SIDE CLEARANCE** S108070A1003

Measure clearance between oil pump inner rotor and pump cover. If the clearance exceeds the limit, replace rotor or pump body.

**Side clearance:****Standard**

**0.02 — 0.07 mm (0.0008 — 0.0028 in)**

**Limit**

**0.15 mm (0.0059 in)**

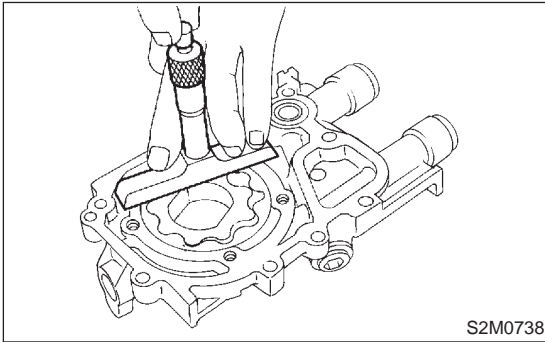
**4. OIL RELIEF VALVE** S108070A1004

Check the valve for fitting condition and damage, and the relief valve spring for damage and deterioration. Replace the parts if defective.

**Relief valve spring:****Free length**

**71.8 mm (2.827 in)**

**Installed length**

**54.7 mm (2.154 in)**

**Load when installed**

**77.08 N (7.86 kg, 17.33 lb)**

**5. OIL PUMP CASE** S108070A1005

Check the oil pump case for worn shaft hole, clogged oil passage, worn rotor chamber, cracks, and other faults.

**6. OIL SEAL** S108070A1006

Check the oil seal lips for deformation, hardening, wear, etc. and replace if defective.