

FUEL PRESSURE

Mechanical

7. Fuel Pressure S103656

A: INSPECTION S103656A10

WARNING:

Before removing fuel pressure gauge, release fuel pressure.

NOTE:

If out of specification, check or replace pressure regulator and pressure regulator vacuum hose.

1) Release fuel pressure. <Ref. to FU(H4)-xx RELEASING OF FUEL PRESSURE OPERATION, Fuel.>

2) Open fuel flap lid, and remove fuel filler cap.

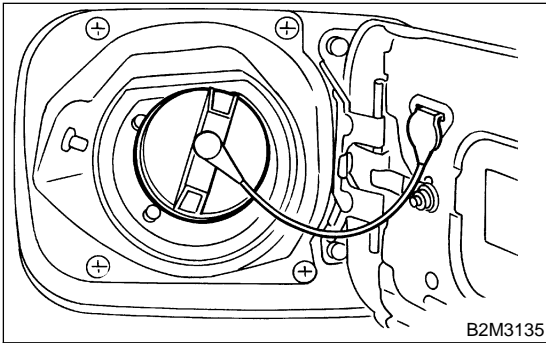

3) Disconnect fuel delivery hoses from fuel filter, and connect fuel pressure gauge.

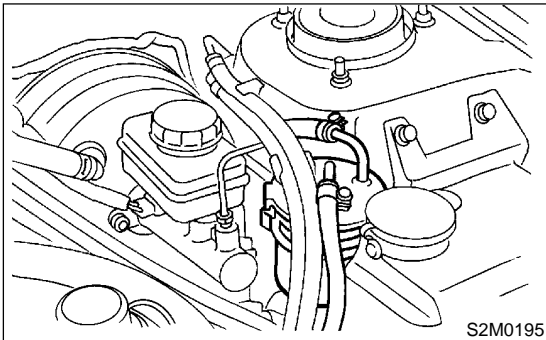

4) Connect connector of fuel pump relay.

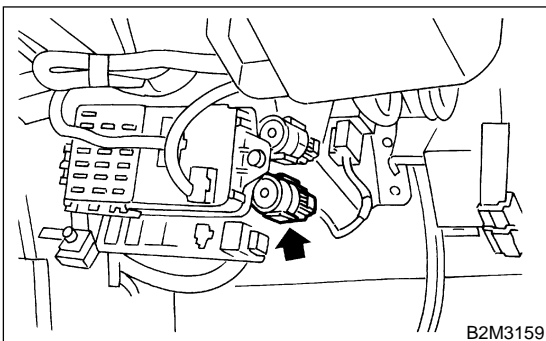

5) Start the engine.

6) Measure fuel pressure while disconnecting pressure regulator vacuum hose from intake manifold.

Fuel pressure:

Standard; 284 — 314 kPa (2.9 — 3.2 kg/cm², 41 — 46 psi)

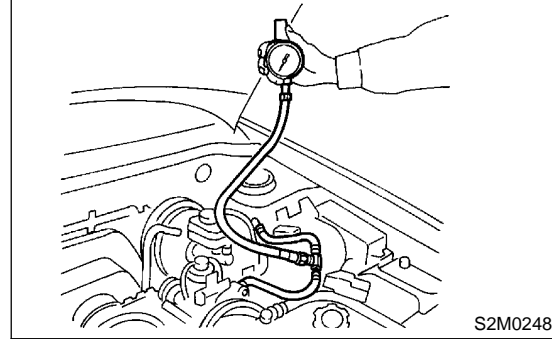

7) After connecting pressure regulator vacuum hose, measure fuel pressure.

Fuel pressure:

Standard; 206 — 235 kPa (2.1 — 2.4 kg/cm², 30 — 34 psi)

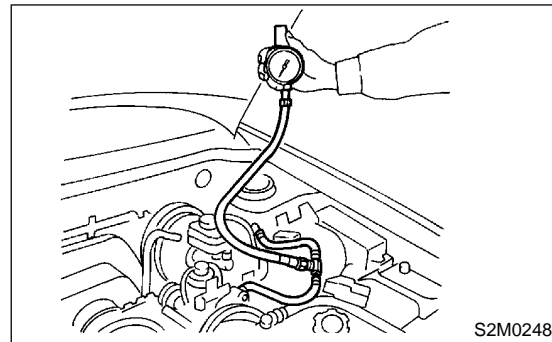

NOTE:

The fuel pressure gauge registers 10 to 20 kPa (0.1 to 0.2 kg/cm², 1 to 3 psi) higher than standard values during high-altitude operations.