

## 8. Valve Clearance S103083

### A: INSPECTION S103083A10

**CAUTION:**  
Inspection and adjustment of valve clearance should be performed while engine is cold.

- 1) Set the vehicle onto the lift.
- 2) Lift-up the vehicle.
- 3) Remove under cover.

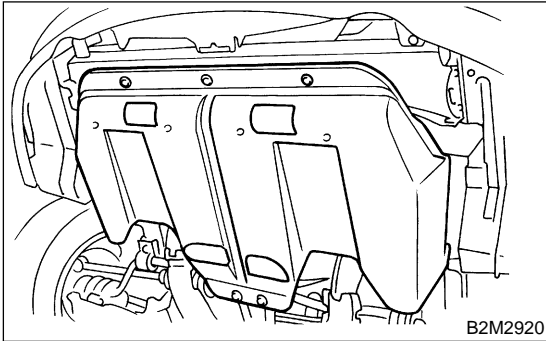

- 4) Disconnect battery ground cable.

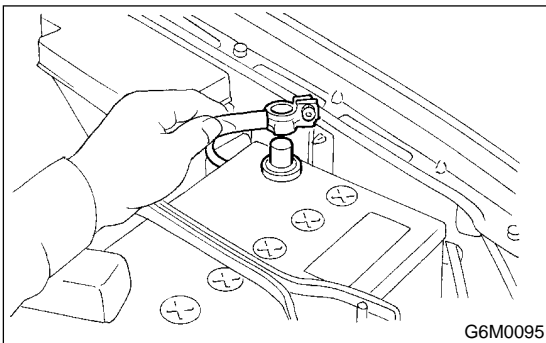

- 5) Lower the vehicle.
- 6) Remove timing belt cover (LH).

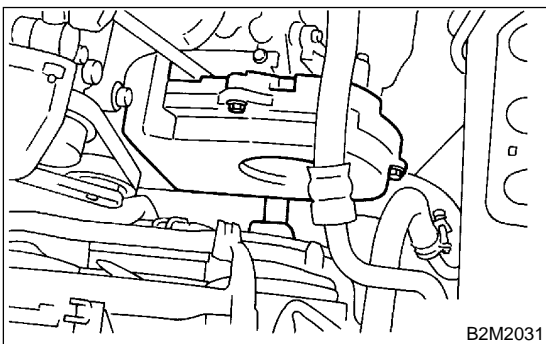

- 7) Remove rocker cover.
- 8) When inspecting #1 and #3 cylinders;
  - (1) Remove bolt which secures air intake duct to radiator panel side.
  - (2) Remove air intake duct as a unit.

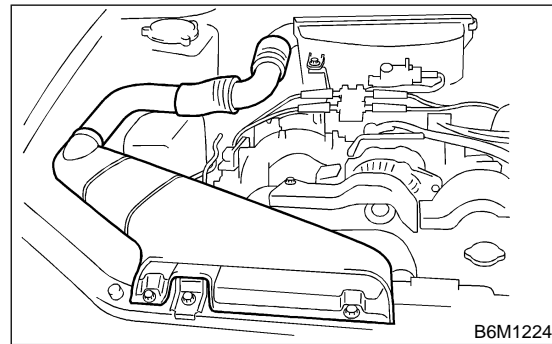

- (3) Remove bolt, and then remove resonator chamber.

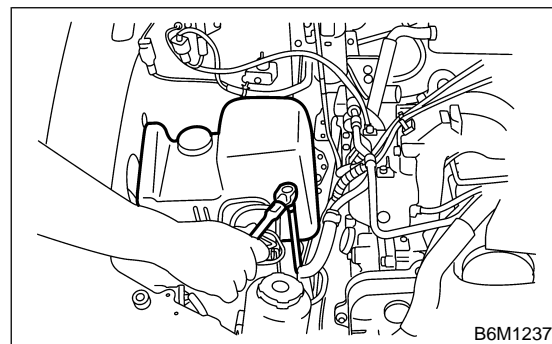

- (4) Disconnect spark plug cords from spark plugs (#1 and #3 cylinders).

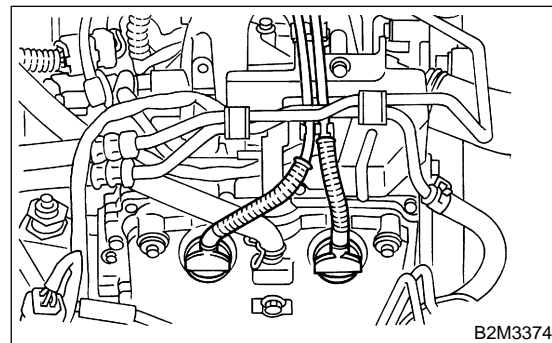

- (5) Disconnect PCV hose from rocker cover (RH).
- (6) Remove bolts, then remove rocker cover (RH).

# VALVE CLEARANCE

Mechanical

- 9) When inspecting #2 and #4 cylinders;  
(1) Disconnect battery cables, and then remove battery and battery carrier.

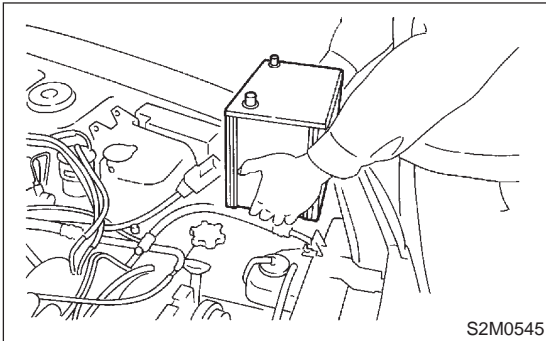

- (2) Remove the two bolts which hold washer tank.

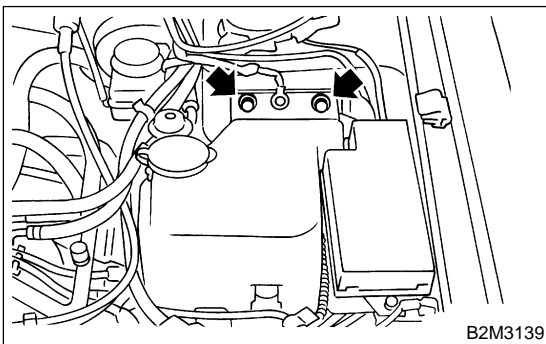

- (3) Disconnect washer motor connectors.

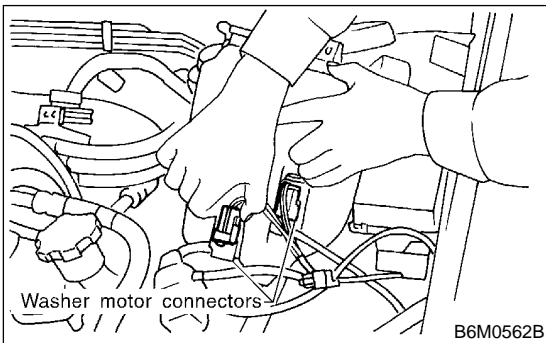

- (4) Move washer tank to forward.

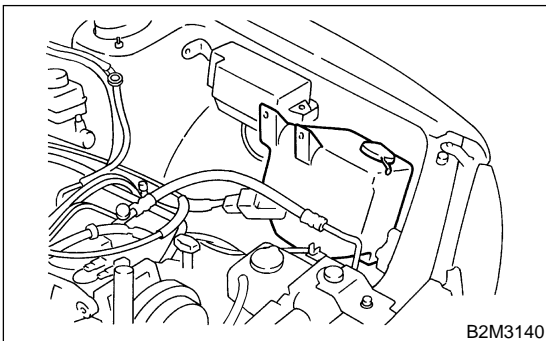

- (5) Disconnect spark plug cords from spark plugs (#2 and #4 cylinders).

- (6) Disconnect PCV hose from rocker cover (LH).  
(7) Remove bolts, then remove rocker cover (LH).

- 10) Set #1 cylinder piston to top dead center of compression stroke by rotating crankshaft pulley clockwise using ST.

ST 499977100 CRANKSHAFT PULLEY WRENCH

### NOTE:

When arrow mark on camshaft sprocket (LH) comes exactly to the top, #1 cylinder piston is brought to the top dead center of compression stroke.

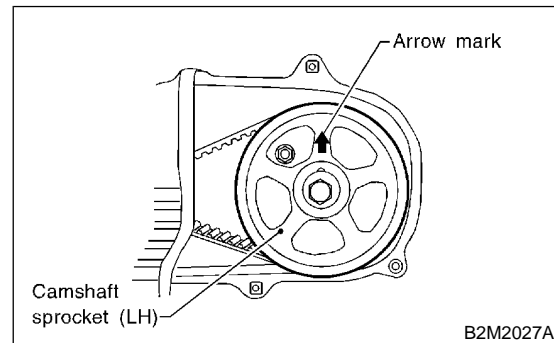

- 11) Measure #1 cylinder valve clearance by using thickness gauge.

### CAUTION:

- Insert the thickness gauge in as horizontal a direction as possible with respect to the valve stem end face.
- Measure exhaust valve clearances while lifting-up the vehicle.

### Valve clearance:

#### Intake;

$0.20 \pm 0.02 \text{ mm} (0.0079 \pm 0.0008 \text{ in})$

#### Exhaust;

$0.25 \pm 0.02 \text{ mm} (0.0098 \pm 0.0008 \text{ in})$

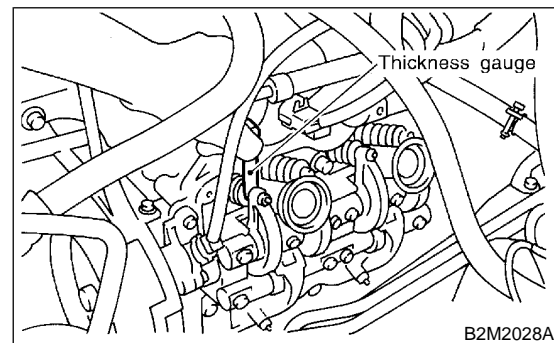

- 12) If necessary, adjust the valve clearance. <Ref. to ME(H4)-31 ADJUSTMENT, Valve Clearance.>

ME(H4)-30

13) Similar to measurement procedures used for #1 cylinder, measure #2, #3 and #4 cylinder valve clearances.

**NOTE:**

- Be sure to set cylinder pistons to their respective top dead centers on compression stroke before measuring valve clearances.
- To set #3, #2 and #4 cylinder pistons to their top dead centers on compression stroke, turn crankshaft pulley clockwise 90° at a time starting with arrow mark on left-hand camshaft sprocket facing up.

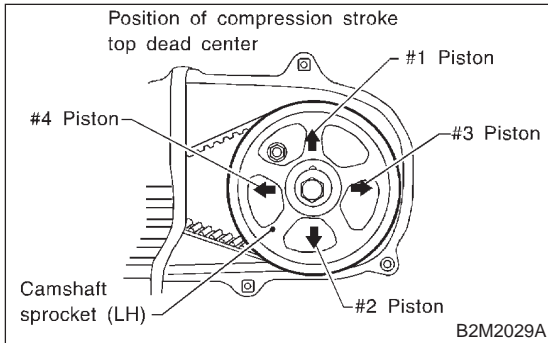

14) After inspection, install the related parts in the reverse order of removal.

**Tightening torque:**

**Resonator chamber;**  
**32 N·m (3.3 kgf·m, 24 ft·lb)**

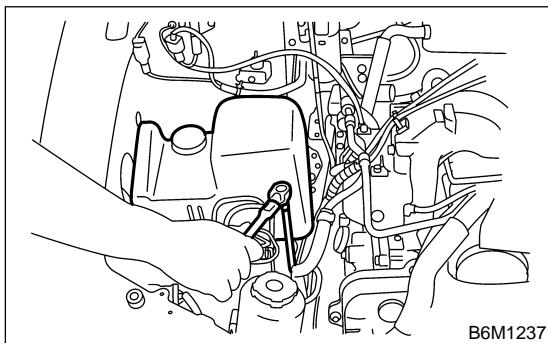

## B: ADJUSTMENT

S103083A01

**CAUTION:**

Adjustment of valve clearance should be performed while engine is cold.

1) Set #1 cylinder piston to top dead center of compression stroke by rotating crankshaft pulley clockwise using ST.

ST 499977100 CRANKSHAFT PULLEY WRENCH

**NOTE:**

When arrow mark on camshaft sprocket (LH) comes exactly to the top, #1 cylinder piston is brought to the top dead center of compression stroke.

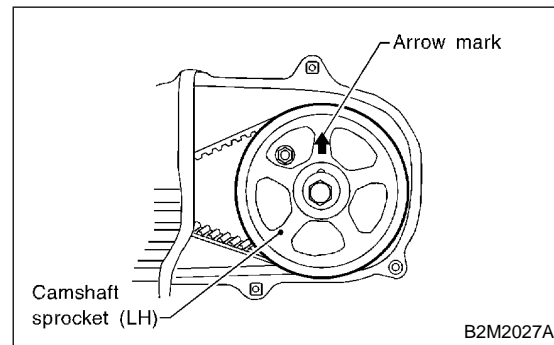

2) Adjust the #1 cylinder valve clearance.

- (1) Loosen the valve rocker nut and screw.
- (2) Place suitable thickness gauge.
- (3) While noting valve clearance, tighten valve rocker adjust screw.
- (4) When specified valve clearance is obtained, tighten valve rocker nut.

**Tightening torque:**

**10 N·m (1.0 kgf·m, 7.2 ft·lb)**

**CAUTION:**

- Insert the thickness gauge in as horizontal a direction as possible with respect to the valve stem end face.
- Adjust exhaust valve clearances while lifting-up the vehicle.

**Valve clearance:**

**Intake;**

**0.20±0.02 mm (0.0079±0.0008 in)**

**Exhaust;**

**0.25±0.02 mm (0.0098±0.0008 in)**

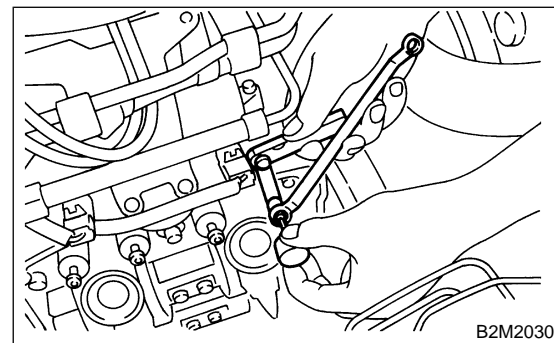

3) Ensure that valve clearances are within specifications.

# VALVE CLEARANCE

Mechanical

4) Turn crankshaft two complete rotations until #1 cylinder piston is again set to top dead center on compression stroke.

5) Ensure that valve clearances are within specifications. If necessary, readjust valve clearances.

6) Similar to adjustment procedures used for #1 cylinder, adjust #2, #3 and #4 cylinder valve clearances.

## NOTE:

- Be sure to set cylinder pistons to their respective top dead centers on compression stroke before adjusting valve clearances.

- To set #3, #2 and #4 cylinder pistons to their top dead centers on compression stroke, turn crankshaft pulley clockwise 90° at a time starting with arrow mark on left-hand camshaft sprocket facing up.

