

9. Engine Assembly S103079

A: REMOVAL S103079A18

- 1) Set the vehicle on lift arms.
- 2) Open front hood fully and support with stay.
- 3) Raise rear seat, and turn floor mat up.
- 4) Release fuel pressure. <Ref. to FU(H4)-70 RELEASING OF FUEL PRESSURE, OPERATION, Fuel.>
- 5) Remove filler cap.
- 6) Disconnect battery ground terminal.

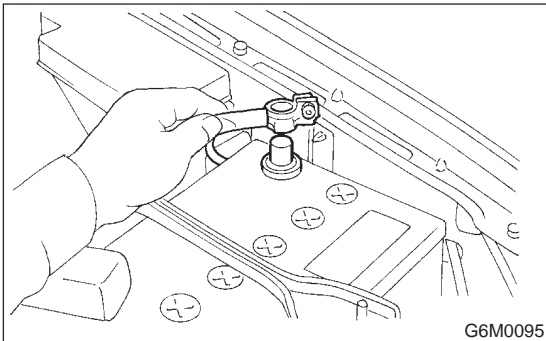

- 7) Remove air intake duct and air cleaner case. <Ref. to IN(H4)-7, REMOVAL, Air Intake Duct.> and <Ref. to IN(H4)-6 REMOVAL, Air Cleaner Case.>

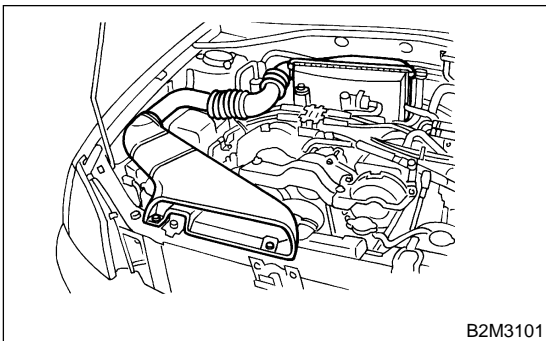

- 8) Remove under cover.
- 9) Drain coolant.

Set container under the vehicle, and loose drain cock from radiator. <Ref. to CO(H4)-6 DRAINING OF ENGINE COOLANT, REPLACEMENT, Engine Coolant.>

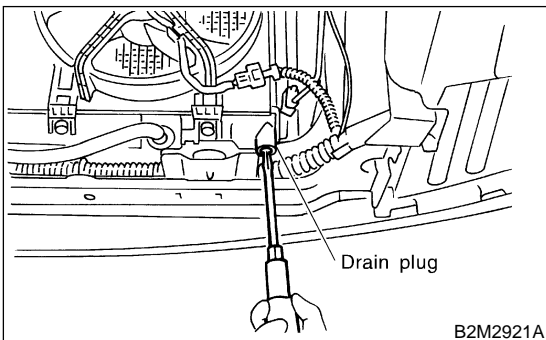

- 10) Remove radiator from vehicle. <Ref. to CO(H4)-15 REMOVAL, Radiator.>

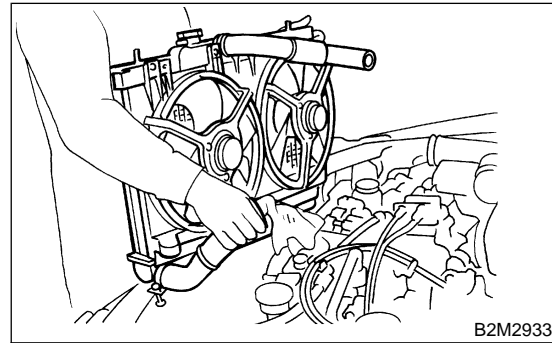

- 11) Remove V-belt cover.

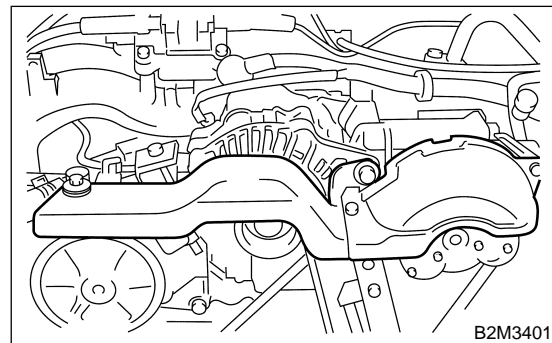

- 12) Collect refrigerant, and remove pressure hoses. (With A/C)

- (1) Place and connect the attachment hose to the refrigerant recycle system.
- (2) Collect refrigerant from A/C system.
- (3) Disconnect A/C pressure hoses from A/C compressor.

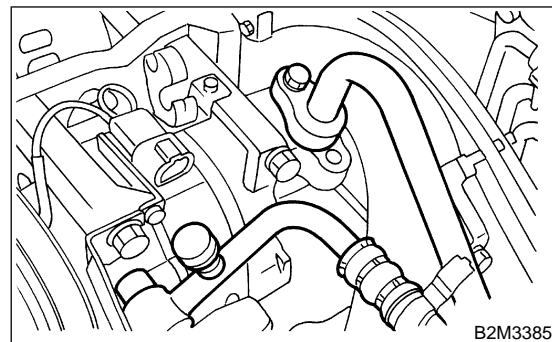

ENGINE ASSEMBLY

Mechanical

13) Remove air cleaner case stay.

● **MT model**

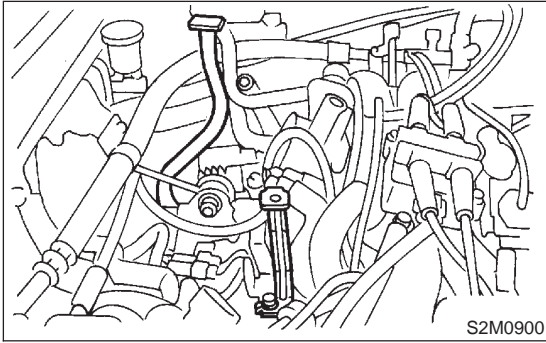

● **AT model**

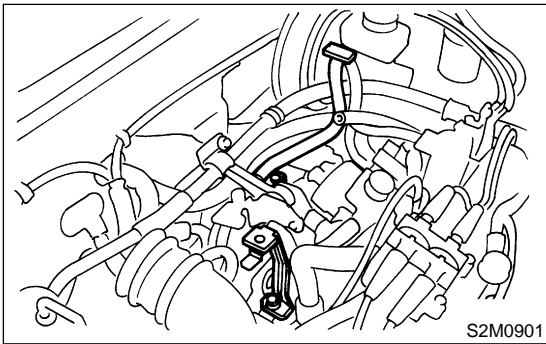

14) Disconnect the following connectors and cables.

(1) Front oxygen sensor connector

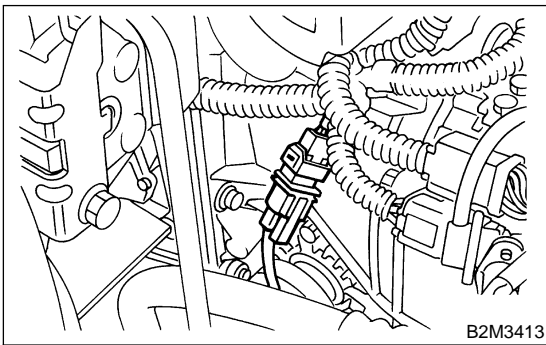

(2) Engine ground terminal

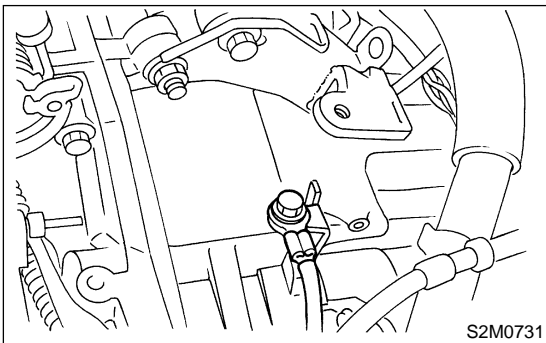

(3) Engine harness connectors

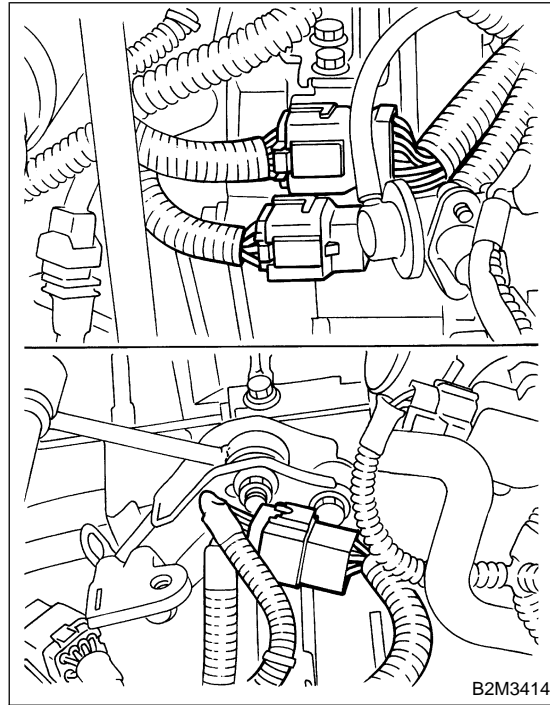

(4) Alternator connector, terminal and A/C compressor connector

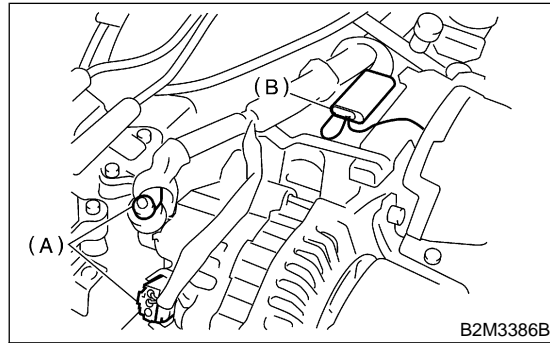

(A) A/C compressor connector
(B) Alternator connector and terminal

(5) Accelerator cable and cruise control cable

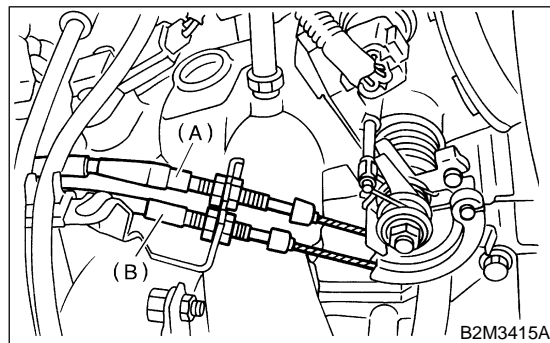

(A) Accelerator cable
(B) Cruise control cable

(6) Pressure switch

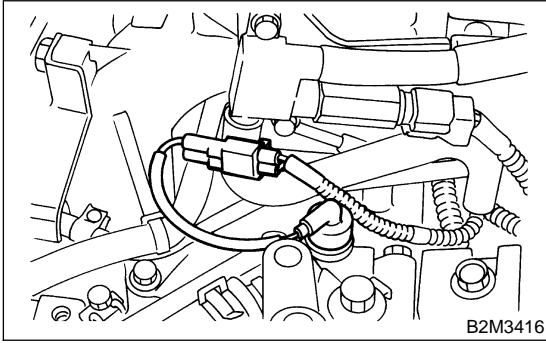

15) Disconnect the following hoses.

(1) Brake booster vacuum hose

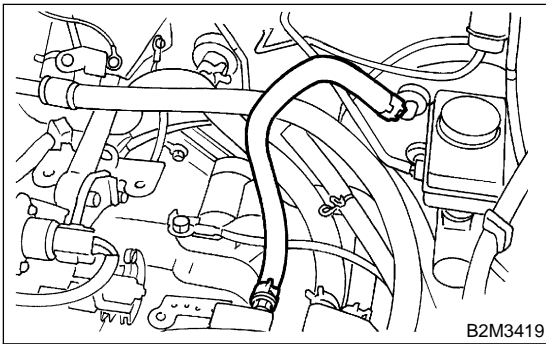

(2) Heater inlet outlet hose

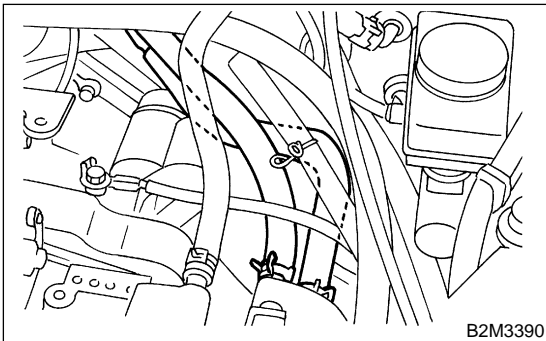

16) Remove power steering pump from bracket.

(1) Remove resonator chamber.

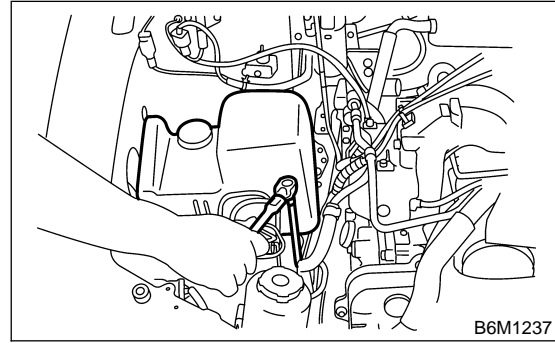

(2) Loosen lock bolt and slider bolt, and remove front side V-belt.

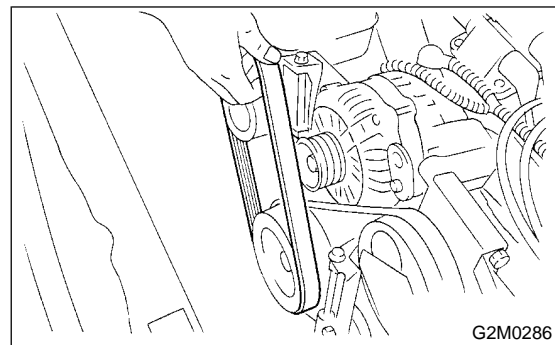

(3) Remove pipe with bracket.

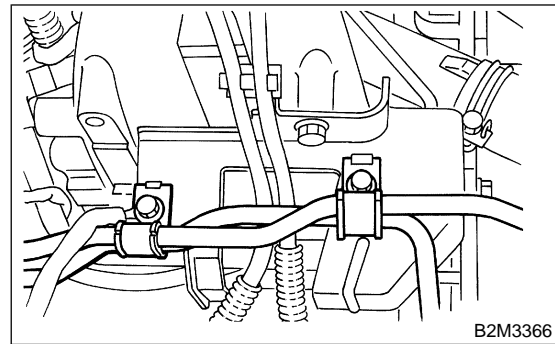

(4) Remove bolts which install power steering pump bracket.

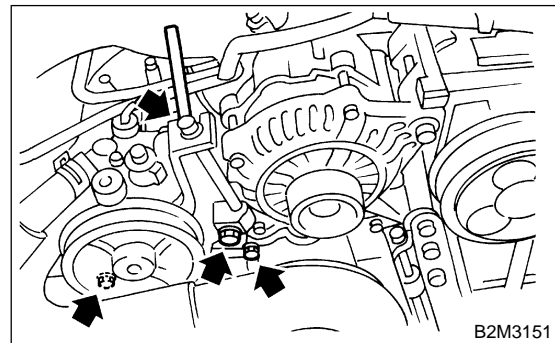

ENGINE ASSEMBLY

Mechanical

(5) Remove power steering tank from the bracket by pulling it upward.

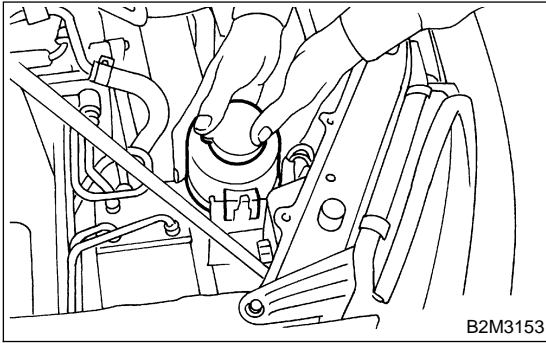

(6) Place power steering pump on the right side wheel apron.

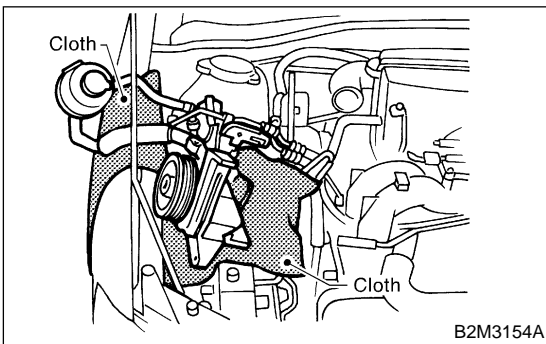

17) Remove front and center exhaust pipe.
<Ref. to EX(H4)-5 REMOVAL, Front Exhaust Pipe.> and <Ref. to EX(H4)-8 REMOVAL, Center Exhaust Pipe.>

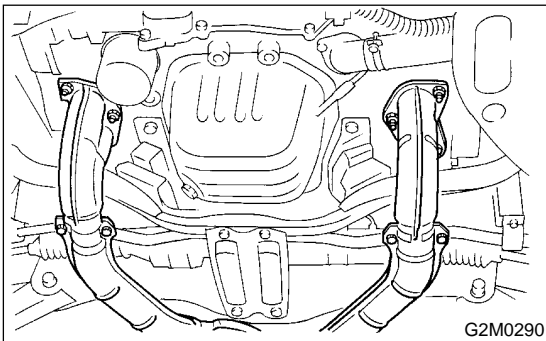

18) Remove nuts which hold lower side of transmission to engine.

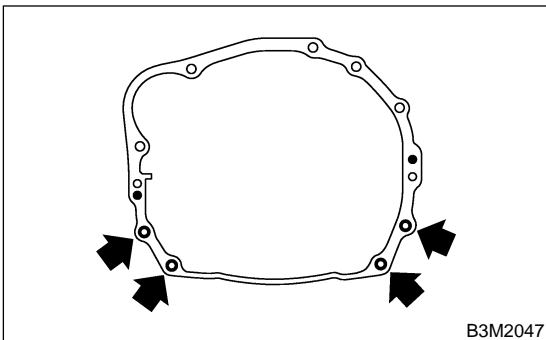

19) Remove nuts which install front cushion rubber onto front crossmember.

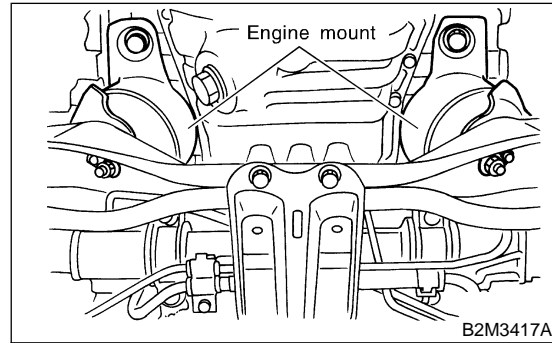

20) Separate torque converter clutch from drive plate. (AT model)

- (1) Lower the vehicle.
- (2) Remove service hole plug.
- (3) Remove bolts which hold torque converter clutch to drive plate.
- (4) Remove other bolts while rotating the engine using ST.

ST 499977100 CRANK PULLEY WRENCH

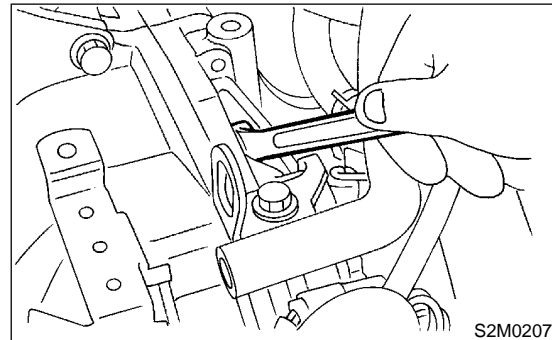

21) Remove pitching stopper.

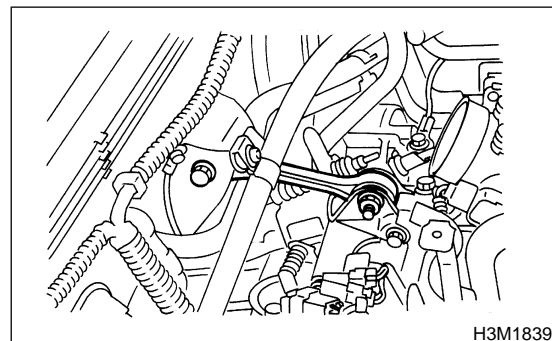

22) Disconnect fuel delivery hose, return hose and evaporation hose.

CAUTION:

- Disconnect hose with its end wrapped with cloth to prevent fuel from splashing.
- Catch fuel from hose into container.

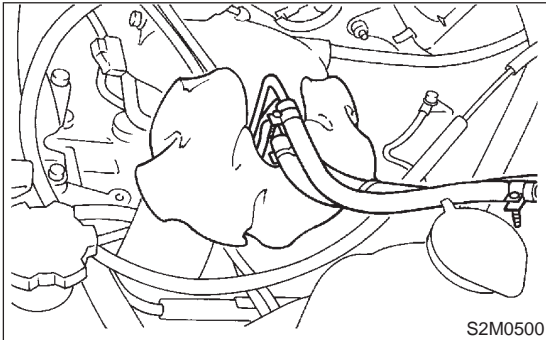

23) Support engine with a lifting device and wire ropes.

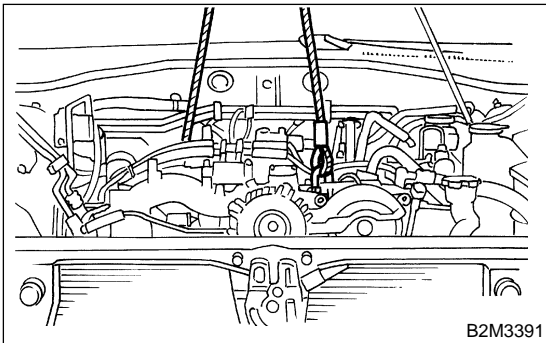

24) Support transmission with a garage jack.

CAUTION:

Before moving engine away from transmission, check to be sure no work has been overlooked. Doing this is very important in order to facilitate re-installation and because transmission lowers under its own weight.

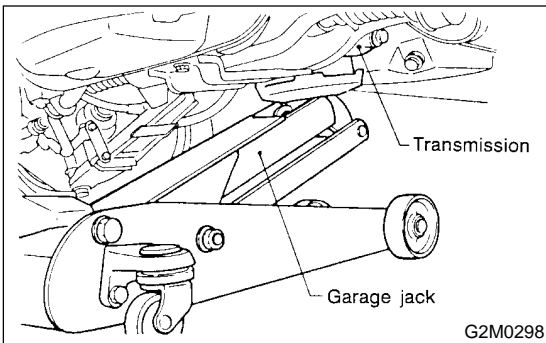

25) Separation of engine and transmission.

- (1) Remove starter. <Ref. to SC(H4)-7 REMOVAL, Starter.>
- (2) Remove bolts which hold upper side of transmission to engine.

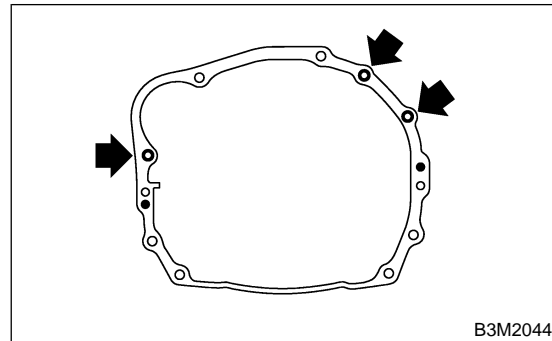

26) Install ST to torque converter clutch case. (AT model)

ST 498277200 STOPPER SET

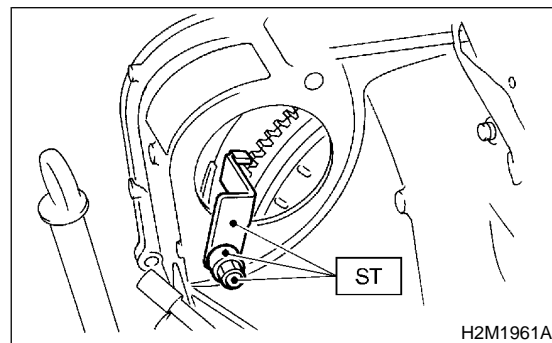

27) Remove engine from vehicle.

- (1) Slightly raise engine.
- (2) Raise transmission with garage jack.
- (3) Move engine horizontally until main shaft is withdrawn from clutch cover.
- (4) Slowly move engine away from engine compartment.

CAUTION:

Be careful not to damage adjacent parts or body panels with crank pulley, oil level gauge, etc.

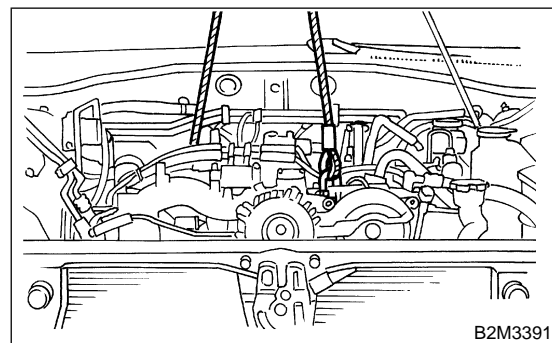

28) Remove front cushion rubbers.

ENGINE ASSEMBLY

Mechanical

B: INSTALLATION S103079A11

1) Install front cushion rubbers.

Tightening torque:

34±5 N·m (3.5±0.5 kgf-m, 25.3±3.6 ft-lb)

2) Install engine onto transmission.

(1) Position engine in engine compartment and align it with transmission.

CAUTION:

Be careful not to damage adjacent parts or body panels with crank pulley, oil level gauge, etc.

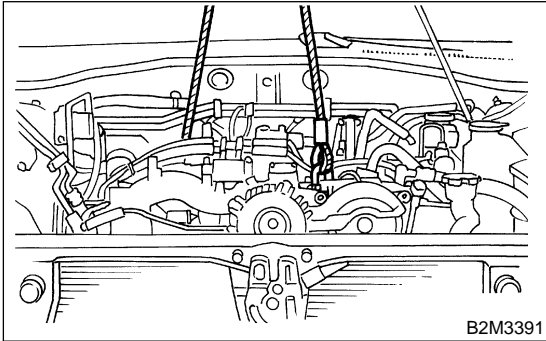

(2) Apply a small amount of grease to spline of main shaft. (MT model)

3) Tighten bolts which hold upper side of transmission to engine.

Tightening torque:

50 N·m (5.1 kgf-m, 36.9 ft-lb)

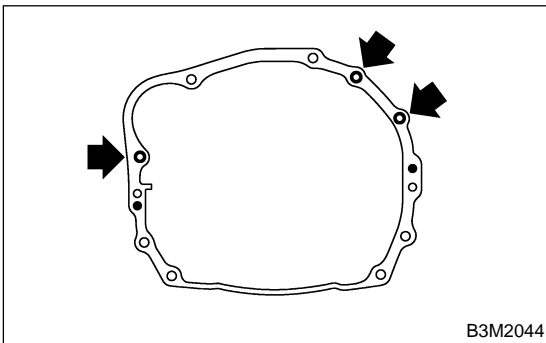

4) Remove lifting device and wire ropes.

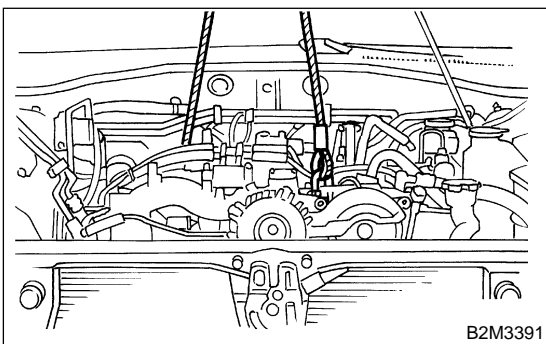

5) Remove garage jack.

6) Install pitching stopper.

Tightening torque:

T1: 49 N·m (5.0 kgf-m, 36.2 ft-lb)

T2: 57 N·m (5.8 kgf-m, 42 ft-lb)

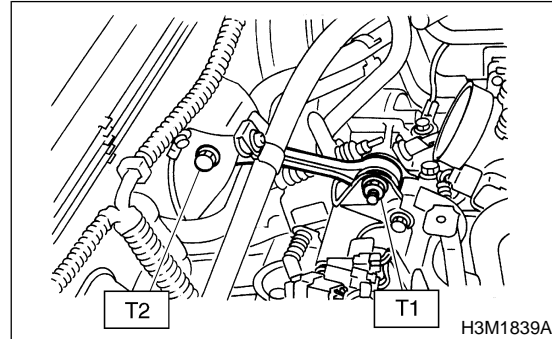

7) Remove ST from torque converter clutch case. (AT model)

NOTE:

Be careful not to drop the ST into the torque converter clutch case when removing ST.

ST 498277200 STOPPER SET

8) Install starter. <Ref. to SC(H4)-8 INSTALLATION, Starter.>

9) Install torque converter clutch onto drive plate. (AT model)

(1) Tighten bolts which hold torque converter clutch to drive plate.

(2) Tighten other bolts while rotating the engine by using ST.

CAUTION:

Be careful not to drop bolts into torque converter clutch housing.

ST 499977100 CRANK PULLEY WRENCH

Tightening torque:

25 N·m (2.5 kgf-m, 18.1 ft-lb)

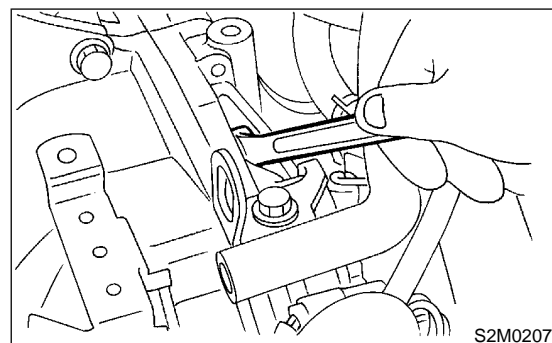

(3) Clog plug onto service hole.

10) Install power steering pump on bracket.

(1) Install power steering tank on bracket.

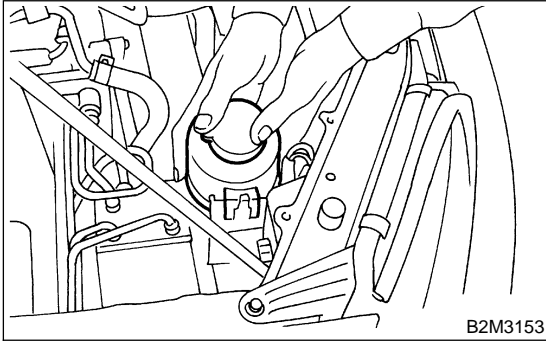

(2) Install power steering pump on bracket, and tighten bolts.

Tightening torque:

20.1 N·m (2.05 kgf-m, 14.8 ft-lb)

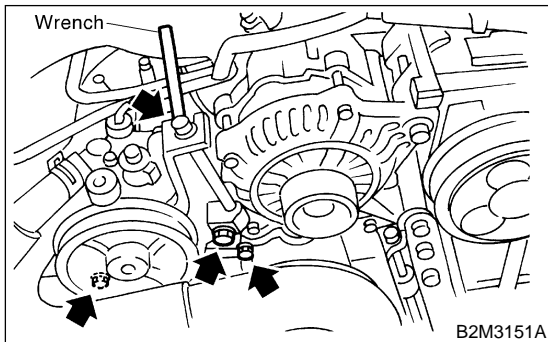

(3) Tighten bolt which installs power steering pump bracket, and install spark plug codes.

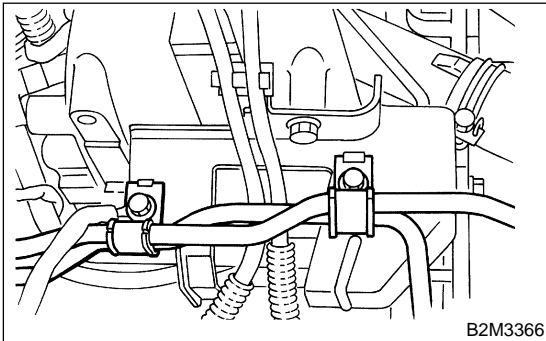

(4) Intake front side V-belt, and adjust it.

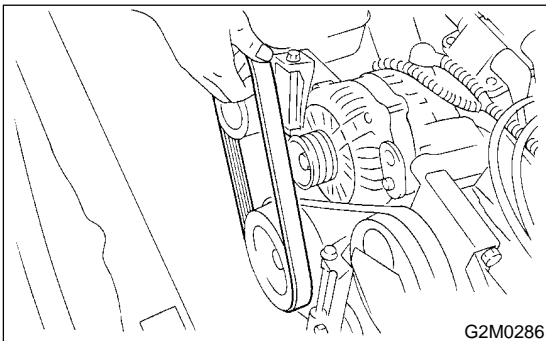

(5) Install resonator chamber.

Tightening torque:

33 N·m (3.4 kgf-m, 24.6 ft-lb)

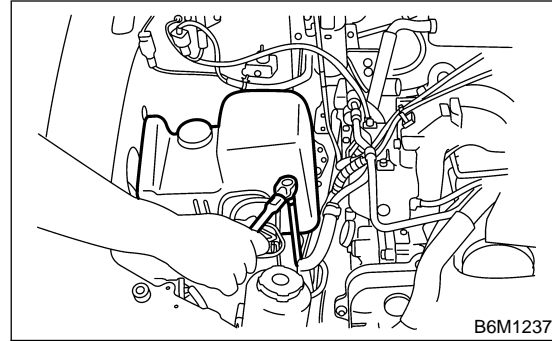

11) Tighten nuts which hold lower side of transmission to engine.

Tightening torque:

50 N·m (5.1 kgf-m, 36.9 ft-lb)

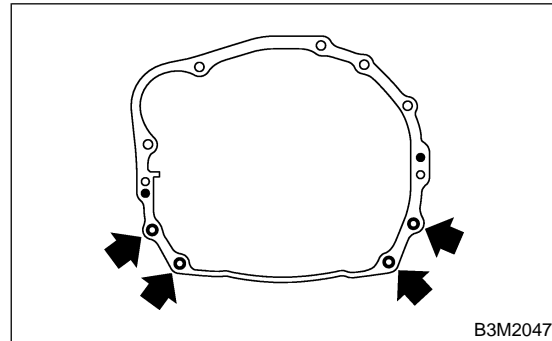

12) Tighten nuts which install front cushion rubber onto crossmember.

Tightening torque:

83 N·m (8.5 kgf-m, 61 ft-lb)

CAUTION:

Make sure the front cushion rubber mounting bolts (A) and locator (B) are securely installed.

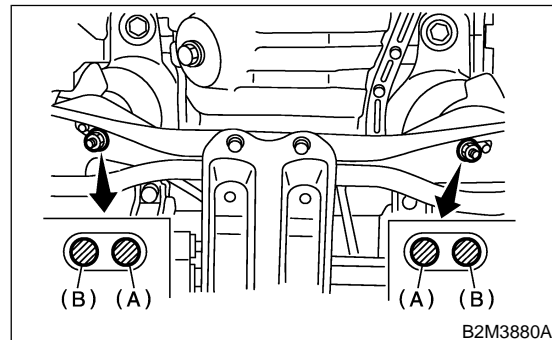

13) Install front and center exhaust pipe.
 <Ref. to EX(H4)-6 INSTALLATION, Front Exhaust Pipe.> and <Ref. to EX(H4)-8 INSTALLATION, Center Exhaust Pipe.>

14) Connect the following hoses.

ENGINE ASSEMBLY

Mechanical

- (1) Fuel delivery hose, return hose and evaporation hose
- (2) Heater inlet and outlet hoses
- (3) Brake booster vacuum hose
- 15) Connect the following connectors.
 - (1) Engine ground terminals

Tightening torque:

14 N·m (1.4 kgf-m, 10.1 ft-lb)

- (2) Engine harness connectors
- (3) Oxygen sensor connector (Except general model)
- (4) Alternator connector and terminal
- (5) A/C compressor connectors
- (6) Power steering pressure switch
- 16) Connect the following cables.
 - (1) Accelerator cable
 - (2) Cruise control cables (With cruise control)

CAUTION:

After connecting each cable, adjust them.

- 17) Install air cleaner case stay.

Tightening torque:

16 N·m (1.6 kgf-m, 11.6 ft-lb)

- 18) Install A/C pressure hoses.
<Ref. to AC-37 INSTALLATION, Flexible Hose.>

CAUTION:

Use new O-rings.

Tightening torque:

25 N·m (2.5 kgf-m, 18.1 ft-lb)

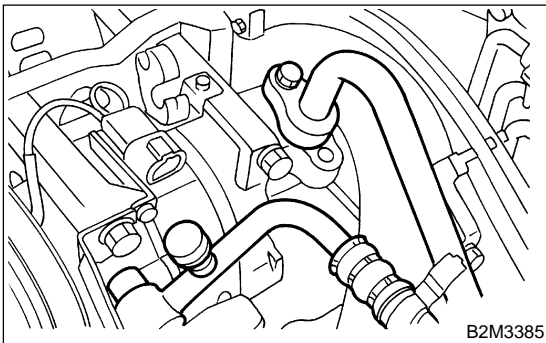

- 19) Install radiator to vehicle. <Ref. to CO(H4)-16 INSTALLATION, Radiator.>

- 20) Install V-belt cover.

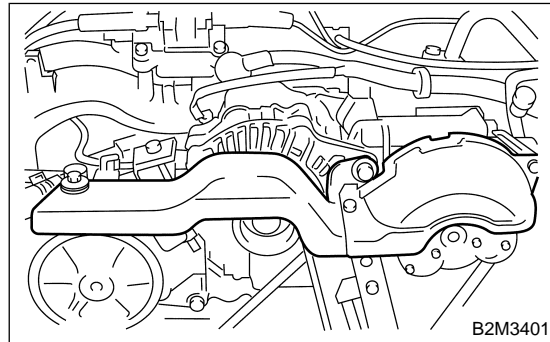

- 21) Install air intake duct and cleaner case.
<Ref. to IN(H4)-2 General Description.>

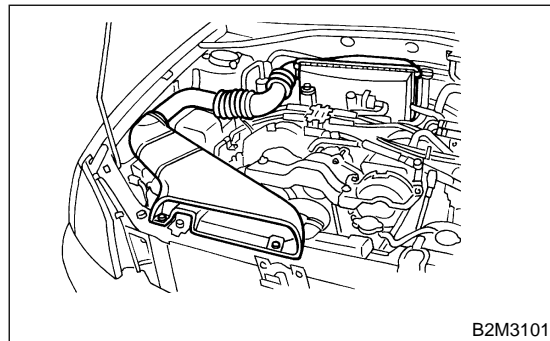

- 22) Install under cover.
- 23) Install battery in the vehicle, and connect cables.
- 24) Fill coolant.
<Ref. to CO(H4)-6 FILLING OF ENGINE COOLANT, REPLACEMENT, Engine Coolant.>
- 25) Check ATF level and correct if necessary. (AT model)
<Ref. to AT-9 Automatic Transmission Fluid.>
- 26) Charge A/C system with refrigerant.
<Ref. to AC-19 OPERATION, Refrigerant Charging Procedure.>
- 27) Remove front hood stay, and close front hood.
- 28) Take off the vehicle from lift arms.

C: INSPECTION S103079A10

- 1) Make sure pipes and hoses are installed correctly.
- 2) Make sure the engine coolant and ATF are at specified levels.