

15. Timing Belt Assembly S103099

A: REMOVAL S103099A18

1. TIMING BELT S103099A1802

- 1) Remove V-belt. <Ref. to ME(H4)-43 REMOVAL, V-belt.>
- 2) Remove crankshaft pulley. <Ref. to ME(H4)-44 REMOVAL, Crankshaft Pulley.>
- 3) Remove belt cover. <Ref. to ME(H4)-45 REMOVAL, Belt Cover.>
- 4) Remove timing belt guide. (MT vehicle only)

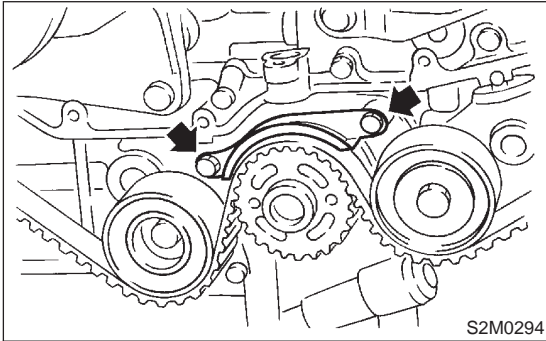

5) If alignment mark (a) and/or arrow mark (which indicates rotation direction) on timing belts in relation to the crank sprocket and cam sprockets.

- (1) Turn crankshaft using ST. Align mark (a) of sprocket to cylinder block notch (b) and ensure that right side cam sprocket mark (c), cam cap and cylinder head matching surface (d) and/or left side cam sprocket mark (e) and belt cover notch (f) are properly adjusted.

ST 499987500 CRANKSHAFT SOCKET

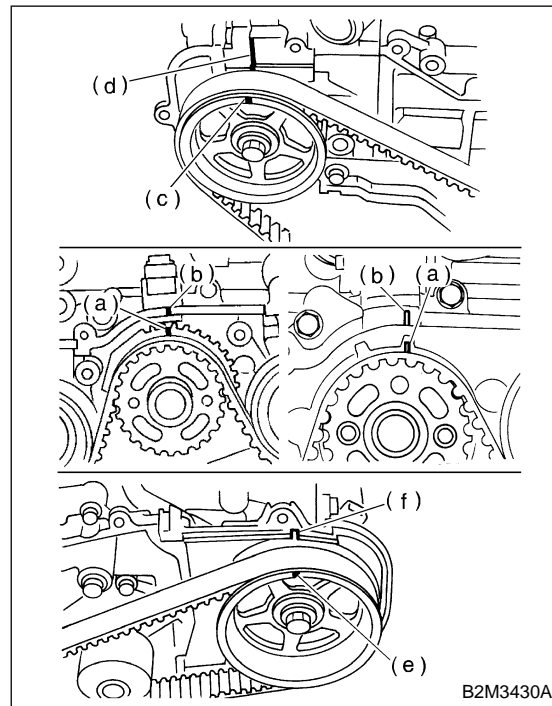
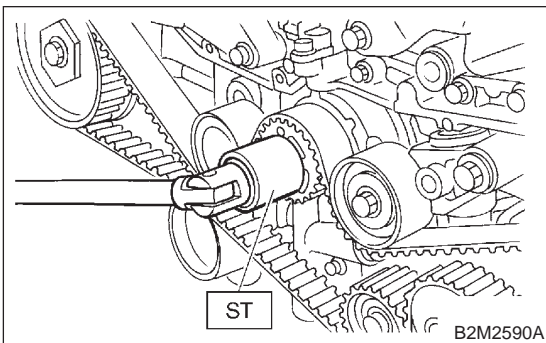

(2) Using white paint, put alignment and/or arrow marks on timing belts in relation to the crank sprocket and cam sprockets.

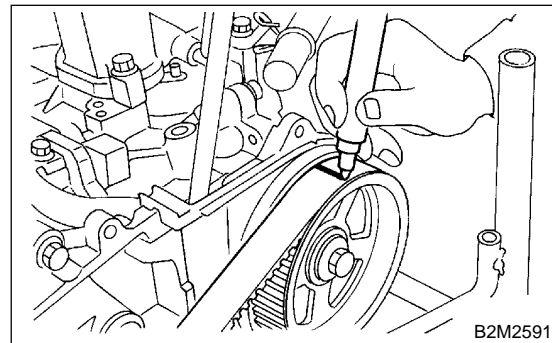

Specified data:

Z₁: 44 tooth length

Z₂: 40.5 tooth

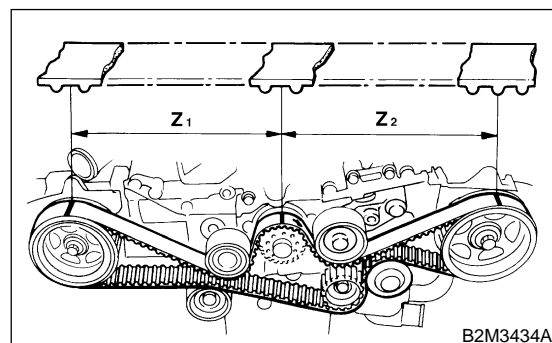

- 6) Remove belt idler (No. 2).
- 7) Remove belt idler No. 2.

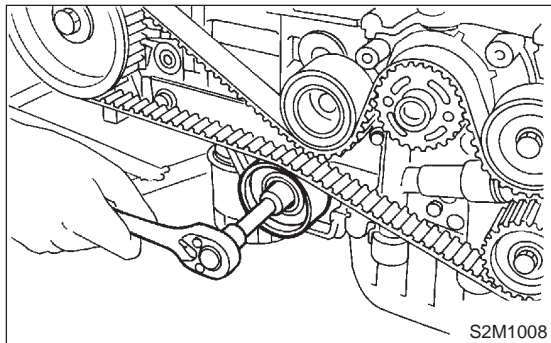

- 8) Remove timing belt.

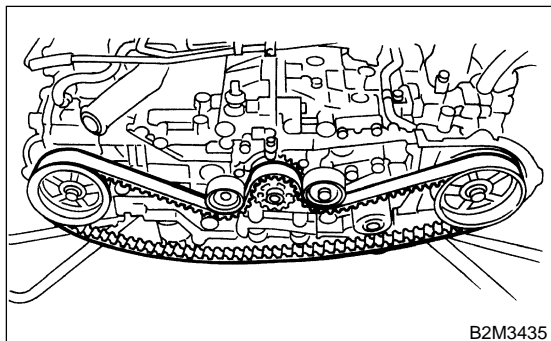

2. BELT IDLER AND AUTOMATIC BELT TENSION ADJUSTER ASSEMBLY S103099A1803

- 1) Remove belt idler (No. 1).

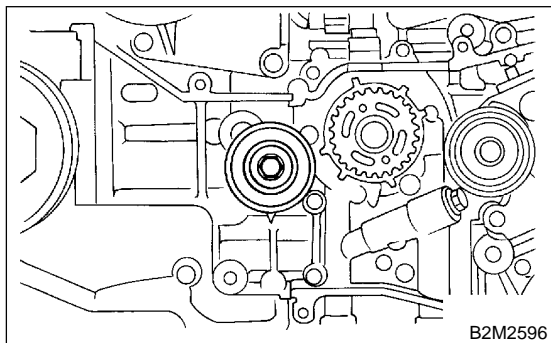

- 2) Remove automatic belt tension adjuster assembly.

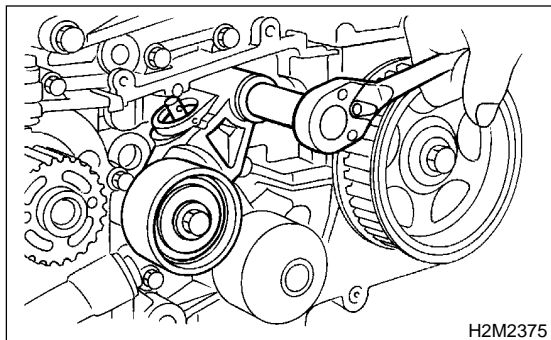

B: INSTALLATION S103099A11

1. AUTOMATIC BELT TENSION ADJUSTER ASSEMBLY AND BELT IDLER S103099A1102

- 1) Preparation for installation of automatic belt tension adjuster assembly;

CAUTION:

- Always use a vertical type pressing tool to move the adjuster rod down.
- Do not use a lateral type vise.
- Push adjuster rod vertically.
- Be sure to slowly move the adjuster rod down applying a pressure of 294 N (30 kg, 66 lb).
- Press-in the push adjuster rod gradually taking more than three minutes.
- Do not allow press pressure to exceed 9,807 N (1,000 kg, 2,205 lb).
- Press the adjuster rod as far as the end surface of the cylinder. Do not press the adjuster rod into the cylinder. Doing so may damage the cylinder.
- Do not release press pressure until stopper pin is completely inserted.

- (1) Attach the automatic belt tension adjuster assembly to the vertical pressing tool.
- (2) Slowly move the adjuster rod down with a pressure of 294 N (30 kg, 66 lb) until the adjuster rod is aligned with the stopper pin hole in the cylinder.

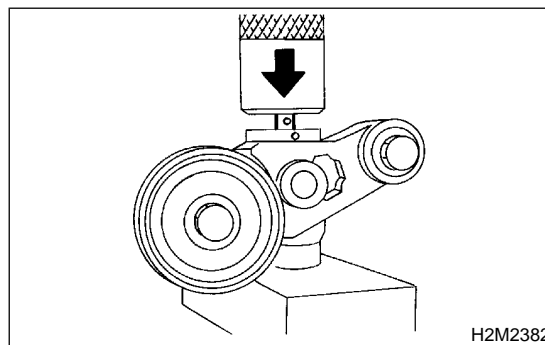

TIMING BELT ASSEMBLY

Mechanical

(3) With a 2 mm (0.08 in) dia. stopper pin or a 2 mm (0.08 in) (nominal) dia. hex bar wrench inserted into the stopper pin hole in the cylinder, secure the adjuster rod.

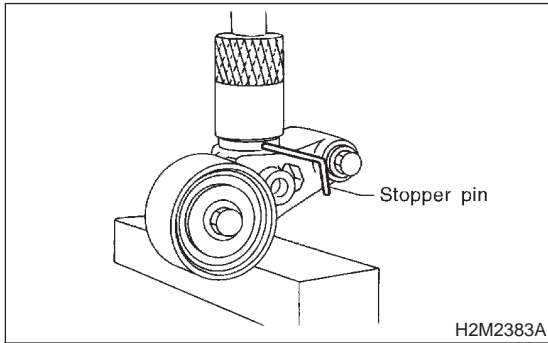

2) Install automatic belt tension adjuster assembly.

Tightening torque:

39 N·m (4.0 kgf·m, 28.9 ft·lb)

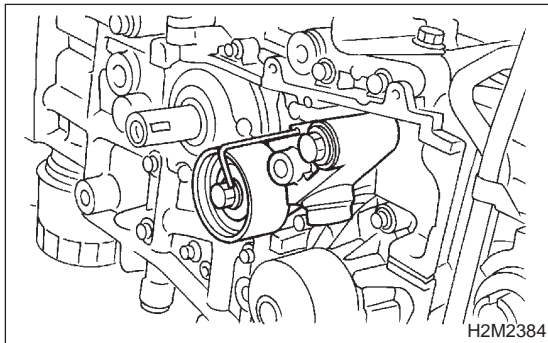

3) Install belt idler (No. 1).

Tightening torque:

39 N·m (4.0 kgf·m, 28.9 ft·lb)

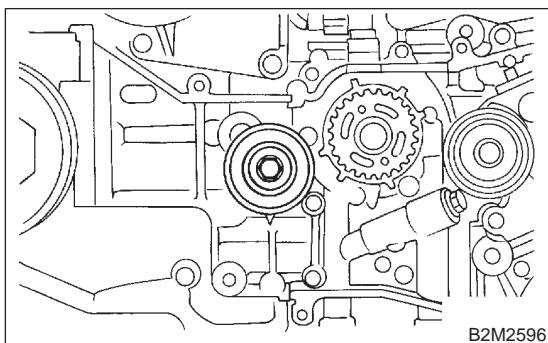

2. TIMING BELT S103099A1103

1) Preparation for installation of automatic belt tension adjuster assembly. <Ref. to ME(H4)-47 AUTOMATIC BELT TENSION ADJUSTER ASSEMBLY AND BELT IDLER, INSTALLATION, Timing Belt Assembly.>

2) Installation of timing belt

(1) Turn camshaft sprocket No. 2 using ST1, and turn camshaft sprocket No. 1 using ST2 so that their alignment marks come to top positions.

ST1 499207100 CAMSHAFT SPROCKET WRENCH

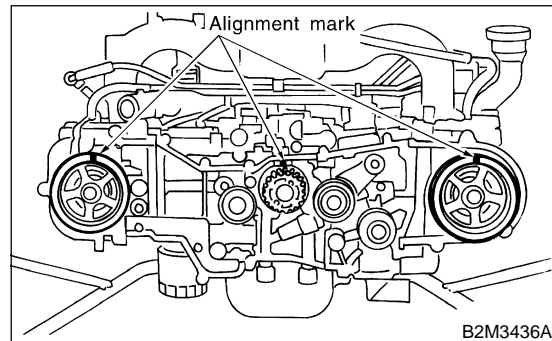

(2) While aligning alignment mark on timing belt with marks on sprockets, position timing belt properly.

CAUTION:

Ensure belt's rotating direction is correct.

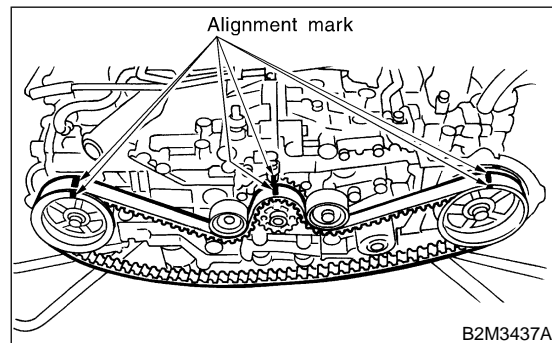

3) Install belt idler No. 2.

Tightening torque:

39 N·m (4.0 kgf·m, 28.9 ft·lb)

4) Install belt idler (No. 2).

Tightening torque:

39 N·m (4.0 kgf·m, 28.9 ft·lb)

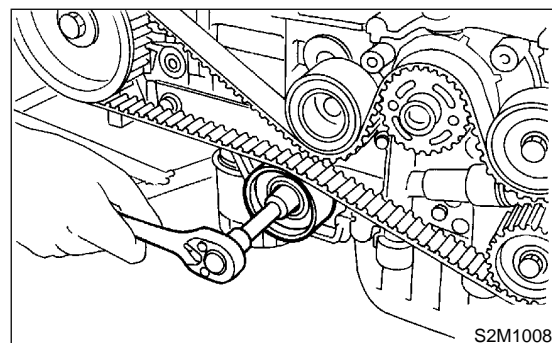

5) After ensuring that the marks on timing belt and camshaft sprockets are aligned, remove stopper pin from belt tensioner adjuster.

CAUTION:

After properly installing timing belt, remove rocker cover and ensure that the valve lash adjuster contains no air.

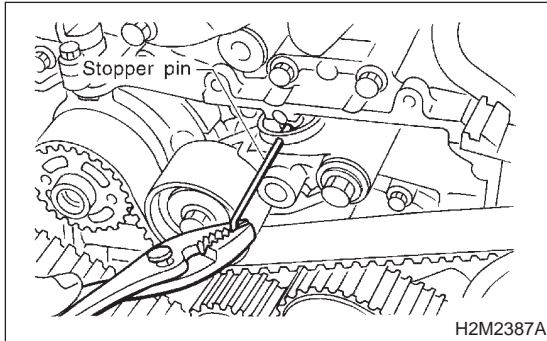

6) Install timing belt guide. (MT vehicles only)
 (1) Temporarily tighten remaining bolts.

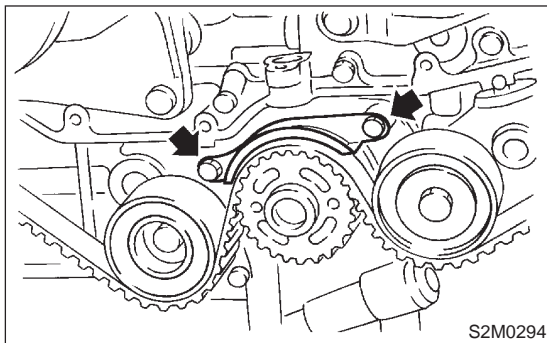

(2) Check and adjust clearance between timing belt and timing belt guide by using thickness gauge.

Clearance:

1.0±0.5 mm (0.039±0.020 in)

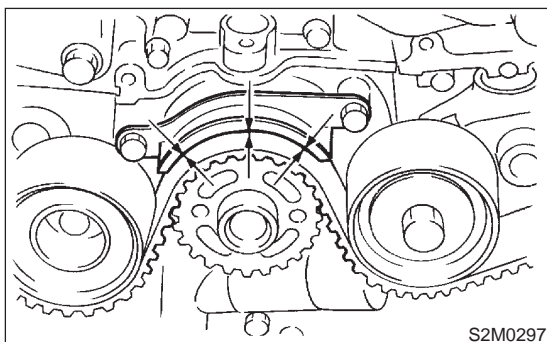

(3) Tighten remaining bolts.

Tightening torque:

9.8 N·m (1.0 kgf-m, 7.2 ft-lb)

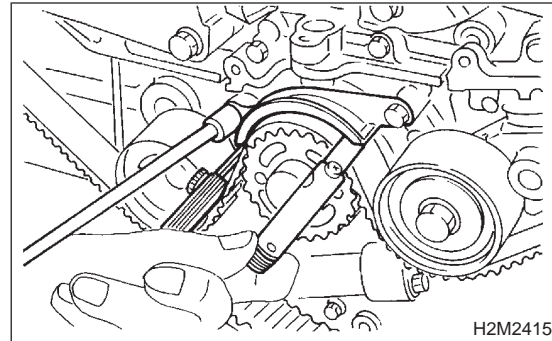

7) Install belt cover. <Ref. to ME(H4)-45 INSTALLATION, Belt Cover.>

8) Install crankshaft pulley. <Ref. to ME(H4)-44 REMOVAL, Crankshaft Pulley.>

9) Install V-belt. <Ref. to ME(H4)-43 INSTALLATION, V-belt.>

C: INSPECTION

S103099A10

1. TIMING BELT

S103099A1001

1) Check timing belt teeth for breaks, cracks, and wear. If any fault is found, replace belt.

2) Check the condition of back side of belt; if any crack is found, replace belt.

CAUTION:

- Be careful not to let oil, grease or coolant contact the belt. Remove quickly and thoroughly if this happens.
- Do not bend the belt sharply.

Bending radius: h

60 mm (2.36 in) or more

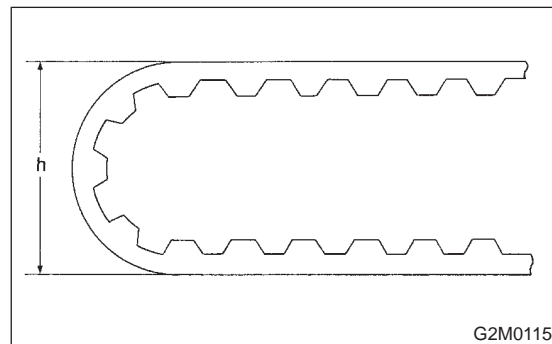

2. AUTOMATIC BELT TENSION ADJUSTER

S103099A1002

1) Visually check oil seals for leaks, and rod ends for abnormal wear or scratches. If necessary, replace faulty parts.

TIMING BELT ASSEMBLY

Mechanical

CAUTION:

Slight traces of oil at rod's oil seal does not indicate a problem.

2) Check that the adjuster rod does not move when a pressure of 294 N (30 kg, 66 lb) is applied to it. This is to check adjuster rod stiffness.

3) If the adjuster rod is not stiff and moves freely when applying 294 N (30 kg, 66 lb), check it using the following procedures:

(1) Slowly press the adjuster rod down to the end surface of the cylinder. Repeat this motion 2 or 3 times.

(2) With the adjuster rod moved all the way up, apply a pressure of 294 N (30 kg, 66 lb) to it. Check adjuster rod stiffness.

(3) If the adjuster rod is not stiff and moves down, replace the automatic belt tension adjuster assembly with a new one.

CAUTION:

- Always use a vertical type pressing tool to move the adjuster rod down.
- Do not use a lateral type vise.
- Push adjuster rod vertically.
- Press-in the push adjuster rod gradually taking more than three minutes.
- Do not allow press pressure to exceed 9,807 N (1,000 kg, 2,205 lb).
- Press the adjuster rod as far as the end surface of the cylinder. Do not press the adjuster rod into the cylinder. Doing so may damage the cylinder.

4) Measure the extension of rod beyond the body. If it is not within specifications, replace with a new one.

Rod extension: H

$5.7 \pm 0.5 \text{ mm}$ ($0.224 \pm 0.020 \text{ in}$)

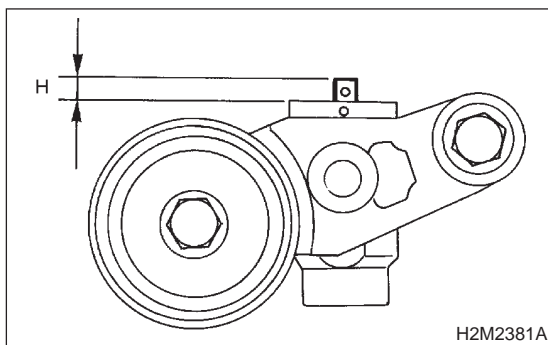

3. BELT TENSION PULLEY S103099A1003

1) Check mating surfaces of timing belt and contact point of adjuster rod for abnormal wear or scratches. Replace automatic belt tension adjuster assembly if faulty.

2) Check tension pulley for smooth rotation. Replace if noise or excessive play is noted.

3) Check tension pulley for grease leakage.

4. BELT IDLER S103099A1004

1) Check belt idler for smooth rotation. Replace if noise or excessive play is noted.

2) Check belt outer contacting surfaces of idler pulley for abnormal wear and scratches.

3) Check belt idler for grease leakage.

ME(H4)-50